

---

**INPUT AND OUTPUT POWER ADJUSTMENTS**  
**PRIMARY FREQUENCY CONVERTER**  
**LMX-1 AND L3 CARRIER**  
**ANALOG MULTIPLEX TERMINAL EQUIPMENT**

---

This section explains test procedures for primary frequency converter J68828B (Fig. 1) and J68828AB. A primary frequency converter (Fig. 2 and Fig. 3) receives 4-kHz and 128-kHz input signals from a 4-kHz frequency supply. A harmonic generator provides outputs at 216, 516, 520, and 556 kHz.

This section is reissued to add an introduction, to correct errors, and to expand and improve the test procedure. Due to the general revision, arrows are not used to indicate changes. **Equipment Test Lists are not affected.**

---

| CHART   | PAGE |
|---|------|
| 1—Measurement of 4-kHz and 128-kHz Input Signals . . . . .              | 1    |
| 2—Measurement of 216-kHz, 520-kHz, and 556-kHz Output Signals . . . . . | 6    |

---

**CHART 1**  
**MEASUREMENT OF 4-KHZ AND 128-KHZ INPUT SIGNALS**

---

**APPARATUS:**

The tests in this chart require suitable transmission test equipment. Refer to Section 356-010-500 and select from available equipment receiving units having the following capabilities:

**Receiving Test Equipment** (RTE) capable of detecting, from 135-ohm circuits, signals between 4 and 128 kHz at powers between -1.0 and +2.0 dBm

**3P20B Cords**, as required

**135-ohm Balanced Attenuator** (the attenuator contained in the 30A transmission measuring set is suitable for these tests).

**NOTICE**

Not for use or disclosure outside the  
Bell System except under written agreement

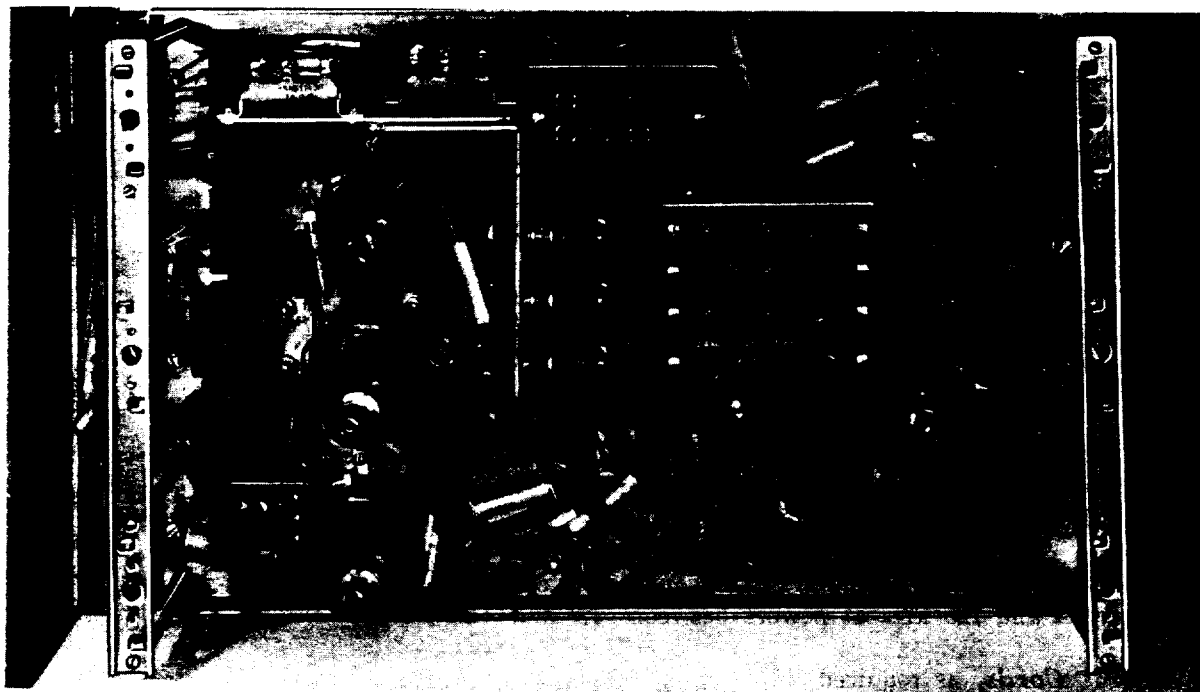
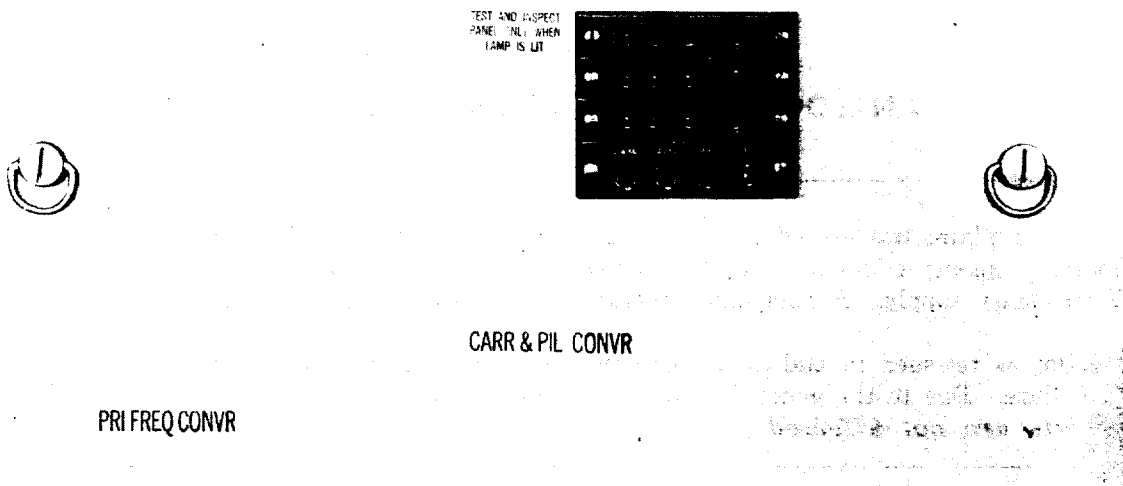

Fig. 1—Primary Frequency Converter J68828B

## CHART 1 (Contd)

| STEP | PROCEDURE   |
|------|---|
|      | <b>Caution:</b> <i>The number of transfers of the carrier supply should be kept to a minimum to avoid bits on data and carrier telegraph service.</i>   |
| 1    | Lock out of service the primary frequency converter under test per Section 356-150-300.   |
|      | <b>Caution:</b> <i>Do not proceed with this test until the green A lamp associated with the primary frequency converter panel under test is lighted.</i>  |
| 2    | Condition RTE to make a 135-ohm terminated measurement of 4 kHz at -1.0 dBm.  |
| 3    | Measure power of 4-kHz signal at 4 KC PAD OUT jack [patches (1) and (2), Fig. 2 or 3].  |
|      | <b>Requirement:</b> -1.0 dBm $\pm$ 2.0 dB when converter is fed by primary frequency supply PFS-1<br><b>or</b><br>-1.0 dBm $\pm$ 1.0 dB when converter is fed by primary frequency supply PFS-2 |
| 4    | Proceed to Step 8 if the requirement <i>is</i> met. Otherwise, perform Steps 5 through 7, as required.  |
| 5    | Test associated primary frequency supply per Section 356-151-504 for PFS-1, Section 354-102-506 for PFS-2A, or Section 354-105-506 for PFS-2B.  |
| 6    | Repeat Step 3.  |
| 7    | Restrap the 4 KC PAD per SD-59552 or SD-59733 for an RTE indication of -1.0 dBm, if the requirement of Step 3 <b>still cannot</b> be met.   |
| 8    | Remove patch (2), Fig. 2 or 3.  |
| 9    | Condition RTE to make a 135-ohm terminated measurement of 128 kHz at +2.0 dBm.  |
| 10   | Measure power of 128-kHz signal at 128 KC PAD OUT jack [patch (3), Fig. 2 or 3].  |
|      | <b>Requirement:</b> +2.0 dBm $\pm$ 1.5 dB when converter is fed by PFS-1<br><b>or</b><br>+2.0 dBm $\pm$ 1.0 dB when converter is fed by PFS-2   |
| 11   | Restrap the 128 KC PAD per SD-59552 or SD-59733 for RTE indication of +2.0 dBm, if the requirement of Step 10 is <b>not</b> met.  |
| 12   | Remove all patch cords.   |
| 13   | Restore panel to service per Section 356-150-300, if further testing of this panel per Chart 2 is <b>not</b> required.  |

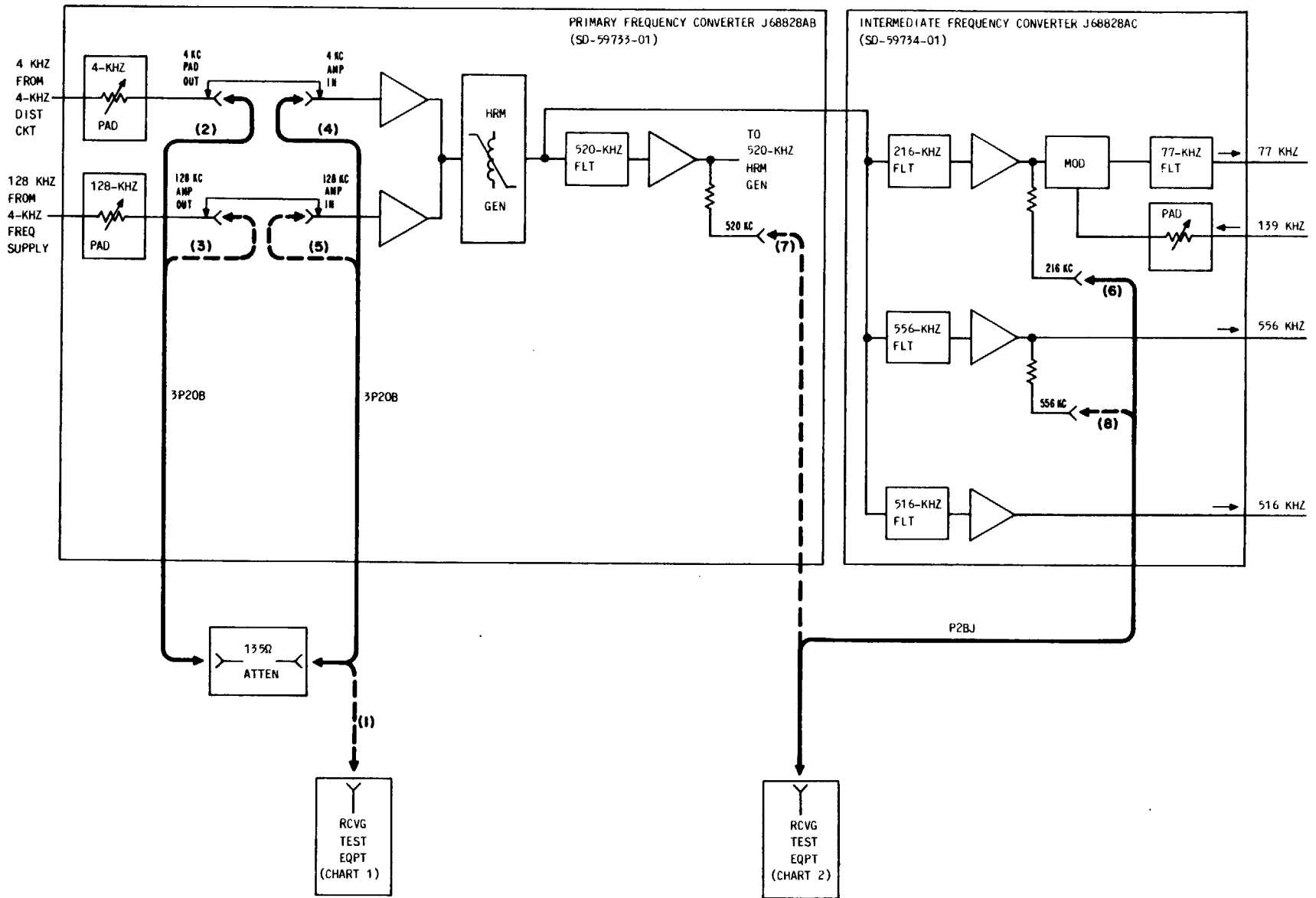

Fig. 2—Input and Output Power Measurements for Primary Frequency Converter J68828AB

L3 CARRIER SUPPLY BAY

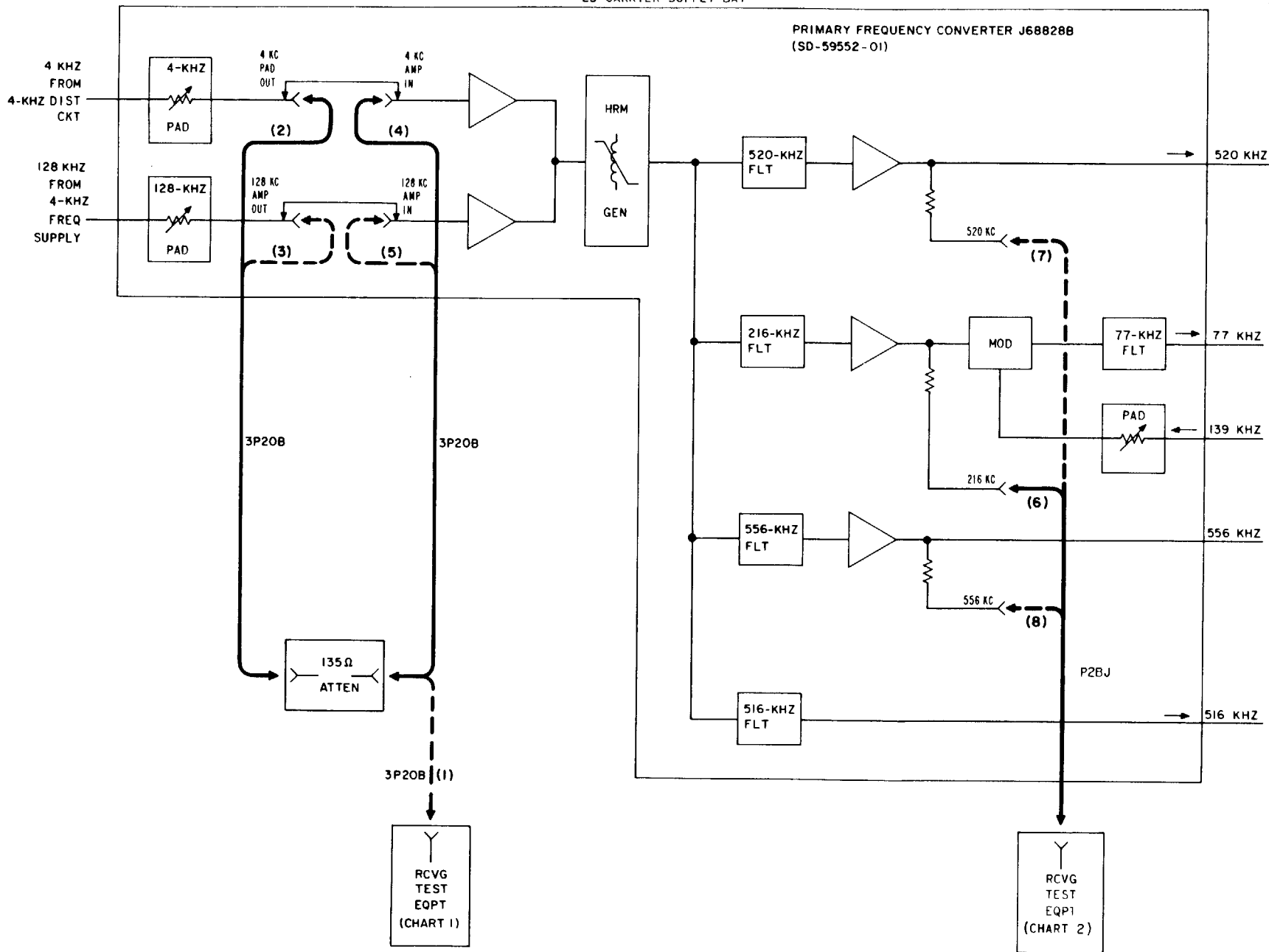

Fig. 3—Input and Output Power Measurements for Primary Frequency Converter J68828B

## CHART 2

## MEASUREMENT OF 216-KHZ, 520-KHZ, AND 556-KHZ OUTPUT SIGNALS

## APPARATUS:

The tests in this chart require suitable transmission test equipment. Refer to Section 356-010-500 and select from available equipment receiving units having the following capabilities:

**Receiving Test Equipment** (RTE) capable of detecting, from 75-ohm circuits, signals between 216 and 556 kHz at powers between -17.5 and -30.5 dBm

**Nonmetallic Screwdriver**

**165C Dummy Plugs**, as required

**Resistor KS-13491, List 3**, 51,000 ohms with clip on one end

**P2BJ Cord**

**W2ED Cord** (coaxial jack on one end and test clip on the other end)

**3P20B Cords**, as required

**135-ohm Balanced Attenuator** (the attenuator contained in the 30A transmission measuring set is suitable for these tests).

## STEP

## PROCEDURE

**Caution:** *The number of transfers of the carrier supply should be kept to a minimum to avoid hits on data and carrier telegraph service.*

- 1 Lock out of service the primary frequency converter under test per Section 356-150-300.
- Caution:** *Do not proceed with this test until the green A lamp associated with the primary frequency converter panel under test is lighted.*
- 2 Condition RTE to make 75-ohm terminated measurements.
  - 3 Connect a 135-ohm balanced attenuator set at 0.0 dB between the 4 KC PAD OUT and 4 KC AMP IN jacks [patches (2) and (4), Fig. 2 or 3].
  - 4 Measure and record the 216-kHz power at the 216 KC test jack [patch (6), Fig. 2 or 3].
  - 5 Repeat the measurement and record the power with the attenuator set at 1.0 dB.
  - 6 Repeat the measurement and record the power with the attenuator set at 2.0 dB.

---

**CHART 2 (Contd)**

---

| STEP | PROCEDURE  |
|------|--|
|      | <b>Requirement:</b> The lowest and highest power values for the frequency under test shall not differ more than 4.0 dB with the three attenuator settings. |
| 7    | Set the attenuator to 0.0 dB.  |
| 8    | Repeat Steps 4 through 7 for the 520-kHz signal at the 520 KC test jack [patch (7), Fig. 2 or 3].  |
| 9    | Repeat Steps 4 through 7 for the 556-kHz signal at the 556 KC test jack [patch (8), Fig. 2 or 3].  |
| 10   | Proceed to Step 13 if the requirement in Step 6 is met at all three frequencies. Otherwise, proceed to Step 11.  |
| 11   | Complete the procedure in Chart 1.   |
| 12   | Repeat Steps 1 through 10, as required, in this chart.   |
| 13   | Remove the attenuator from the 4 KC jacks.   |
| 14   | Connect the attenuator, set at 0.0 dB, between the 128 KC PAD OUT and 128 KC AMP IN jacks [patches (3) and (5), Fig. 2 or 3].                              |
| 15   | Repeat Steps 4 through 9.  |
| 16   | Remove the attenuator from the 128 KC jacks.   |
| 17   | Measure and record the power of the 216-kHz, 520-kHz, and 556-kHz signals at the test jacks [patches (6), (7), and (8), Fig. 2 or 3].                      |
|      | <b>Requirement:</b> Minimum power is -30.5 dBm at 216 kHz, -17.5 dBm at 520 kHz, and -22.5 dBm at 556 kHz.   |
| 18   | Proceed to Step 32 if the requirement is met. Otherwise, proceed to Step 19.   |
| 19   | Remove the cover from the primary frequency converter panel.   |
| 20   | Insert two 165C dummy plugs into the 4 KC AMP IN jack.   |
| 21   | Connect the 135-ohm attenuator, set for 20.0 dB, between the 128 KC PAD OUT and 128 KC AMP IN jacks [patches (3) and (5), Fig. 2 or 3].                    |
| 22   | Condition the RTE to make a 75-ohm terminated measurement at 128 kHz.  |
| 23   | Connect a 51,000-ohm resistor, using a W2ED cord, between output transformer T2 and the RTE [patch (9), Fig. 4].   |

## CHART 2 (Contd)

| STEP | PROCEDURE   |
|------|---|
| 24   | Adjust capacitor C1 in the primary frequency converter for a maximum power indication on the RTE.<br><br><i>Note:</i> Maximum power should be approximately -20 dBm.  |
| 25   | Remove the 165C dummy plugs from the 4 KC AMP IN jack.  |
| 26   | Remove the attenuator from the 128 KC jacks.  |
| 27   | Repeat the measurements in Step 17 while adjusting capacitor C32 for maximum output power at each of the three frequencies.<br><br><i>Note:</i> Restrapping of capacitors C30 and C31 may be necessary. The signal power at each of the three frequencies should be the highest obtainable. Adjusting capacitor C32 may increase the output at one frequency while slightly decreasing the output at another frequency. Adjust the capacitor so that the requirement in Step 17 is met.   |
| 28   | Repeat Steps 2 through 17.  |
| 29   | Proceed to Step 32 if the requirement of Step 17 is met. Otherwise, proceed to Step 30.   |
| 30   | Repeat the measurements in Step 17 while adjusting inductor L13 and capacitor C32 for maximum output power at the three frequencies.<br><br><i>Note:</i> See <i>Note</i> in Step 27. Inductor L13 is accessible at the front of primary frequency converter panel J68828AB (SD-59733). Inductor L13 is mounted on the applique unit and is not accessible at the front of primary frequency converter panel J68828B (SD-59552). In back-to-back bay arrangements, the rear panel must be dismantled and supported on maintenance brackets per ED-63343 in order to gain access to inductor L13. |
| 31   | Repeat Steps 2 through 18, as required.   |
| 32   | Remove all patches and plugs.   |
| 33   | Replace the cover on the primary frequency converter panel.   |
| 34   | Restore the panel to service per Section 356-150-300.   |



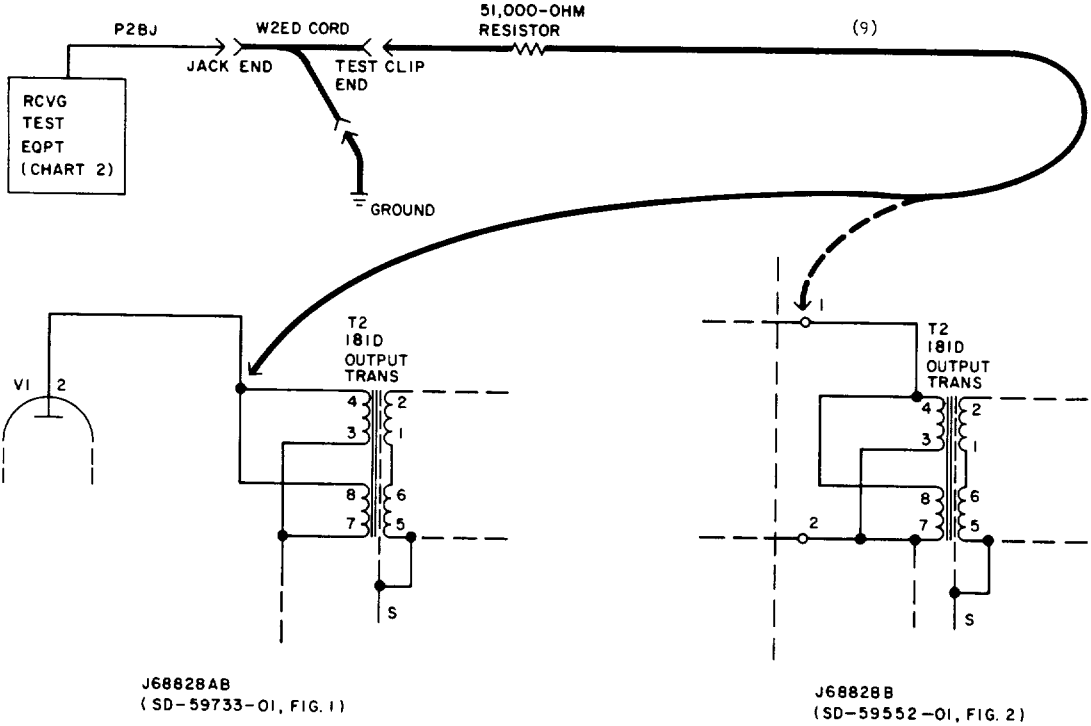

Fig. 4—Test Connections for Measurements at Output Transformer