L MULTIPLEX TERMINALS
LMX-1
INTERMEDIATE FREQUENCY CONVERTER CIRCUIT
516-KHZ OUTPUT TESTS

This procedure tests the 516-kHz amplifier and distributing circuits (Fig. 1) which are used to produce 1211, 2064, and 3096-kHz signals for the generation of L3 carrier pilots. This section is reissued to clarify the test procedure and to correct typographical errors. Arrows normally used to indicate changes have been omitted. *Equipment Test Lists are not affected.*

APPARATUS

Receiving Test Equipment (RTE) (Section 356-010-500) having the following characteristics:

Frequency: 516 kHz

Input Impedance: 75 ohms

Input Power: -37.0 to -10.5 dBm

P2BJ Cord

W2ED Cord

STEP

PROCEDURE

- 1 Condition RTE to make a 75-ohm terminated measurement of 516 kHz at -37 dBm.
- 2 Measure the power at the 516 KC TST jack [patch (1), Fig. 2].
Requirement: -37.0 \pm 2.0 dBm
- 3 If the requirement of Step 2 is *not* met, adjust GAIN control (R4) (Fig. 2).
- 4 If the requirement of Step 2 *cannot* be met by adjustment, test the primary frequency converter circuit in accordance with Section 356-165-501.

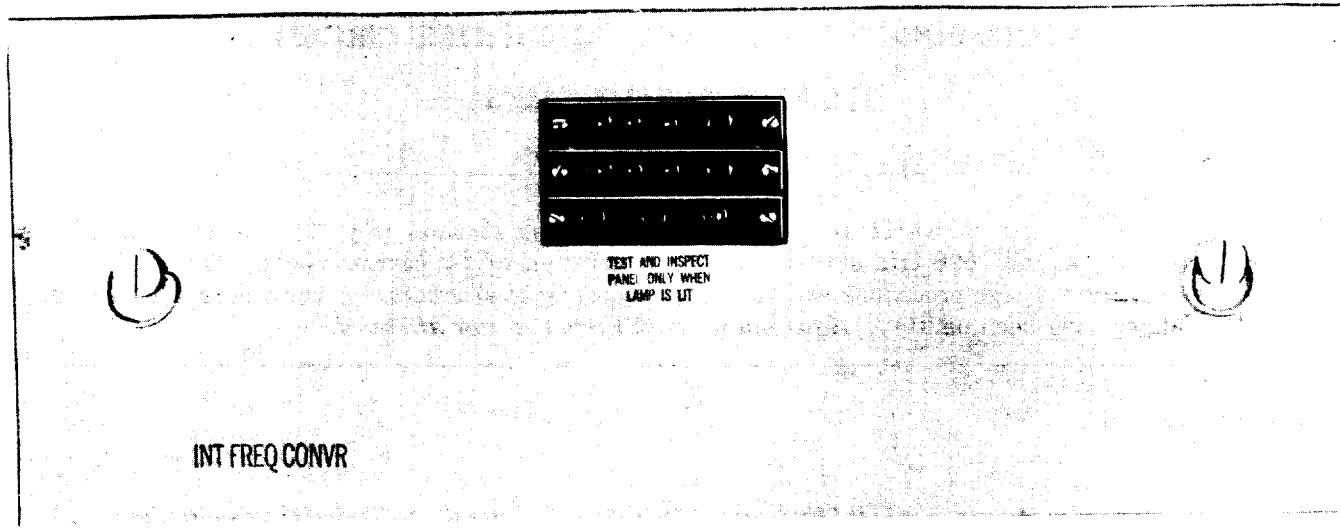

(COVER ON)

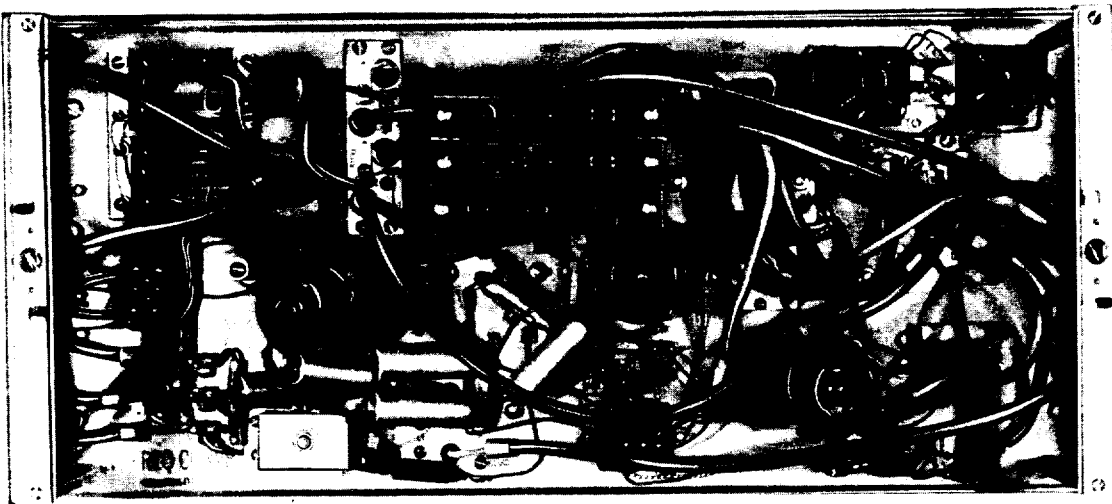

(COVER REMOVED)

Fig. 1—Intermediate Frequency Converter Circuit With and Without Cover

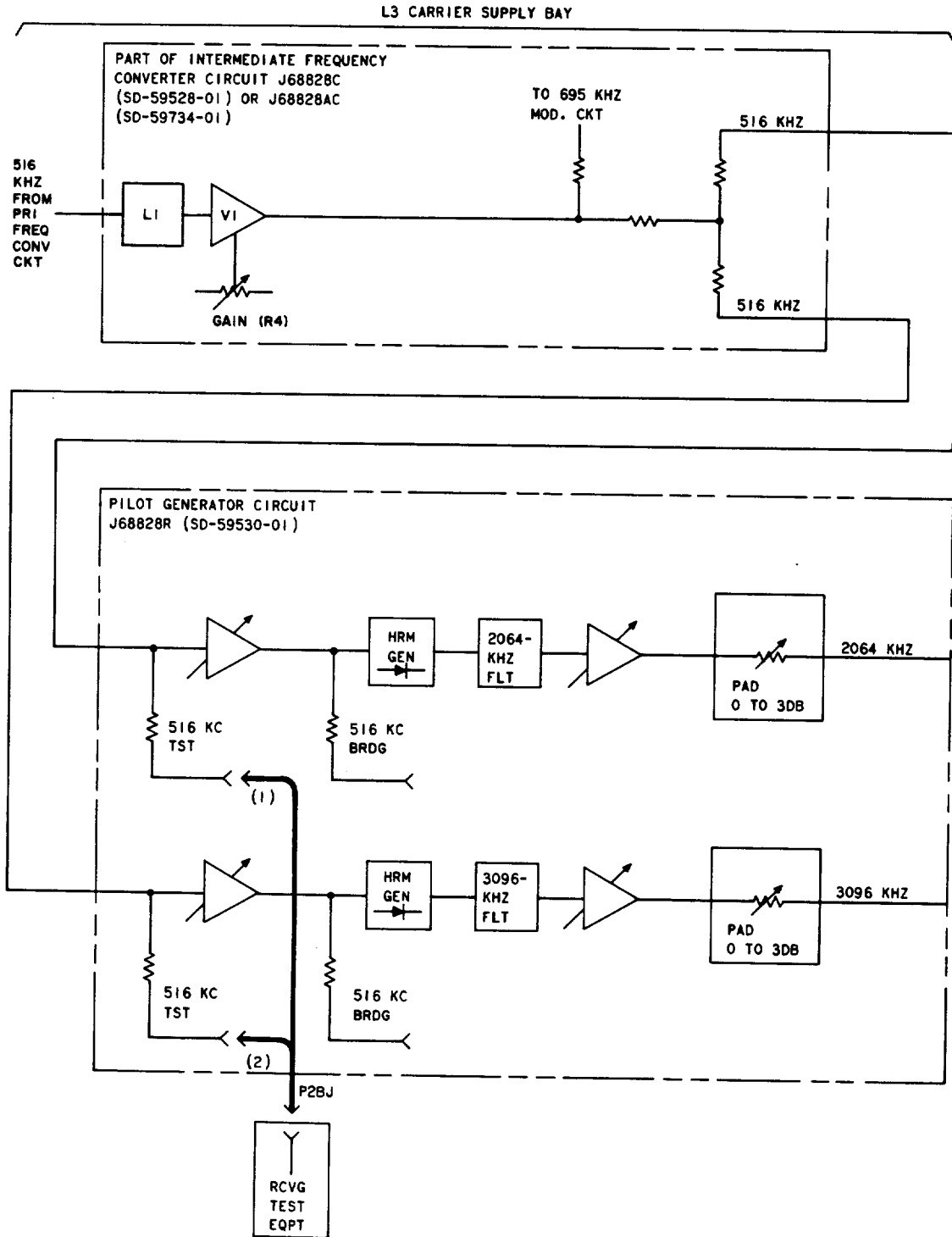

Fig. 2—Intermediate Frequency Converter Circuit—Measurement of the 516-kHz Output

STEP

PROCEDURE

- 5 If the requirement of Step 2 *still cannot* be met, take the intermediate frequency converter under test *out of service* (Section 356-150-300).

Caution 1: Do not proceed with this test until the green lamp associated with the intermediate frequency converter under test is lighted.

Caution 2: The number of transfers of the carrier supply should be kept to a minimum to avoid hits on data and carrier telegraph service.

- 6 Remove patch (1), Fig. 2.
- 7 Condition RTE to make a 75-ohm terminated measurement of 516 kHz at -10.5 dBm.
- 8 Connect a W2ED cord to the RTE [patch (1), Fig. 3].
- 9 Depending on the type of intermediate frequency converter under test, connect the W2ED cord to inductor L1 as shown in Fig. 3.
- 10 Measure the power of the 516-kHz signal.

Requirement: -10.5 dBm (minimum)

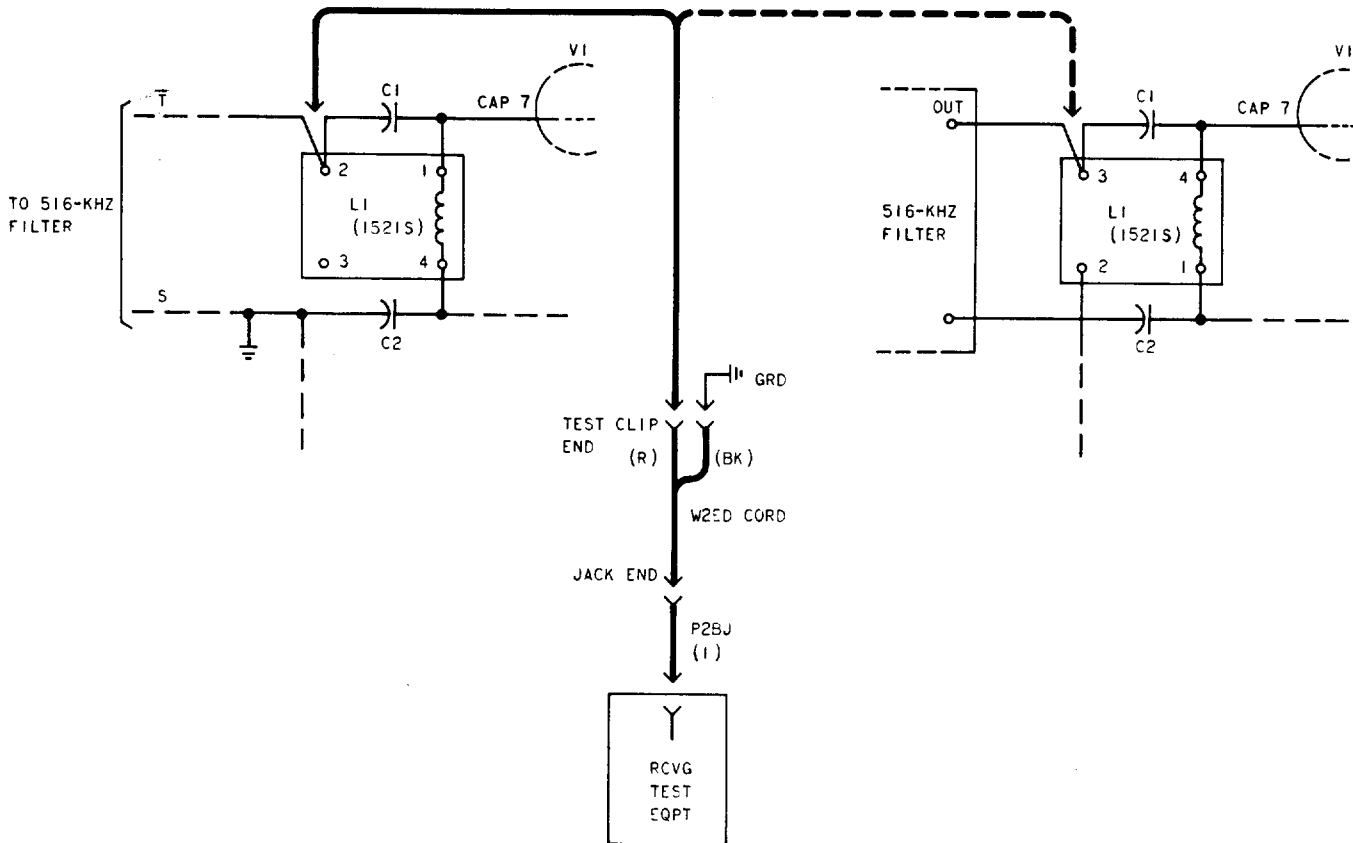

Fig. 3—Test Patch Using W2ED Cord

STEP	PROCEDURE
11	If the requirement of Step 10 is met, replace V1 in the intermediate frequency converter under test and repeat Steps 1 and 2.
12	If the requirement of Step 10 is <i>not</i> met, investigate trouble in 516-kHz filter circuits.
13	Remove the W2ED cord and patch (1), Fig. 3.
14	Condition RTE to make a 75-ohm terminated measurement of 516 kHz at -37 dBm.
15	Measure the power at the 516 KC TST jack [patch (2), Fig. 2]. <i>Requirement:</i> -37.0 ± 2.0 dBm
16	Restore the intermediate frequency converter panel under test to service (Section 356-150-300).
17	Remove patch (2), Fig. 2.
