L MULTIPLEX TERMINALS
LMX-1, MMX-1
CARRIER AND PILOT SUPPLY
520-KHZ HARMONIC GENERATOR CIRCUIT
520-KHZ OUTPUT TEST

This section provides procedures for in-service measurement of the 520-kHz harmonic generator output (Fig. 1).

This section is reissued to add a maintenance note to Step 4. *Equipment Test Lists are not affected.*

APPARATUS

J64070B (70B) or J64074A (74A) Power Meter

P2BJ Cords, as required

75-ohm Attenuator, adjustable in 1-dB steps



STEP

PROCEDURE

- | | |
|---|--|
| 1 | Prepare the power meter (PWR MTR) for a 75-ohm measurement at a power of +0.5 dBm. |
| 2 | Set the attenuator to 10 dB. |
| 3 | Make patches (1) and (2), Fig. 2. |
| 4 | Reduce the attenuator to 5.0 dB, and read the PWR MTR indication. |

Requirement: Not less than +0.5 dBm

Note: If any jitter of the PWR MTR indication is observed, check capacitors C1 and C32 for proper adjustment at the correct resonance point as specified in Section 356-165-501, Chart 2.

STEP	PROCEDURE
	<p data-bbox="751 576 857 629">TEST AND INSPECT PANEL ONLY WHEN LAMP IS LIT</p>  

520KC HRM GEN

A. WITH COVER

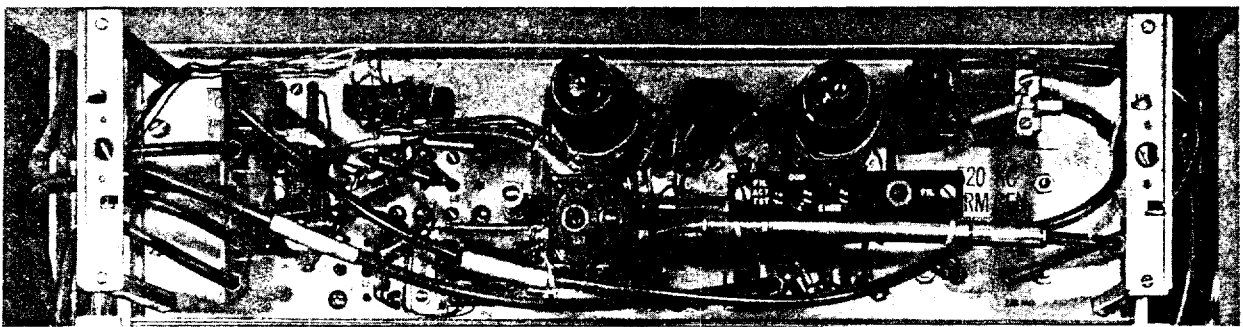

B. WITH COVER REMOVED

Fig. 1—520-kHz Harmonic Generator With and Without Cover

- 5 If the requirement is met, proceed to Step 6. If it is not met, perform tests in accordance with Sections 356-150-501 (Electron Tube Tests) and 356-165-501 (Primary Frequency Converter, Input and Output Measurements). Repeat Steps 1 through 4.
- 6 Remove patches (1) and (2), Fig. 2.

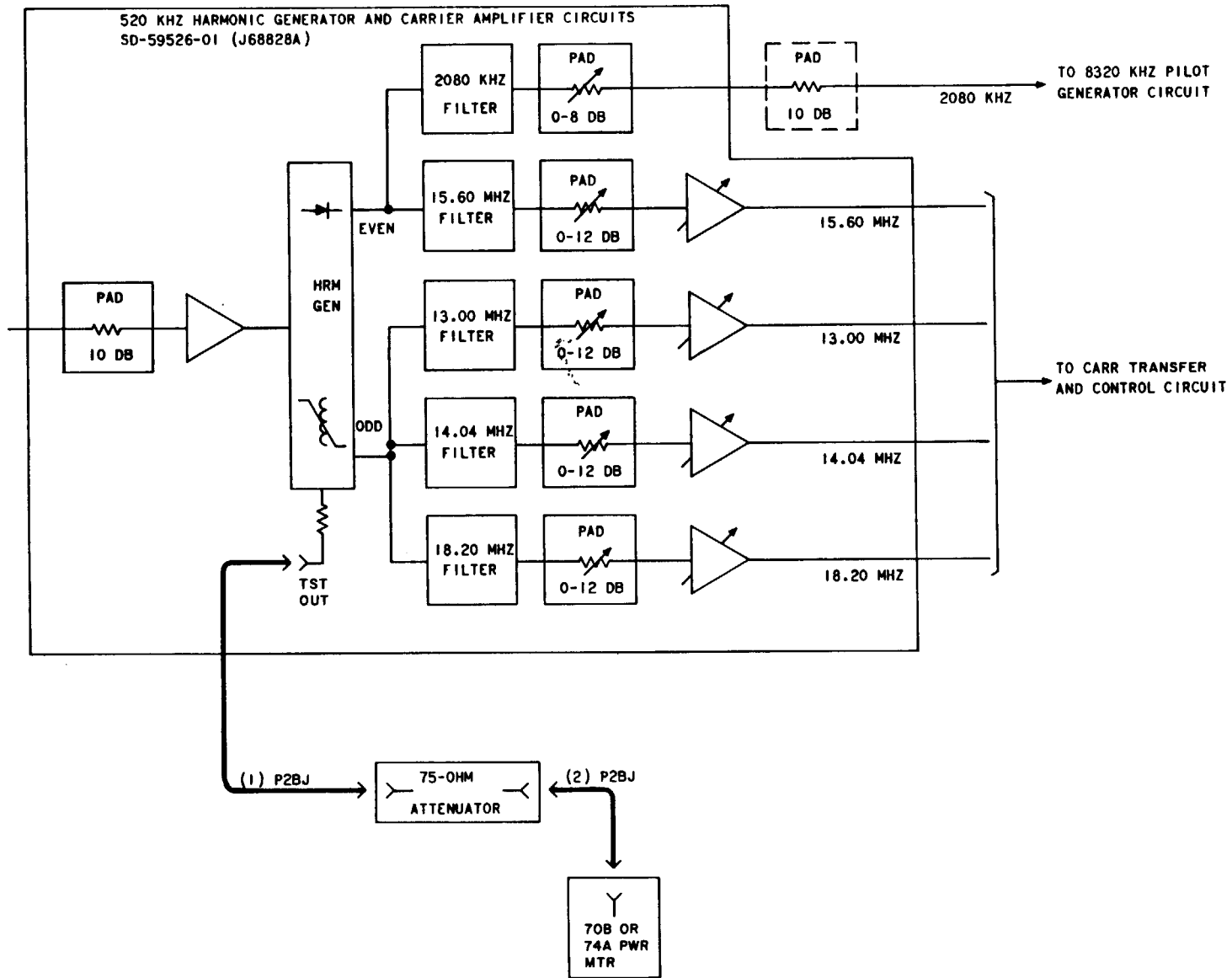

Fig. 2—Measurement of 520-kHz Harmonic Generator at TST OUT Jack