

**L MULTIPLEX TERMINALS**  
**LMX-2**  
**TRANSMITTING CIRCUITS**  
**GROUP MODULATOR**  
**TURNOVER TESTS**

**PURPOSE OF TESTS**

To determine that no wiring turnover exists in the group bank hybrid or in the individual group modulator circuits.

**REASON FOR ISSUE**

The information in this section was previously in *Section 356-215-514 which is now cancelled*. It is renumbered during the process of reorganizing the 356- division of practices. *Equipment Test Lists are affected.*

**SYNOPSIS (SEE FIG. 1)**

Each group modulator circuit in a group bank:

- (a) Accepts the 60- to 108-kHz frequency band, at  $-42$  dBm, from either the output of a channel bank or group connector
- (b) Amplifies this signal with a 231A amplifier which has a nominal gain of 8.3 dB with a  $\pm 2$  dB adjustment range
- (c) Translates this signal to its allocated slot in the 312- to 552-kHz supergroup band.

This translated signal is combined with the translated signals from four other group modulator circuits. The combined signals are amplified by a 231B amplifier, which has a nominal gain of 28 dB, and are delivered to the GR BK OUT jacks at  $-25$  dBm. Hence, a gain of 17 dB exists between the GR MOD IN jacks and the GR BK OUT jacks.

**NEED FOR TURNOVER TESTS**

Spare group bank equipment is provided in the LMX-2 terminal for replacing failed regular equipment. In order that proper operation will prevail when the spare equipment is patched in place of the regular equipment, there shall be no turnover in either the spare or regular equipment.

**APPARATUS:**

The tests in this section require suitable transmission test equipment. Refer to Section 356-010-500 and select, from available equipment, sending and receiving units having the following capabilities:

**Sending test equipment** capable of delivering, into 135-ohm circuits, a 104.08-kHz signal at a level of -42 dBm

**Receiving test equipment** capable of detecting, from 75-ohm circuits, signals between 312 kHz and 552 kHz at a level of -25 dBm.

In addition to the above, the following are required:

**135-Ohm Multiple Jacks**

**75-Ohm Multiple Jacks**

**3P20B Cords**, as required

**P2BJ Cords**, as required

STEP	PROCEDURE																							
<p>1</p> <p>2</p>	<p><b>Hybrid Turnover (See Fig. 1)</b></p> <p>Verify that the equipment to be tested is out of service.</p> <p>Prepare the receiving test equipment for a 75-ohm terminated measurement of 315.92 kHz at -25 dBm (translated group 1 pilot).</p> <p><i>Note:</i> The translated 104.08-kHz group pilots are given in Table A.</p> <p style="text-align: center;"><b>TABLE A</b></p> <table border="1" style="margin-left: auto; margin-right: auto;"> <thead> <tr> <th colspan="6" style="text-align: center;">FREQUENCY TRANSLATION (GROUP MODULATORS)</th> </tr> <tr> <th rowspan="2" style="text-align: center;">INPUT PILOT FREQUENCY (KHZ)</th> <th colspan="5" style="text-align: center;">OUTPUT PILOT FREQUENCY (KHZ) FOR GROUPS 1 THROUGH 5</th> </tr> <tr> <th style="text-align: center;">1</th> <th style="text-align: center;">2</th> <th style="text-align: center;">3</th> <th style="text-align: center;">4</th> <th style="text-align: center;">5</th> </tr> </thead> <tbody> <tr> <td style="text-align: center;">104.08</td> <td style="text-align: center;">315.92</td> <td style="text-align: center;">363.92</td> <td style="text-align: center;">411.92</td> <td style="text-align: center;">459.92</td> <td style="text-align: center;">507.92</td> </tr> </tbody> </table>	FREQUENCY TRANSLATION (GROUP MODULATORS)						INPUT PILOT FREQUENCY (KHZ)	OUTPUT PILOT FREQUENCY (KHZ) FOR GROUPS 1 THROUGH 5					1	2	3	4	5	104.08	315.92	363.92	411.92	459.92	507.92
FREQUENCY TRANSLATION (GROUP MODULATORS)																								
INPUT PILOT FREQUENCY (KHZ)	OUTPUT PILOT FREQUENCY (KHZ) FOR GROUPS 1 THROUGH 5																							
	1	2	3	4	5																			
104.08	315.92	363.92	411.92	459.92	507.92																			
<p>3</p>	<p>Prepare the sending test equipment to deliver a 104.08-kHz pilot at -42 dBm.</p>																							
<p>4</p>	<p>Make patches (1), (2), and (3) in Fig. 1.</p>																							

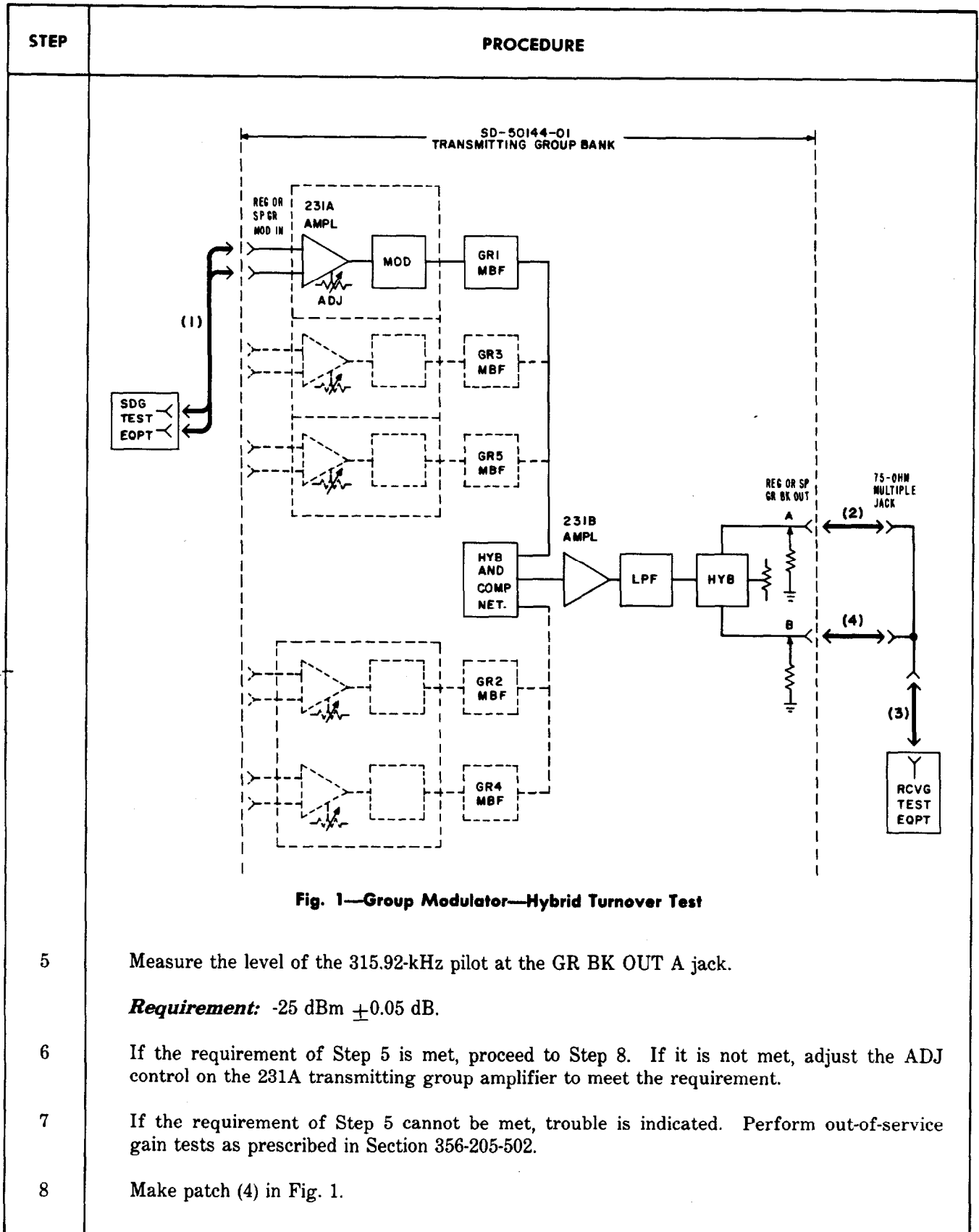

## SECTION 356-205-503

STEP	PROCEDURE
9	<p>Measure the combined level of the 315.92-kHz pilot at the paralleled GR BK OUT A and B jacks.</p> <p><b>Requirement:</b> Between <math>-23.5</math> dBm and <math>-21.5</math> dBm.</p>
10	<p>If the requirement of Step 9 is met, proceed to Step 12. If it is not met, turnover exists in the group output hybrid. Locate and correct the trouble.</p>
11	<p>Repeat Steps 5 through 10 to verify correction of the trouble.</p>
12	<p>Repeat Steps 2 through 10 for each regular and spare group bank to be tested.</p>
13	<p>Remove patches (1) and (4) in Fig. 1.</p> <p><b>Group Turnover (See Fig. 2)</b></p>
14	<p>Select a modulator circuit for testing in the <i>regular</i> group bank.</p>
15	<p>Verify that the test equipment is connected to the selected circuit [patches (1), (2), (3), and (4), Fig. 2].</p>
16	<p>Connect the 75-ohm multiple jack to the identically-numbered modulator circuit (same as the modulator circuit selected in Step 14) in the spare group bank [patch (5), Fig. 2].</p>
17	<p>Measure and record the level of the 315.92-kHz pilot at the regular GR BK OUT A jack.</p>
18	<p>Remove patch (2) and make patch (6) in Fig. 2.</p>
19	<p>Measure the level of the 315.92-kHz pilot at the spare GR BK OUT A jack.</p> <p><b>Requirement:</b> Same value as that recorded in Step 17.</p>
20	<p>If the requirement of Step 19 is met, proceed to Step 21. If it is not met, adjust the associated ADJ control to meet the requirement.</p>
21	<p>Make patch (2) in Fig. 2.</p>
22	<p>Measure the combined level of the 315.92-kHz pilot at the paralleled regular and spare GR BK OUT A jacks.</p> <p><b>Requirement:</b> Not more than a 2-dB <i>decrease</i> from the value recorded in Step 17.</p>
23	<p>If the requirement of Step 22 is met, proceed to Step 25. If it is not met, turnover exists in the regular or spare group modulator circuit being tested.</p>
24	<p>Locate and correct the trouble and repeat Steps 17 through 23.</p>
25	<p>Repeat Steps 14 through 23 for each <i>identically numbered</i> regular and spare group modulator circuit to be tested.</p>
26	<p>Remove patches (1), (2), (3), (4), (5), and (6) in Fig. 2.</p>
27	<p>Restore service to normal.</p>

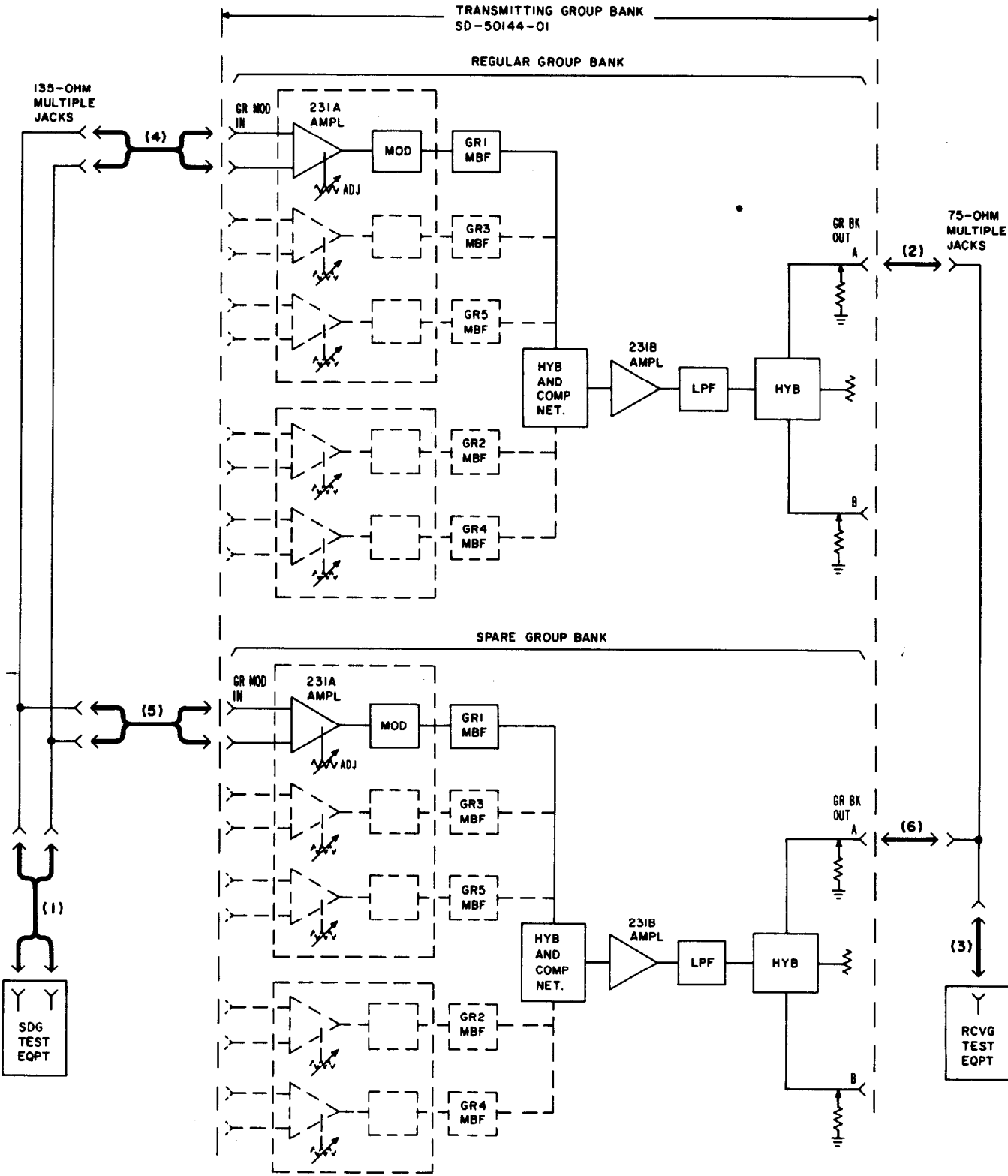

Fig. 2—Group Modulator—Group Turnover Test