ANALOG MULTIPLEX TERMINAL EQUIPMENT
LMX-2
SUPERGROUP CARRIER SUPPLY
DRIVE AMPLIFIER TESTS

This section provides procedures to measure the voltage and output power of the supergroup carrier drive amplifiers (Fig. 1, 2, and 3).

This section is reissued to clarify the output power requirements. Arrows are used to indicate significant changes. *Equipment Test Lists are not affected.*

A 124-kHz harmonic generator and an 80-kHz harmonic generator are required to produce the supergroup carrier frequencies for U300, U600, and L1860A multiplex terminals (Fig. 2). A 124-kHz harmonic generator is required to produce supergroup carrier frequencies for L600A multiplex terminals (Fig. 3).

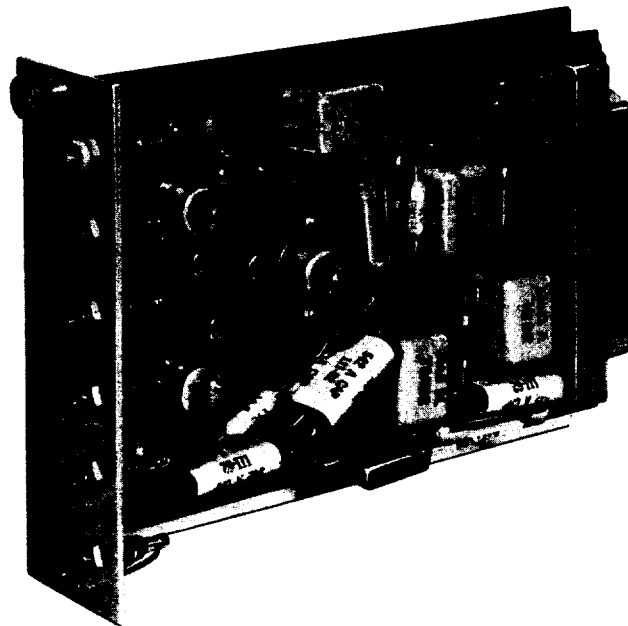

Fig. 1—Supergroup Carrier Drive Amplifier

NOTICE

Not for use or disclosure outside the
Bell System except under written agreement

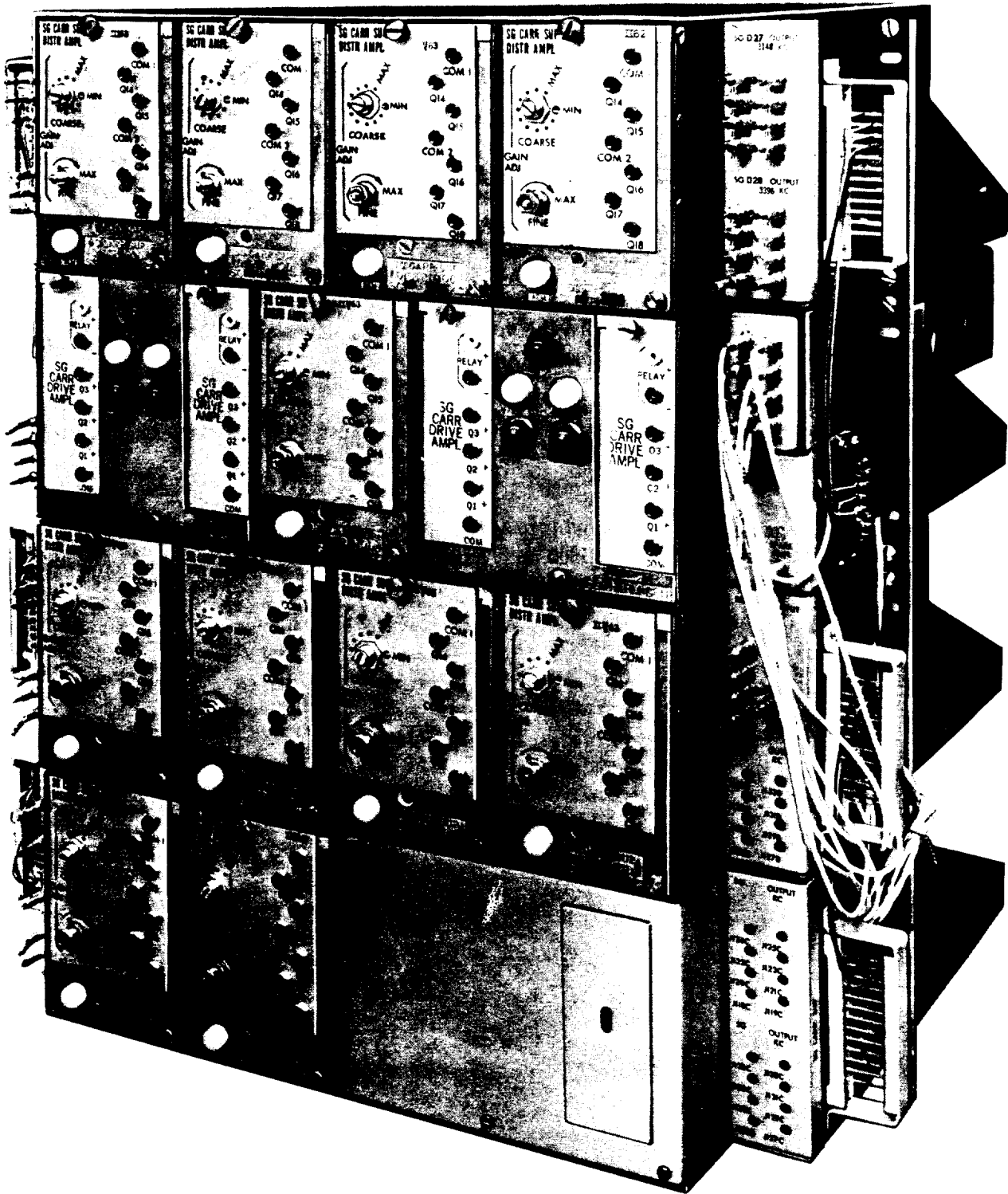

Fig. 2—Supergroup Carrier Supply Unit

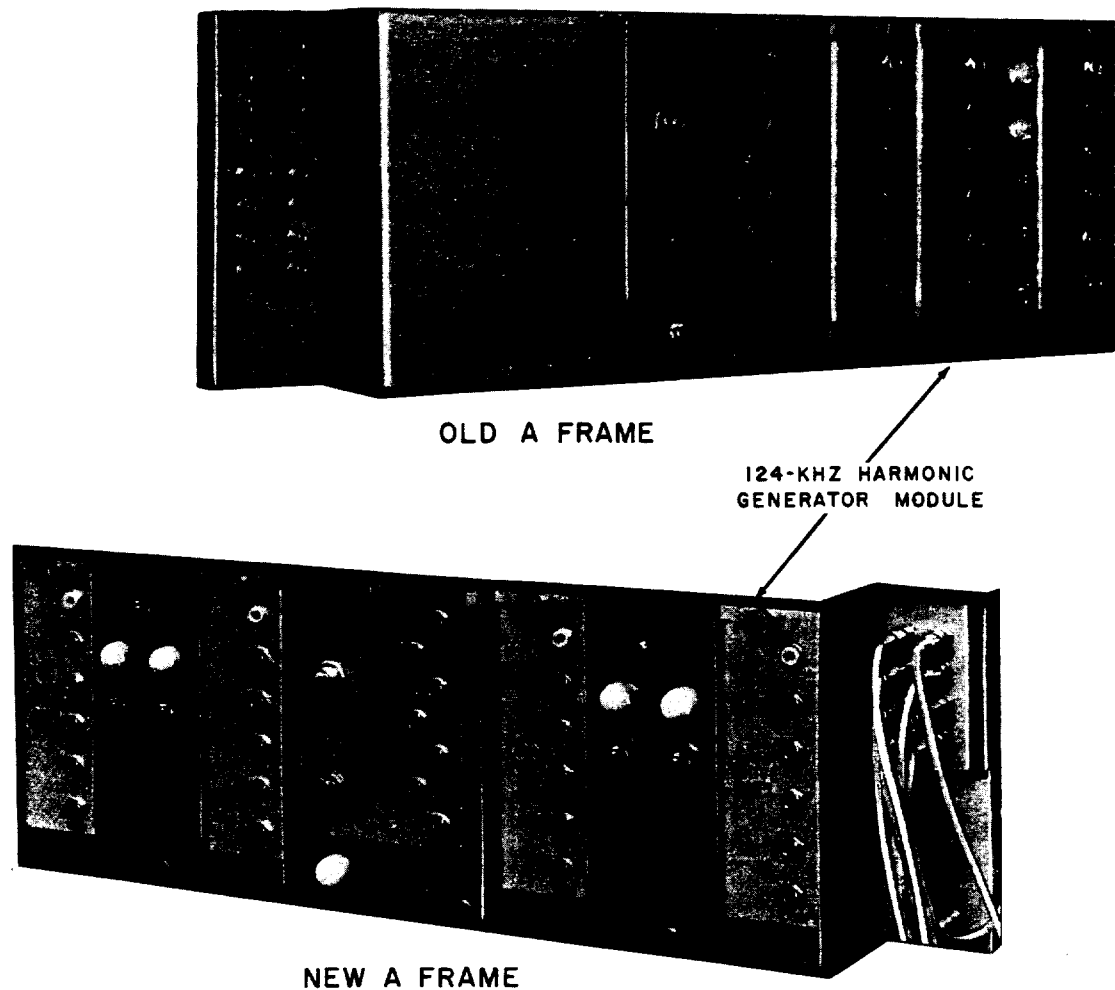

Fig. 3—Supergroup Carrier 124-kHz Harmonic Generator

In the U300, U600, and L1860A terminals, the 80-kHz and 124-kHz harmonic generator modules each contain two identical plug-in supergroup carrier drive amplifiers which amplify the 80-kHz and 124-kHz harmonic inputs from the intermediate frequency supply. One amplifier for each frequency is in the working condition; the other amplifier is on standby as indicated by the lighted green READY lamp. Neither amplifier has priority, and there is no provision for manual switching.

In the L600A terminal, the 124-kHz harmonic generator module contains two or three identical plug-in amplifiers (Fig. 3). One amplifier is in the working condition, one is on standby as indicated by a lighted green READY lamp, and one is a spare with no signal input. On the newer L600A terminals, the spare amplifier has been omitted (Fig. 3).

CHART	PAGE
1—SUPERGROUP CARRIER DRIVE AMPLIFIERS	4
A. Voltage Test	4
B. Output Power Test	6

APPARATUS:

The tests in this section require suitable transmission test equipment.

Refer to Section 356-010-500 and select, from available equipment, receiving units having the following capabilities:

Receiving test equipment (RTE) capable of detecting, from 75-ohm circuits, signals at 80 kHz and 124 kHz at powers between -4.5 and +3 dBm.

Note: A thermocouple-type power meter is required for these tests (34A TMS or equivalent).

Volt-Ohm-Milliammeter (VOM) KS-14510 or other dc voltmeter with a sensitivity of at least 20,000 ohms per volt.

Capacitor 542F (2 mfd) or KS-19107, List 5 (2 mfd).

P2BJ Cord.

CHART 1**SUPERGROUP CARRIER DRIVE AMPLIFIERS**

STEP	PROCEDURE
	A. Voltage Test
	Caution: <i>Ensure the correct polarity connection of the VOM.</i>
1	Measure the dc voltage at each test jack on the drive amplifier under test per Table A [patch (1), Fig. 4].
	Requirement: See Table A.
2	Remove the VOM test connections.
3	Proceed to Part B if the requirement is met. Otherwise, proceed to Step 4.

CHART 1 (Cont)

TABLE A

VOM TEST CONNECTIONS		REQUIREMENTS (VOLTS DC)	
POS (+)	NEG (-)	80-KHZ HRM GEN	124-KHZ HRM GEN
Relay + (Note 1) *	Relay - *	2.7 MIN	2.7 MIN
Relay + (Note 2) *	Relay - *	6.0 MIN	6.0 MIN
Q3 + †	COM	0.2 to 1.6	0.2 to 1.4
Q2 + †	COM	0.2 to 1.6	0.2 to 1.4
Q1 + *†	COM	6.4 ±0.7	6.4 ±0.7

Note 1: Harmonic generator units containing mercury relay alarm circuit per ED-50108.

Note 2: Harmonic generator units containing miniature relay alarm circuit per ED-50116.

* Test jacks omitted in later manufacture.

† A 542F (2mfd) or KS-19107 List 5 (2mfd) capacitor must be bridged across the VOM test leads for this measurement.

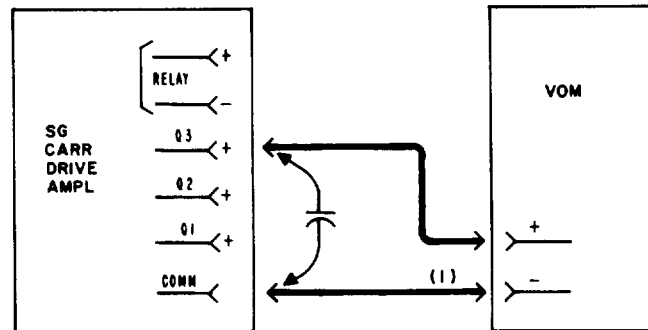

Fig. 4—Supergroup Carrier Drive Amplifier Voltage Tests

CHART 1 (Cont)

STEP	PROCEDURE
4	Replace the drive amplifier under test.
5	Repeat Steps 1 through 4, as required.
	B. Output Power Test
6	Calibrate the RTE for a 75-ohm terminated measurement at 124 kHz or 80 kHz, according to the drive amplifier under test. <i>Note:</i> Calibrate at -1.0 dBm for L600A and L1860A terminals, or calibrate at -4.5 dBm for U300 terminals.
7	Connect the RTE to the appropriate carrier test panel in accordance with Fig. 5.
8	Set the carrier test switch, if provided, in accordance with Table B. <i>Note:</i> A carrier test switch is not provided on supergroup carrier test panel ED-51249.
9	Measure the output power of 80-kHz drive amplifier 1. <i>Requirement:</i> -1.0 dBm minimum for L600 and L1860A terminals; -4.5 dBm minimum for U300 terminals.
10	Proceed to Step 13 if the requirement is met. Otherwise, proceed to Step 11.
11	Replace the drive amplifier under test.
12	Repeat Steps 7 through 10 for the new drive amplifier. <i>Note:</i> If replacing the drive amplifier does not clear the trouble, check the output power of the intermediate frequency supply per Section 356-260-501. If the trouble still is not cleared, perform trouble location procedures per Section 356-270-505.
13	Repeat Steps 7 through 12, as required, for the other 80-kHz drive amplifier.
14	Repeat Steps 6 through 13, as required, for the 124-kHz drive amplifiers 1 and 2.
15	Remove patch (1), Fig. 5.
16	Set the carrier test switch to the OFF position.

TABLE B

SUPERGROUP CARRIER SUPPLY TEST PANEL

DRIVE AMPLIFIER	L600A				U600 - L1860A (OLD)		L1860A (NEW)		
	OLD PANEL		J68857J PANEL		J68857J PANEL		ED-51249-30 PANEL		
	CARR TST SWITCH POSITION	TEST JACK	CARR TST SWITCH POSITION	TEST JACK	CARR TST SWITCH POSITION	TEST JACK	CARR TST PANEL	TEST JACK	
124 KHZ	1	Super- group HG AMPL 1	CARR TST	Super- group MOD POS 3	CARR TST 1	Super- group MOD POS 3	CARR TST 1	124 KHZ TST	TST 1
	2	Super- group HG AMPL 2	CARR TST	Super- group MOD POS 3	CARR TST 2	Super- group MOD POS 3	CARR TST 2	124 KHZ TST	TST 2
80 KHZ	1	—	—	—	—	Super- group MOD POS 1	CARR TST 1	80 KHZ TST	TST 1
	2	—	—	—	—	Super- group MOD POS 1	CARR TST 2	80 KHZ TST	TST 2

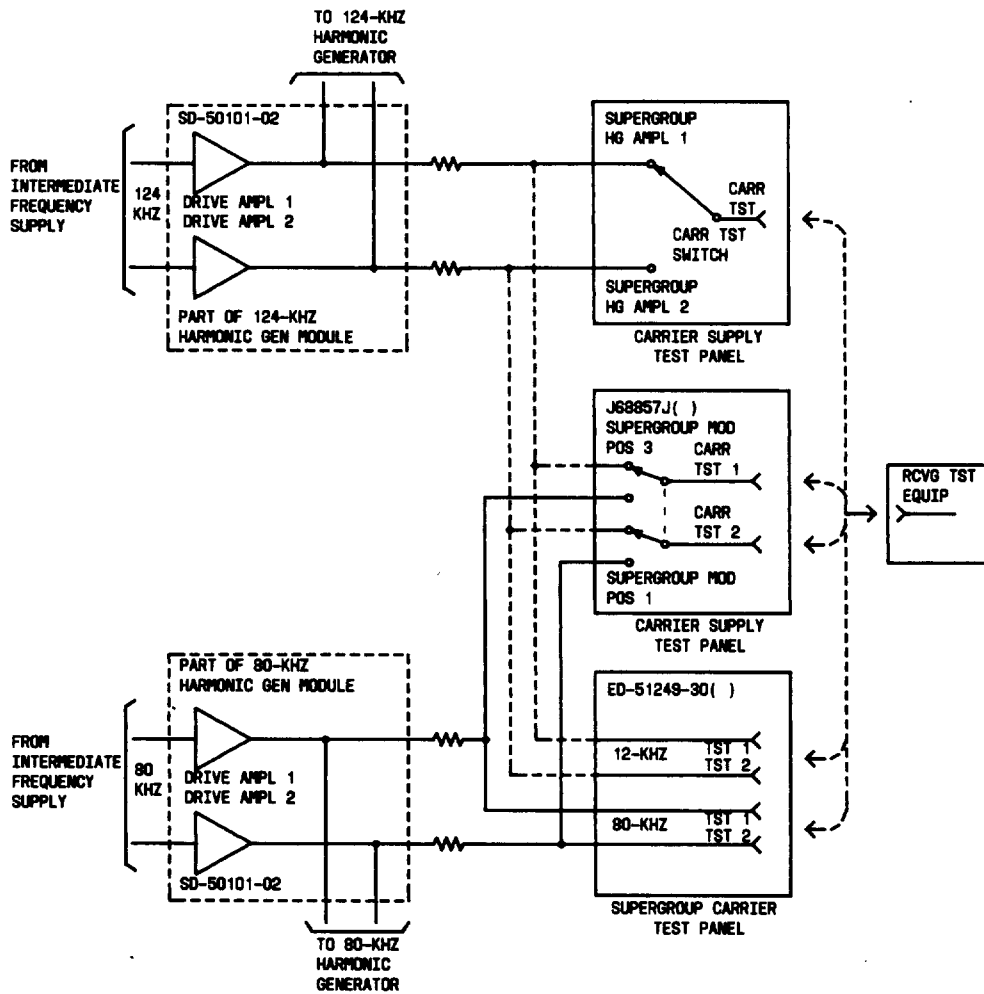

Fig. 5—Supergroup Carrier Driver Amplifier Output Power Test