GROUP MODULATOR IN-SERVICE GAIN ADJUSTMENT
L60A/L120A MULTIPLEX TERMINALS
LMX-2 TRANSMITTING CIRCUITS
ANALOG MULTIPLEX TERMINAL EQUIPMENT

The purpose of this test is to measure the output power of the translated group pilot of each group in a group bank and, if necessary, to adjust the output of each group circuit in turn to meet the requirement.

This section is reissued to correct errors and to improve the test procedure. Due to the general revision, arrows are not used to indicate changes. *Equipment Test Lists are not affected.*

The design of L60A and L120A terminals requires a gain of 17.0 dB in each group modulator. The basic group band (60 to 108 kHz) received from a channel bank or group connector at a -42 dB transmission level is individually amplified and translated to one of five band spaces in the basic supergroup band (312 to 552 kHz). This band is then amplified by the transmitting intermediate fixed-gain amplifier to a transmission level of -25 dB, which is required at the input of the supergroup modulator.

To provide compensation for equipment variations, the overall gain of each group is adjusted by the ADJ potentiometer in the group transmitting amplifier (Fig. 1). The nominal gain of a group transmitting amplifier is 8.3 dB. The ADJ potentiometer allows the gain to be varied over a 4-dB range. The following transmitting intermediate amplifier provides a fixed gain for all groups in the group bank.

A translated group pilot which is 20 dB below transmission level is used to adjust the group modulator gain on an in-service basis. When measuring a 104.08-kHz or a 315.92-kHz pilot signal using general purpose test equipment, a pilot filter set is required for group 1 if pilot insertion units are not equipped with a carrier leak blocking filter.

APPARATUS:

The tests in this section require suitable transmission test equipment. Refer to Section 356-010-500 and select, from available equipment, a receiving unit having the following capabilities:

Receiving test equipment (RTE) capable of detecting, from 75-ohm circuits, signals between 104 and 520 kHz at powers between -40 and -65 dBm

P2BJ Cords

Pilot Filter Set J68858AT (Section 103-407-101) is required for measurements of group 1 pilot if pilot insertion units are not equipped with a carrier leak blocking filter.

NOTICE

Not for use or disclosure outside the
Bell System except under written agreement

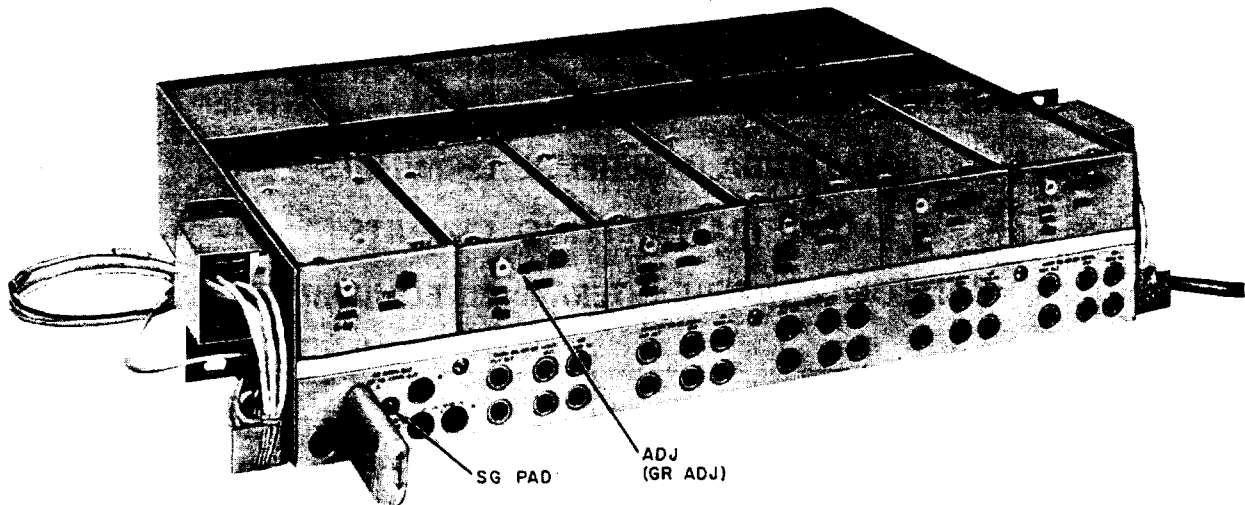

Fig. 1—Transmitting Group Bank Shelf Assembly

STEP

PROCEDURE

A. Adjust Gain For Group 1

Note: The transmitting amplifier for group 1 is adjusted in this part. The transmitting amplifiers for groups 2 through 5 are adjusted in Part B. The requirements in this section are based on the assumption that the 104.08-kHz group pilot power at the GR MOD IN jack is $-62.0 \text{ dBm} \pm 0.1 \text{ dB}$ for each group (Section 356-011-503).

- 1 Prepare the RTE for a 75-ohm terminated measurement of a 315.92-kHz pilot signal (translated 104.08-kHz pilot signal) at -45 dBm , or -55 dBm if pilot filter set is used.

Caution: *Ensure that a 1000-Hz test signal is not present on channel 2 of the group 1 under test. Presence of such a test signal can cause a measurement error.*

- 2 Connect the RTE to the GR BK OUT B jack [patch (1), Fig. 2].

Note: If the supergroup being measured is equipped with a supergroup connector instead of a group bank, connect the RTE to the SG CONN OUT B jack.

- 3 Measure the 315.92-kHz power of the group 1 pilot signal.

Requirement: $-45.0 \text{ dBm} \pm 0.1 \text{ dB}$

Note: Signal power will be 10 dB lower (-55 dBm) if pilot filter set is used.

- 4 Proceed to Step 7 if the requirement is met. Otherwise, proceed to Step 5.

STEP	PROCEDURE
5	Adjust the ADJ control (Fig. 1) on the transmitting group amplifier for group 1 to meet the requirement. <i>Note:</i> If the supergroup being measured is equipped with a supergroup connector, adjust the GAIN control (C1 supergroup connector) or adjust the ADJ control (C2 supergroup connector) to meet the requirement.
6	Perform out-of-service tests in Section 356-281-503 to locate trouble if the requirement in Step 3 cannot be met.
7	Disconnect the test equipment from the test jack.
B. Adjust Gain for Groups 2 Through 5	
8	Prepare the RTE for a 75-ohm terminated measurement of the translated group pilot signal for group 2 at -63.4 dBm. <i>Note:</i> Table A lists the translated group pilot frequencies. <i>Caution:</i> Connect the patch cord to the test equipment before making the connection to the SG BK OUT TST jack.
9	Connect the RTE to the SG BK OUT TST jack.
10	Measure the power of the translated group pilot for group 2. <i>Requirement:</i> -63.4 dBm \pm 0.1 dB
11	Adjust the ADJ control on the transmitting group amplifier for the group under test to meet the requirement.
12	Repeat Steps 8 through 11 for groups 3 through 5.
13	Remove all test equipment. <i>Note:</i> Pilot signal power for each group may be measured at the GR BK OUT B jack and recorded for future reference. Recorded power values may be useful during trouble locating. Group pilot signal powers should be -45.0 dBm \pm 2.0 dB at the GR BK OUT B jack.

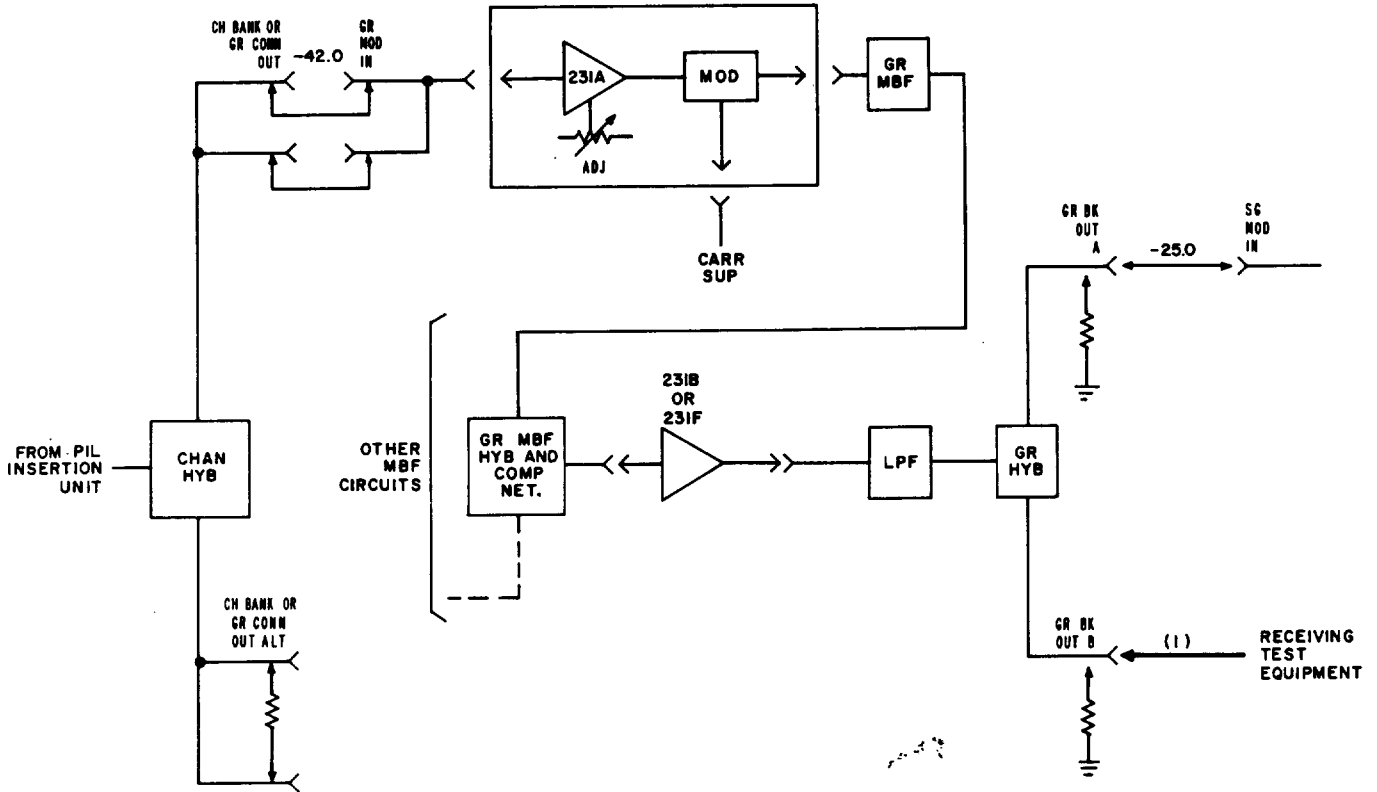

Fig. 2—Group Modulator In-Service Gain Adjustment

TABLE A

TRANSLATED GROUP PILOT FREQUENCIES

GROUP	1	2	3	4	5
Translated 104.08-kHz Input	315.92*	363.92	411.92	459.92	507.92

* Use the pilot filter set for group 1 measurement where pilot insertion unit is not equipped with a carrier leak blocking filter.