

DS2 INTERFACE UNIT (DS2 INF:X0308)  
FUNCTIONAL DESCRIPTION

1. GENERAL

- 1.01 This section is a cover sheet for the NEC America, Inc., DS2 Interface Unit (DS2 INF:X0308) Functional Description. This section is reproduced with permission of NEC America, Inc., and is equivalent to NEC practice NECA 365-407-405, Issue 1.
- 1.02 Whenever this section is reissued the reason(s) for reissue will be listed in this paragraph.
- 1.03 This section provides a general description of the DS2 Interface Unit (DS INF:X0308-).
- 1.04 If corrections are required in the attached document, use Form-3973 as described in Section 000-010-015.
- 1.05 If equipment design and/or manufacturing problems should occur, refer to Section SW 010-522-906 for procedures on filing an Engineering complaint.

2. ORDERING PROCEDURE

- 2.01 The DS Interface Unit (DS INF:X0308) may be ordered via the Southwestern Inventory Management System (SWIMS).
- 2.02 To order additional copies of this practice, use NECA 365-407-816SW as the section number.

3. REPAIR/RETURN

- 3.01 Malfunctioning units may be returned to NEC America, Inc., for repair.

Attachment: NEC America, Inc.  
DS2 Interface Unit (DS2 INF:X0308)  
Functional Description

PROPRIETARY

Not for use or disclosure outside Southwestern Bell  
Telephone Company except under written agreement.

**DS2 INTERFACE UNIT (DS2 INF : X0308)  
FUNCTIONAL DESCRIPTION**

---

**NEC America, Inc.**  
**Transmission Division**

14040 Park Center Road  
Herndon, Virginia 22071  
Phone No: (703) 834-4000  
Fax No: (703) 481-6904  
Telex No: 899498  
TWX No: 710-831-0639  
Easylink No: 62939917

DS2 INTERFACE UNIT (DS2 INF)  
 X0308-OA00/OA01/OB00  
 FUNCTIONAL DESCRIPTION

CONTENTS		Page
1. GENERAL .....		2
2. DESCRIPTION .....		2
3. FUNCTIONAL OPERATION .....		3
A. XMT Data Path .....		3
B. RCV Data Path .....		5
C. Switching .....		5
D. Alarm Function .....		5
4. INDICATORS .....		6
5. STRAPPING SELECTION .....		8

ILLUSTRATIONS

Figure	Title	Page
3-1	DS2 INF Unit Block Diagram .....	4
4-1	DS2 INF Unit Indicators .....	7

TABLES

Table	Title	Page
2-1	DS2 INF Unit Group .....	3
4-1	DS2 INF Unit Indicators .....	6

Copyright © 1986 by NEC America Inc. All rights reserved.

This document is not an offer to sell. The information contained in this document is subject to change without notice.

## 1. GENERAL

1.01 This practice provides a general description of the DS2 interface unit (DS2 INF: X0308- ) and contains the following information:

- (1) Description
- (2) Functional operation
- (3) Indicators
- (4) Strapping selection

1.02 Whenever this practice is reissued, the reason for reissue will be listed in this paragraph.

## 2. DESCRIPTION

2.01 This unit consists of one epoxy-glass printed wire board (PWB) and associated circuit components. Printed circuit wiring is etched on both sides of the PWB.

2.02 LEDs for indicating the operational status are located on the front edge of this unit.

2.03 This unit is mounted in the FD-2240A E8980 shelf with back board connectors J19 (Sys 1), J16 (Sys 2), J10 (Sys 3) and J7 (Sys 4), in case that high speed interface is bipolar. The unit inputs and outputs are terminated at the connector on the rear of this PWB.

2.04 The unit designation, unit code, manufacturing date and serial No. are printed on the right side surface of the connector.

2.05 The lower front edge of the PWB is fitted with ejector to facilitate insertion and removal of the board from the shelf. A CLEI and bar code label is placed on the surface of the ejector. See Figure 4-1.

2.06 There are three groups for DS2 INF unit. Table 2-1 lists these groups.

Table 2-1  
DS2 INF Unit Group

No.	Unit Code and Group	Power Voltage	Line Code	Remarks
1	X0308A	-48 Vdc	B6ZS	Primary version
2	X0308A1	-48 Vdc	B6ZS	New version
3	X0308B	-24 Vdc	B6ZS	

### 3. FUNCTIONAL OPERATION

3.01 The DS2 INF unit converts 6.312 Mb/s unipolar signal incoming from the MUX unit into bipolar signal and sends it out to DS2 line. And it also converts 6.312 Mb/s bipolar signal incoming from DS2 line into unipolar signal and sends it out to the DMUX unit. Block diagram of this unit is shown in Figure 3-1.

#### A. XMT Data Path

3.02 6.312 Mb/s data (6M XMT DATA) and clock (6M XMT CLK) signals enter the unit and go to a B6ZS CODER. The 6M XMT CLK signal also goes to a uniplar-to-bipolar and converter (U/B CONV). The U/B CONV converts the data to bipolar form and sends the resulting bipolar signal to a cable length equalization network.

3.03 After passing through the cable length equalization network (120 FT EQL, 240 FT EQL, 480 FT EQL, 960 FT EQL) the bipolar signal goes to a relay switch (RLY SW).

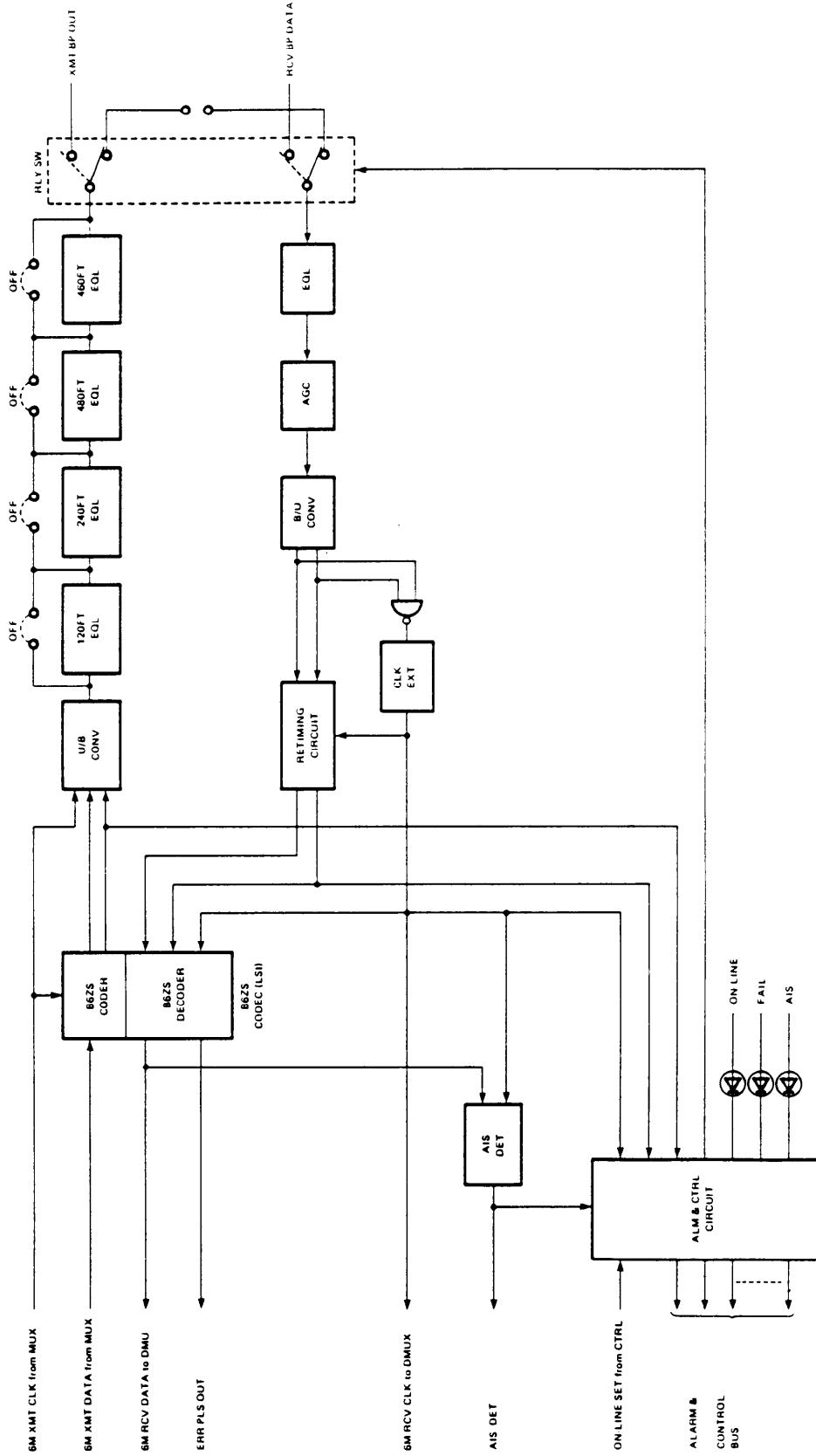

◆ Figure 3-1 DS2 INF Unit Block Diagram ◆

## B. RCV Data Path

3.04 Incoming 6.312 Mb/s BP signal is sent to the EQL and AGC section through RLY SW. At EQL and AGC section, characteristics compensation for 1,000 - 2,000 ft cable length is provided.

3.05 The AGC circuit output goes to a bipolar-to-unipolar converter (B/U CONV). The B/U CONV converts the bipolar data to unipolar (TTL levels) form. The unipolar data go to a RETIMING CIRCUIT and a clock extractor (CLK EXT) circuit. The CLK EXT circuit extracts the line clock signal and regenerates the 6M RCV CLK signal. The 6M RCV CLK goes to the RETIMING CIRCUIT and B6ZS DECODER.

3.06 After reidentification in the RETIMING CIRCUIT, the unipolar data go to a B6ZS DECODER. The decoded data then go to the DMUX unit.

## C. Switching

3.07 At SW control section, relay switching is operated by incoming ON LINE information from the CTRL unit and lights the ON LINE indicator LED when in on line.

## D. Alarm Function

3.08 At ALM DET, ALM & CTRL CIRCUIT and AIS DET section, data loss detection of XMT side and RCV side and AIS detection of RCV side are facilitated. If such losses are detected, it will light FAIL indication LED or AIS indication LED respectively. Data loss detection is executed for output data from B6ZS CODER and input data to B6ZS DECODER and AIS detection is performed for output data from B6ZS DECODER. ALM DET section sends out ON LINE, AIS DET, data loss of XMT side and RCV side information to the ALM unit and CTRL unit. Also light the corresponding LED.

4. INDICATORS

4.01 Table 4-1 and Figure 4-1 show indicators on the DS2 INF unit. Physical location of indicators are shown in Figure 4-1.

Table 4-1  
DS2 INF Unit Indicators

Feature	Type	Indicator	Function
Status	Green LED	ON LINE	Lights when this unit is used as on line circuit
Alarm	Red LED	FAIL	Lights when an alarm occurs in this unit
Status	Amber LED	AIS	Lights when detects AIS from remote station



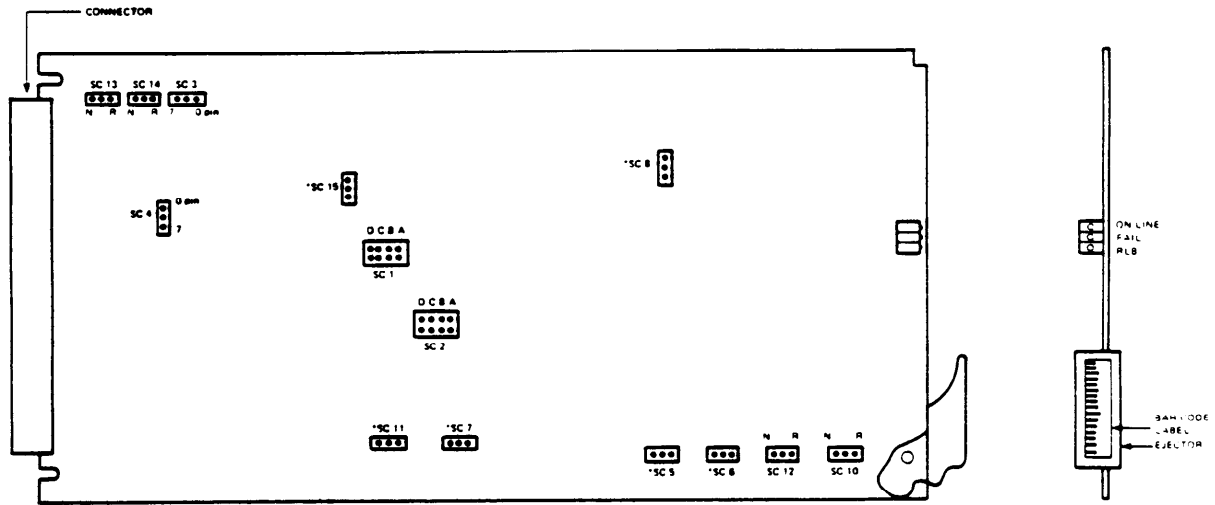

\* Factory adjustment

(A) DS2 INF (Grp: 0A00) Unit

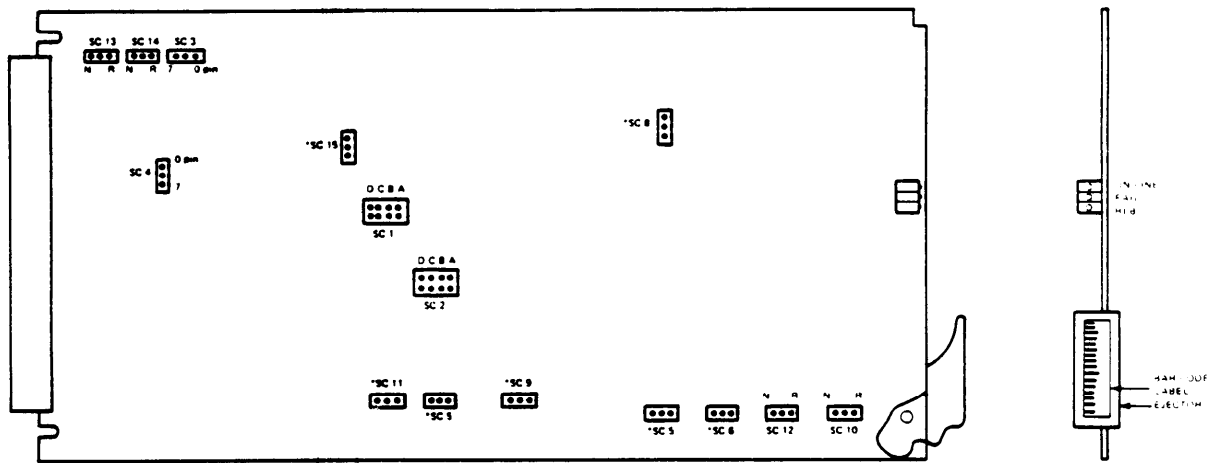

\* Factory adjustment

◆ (B) DS2 INF (Grp: 0A01/0B00) Unit ◆

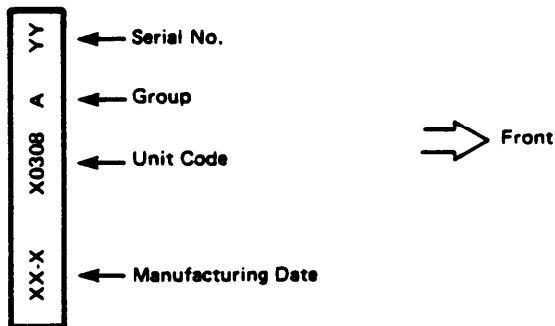

NOTE: Printed on the right side surface of connector.

◆ Figure 4-1 DS2 INF Unit Indicators ◆

NECA 365-407-405  
CHANGE-7

## 5. STRAPPING SELECTION

5.01 There are 14 strapping locations on this unit (Grp: 0A00, 0A01 and 0B00) as shown in Figure 4-1. Detailed strapping selections are described in NEC practice NECA 365-407-203.