

OVER-THE-HORIZON RADIO SYSTEMS
2-GHZ OVER-THE-HORIZON RADIO SYSTEM
ITTIL NUS 3653-8 10-KW POWER AMPLIFIER
MECHANICAL PROCEDURES
KLYSTRON REPLACEMENT

This section describes the mechanical procedures required in replacing the power amplifier klystron. The replacement is accomplished in four sequential stages, as follows:

- (a) Klystron coolant draining
- (b) Klystron removal
- (c) New klystron preparation
- (d) Klystron installation.

The safety precautions contained in Section 010-110-001 apply to this chart.

CHART 1
KLYSTRON REPLACEMENT

STEP	PROCEDURE
1	Complete the power amplifier shut-down procedure contained in Section 403-405-300. A. Klystron Coolant Draining
2	Operate the CONTROL and HEAT EXCHANGER circuit breakers to the OFF position.
3	Operate the MAIN DISCONNECT switch to the ON position.
4	In the lower klystron compartment, open gate valves V3, V7, and V8. Close gate valves V4 and V9. See Fig. 1.
5	Operate the HEAT EXCHANGER circuit breaker to the ON position. Wait approximately 5 minutes before proceeding.
6	Close valves V7 and V8.

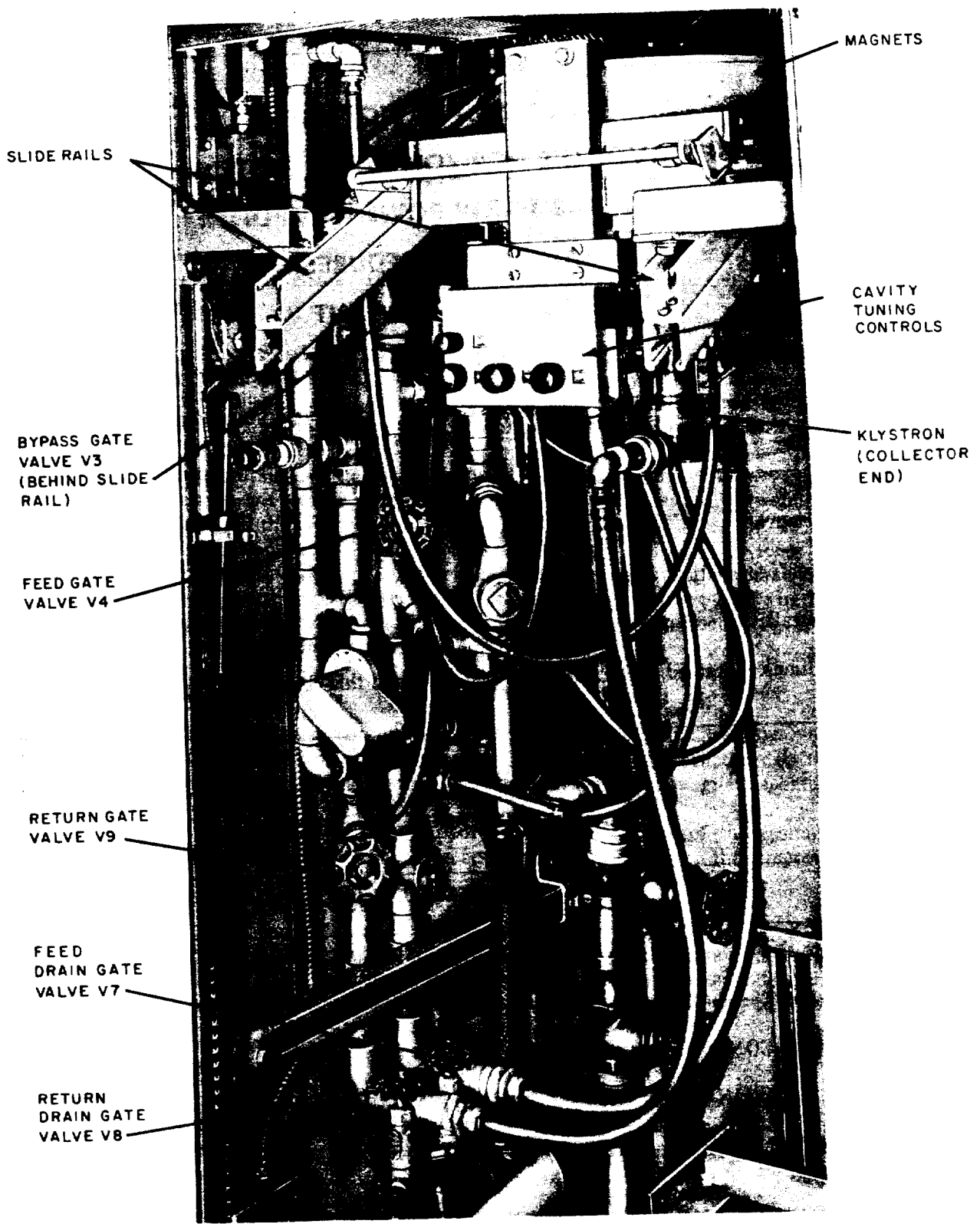
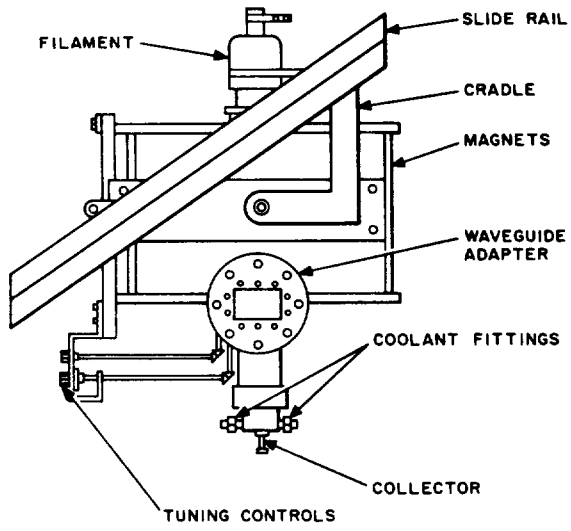
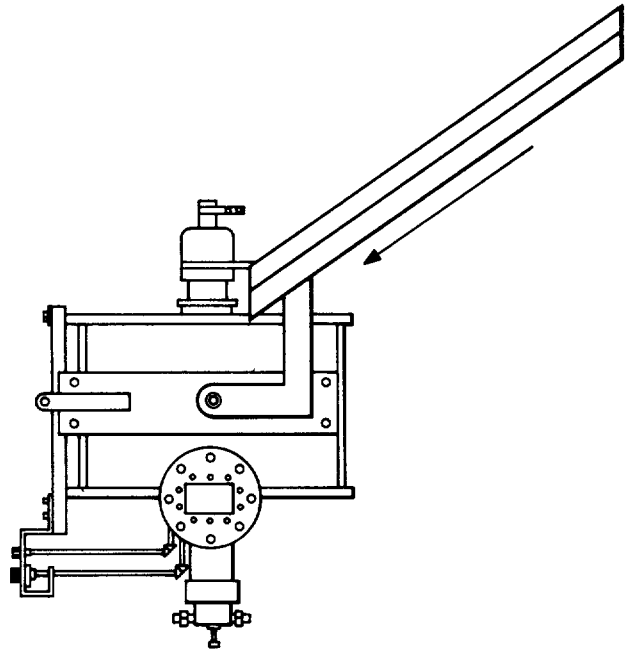

Fig. 1—Klystron Bay—Coolant Plumbing

CHART 1 (Cont)	
STEP	PROCEDURE
7	Disengage all coolant hoses from the klystron and magnet assembly.
8	Operate the HEAT EXCHANGER circuit breaker to the OFF position.
9	Operate the MAIN DISCONNECT switch to the OFF position.
10	Open gate valves V4 and V9. Close valve V3.
	B. Klystron Removal
11	Remove the eight bolts holding the klystron output flange to the waveguide adapter.
12	Open the horizontally hinged klystron enclosure door. Remove the connector clamps from the two klystron filament terminals.
13	Raise the center shield over the magnet assembly until it is held by its latch.
14	Unfasten the two knurled klystron assembly holding screws located on the pull-bar brackets. Pull the klystron assembly forward and down the supporting rails until it locks in its stop position. See Fig. 2.
15	Disconnect the coaxial cable from the klystron input terminal.
16	Retract the holding pin at the left side of the assembly and rotate the klystron assembly 180 degrees. The rotation is started by moving the cathode end of the klystron to the rear. Continue the rotation until the klystron's position is inverted and locked in place.
17	Disconnect the collector lead from the klystron.
18	Remove the two bolts used to lock the position of the tuning shaft supporting plate. Uncouple the tuning shafts from the four klystron tuner shafts by loosening the two Allen screws closest to the klystron body on each tuning shaft.
19	Loosen the bolts holding the two pairs of tube supports. Lift the support blocks and move the tube supports away from the center of the assembly.
	Caution: <i>The klystron should be lifted using one hand on the output waveguide section near the klystron body and the other hand on the cylindrical section below the radiation shield on the collector seal. Do not handle the klystron by its coolant fittings or ceramic sections.</i>
20	Lift the klystron, carefully guiding it through the magnet assembly, to remove it from the amplifier.
21	Store the klystron in the manufacturer's shipping carton.



A-OPERATING POSITION



B-EXTENDED POSITION

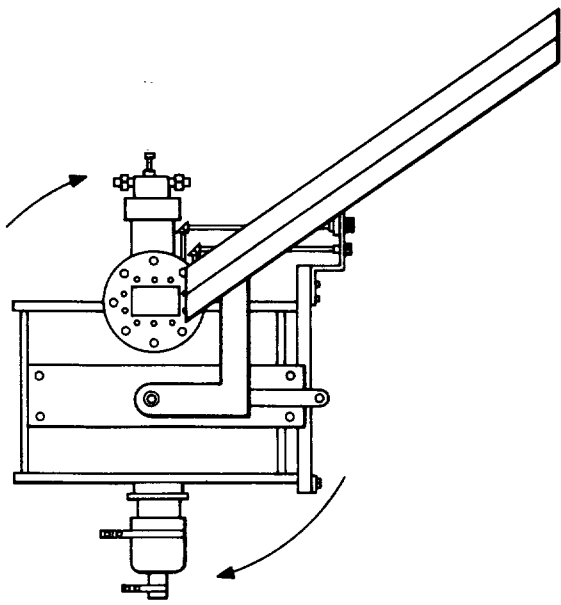

C-INVERTED (LOADING) POSITION

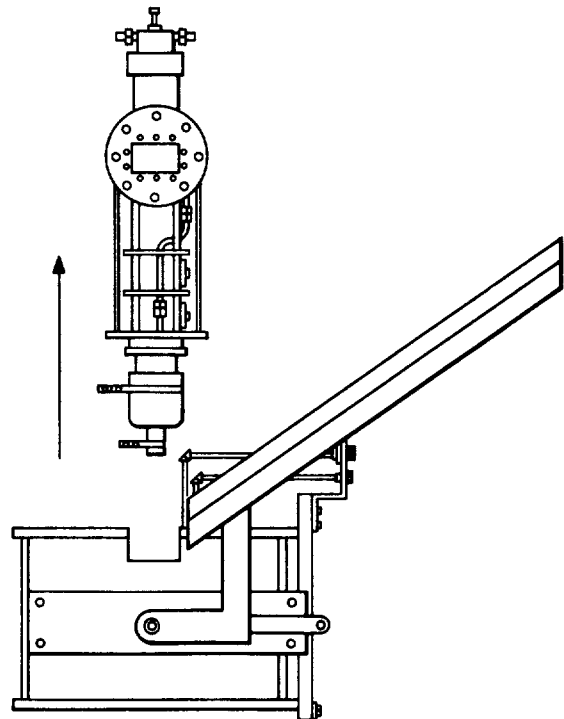

D-KLYSTRON REMOVAL

TPA 559698

Fig. 2—Klystron Assembly—Side View

CHART 1 (Cont)

STEP	PROCEDURE
	<p data-bbox="321 385 672 412">C. New Klystron Preparation</p> <p data-bbox="212 449 1468 540">22 Inspect the new klystron for obvious defects or damage. Verify that the ceramic portions of the tube are clean. If necessary, clean the ceramic sections using a mild detergent in water solution.</p> <p data-bbox="212 576 1468 704">23 Using the KS-14510 volt-ohm-milliammeter, verify that the radiation shield around the collector ceramic section is in contact with the klystron body and is insulated from the klystron collector. If necessary, remove the shield, noting the position of all pieces, and scrape the paint on the klystron body to allow electrical contact with the shield.</p> <p data-bbox="212 740 1468 832">24 Remove the silver-plated waveguide adapter at the output terminal of the klystron. The adapter in the power amplifier is used for the transition between the klystron output terminal and the power amplifier waveguide elbow.</p> <p data-bbox="212 868 1468 995">25 Using the graph in Fig. 3A, determine the klystron tuning mechanism approximate setting for the power amplifier operating frequency. Adjust each of the four klystron cavity tuning mechanisms to obtain the required indication. Record the indications for use in the klystron installation procedure.</p> <p data-bbox="321 1032 607 1059">D. Klystron Installation</p> <p data-bbox="212 1095 1468 1187">26 Insert the klystron, cathode end first, into the magnet assembly. Keeping the body of the tube vertical and centered, carefully lower the klystron through the magnet assembly until its mounting flange rests on the top surface of the magnet assembly.</p> <p data-bbox="212 1223 1468 1315">27 Move the two pairs of tube supports toward the center of the assembly and position the two support blocks into their tube support grooves. Tighten the support block bolts.</p> <p data-bbox="212 1351 841 1378">28 Connect the collector lead to the klystron.</p> <p data-bbox="212 1415 1468 1506">29 Retract the holding pin at the left side of the assembly and rotate the klystron assembly 180 degrees. The rotation is started by moving the collector end of the klystron forward. Continue the rotation until the klystron locks in position with the cathode end up.</p> <p data-bbox="212 1542 1084 1570">30 Connect the coaxial cable used at the klystron input terminal.</p> <p data-bbox="212 1606 1468 1734">31 Adjust each of the four CAVITY TUNING CONTROLS to obtain a counter indication which is the product of the associated klystron tuning mechanism indication recorded in Step 25 multiplied by 1200. Use the graph in Fig. 3B to determine the counter indication for each tuning control.</p> <p data-bbox="212 1770 1468 1862">32 Engage each of the four amplifier tuning control shafts in the klystron tuning mechanism shaft slots. Tighten the four Allen screws in each coupler.</p> <p data-bbox="212 1898 1468 1989">33 Tighten the tuning shaft support plate bolts with the support plate in a position which permits smooth control and shaft rotation.</p>

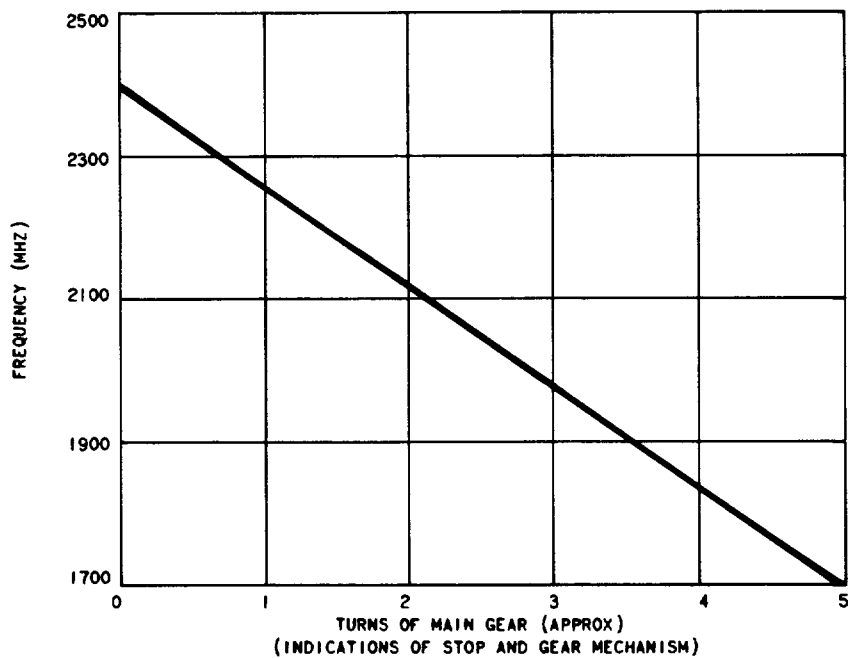

A - KLYSTRON TUNING MECHANISM ADJUSTMENT



B - RELATION OF KLYSTRON TUNING CONTROL AND AMPLIFIER TUNING CONTROL ADJUSTMENTS

TPA 559699

Fig. 3—Klystron Tuning Charts

CHART 1 (Cont)

STEP	PROCEDURE
34	Disconnect the vertical flexible waveguide section from the top flange of the output reflectometer, E20.
35	Loosen the bolts holding the output waveguide band brackets to permit movement of the waveguide band and reflectometer assembly in all directions.
36	Verify that the hinged center shield of the protective grill over the klystron is opened and held against its magnetic latch.
37	Depress the latch in the right klystron assembly supporting rail and push the klystron assembly toward the rear and upward until it is in place in its operating position. Fasten the two knurled klystron assembly holding screws located on the pull-bar brackets.
38	Adjust the output waveguide bend position to align the waveguide adapter with the klystron output flange. Insert and tighten the eight bolts, making certain any movement is that of the waveguide bend and reflectometer assembly and not of the klystron.
39	Connect the vertical flexible waveguide section to the top flange of the output reflectometer.
40	Attach the filament lead connectors to the two klystron filament terminals.
41	Connect all hoses to the klystron and magnet assembly.
42	Close the hinged center shield of the protective grill and the horizontally hinged klystron enclosure door.
43	Perform the klystron cooling system tests and klystron alignment described in Section 403-405-501.