

DROPS FROM OPEN AND RURAL LINES

1. GENERAL

1.01 This section covers methods of bridling to open wire and installing 105A wire terminal at intermediate and dead-end poles.

2. DISTRIBUTING DROPS FROM OPEN WIRE LINES

2.02 Distribute drops from a drive hook in the pole if climbing space, joint use, and ground clearances permit, and there is adequate clearance between the drops and existing or future open wires. Otherwise distribute drops from crossarms as outlines in 2.02.

2.02 Distribute drops from crossarms as follows:

(a) **Crossarms Other Than DE Type:** Distribute from a drop wire hook where not more than two drops will be run from the same point on the crossarm. Distribute from a guard arm hook where more than two drops will be run. Not more than five drops shall be attached to one guard arm hook.

(b) **DE Crossarm:** Distribute drops from drop wire hooks attached to the sides of the crossarm.

3. INSTALLING DROP WIRE AND GUARD ARM HOOKS ON CROSSARMS

3.01 Attach drop wire hook to crossarm with a 1-1/2 inch No. 18 RH galvanized wood screws. On a crossarm equipped with insulator pins, center the hook on side of crossarm and between pins as covered in 4.10 or closer to the pole if adequate clearances can be obtained and climbing space is not obstructed. On a crossarm on which the open wires are terminated on deadend brackets, locate the hook midway between the two outer bracket positions and 1-1/8 inches above bottom of crossarm. Shift location of hook as necessary to avoid checks or cracks in crossarm. Drill lead hole for the No. 18 wood screw with an 11/64-inch drill point.

3.02 Place guard arm hook in a 9/16- or 5/8-inch clearance hole drilled in the side of the crossarm (3-1/4 inches thick). Center the hole between top and bottom of the arm and between pins or closer to the pole if adequate clearances can be obtained and climbing space is not obstructed.

4. WIRING AT CROSSARMS AND POLES

4.01 Terminate parallel drop wire at a 101B wire terminal and run twisted pair wire between the terminal and the open wire.

4.02 If the drop is run with HD wire, the 101B wire terminal is not required, as this wire may be connected directly to the open wire.

4.03 Locate the 101B terminal on pole side of crossarm with lower edge 3/4 inch above bottom of crossarm. Locate the first terminal to be placed between the first and second wires from the pole so that it will be readily accessible. Space additional terminals 2-1/2 inches apart on DE crossarms and 3-1/2 inches apart on other crossarms.

Note: To avoid splicing out parallel drop wires installed prior to placing the 101B terminal or to comply with distances specified in Part 7, the terminal may be located between any pin position.

4.04 The binding posts of the 101B terminal will accommodate three parallel drop wires and the bridle wire to the open wire.

4.05 Terminate twisted pair wire under the bottom washers on the binding posts, and the first parallel drop wire between the second and third washers and so on.

4.06 If four drops wires are to be bridged to the same open wire, install two 101B terminals and bridle from each terminal to separate bridging sleeves or bridging connectors spaced approximately 2 inches apart on the open wire.

4.07 Install 5/8-inch drive rings on underside of crossarm near the point where the drop is attached and at points where wires extend to the open wire at the 101B terminals. Install additional rings as required to limit ring spacings to approximately 20 inches.

4.08 Use B bridle wire for bridling between 101B terminals and open wire except where the use of D or E block wire is specified as in Part 7 or by local instructions. Use bridging sleeves or bridging connectors for connection to open wire.

4.09 At double crossarms equipped with insulator pins follow the general wiring method specified for single crossarms, locating the 101B terminal preferably on the side of the crossarm toward the bridging sleeves or bridging connectors. Locate the wire run on the underside of the same crossarm.

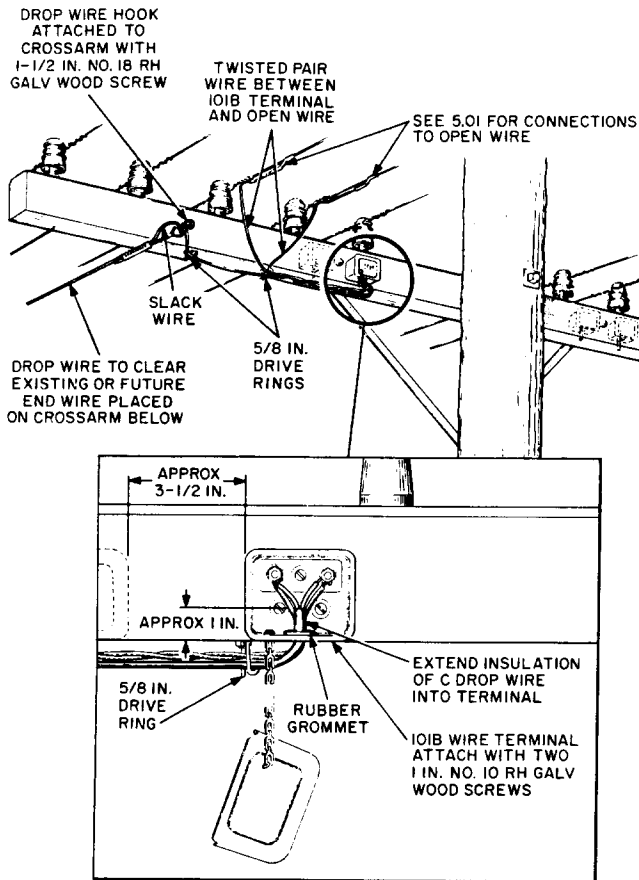

Fig. 1—Where Drop Wire is Distributed From Crossarms Other Than DE-Type

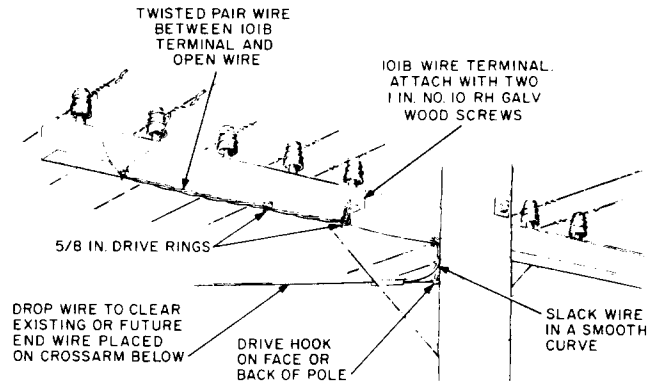

Fig. 2—Where Drop Wire is Distributed From a Pole

Crossarms Equipped with Insulator Pins

4.10 The wiring arrangement on crossarms equipped with insulator pins is shown in Fig. 1 and 2.

4.11 Crossarms equipped with deadend brackets (Fig. 3).

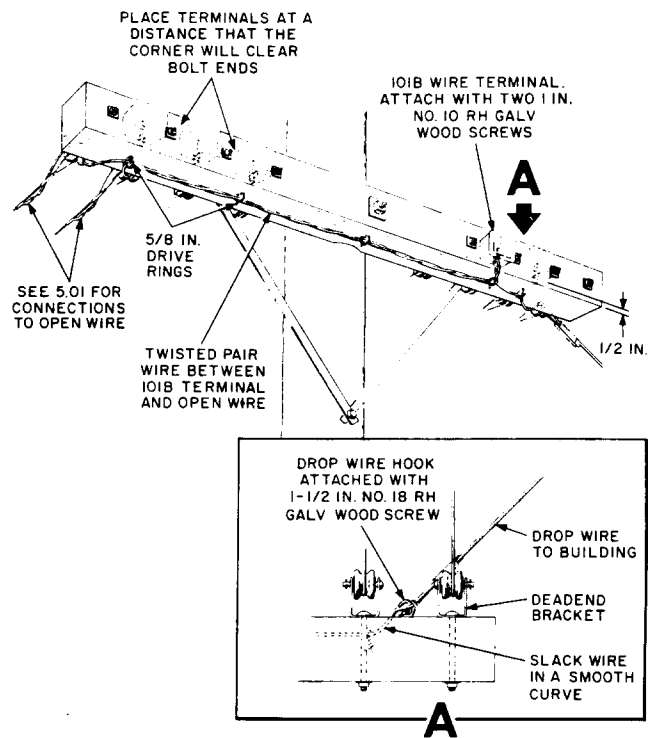

Fig. 3—Wiring Arrangement on DE Crossarms not Having Back Braces

4.12 The wiring arrangement on DE crossarms equipped with back braces is shown in Fig. 4.

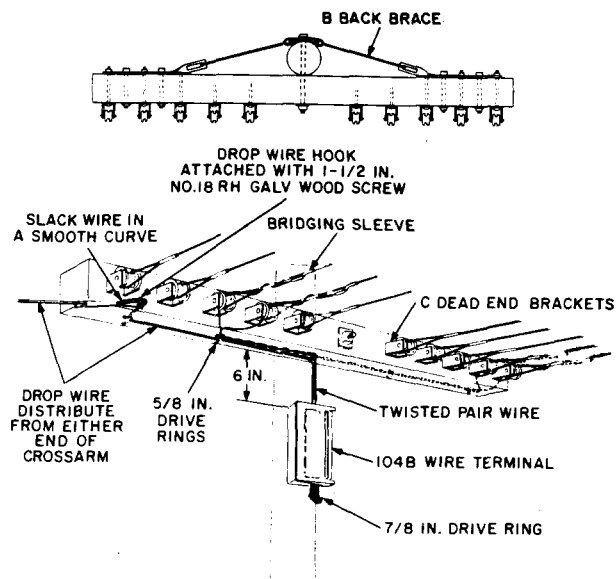

Fig. 4—For More Than Two Drops Use a 104B Wire Terminal Mounted on Pole

4.13 At double crossarms equipped with deadend brackets, follow the general wiring method as shown in Fig. 3, locating the 101B terminal on the outer side of the crossarm not equipped with deadend brackets. Locate the wire run on the underside of the same crossarm.

Poles Equipped with Wooden Pole Brackets

4.14 The wiring arrangements on line poles equipped with wooden pole brackets are shown in Fig. 5.

4.15 Poles equipped with deadend brackets (Fig. 6).

5. CONNECTING TWISTED PAIR WIRE TO OPEN WIRE

5.01 In general, connect twisted pair wire to open wire attached to glass insulators or deadend brackets. As an alternate, bridging connectors may be used in lieu of bridging sleeves. However, in localities where corrosion of the bridle wire occurs adjacent to the bridging connector, connect to open wire as covered in 5.02 or 5.03 depending on the severity of corrosion.

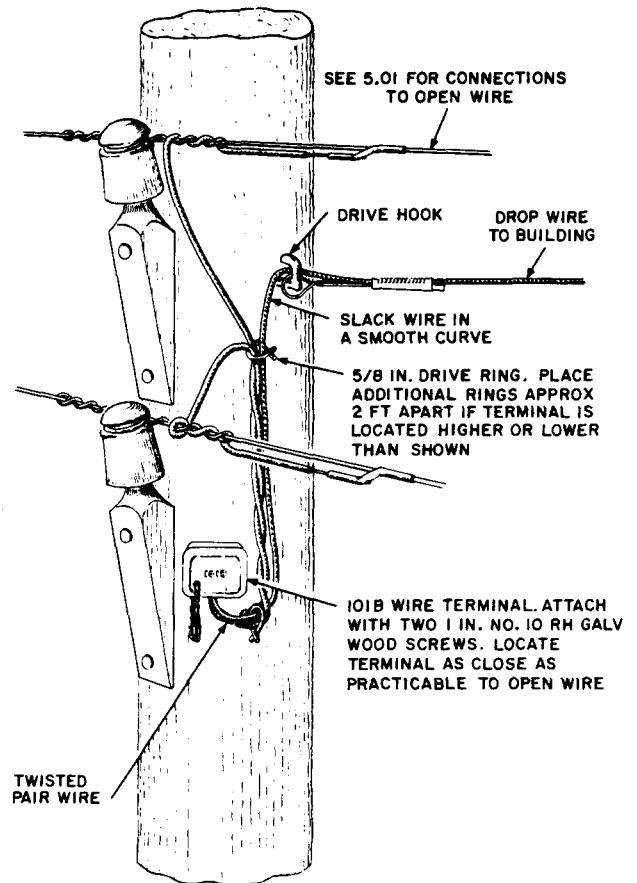

Fig. 5—Where Pole Brackets are Located on Same Side of Pole

5.02 Where corrosion of the bridle wire occurs between the end of the conductor insulation and the bridging connector, provide a bypass in making the connection to the open wire as covered below. For the more severe corrosive conditions, follow the method outlined in 5.03.

- (1) Provide a sufficient length of twisted pair wire to extend from the 101B terminal to approximately 8 inches beyond the bridging connectors.
- (2) Remove the insulation for approximately 8 inches from each bridle conductor at the open wire end.
- (3) Thoroughly clean the conductors for approximately 2 inches beyond the end of the insulation.

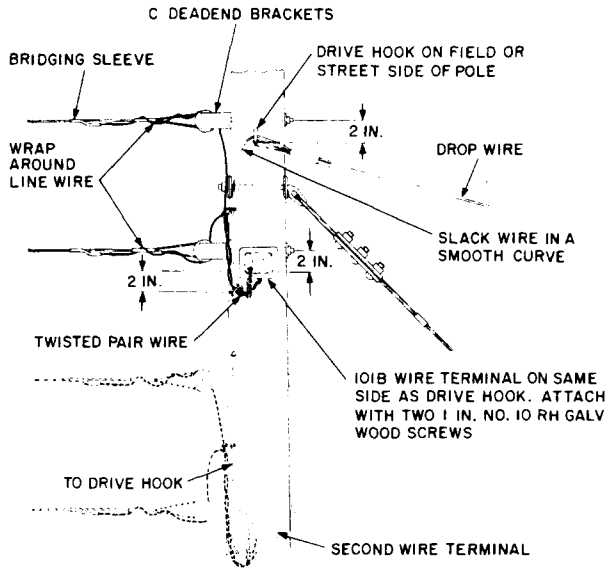

Fig. 6—Where Lines are Terminated on Deadend Brackets Attached to Face or Back of a Pole

- (4) Extend bridle wire directly from last drive ring to bridging connectors without making any wraps around the line wire.
- (5) Connect each conductor at the open wire by means of a bridging connector installed with the bolt in a horizontal position and extend the excess length of bare conductor back on the insulated portion in spiral wraps as shown in Fig. 7 and 8.

5.03 Where exposure conditions are so severe that the bypass method covered in 5.02 does not provide sufficient permanence because of rapid corrosion of the spiral wrap, a more durable bypass may be provided as follows:

- (1) Provide a sufficient length of twisted pair wire to extend from the 101B terminal to the bridging connectors.
- (2) Extend bridle wire directly from last drive ring to bridging connectors without making any wraps around the line wire, and connect each conductor to bridging connector installed with the bolt in a horizontal position.
- (3) Starting approximately 4 inches from bridging connector, make at least four spiral wraps of a half-length of 19-inch 080

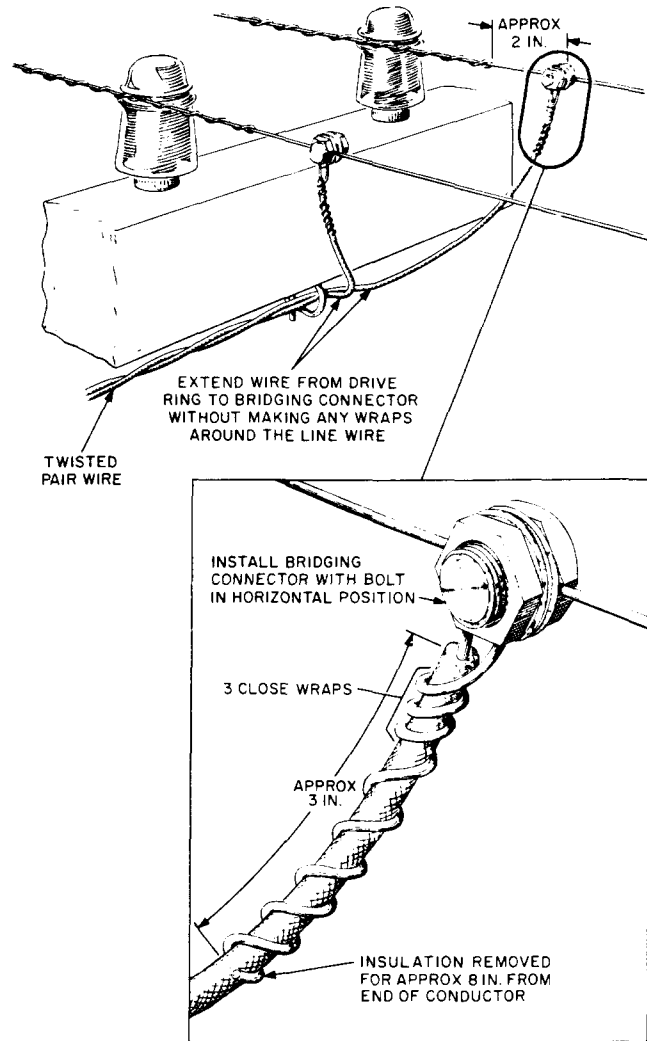

Fig. 7—Where Line Wires are Tied to Pin-Type Insulators

or 104 copper tie wire around each bridle conductor in the direction toward the bridging connector. The last wrap shall be close to the end of the rubber insulation but shall not make contact with the bare conductor.

- (4) Extend tie wire to an additional bridging connector.

5.04 Where corrosion of bridle wire occurs between end of conductor insulation and a bridging sleeve, provide a bypass in the manner described in 5.03 using a bridging connector for attaching the tie wire to the line wire.

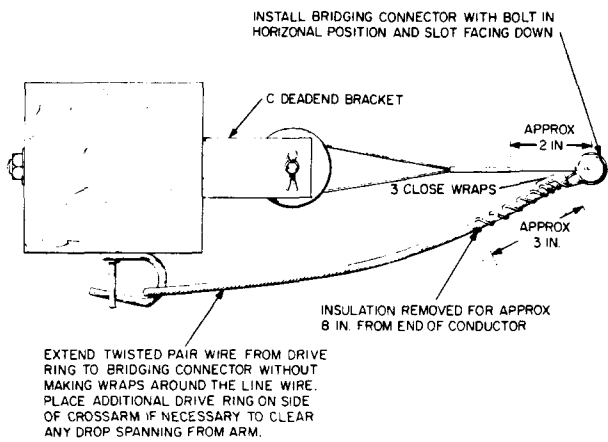

Fig. 8—Where Line Wire are Terminated on Deadend Brackets

5.05 Connect bridle wire to tree wire, using one of the methods covered for bare line wire, depending on the exposure conditions involved. Remove sufficient insulation from the tree wire to permit making the connection as specified for bare line wire.

6. INSTALLATION OF WIRE VIBRATION DAMPER

6.01 Install vibration dampers as covered in Section 623-030-103 where upon wires vibrate to such an extent as to cause breakage of twisted pair wires at bridging points or to produce a vibration noise at a building to which a drop wire is attached.

7. BRIDLING WHEN FUSELESS PROTECTORS ARE USED AT STATION

7.01 Where stations served from open wire or rural wire will use the fuseless protector, 123A1A or 128A1A-2, a length of D or E block wire not less than 2 feet shall be used between the drop wire and open or rural wire. Bridging to 109 size steel wire or 104 size copper steel wire may be made with bridging connectors or a combination of a 109 by 109B aluminum bridging sleeve and an 034 H splice sleeve.

8. INSTALLATION OF 105A WIRE TERMINAL ON INTERMEDIATE POLES

8.01 Locate wire terminal approximately 12-inches from pole. Remove binder from multiple line wire run and place 5 wraps of D vinyl tape.

Grip conductors with both hands, and twist against the lay of wire until conductors are loose and parallel to the support wire.

8.02 Insert wire wedges so that support wire is separated from the conductors and locate pin to be terminated (Fig. 9).

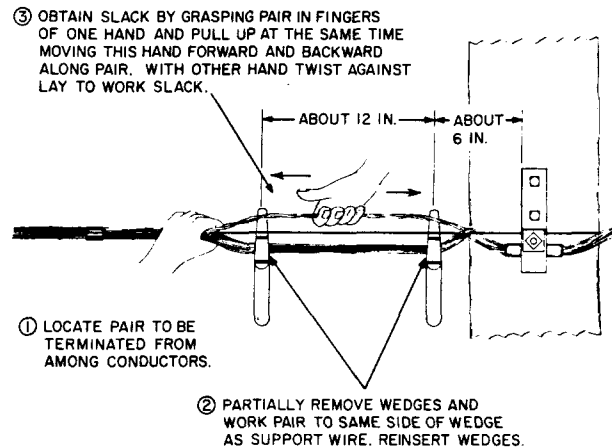

Fig. 9—Locating Wire Pair

8.03 Attach 105A wire terminal (Fig. 10) to wire pin and secure to support wire as shown in Fig. 11.

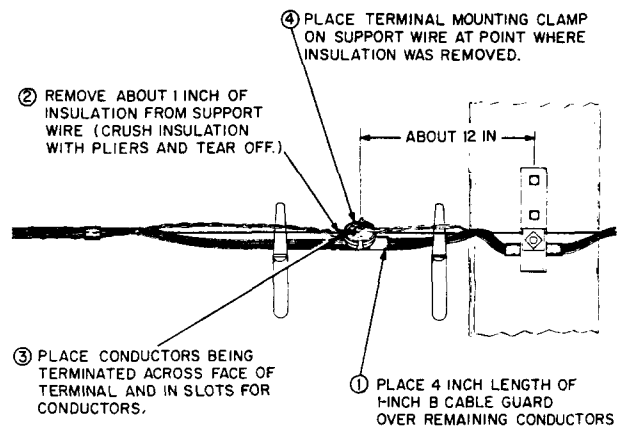

Fig. 10—Attaching 105A Wire Terminal

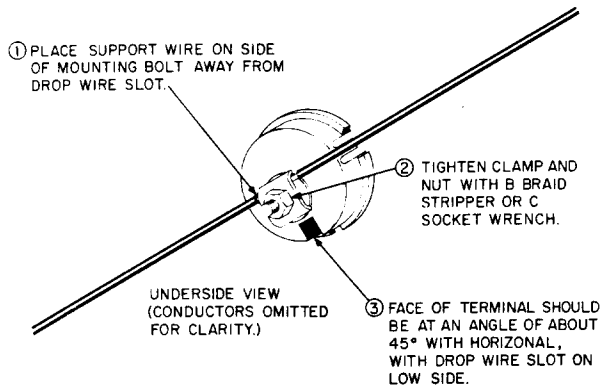

Fig. 11—Attaching Support Wire

8.04 Dress wire conductors and drop wire into slots provided in wire terminal. Secure leads to binding posts as shown in Fig. 12.

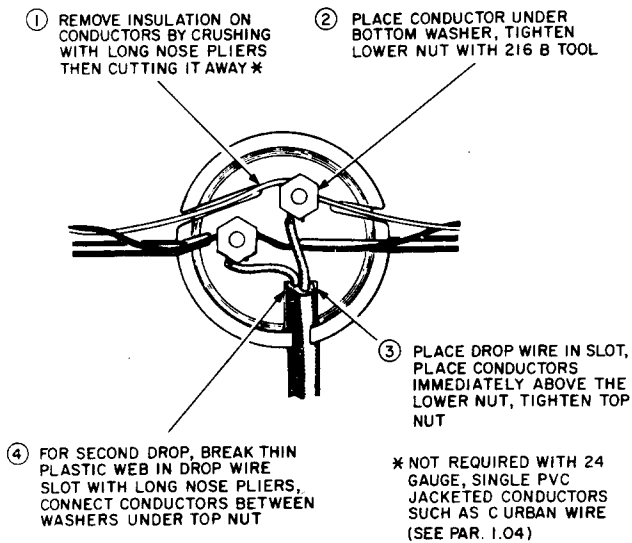

Fig. 12—Terminating Wire Leads

8.05 Replace cover on wire terminal and dress pole attachments as shown in Fig. 13.

8.06 A maximum of three wire terminals can be mounted on each side of the wire bracket. A complete installation is shown in Fig. 14, although individual terminals are added only as needed.

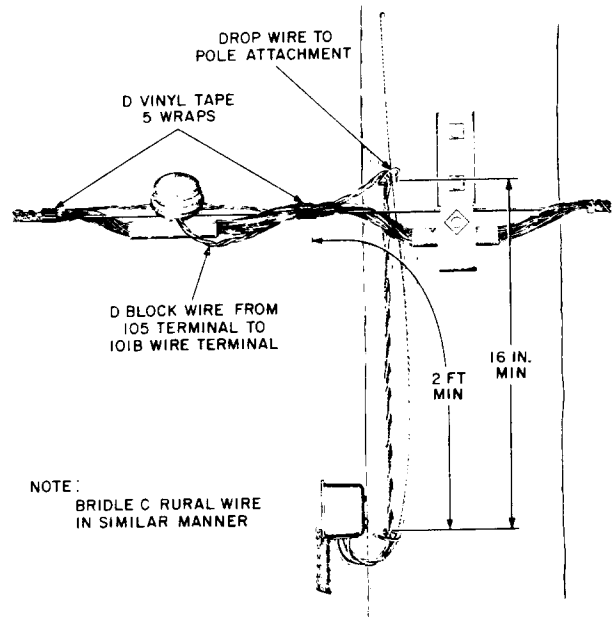

Fig. 13—Pole Attachment of Block and Rural Wire

The order of installation would depend on the direction of feed for the drop wires.

9. INSTALLATION OF 105A WIRE TERMINAL AT DEAD-END POLES

9.01 Fig. 15 shows multiple line wires terminated at dead-end pole.

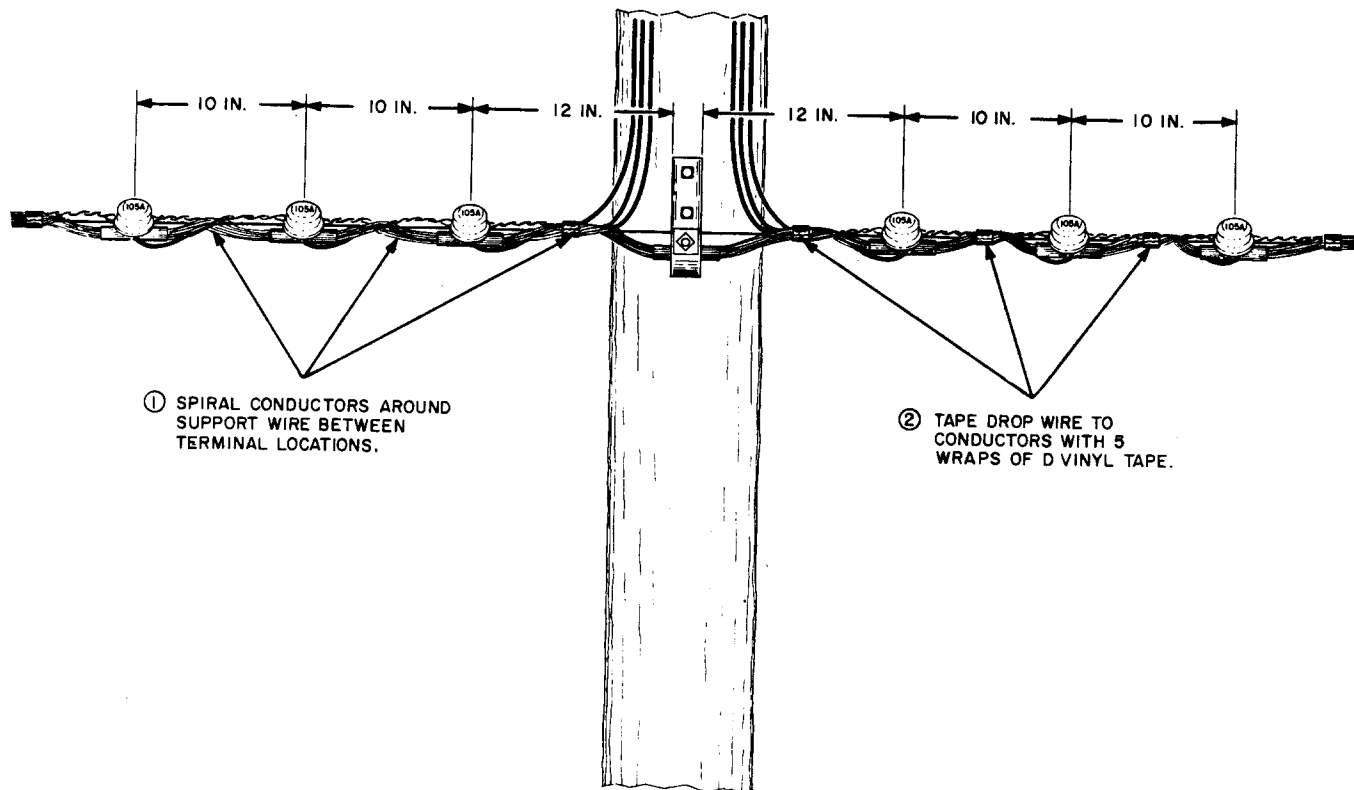

Fig. 14—Arrangement of Wire Terminals

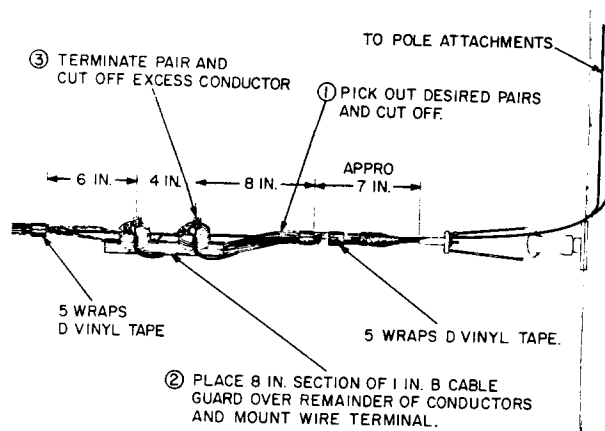

Fig. 15—Location of Wire Terminals at Dead-End Pole