

CONNECTING BLOCKS AND TERMINALS

CROSS CONNECTING AND WIRING

1.00 INTRODUCTION

This section covers method of cross-connecting cable pairs in inside cable terminal boxes. General wiring arrangements are discussed and illustrated for the following:

- G- and H-type cable terminal boxes.
- Customer-provided cabinets.
- Binding post strapping.
- Frame-type terminals.
- L-type fuse chamber and terminal box.
- 1A1 and 2.41 cable terminal sections.
- Fuseless-protected 1A3A and 1A4A cable terminal blocks.
- 14A fuse holder.

2.00 GENERAL

2.01 The general wiring principles covered here-in may also be used in wiring the older types of inside wiring terminals.

2.02 The amount of slack in cross-connecting wires is generally satisfactory if the wire is long enough to reach the pair of binding posts beyond that on which it is to be terminated.

2.03 Where frequent movement of station wires is anticipated, consideration should be given to their permanent termination on a connecting block. Cross connections may then be run from the connecting block to the cable terminal block.

- B cross-connecting wire should be used for making cross connections.



Special Service Protection (SSP) must be provided at cable terminals containing special circuit appearances.

3.00 GA-, GB-, AND HS-TYPE INSIDE WIRING TERMINALS

Station wiring at the GA-, GB-, and HS-type inside wiring terminals is shown in Fig. 1, 2, and 3.

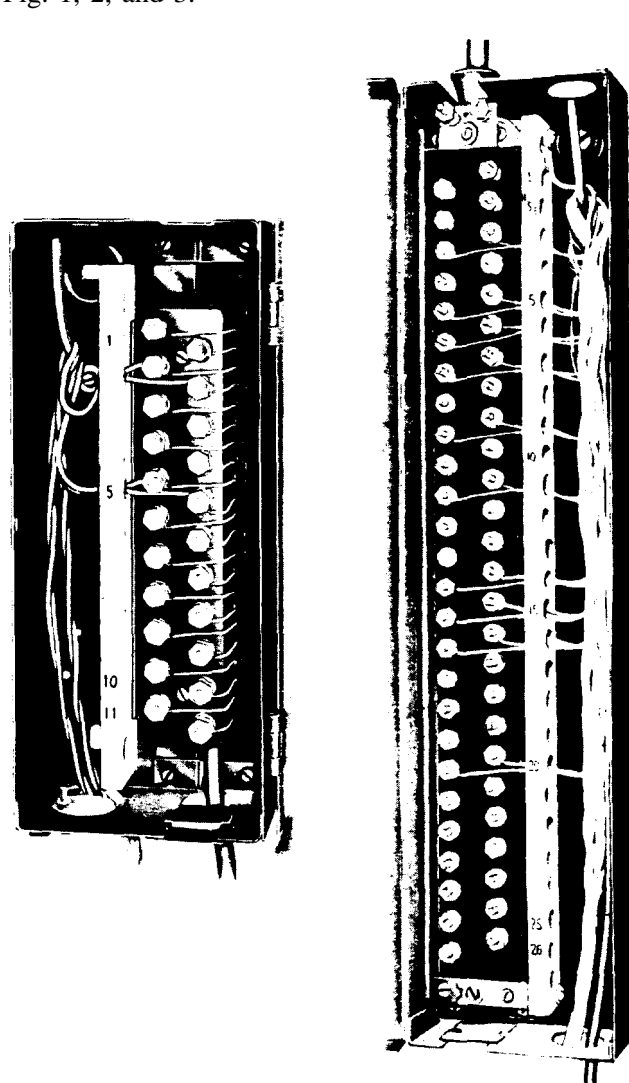

Fig. 1 -Station Wiring of GA-type Terminal

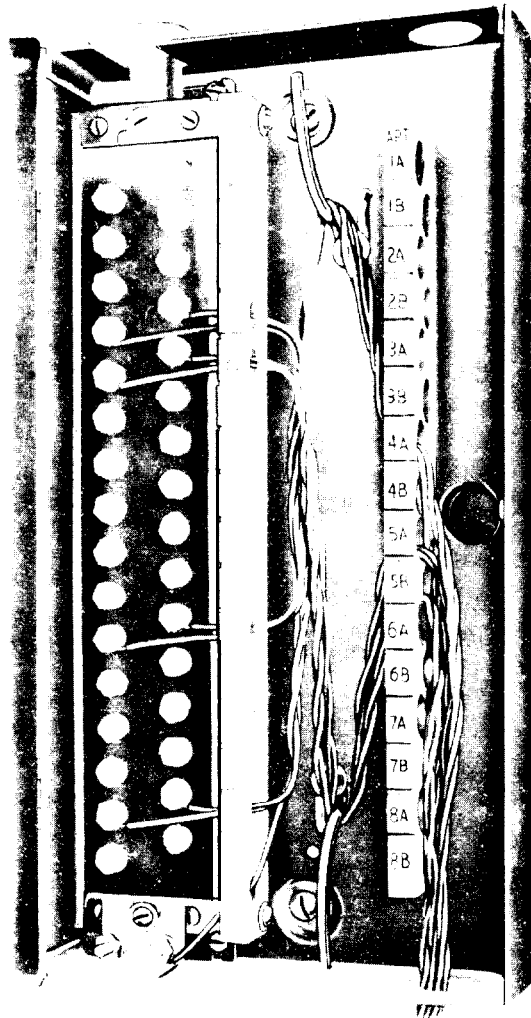

Fig. 2 -Station Wiring of GE-type Terminal

4.00 GC-TYPE INSIDE WIRING TERMINALS

Station wiring and cross connections at a GC-type inside wiring terminal are shown in Fig. 3. Position of binding post chamber and 30- or 31-type connecting block may be reversed, or terminal may house two binding post chambers or two connecting blocks instead of arrangement shown.

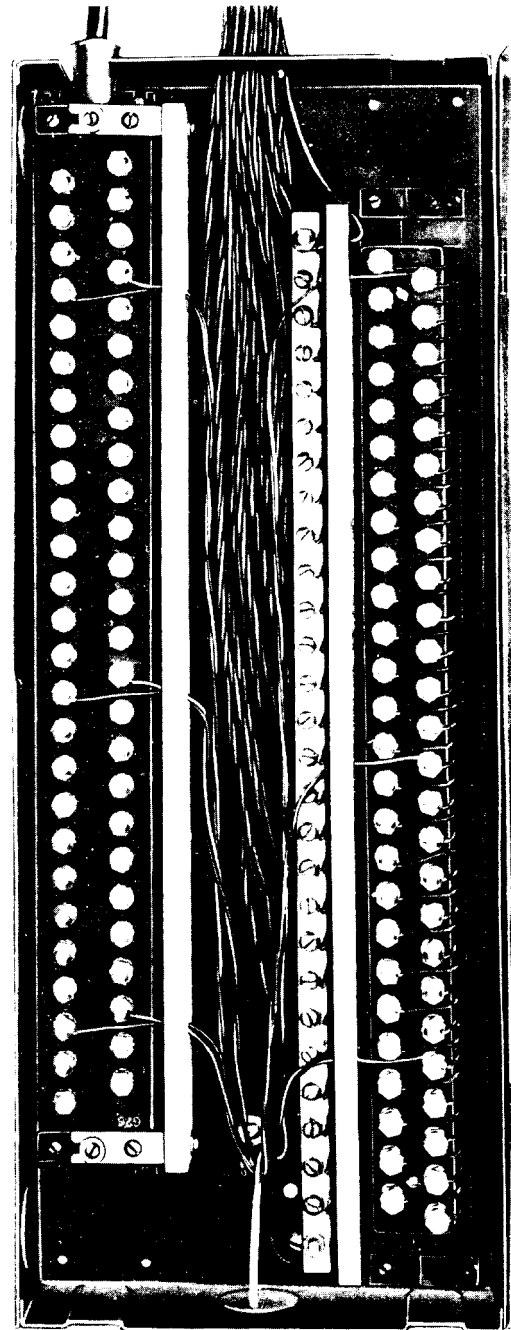

Fig. 4 -Station Wiring and Cross Connection of GC-type Terminal

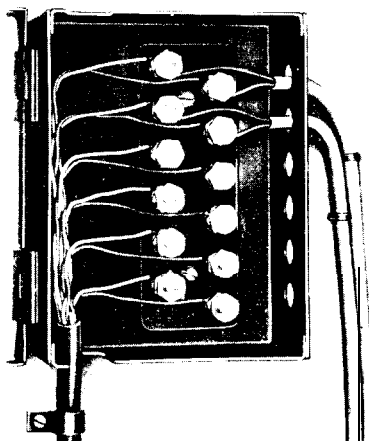

Fig. 3 - Station Wiring of HS-type Terminal

5.00 CUSTOMER-PROVIDED WIRING CABINETS

When a customer-provided wiring cabinet is used instead of a cable terminal box, arrange wiring similar to cabinet shown in Fig. 5.

6.00 BINDING POST STRAPPING

6.01 The L bonding ribbon is a notched-spring brass strip used for strapping binding posts

on 3 J-inch centres, and accommodates 14 binding posts, approximately 10 inches in length, as shown in Fig. 6.

6.02 The S bonding ribbon consists of a notched-spring brass strip fastened to a fiber insulating strip used for strapping binding posts on 5 X-inch centers (G and H binding post chambers, 30-type connecting blocks). It accommodates 16 binding posts, approximately 10 inches in length. Mount as shown in Fig. 7.

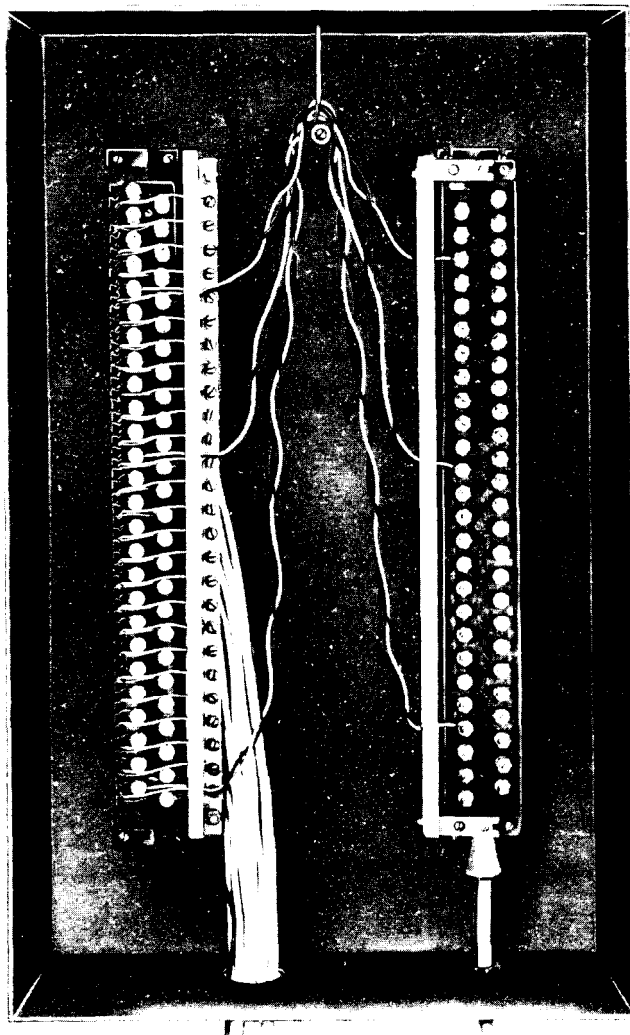

Fig. 5 -Typical Wiring of Customer-provided Cabinet



Fig. 6-L-type Bonding Ribbon

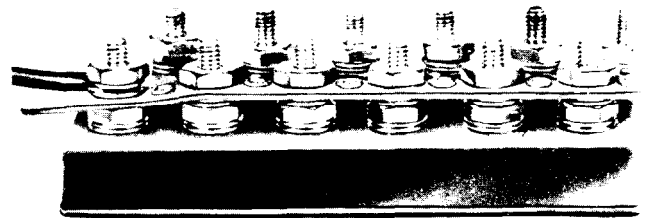

Fig. 7 — S-type Bonding Ribbon

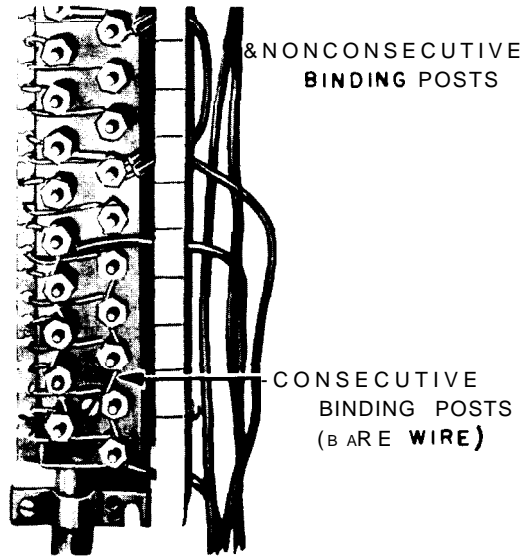

Fig. 8 — Use of Wire in Strapping Binding Posts

6.03 Wire may be used to strap binding posts as shown in Fig. 8. The same type wire used in the wiring of the terminal is suitable for strapping binding posts.

7.00 FRAME-TYPE INSIDE WIRING TERMINALS

7.01 Place cross connections on frame-type inside wiring terminals as shown in Fig. 9. This shows a typical arrangement of cross connections on a double-sided frame. Cross connections on single-sided frames are the same as the cross connections between binding posts on the same side of a double-sided frame.

7.02 **Cross-connecting Wires** — Divide frame visually into upper and lower halves.

- Cross connections originating in upper half of frame should be run to top of frame.
- Cross connections originating in lower half of frame should be run to bottom of frame.
- Cross connections running from one side of a double-sided frame to the opposite side should pass directly through frame, and then through distributing rings on opposite side of the frame to point of termination.
- Cross connections originating and terminating through the same fanning strip should run through the nearest top or bottom distributing ring.
- Cross connections running to the opposite side of the frame should pass behind vertical cross connections.

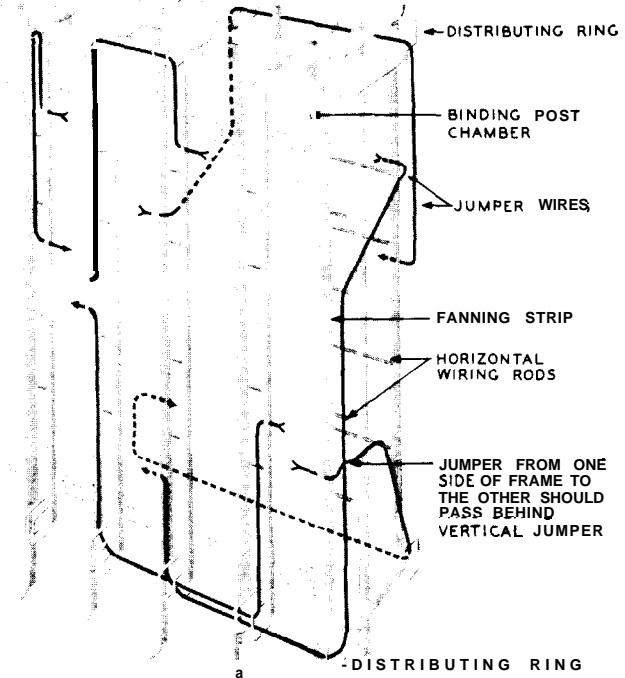

Fig. 9 — Cross-connection Arrangement on a Frame-type Terminal

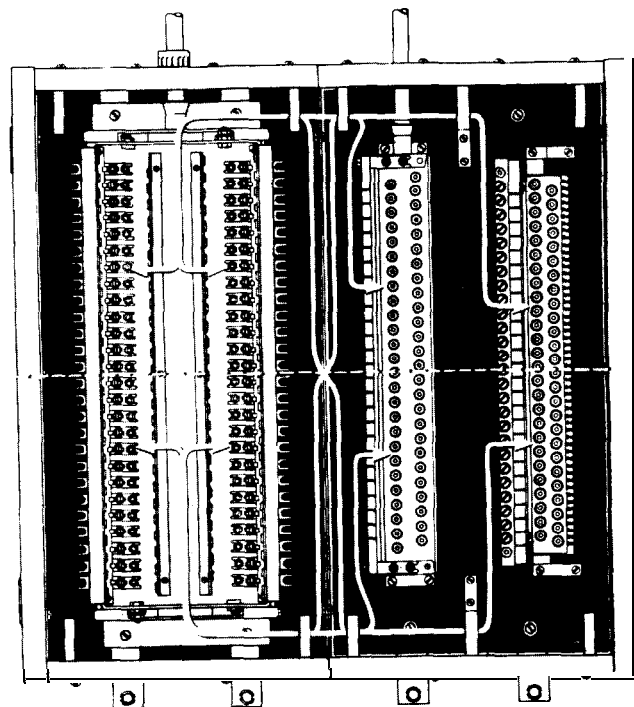

Fig. 10 — Typical Wiring Arrangement in LA-type Terminal

8.00 FUSE-TYPE PROTECTED TERMINALS (LA, LB, AND LC)

8.01 The LA-type terminal is equipped with an LA-type fuse chamber. Space is provided for mounting binding post chambers or connecting blocks as shown in Fig. 10. Station wiring is terminated normally on the binding post chamber or on the connecting block. Cross connections must be run to the LA-type fuse chamber.

8.02 The LB-type terminal is equipped with an LB-type fuse chamber in which both feeder

and house cables are permanently terminated. The fuses provide the cross connections between feeder and house cable pairs.

8.03 The LC-type terminal is equipped with an LX-type fuse chamber. No space is provided for binding post chamber or connecting block within the terminal. Station wires may be terminated on the binding posts of the fuse chamber shown in Fig. 11. Place 60-type fuses as specified in the section entitled Protection and Fusing of PBX Trunks, Tie Trunks, Ringing and Battery Feeders, and Off-premises Extensions

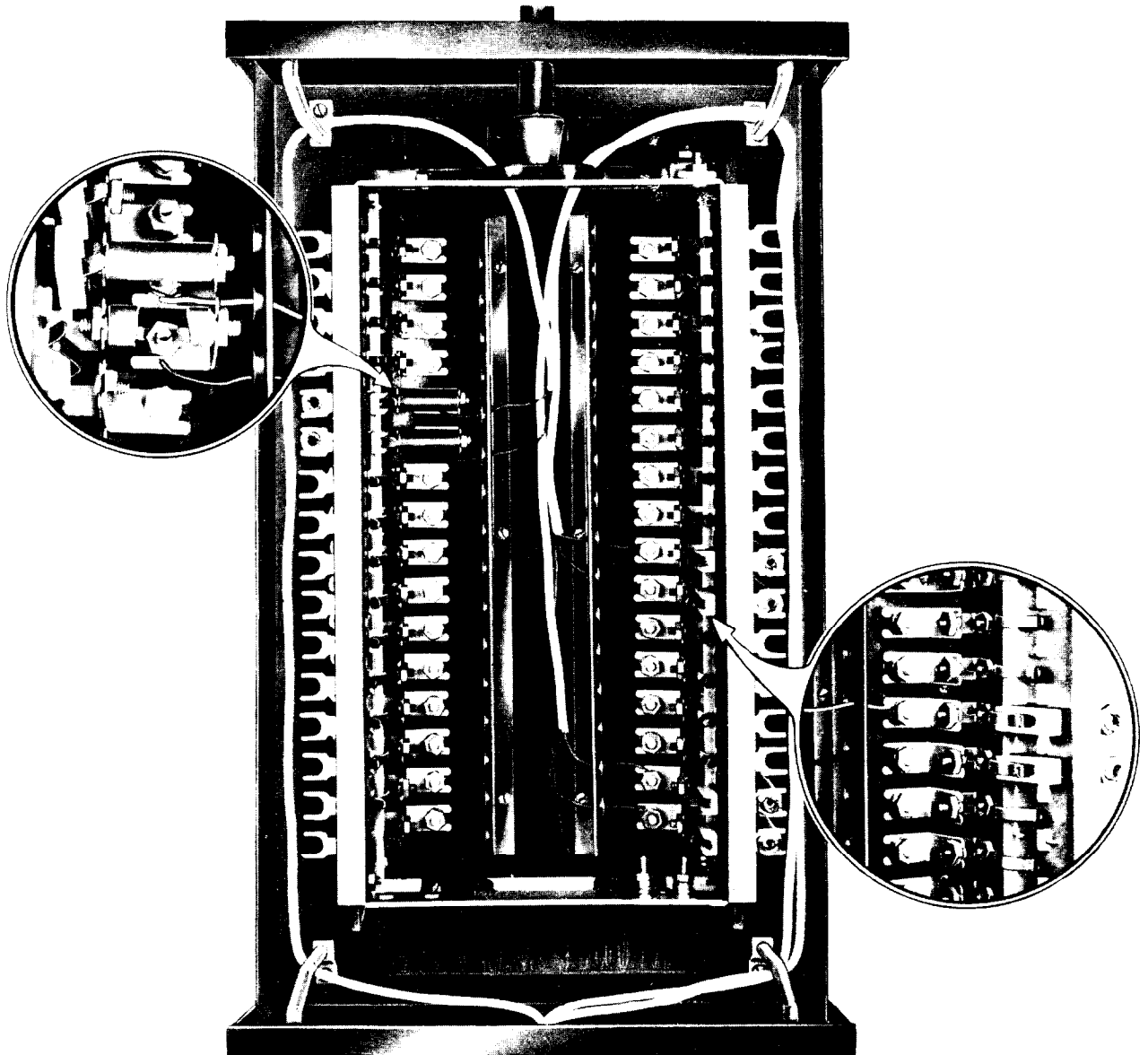

Fig. 11 -Typical Station Wiring of LC-type Terminal

8.04 House cable pairs are not terminated in LA-type fuse chambers. They are terminated in a separate binding post chamber or connecting block shown in Fig. 10.

- Feeder cable pairs are designated F or FDR.
- Feeder cable pairs placed in service must be equipped with 7A fuses and No. 26 and 27 protector blocks.

8.05 The 2-piece clip for mounting the 60-type fuse on the front of LA- and LB-type fuse chambers is joined by a P-290225 connector as shown on the right in Fig. 11 and 12. When a

60-type fuse is used, the connector is removed and stored in the bottom of side panel. The portion of the clip which is toward the center of the chamber should be removed from the binding post and re-installed to form a mounting for the fuse as shown on the left in Fig. 11 and 12.

8.06 Ground strips are installed as covered in the section entitled Connecting Blocks 30 Type Equipping, Wiring, and Terminating.

- No. 14 ground wire should be used to connect the 4-type ground strip to the P-290225 connector on the ground strip of the LA-type fuse chamber.

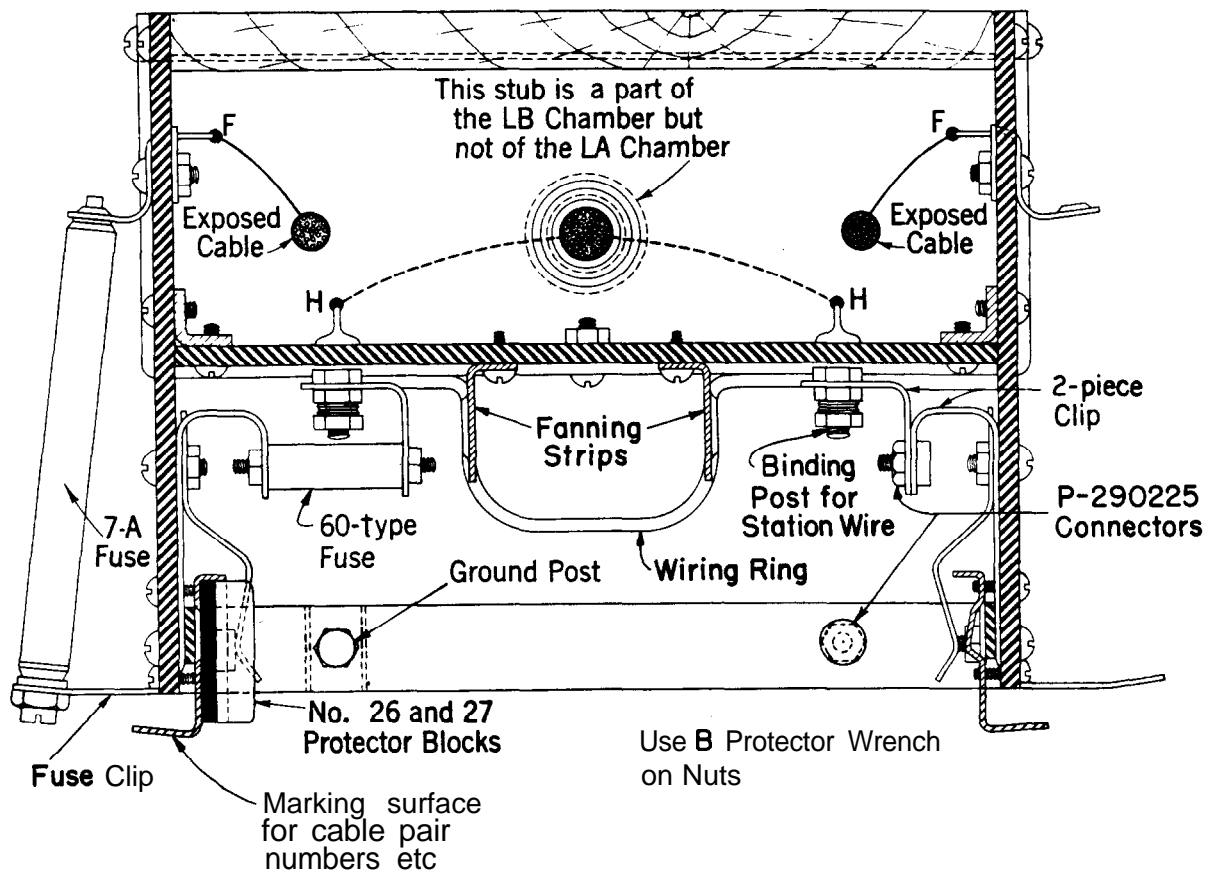

Fig. 12 -Cross-sectional View of LA- or LB-type Fuse Chamber

9.00 FUSELESS-TYPE PROTECTED TERMINALS

9.01 Terminal blocks 1A3A and 1A4A, identical in appearance, are similar to the NH-type cable terminal. Fig. 13 and 14 show protected terminal block 1A4A-26 wiring arrangement when mounted in 1A1 and 2A1 terminal sections.

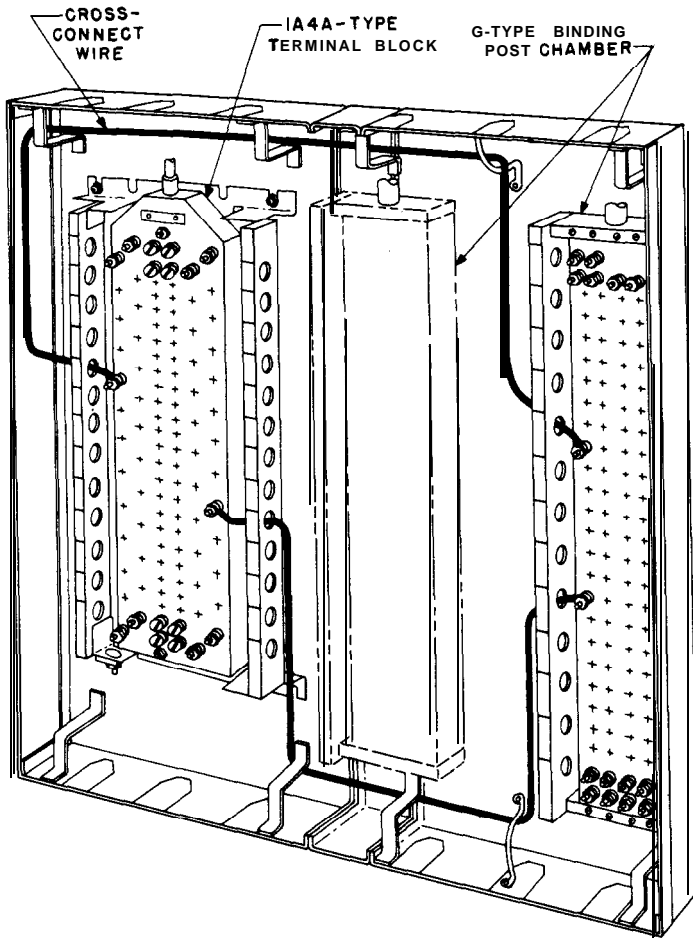

Fig. 13 -Cross Connecting in Fuseless-type Protected Terminals

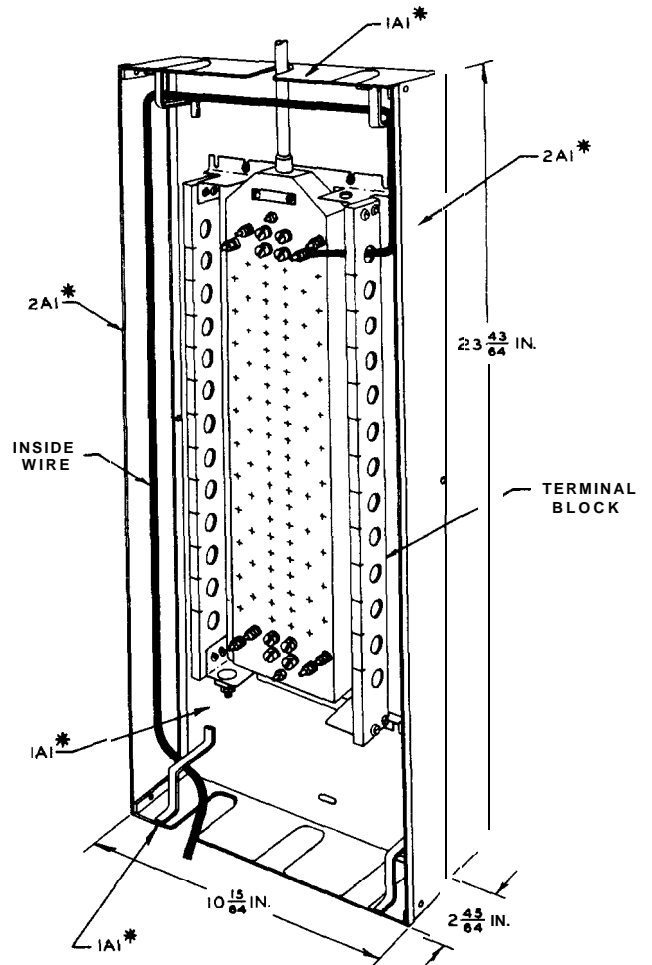

Fig. 14 -Station Wiring in Fuseless-type Protected Terminals

* TERMINAL SECTION

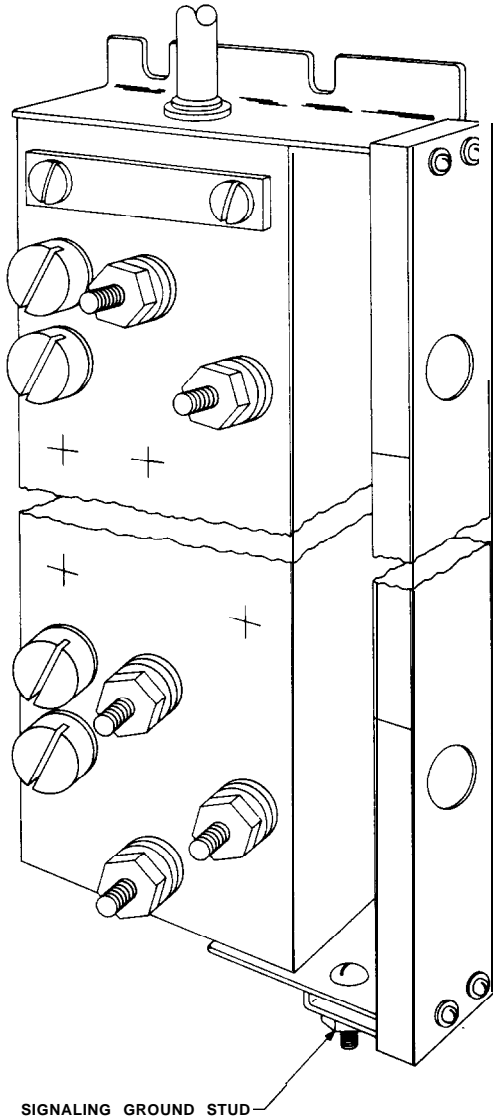

Fig. 15 -The 1A4A Terminal Block Showing Signaling Ground Stud

9.02 Signaling grounds on 1A4A (10-, 16-, and 26-pair terminal blocks) may be obtained from ground screw on fanning strip bracket shown in the lower right-hand corner of Fig. 15. Three additional ground lugs are provided on 51-pair terminal block, see Fig. 16.

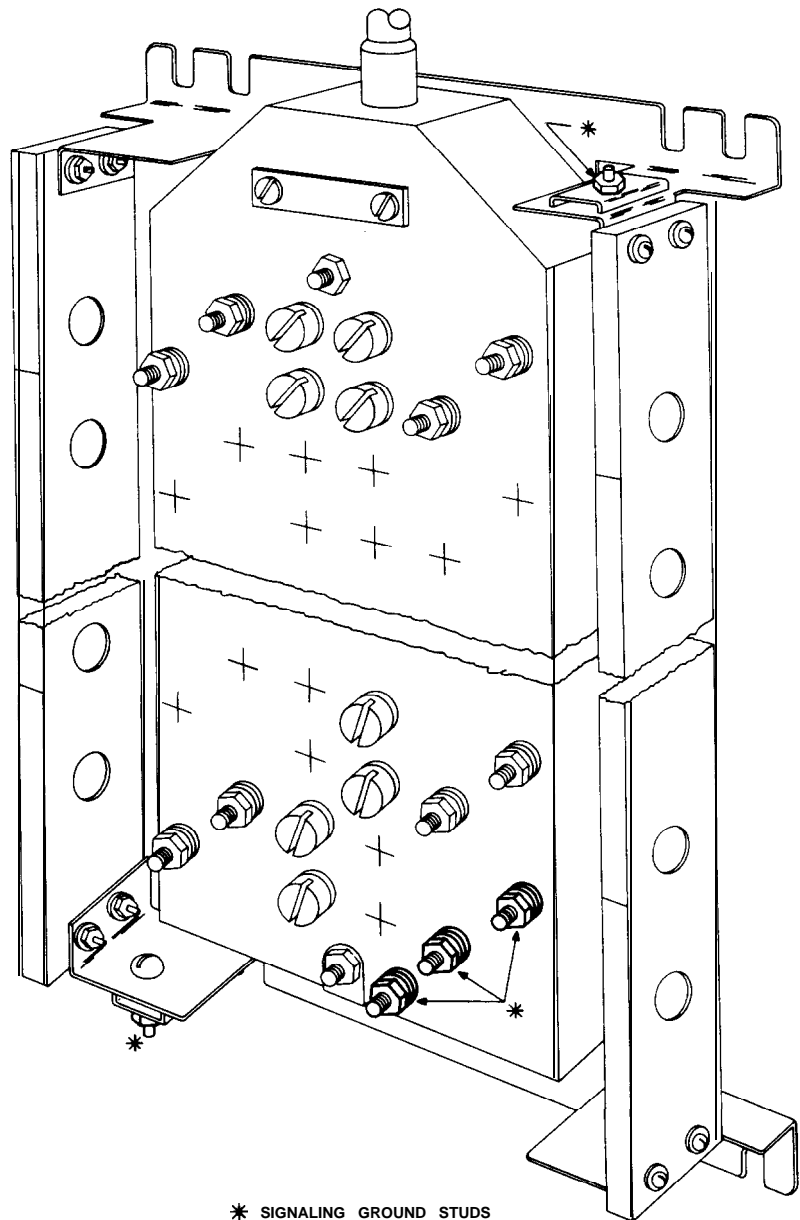

Fig. 16 -The 1 A4A-51 Cable Terminal ▶

* SIGNALING GROUND STUDS

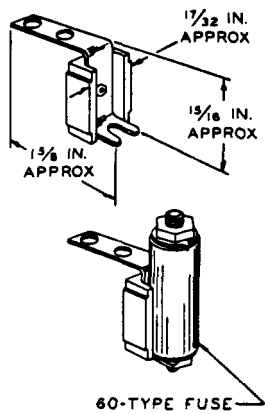

Fig. 17-The 14A Fuse Holder

10.00 THE 14A FUSE HOLDER

10.01 When required, the 60-type fuse may be attached to 1A3A, 1A4A, and similar protected cable terminals with a 14A fuse holder.

10.02 Fuse holder is a fiber detail riveted to a Z-shaped metal bracket, see Fig. 17. Two holes are located in one leg for attachment to either binding post of a cable pair. Wire is connected under fuse nut as shown in Fig. 18.

Fig. 18 — Mounting and Wiring 14A Fuse Holder

