

## STATION EQUIPMENT

### JACKS, PLUGS, AND ADAPTERS

#### IDENTIFICATION, INSTALLATION, AND SERVICE

	CONTENTS	PAGE	
1.	<b>GENERAL</b> . . . . .	1	<b>1. GENERAL</b>
2.	<b>IDENTIFICATION</b> . . . . .	1	<b>1.01</b> This section provides information on jacks, plugs, and adapters for indoor and outdoor use.
	<b>A. Jacks</b> . . . . .	2	<b>1.02</b> The reasons for reissuing this section are listed below. Revision arrows are used to emphasize the more significant changes.
	<b>B. Plugs</b> . . . . .	4	(a) Add information on 267A2 adapter and rate 267A manufacture discontinued (MD) adapter
	<b>C. Adapters and Converters</b> . . . . .	9	(b) Add information on 267C adapter
	<b>D. Weatherproof Cords</b> . . . . .	11	(c) Add information on 400B adapter
	<b>E. Boxes and Housings</b> . . . . .	12	(d) Add information on B and C weatherproof cords
	<b>F. Brackets</b> . . . . .	13	(e) Rate the following plugs and jacks MD:
	<b>G. Faceplates and Cover</b> . . . . .	13	● 504A plug (all colors)
3.	<b>JACKS AND JACK MOUNTINGS — INDOOR</b> . . . . .	22	● 505A-49 plug
	<b>A. Installation of Nonflush Jacks</b> . . . . .	23	● 541A jack (all colors)
	<b>B. Installation of Flush-Type Jacks in Standard Electrical Outlet Boxes</b> . . . . .	24	● 547A jack (all colors)
	<b>C. Installation of Flush-Type Jacks in 63-Type or KS-20502 Type Bracket</b> . . . . .	25	● 548A-49 and 548A-54 jacks
4.	<b>JACKS AND JACK MOUNTINGS — OUTDOOR</b> . . . . .	28	● 549A-49 jack
5.	<b>PLUGS — INDOOR AND OUTDOOR</b> . . . . .	34	● 550A-49 and 550A-54 jacks
6.	<b>ADAPTERS</b> . . . . .	35	● 551A jack (all colors).
			<b>2. IDENTIFICATION</b>
			<b>2.01</b> Table A lists jacks and mating plugs for telephone set use. The table shows indoor and outdoor location, contacts, and method of mounting.

**NOTICE**

Not for use or disclosure outside the  
Bell System except under written agreement

♦TABLE A♦

## JACK AND MATING PLUGS—SELECTION

LOCATION	NO. PINS	MOUNTED	JACK	MATING PLUG
Indoor	4	Nonflush	404B (MD) 549A	283B (MD) or 505A (MD)
		Outlet Box	493A (MD) 497A (MD) 548A 550A	
	12	Nonflush	551A (MD)	504A (MD)
	12	Outlet Box	541A (MD) 547A (MD) 547B (MD)	504A (MD)
Outdoor	3	Includes Housing	KS-8420 (MD) KS-8421 (MD)	KS-8419 (MD)
	3	B Outlet Box	B Weatherproof Type	B or C Weatherproof Cord
	3	Flush Mounted	B Waterproof	B or C Weatherproof Cord
	4 or 12	KS-19316, List 4*	493A (MD) 541A (MD) 548A	504A (MD) 505A (MD)
		KS-20202, List 1*	541A (MD) 548A	

\* Will also accept a 625F connecting block in modular installations.

**2.02** For detailed information covering the installation of B weatherproof-type jacks, refer to Section 461-220-101 entitled Recreational Vehicle Wiring — Nonpermanent Type.

#### A. Jacks

**2.03 404B (MD) Jack:** The 404B (MD) jack (Fig. 1) is a moulded plastic, 4-pin, surface-mounted jack made for indoor use.

**2.04 497A (MD) Jack:** The 497A (MD) jack (Fig. 2) is a moulded plastic, 4-pin, flush-mounted jack made for indoor use.

**2.05 ♦541A (MD) Jack:** The 541A (MD)♦ jack (Fig. 3 and 4) is a moulded plastic, 12-pin, flush-mounted jack for indoor or outdoor use.

**2.06 ♦547-Type (MD) Jack:** The 547-type (MD) jack♦ (Fig. 5) consists of a 541A (MD) jack, a

43B bracket, and a plastic faceplate. The 547-type (MD) jack is used for flush-type mounting on outlet boxes in indoor locations.

**2.07 548A Jack:** The 548A jack (Fig. 6) is a moulded plastic, 4-pin, flush-mounted jack for indoor or outdoor use.

**2.08 549A Jack:** The 549A jack (Fig. 7) is a moulded plastic, 4-pin, surface-mounted jack for indoor use.

**2.09 550A Jack:** The 550A jack (Fig. 8) consists of a 548A jack, a 43B bracket, a faceplate, and mounting screws. The 550A jack is for indoor use only.

**2.10 ♦551A (MD) Jack:** The 551A (MD)♦ jack (Fig. 9) is a moulded plastic, 12-pin, surface-mounted jack for indoor use.

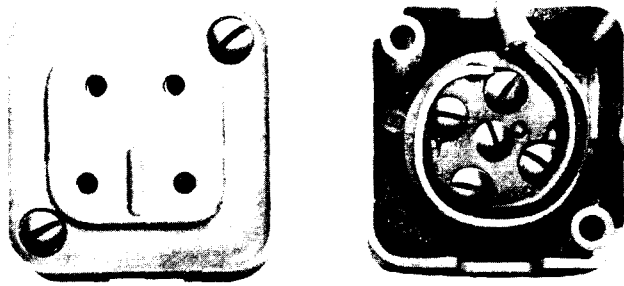

- REPLACED BY 549A JACK
- 4 CONTACTS
- NONFLUSH MOUNTED (MD)
- MATES WITH 505A PLUG
- MOUNTING HARDWARE SUPPLIED

Fig. 1—404B (MD) Jack

**2.11 KS-8420 (MD) Jack:** The KS-8420 (MD) jack (Fig. 10) is a 3-contact, flush-mounted weatherproof jack and housing. It can only be used with the KS-8419 (MD) plug.

**2.12 KS-8421 (MD) Jack:** The KS-8421 (MD) jack (Fig. 11, 12, and 13) is a 3-contact, surface-mounted weatherproof jack and housing. It can be used with the KS-8419 (MD) plug. The KS-8421 (MD) jack housing may be converted for use with the B weatherproof cords by using the B weatherproof female jack adapter.

**2.13 B Weatherproof Male Jack:** The B weatherproof male jack (Fig. 14 and 15) mounts in the B outlet box on the recreational vehicle, houseboats, etc, and receives the female plug of the B weatherproof cord to provide telephone service to recreational vehicles. The jack has a spring-loaded hinged cover to make it weatherproof when not in use. Three screw terminals stamped R, T, and GR on the rear of jack provide connection to ring, tip, and ground.

**2.14 B Weatherproof Female Jack:** The B weatherproof female jack (Fig. 14 and 16) looks the same as the male jack except for the pins, and mounts in the B outlet box *at the trailer service pad or on the dock at the marina*. It receives the male plug of the B or C weatherproof cord.

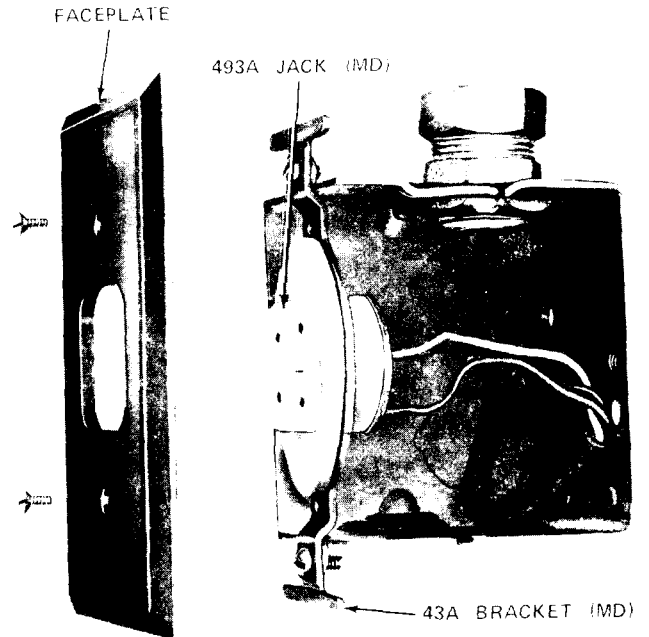

- REPLACED BY 550A JACK
- 4 CONTACTS
- FLUSH WALL MOUNTED
- MATES WITH 505A PLUG (MD)
- MOUNTING HARDWARE SUPPLIED

Fig. 2—497A (MD) Jack Mounted in Standard Electrical Outlet Box

**2.15 B Waterproof Male Jack:** The B waterproof male jack (Fig. 17 and 18) is mounted on a boat and receives the female plug of the B weatherproof cord to provide telephone service to boats. It is chrome plated with hinged, threaded cover to make the jack waterproof when not in use. Three screw terminals on the rear of the jack stamped R, T, and GR provide connections.

**2.16 652WP4 Jack:** The 652WP4 jack (Fig. 19 and 20) is intended for use with modular apparatus at outdoor locations but can also be used at indoor locations where severe environmental conditions exist such as steel mills, foundries, etc. **The 652WP4 jack is not to be used as a replacement for the weatherproof, 3-conductor jacks used for marina and recreational vehicle installations.**

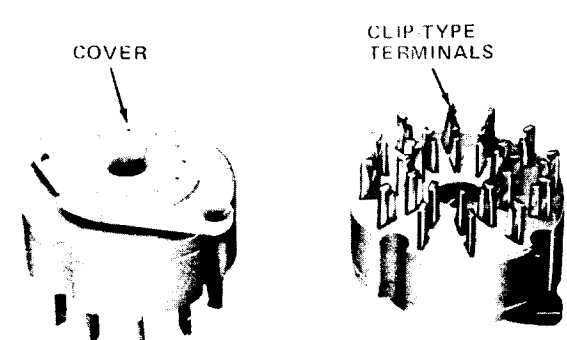

- 12 CONTACTS
- FLUSH MOUNTED USING 63-TYPE OR KS-20502, LIST 2 BRACKET AND 16A FACEPLATE
- MATES WITH 504A PLUG (MD)

Fig. 3—541A (MD) Jack

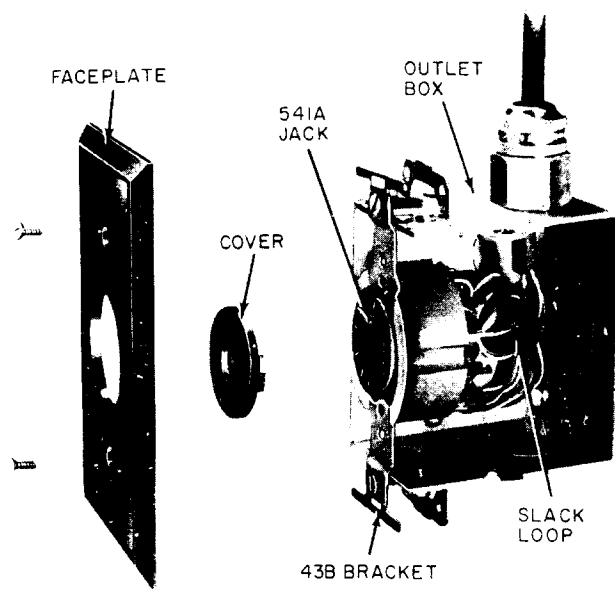

- 12 CONTACTS
- FLUSH WALL MOUNTED MATES WITH 504A PLUGS (MD)
- MOUNTING SCREWS AND FACEPLATE SUPPLIED
- OPTIONAL COLOR FACEPLATE

Fig. 5—547B (MD) Jack Mounted in Standard Electrical Outlet Box

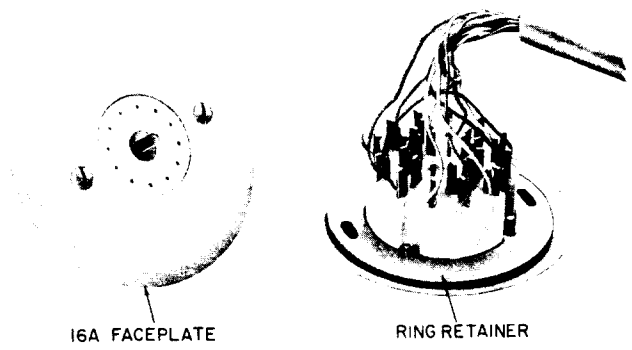

Fig. 4—541A (MD) Jack With Faceplate and Terminated 541A (MD) Jack Using Retainer

**B. Plugs**

**2.17 423A Plug:** The 423A plug (Fig. 21) is a 2-piece, 4-contact molded plastic plug for use inside the 750-type panel telephone set. The U-shaped projections are molded in the base for securing the mounting cord. Refer to Table C for color availability.

**2.18 478A Plug:** The 478A plug (Fig. 22) is a flexible twin-double conductor plug. It contains a 616P miniature modular jack and a 100-ohm 1-watt

resistor. It is arranged so each plug finger may be turned 90 degrees in the shell to present a new surface for wear. It is intended to be used with G15- and K1-type headsets in place of the G3CR- and G3L-type handsets.

**2.19 478B Plug:** The 478B plug is identical to the 478A plug except it is not equipped with the 100-ohm 1-watt resistor.

**2.20 504A (MD) Plug:** The 504A (MD) plug (Fig. 23 and 24) is a 12-terminal plug consisting of a molded plastic block, cord tip guide, and cap assembly held together by one screw. Each terminal is equipped with a socket-type connector to receive the cord tip. A cord tip guide covers the terminals. The terminals are numbered 1 through 12 and match numbering on the 541A (MD) jack. The plug can be inserted into the jack in only one position. It was



- 4 CONTACTS
- FLUSH MOUNTED:  
USING 63-TYPE OR KS-20502, LIST 2  
BRACKET AND 16A FACEPLATE OR IN  
STANDARD ELECTRICAL OUTLET BOX  
USING 43B BRACKET OR IN WOODWORK  
USING 1-1/4 INCH HOLE
- MATES WITH 505A PLUG (MD)
- MOUNTING SCREWS SUPPLIED
- REPLACES 493A JACK (MD)

Fig. 6—548A Jack

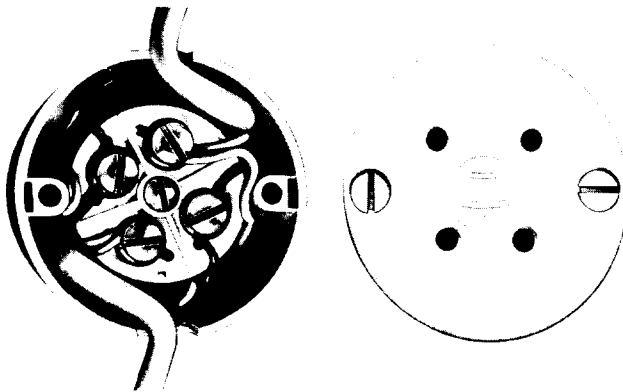

- 4 CONTACTS, DOUBLE  
TERMINAL
- NON FLUSH BASEBOARD  
MOUNTED
- MATES WITH 505A PLUG (MD)
- MOUNTING SCREWS SUPPLIED

Fig. 7—549A Jack



- 4 CONTACTS
- COMPONENTS:  
548A JACK  
43B BRACKET  
FACEPLATE
- EARLY PRODUCTION SUPPLIED  
WITH 43A BRACKET (MD)
- MATES WITH 505A PLUG (MD)
- 6 MOUNTING SCREWS SUPPLIED

Fig. 8—550A Jack Mounted

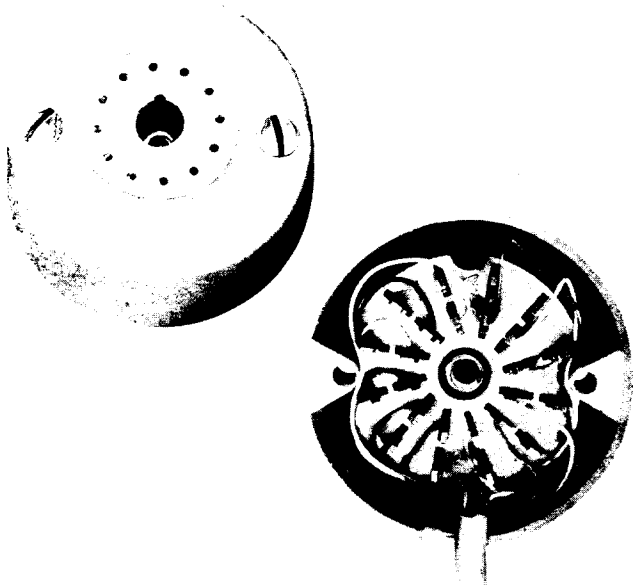

- 12 CONTACTS
- NONFLUSH BASEBOARD MOUNTED
- MATES WITH 504A PLUG (MD)
- MOUNTING SCREWS SUPPLIED

Fig. 9—KS-551A (MD) Jack

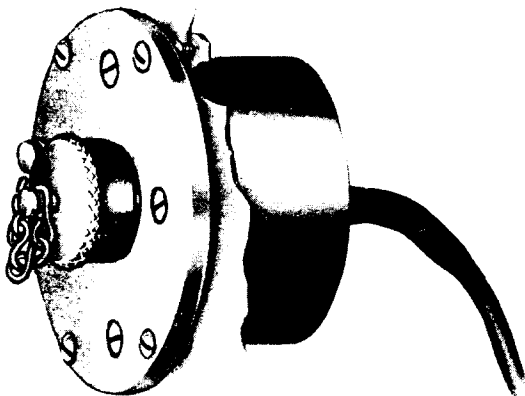

- FLUSH MOUNTED JACK
- USED KS-8419 PLUG (MD)

Fig. 10—KS-8420 (MD) Jack Installed

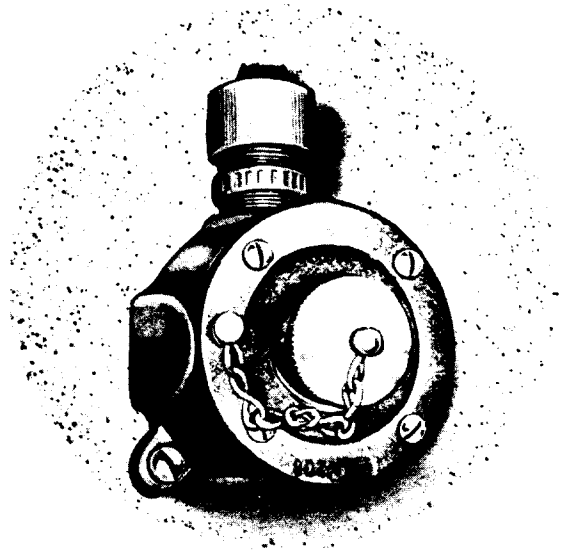

- SURFACE MOUNTED JACK
- USES KS-8419 PLUG (MD)

Fig. 11—KS-8421 (MD) Jack

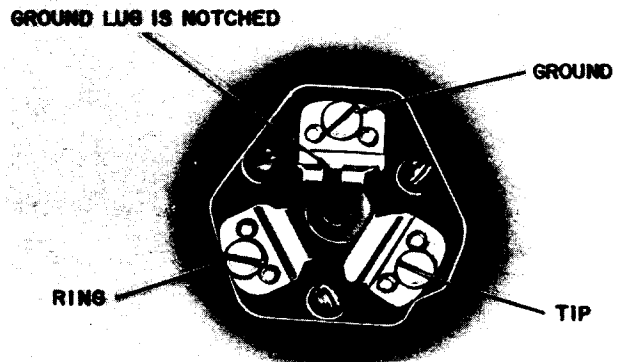

Fig. 12—Connections for KS-8420 and KS-8421 (MD) Jacks

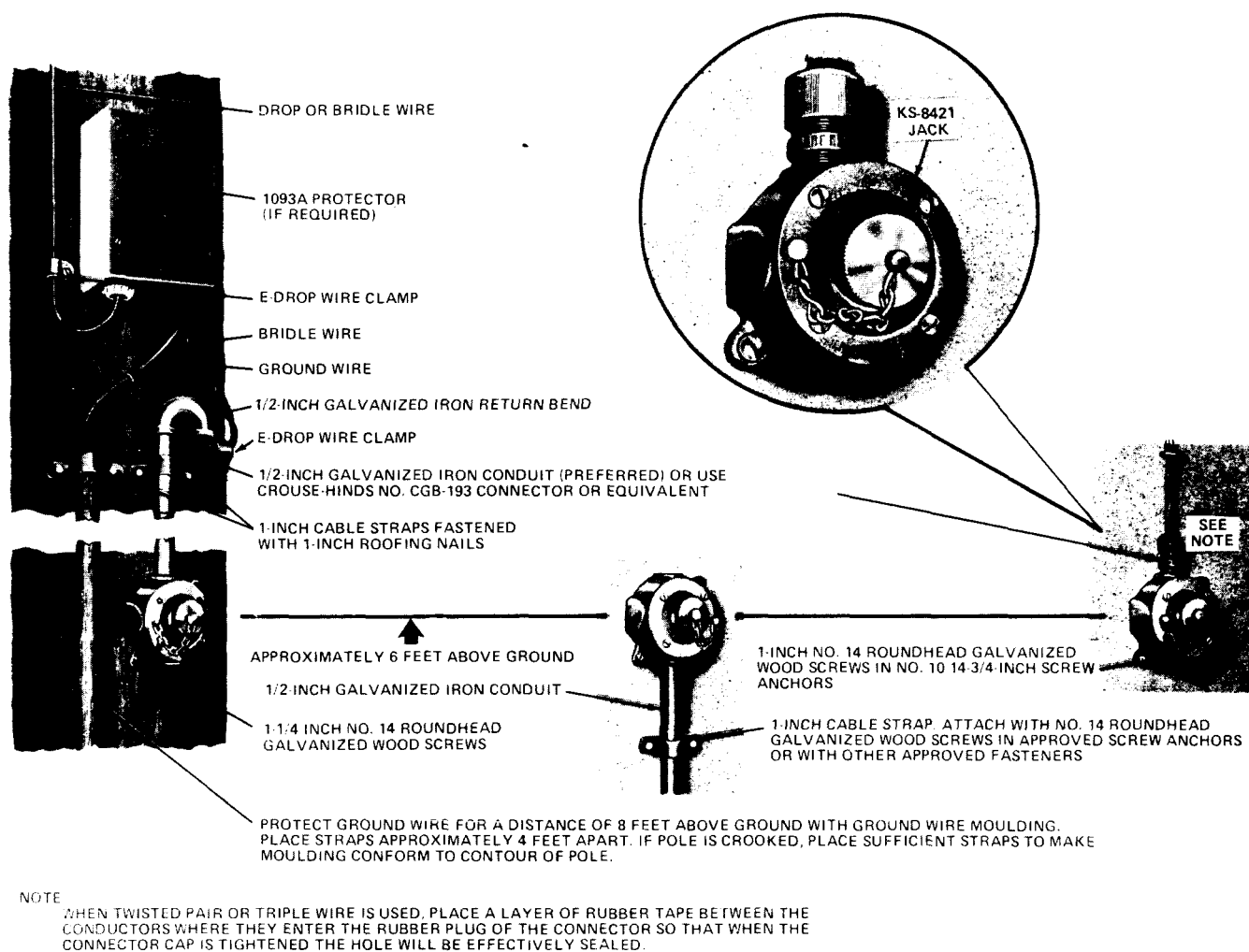

Fig. 13—KS-8421 (MD) Jack Typical Installation

available in colors shown in Table C. Included with the plug is a metal cord stay designed for use with cords equipped with a wire S hook (Fig. 24). The S hook is removed and discarded. The cord stay, inserted into the vacated band hole, serves as a wing band. Slots are provided on the plug block and shell to hold a wing band or the cord stay. The wing band or cord stay seated in the slot prevents the mounting cord from slipping out of the plug.

**2.21 505A (MD) Plug:** The 505A (MD) plug (Fig. 25, 26, and 27) is a 4-contact plug similar to the 504A plug; in addition, however, it has a cord fastener which holds the cord in place while spade tips are being connected. The cord fastener also anchors the mounting cord in the assembled plug. The

plug is available in colors shown in Table C. The current model cord tip guide provides a cutout to permit the use of a cord equipped with a flat eyelet stay band.

**2.22 KS-8419 (MD) Plug:** The KS-8419 (MD) plug (Fig 28) is a 3-contact, brass plug intended for connecting telephone sets installed on boats, trains, or auto trailers to outdoor jacks of PBX or central office (CO) lines. This plug is intended for use with KS-8420 (MD) jacks. This plug has been replaced by the B and C weatherproof cords which have plugs attached and are intended to be used with B weatherproof jack, B waterproof jacks, and B weatherproof jack adapter.

NOTE:  
REAR OF MALE JACK  
LOOKS THE SAME.

B WEATHERPROOF  
FEMALE JACK  
(SEE NOTE)

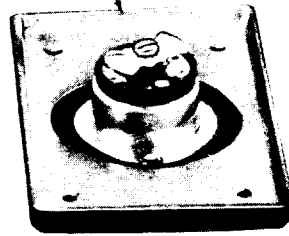
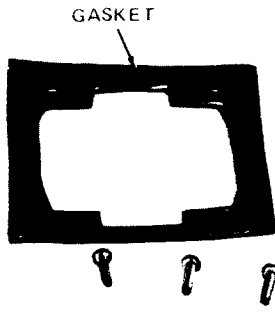

COVER  
MOUNTING  
SCREWS

Fig. 14—B Weatherproof Male (or Female) Jack

B WEATHERPROOF  
FEMALE JACK

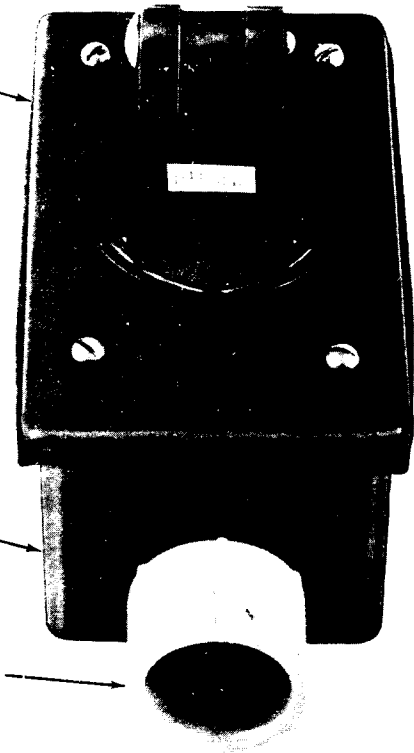

B OUTLET  
BOX

CONDUIT  
ADAPTER

Fig. 16—B Weatherproof Female Jack on B Outlet Box

B WEATHERPROOF  
MALE JACK

B OUTLET  
BOX

CORD GRIP  
ASSEMBLY

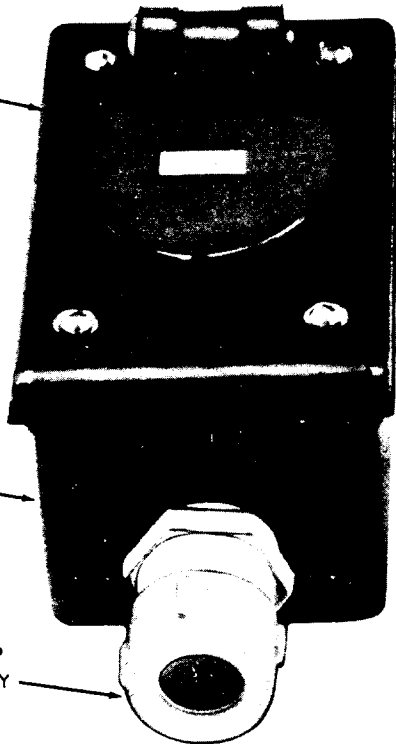

Fig. 15—B Weatherproof Male Jack on B Outlet Box

CHROME PLATED  
SCREW COVER

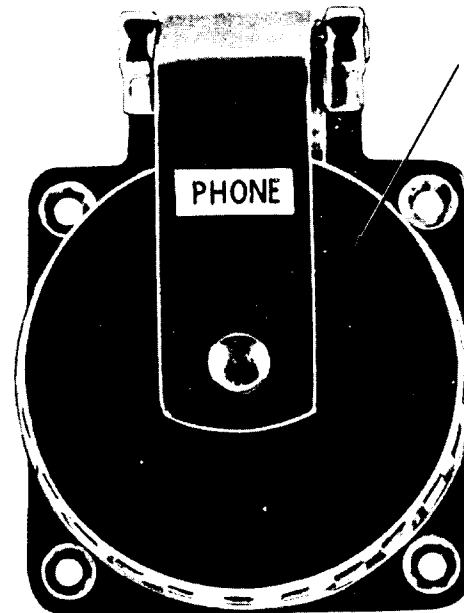

Fig. 17—B Waterproof Male Jack (Front View)



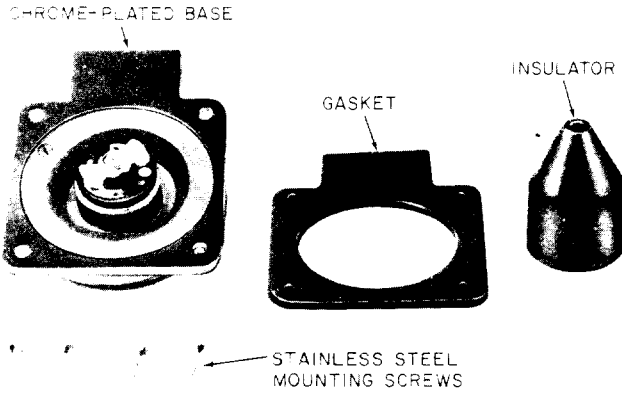

Fig. 18—B Waterproof Male Jack (Rear View, Gasket and Insulator Removed)

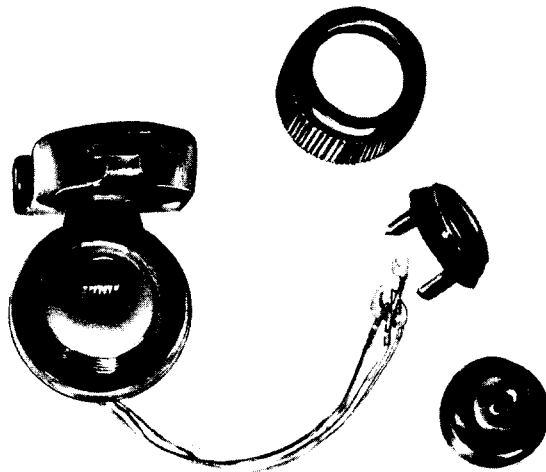
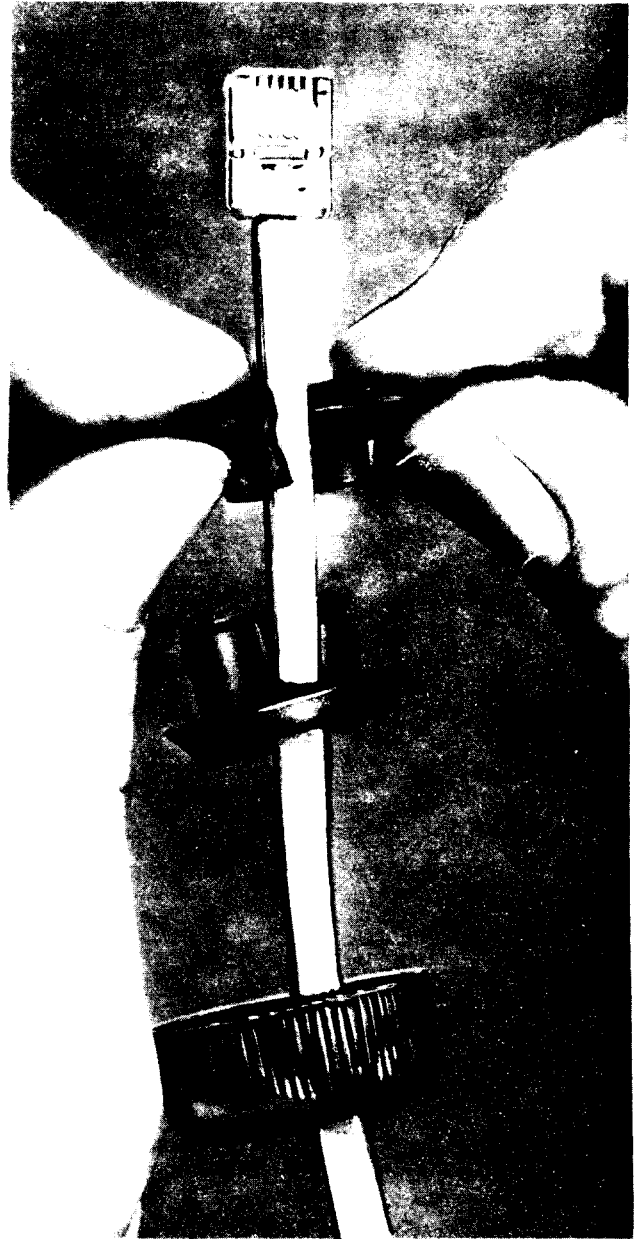

Fig. 19—652WP4 Jack

**C. Adapters and Converters**

**2.23 B Weatherproof Female Jack Adapter:**

The B weatherproof female jack adapter (Fig. 29 and 30) mounts on an existing KS-8421 (MD) jack housing after the old jack and front plate are removed. It will receive the male plug of the B or C weatherproof cord to provide telephone service to recreational vehicles or boats. A spring-loaded hinged cover protects the jack from weather when



NOTE:  
NOT FOR USE ON MOBILE HOMES,  
IN MARINAS OR ON RECREATIONAL  
VEHICLES. FOR SUCH APPLICATIONS  
SEE FIG. 46 AND 47.

Fig. 20—Installing 652WP4 Jack Parts on Modular Cord

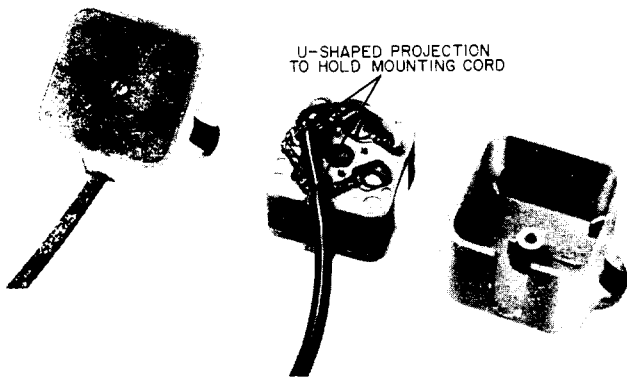

Fig. 21—423A Plug, Front View and Rear View, Cover Removed

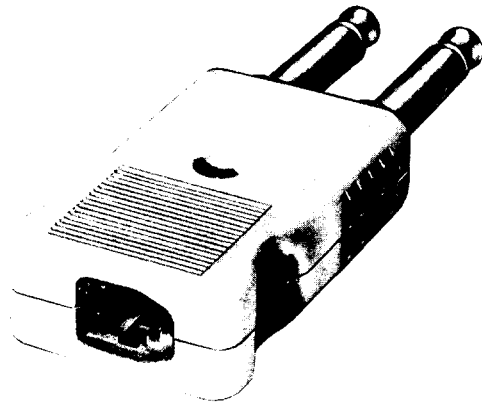

Fig. 22—478-Type Plug

not in use. A rubber boot on the mating connector of the cord provides a weatherproof seal when in use. Three screw terminals on rear of jack stamped T, R, and GR provide connections.

**2.24 224A Adapter:** The 224A (six pin) adapter (Fig. 31) is used to adapt the D4BU mounting cord to the 541A (MD) and 551A (MD) jacks (12-pin jack).

**2.25 225A Adapter:** The 225A (four pin) adapter (Fig. 32) is used to adapt the D4BU mounting cord to 404B (MD), 493A (MD), 497A (MD), 548A, and 549A jacks (4-pin jacks). The 541A (MD), 551A (MD), 548A, and 549A jacks should not be mixed with 625-

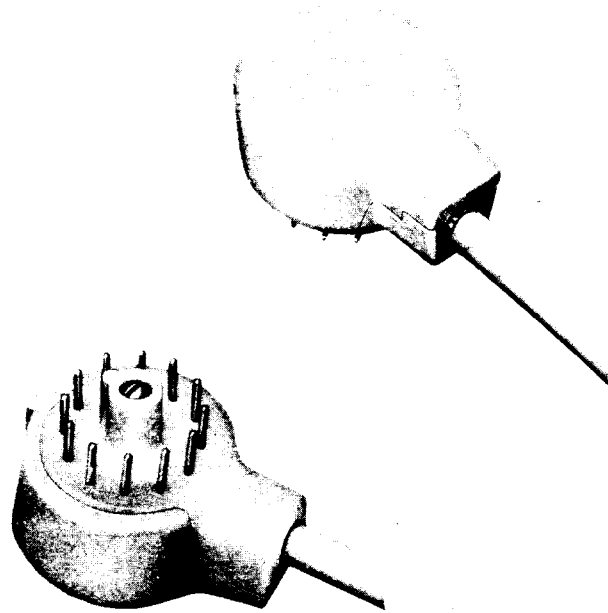

Fig. 23—504A (MD) Plug

type connecting blocks where the telephone service is required. The adapter will be available in white (-121) only — former versions were available in ivory or translucent.

**2.26 1A Converter:** The 1A converter (Fig. 33) is used to convert the 404B (MD), 493A (MD), 497A (MD), 548A, and 549A jacks (4-pin jacks) to the modular system. The 1A converter, when plugged into a 4-pin jack, is designed to be nonremovable.

**2.27 267A-Type Adapter:** The 267A (MD) (Fig. 34) and the 267A2 (Fig. 35) adapters consist of two 6-conductor line cord modular jacks and a modular 6-conductor plug all in one package. Four of the 6-contacts of each jack are connected to the same numbered contacts of the plug. The other two contacts of the jacks are connected to each other (Fig. 36). The 267A2 adapter is a cost-reduced version of the 267A (MD) adapter. The obvious physical difference between the two adapters are as follows:

- (a) The 267A2 adapter has the jack openings located one above the other.
- (b) The 267A (MD) has the jack openings located side-by-side.

**2.28 267C Adapter:** The 267C adapter (Fig. 37) is externally similar to the 267A (MD) adapter

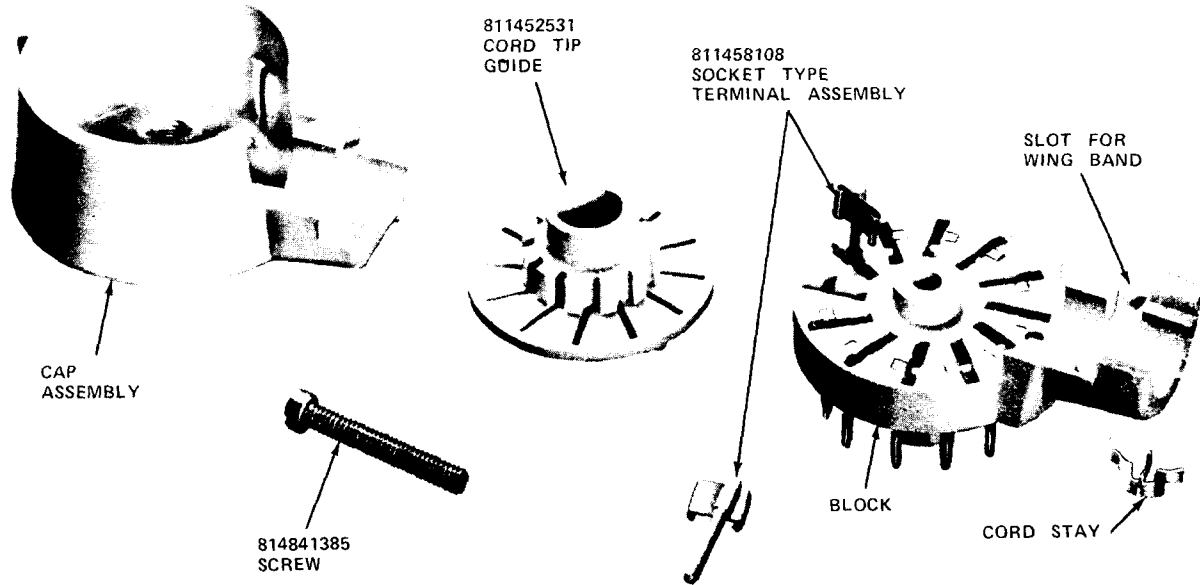

Fig. 24—504A (MD) Plug Disassembled

with two side-by-side 6-position modular jacks and one 6-position modular plug connected internally as shown in Fig. 38. The 267C adapter is intended to interface Small Communication System (SCS) control modules with control office lines.

**2.29 281A (MD) Adapter:** The 281A (MD) adapter (Fig. 39) is used to plug into the 623-type line cord jack in the base of the PRINCESS® telephone. This adapter allows the installation of dial illumination transformers without connecting the power to the inside station wiring. See Fig. 40 for wiring of adapter.

**2.30 338A Adapter:** The 338A adapter (Fig. 41) connects at the 625-type connecting block and has two modular jacks, either of which may be used to connect the 2012C transformer (required for a dial light PRINCESS telephone) or the telephone set. The adapter is wired internally to prevent transformer power from being connected to the service wiring (Fig. 42).

**2.31 400B Adapter:** The 400B adapter (Fig. 43) is similar in appearance to the other modular adapters except it has an 8-position and 6-position modular jacks side-by-side connected to an 8-position plug as shown in Fig. 44. The 400B adapter is in-

tended to provide local power from a wall-mounted power supply to the proper conductors in the line cord of the telephone set for the Advanced Business Communication System (ABCS).

**2.32 B Adapter Plate:** The B adapter plate (Fig. 45) is used to adapt the B waterproof jack (AT-8731) to a boat where the KS-8420 (MD) jack had previously been mounted.

**Note:** The B adapter plate has two sets of mounting holes. Only one set of holes is used. The second set is available in case the holes from the old KS-8420 (MD) jack interfere with adequate mounting of the adapter plate. The rubber gasket is made so that when placed between the boat and the adapter plate, the holes in the gasket line up with one set of holes in the adapter plate. Turning the gasket over causes the gasket holes to line up with the second set of adapter plate holes. This provides a water-tight seal.

#### D. Weatherproof Cords

**2.33 B Weatherproof Cord:** The B weatherproof cord (Fig. 46) comes in 50-, 100-, and 150-foot lengths and consists of 16-gauge, 3-wire (tip,



Fig. 25—505A (MD) Plug

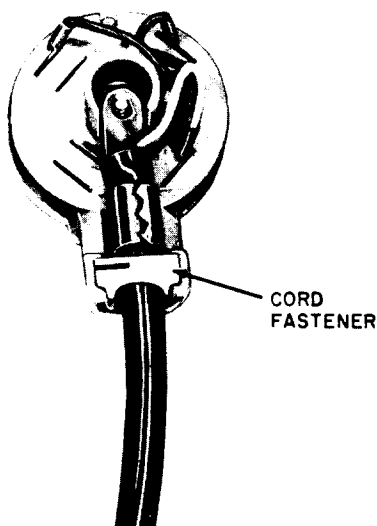

Fig. 26—Current Model D3BU Cord Connected to Current Model 505A (MD) Plug

ring, and ground) yellow PVC insulated flexible cord, with PHONE stamped on the cord at 1-foot intervals for identification. The cord is terminated on one end with a male plug which engages the B weatherproof female jack at the service pad or dock. The other end is terminated in a female plug which engages the male jack on the recreational vehicle or boat. Rubber boots on the plug mate with their respective jacks to provide weather protection.

**2.34 C Weatherproof Cord:** The C weatherproof cord (Fig. 47) is constructed the same and comes in the same lengths as the B weatherproof cord except that the female plug is replaced with a

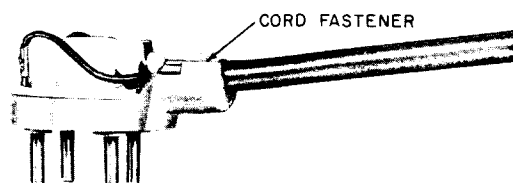
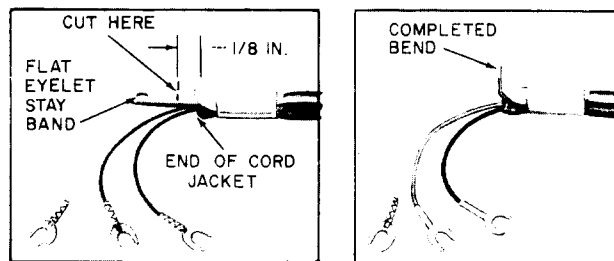

Fig. 27—Connecting Current Model D3BU or D4BP Cord to Early Model 505A (MD) Plug

stay hook and spade-tipped conductors for termination in a telephone set.

**2.35 KS-15143 Cordage:** The KS-15143 cordage is a 3-conductor, 18-gauge, flexible cordage ordered in the length needed for use with the KS-8419 (MD) plug when connecting telephone sets on boats, trains, or trailers to outdoor jacks.

#### E. Boxes and Housings

**2.36 B Outlet Box:** The B outlet box (Fig. 48) is a phenolic box for mounting the B weatherproof male or female jacks. It has a threaded knock-out entrance at each end for use with an aluminum cord grip assembly or PVC conduit adapter. The cord grip assembly and conduit adapter ship with the outlet box.

**2.37 KS-19316, List 4 Weatherproof Housing:** The KS-19316, List 4 weatherproof housing (Fig. 49) is a surface- or recess-mounted box for a telephone jack for outdoor use. It consists of a rectangular aluminum alloy box, a rubber-gasketed cover having a circular opening capable of being sealed by a spring-hinged door, and a bracket which will mount 493A (MD), 541A (MD), 548A, and 625F jacks.

**2.38 KS-19316, List 5 Cover:** The KS-19316, List 5 cover (Fig. 50) consists of a replacement

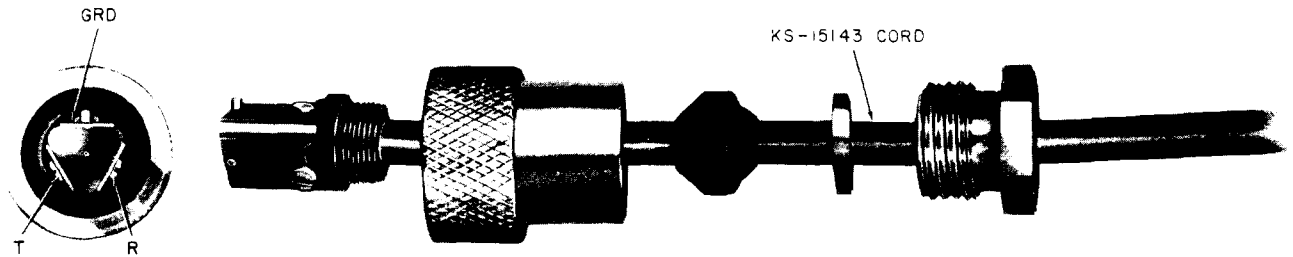

Fig. 28—KS-8419 (MD) Plug

cover, gasket, and bracket with mounting screws for the KS-19316, List 4 weatherproof housing.

**2.39 KS-19316, List 6 Housing Box:** The KS-19316, List 6 housing box (Fig. 51 and 52) consists of a replacement box, connector, and grommets for the KS-19316, List 4 weatherproof housing.

**2.40 KS-20202, List 1 Weatherproof Housing:** The KS-20202, List 1 housing (Fig. 53) is a surface-mounted box for a telephone jack for outdoor use. Mounted on a vertical surface, it provides improved weather protection with a hooded and downward-tilting opening covered by a rubber gasketed cover and sealed with a spring-hinged door. It contains a bracket which will mount a 493A (MD), 541A (MD), 548A, or 625F jack.

**2.41 KS-20202, List 2 Weatherproof Box:** The KS-20202, List 2 box is a replacement box, connector, and grommets for the KS-20202, List 1 housing.

#### F. Brackets

**2.42 43-Type (MD) Bracket:** The 43-type (MD) bracket (Fig. 54) is rated MD and is replaced by the 842615544 bracket which is supplied as part of the 65A faceplate (Fig. 63). The 842615544 bracket will also be supplied as a component of the 547B jack, 550A jack, and 625B connecting block.

**2.43 63-Type Bracket:** The 63A (MD) (Fig. 55) and 63B (Fig. 56) brackets were used to prewire telephone outlets in building during construction. They may be used with flush-type jacks such as the 493A (MD), 541A (MD), 548A, or 625F connecting block.

**2.44 KS-20502 Type Bracket:** The KS-20502, List 1 (MD) (Fig. 57) and List 2 (Fig. 58) bracket

are made of plastic and provide a mounting facility for flush-type jacks in existing walls (post wiring). They may be used with the 541A (MD) or 548A jacks or the 625F connecting block.

**2.45 B Mounting Bracket:** The B mounting bracket (Fig. 59, 60, and 61) is used to mount the B outlet box on trailers and other recreational vehicles. It consists of a stainless steel angle-bracket with three clearance holes on one side for attaching the bracket to the trailer hitch and two threaded holes on the other side for mounting the B outlet box. Included are three stainless steel thread-cutting screws for attaching the bracket and two stainless steel screws with spacers for mounting the outlet box on the bracket. A pigtail lead is included to connect between the center ground terminal of the B weatherproof male jack and one of the mounting screws for the outlet box to provide a ground bond to the vehicle frame.

#### G. Faceplates and Cover

**2.46 16-Type Faceplate:** The 16-type faceplate (Fig. 62) is designed to be used with the 63-type bracket or the KS-20502 type bracket on flush-type telephone jack installations. The faceplate comes equipped with a ring retainer and mounting screws. The ring retainer is used when mounting on the 63-type bracket and is not used with the KS-20502 type bracket.

**2.47 65A Faceplate:** The 65A faceplate (Fig. 63) may be used with the 43-type, 63-type, or KS-20502 type brackets or any standard signal telephone outlet box for flush-type jack installations using the 541A (MD) or 548A jacks or the 625F connecting block or to cover unequipped telephone outlet locations.

**2.48 158A Cover:** The 158A cover (Fig. 64) is a moulded rubber cover to be placed over the

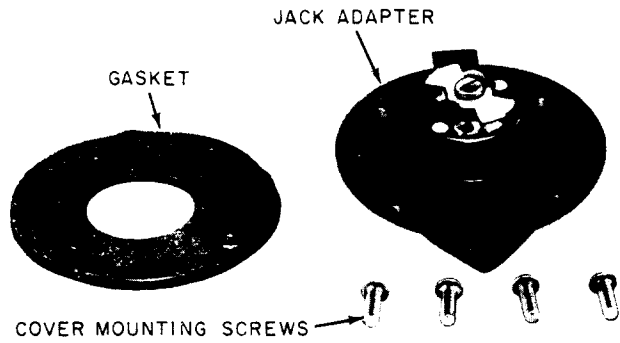

Fig. 29—B Waterproof Female Jack Adapter



Fig. 31—224A Adapter

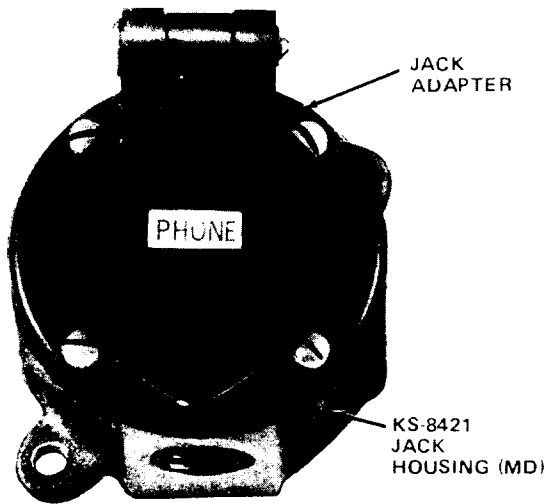

Fig. 30—B Weatherproof Female Jack Adapter Mounted on KS-8421 (MD) Jack Housing

screw terminals on the rear of the 625F and 47F (MD) connecting blocks and the 548A jack to prevent corrosion of the screws and jack when placed in an outside wall when liquid foam type insulation has been used.

2.49 The illustration index is as follows:

◆Fig. 1—404B (MD) Jack◆

Fig. 2—497A (MD) Jack

◆Fig. 3 and 4—541A (MD) Jack◆

◆Fig. 5—547B (MD) Jack◆

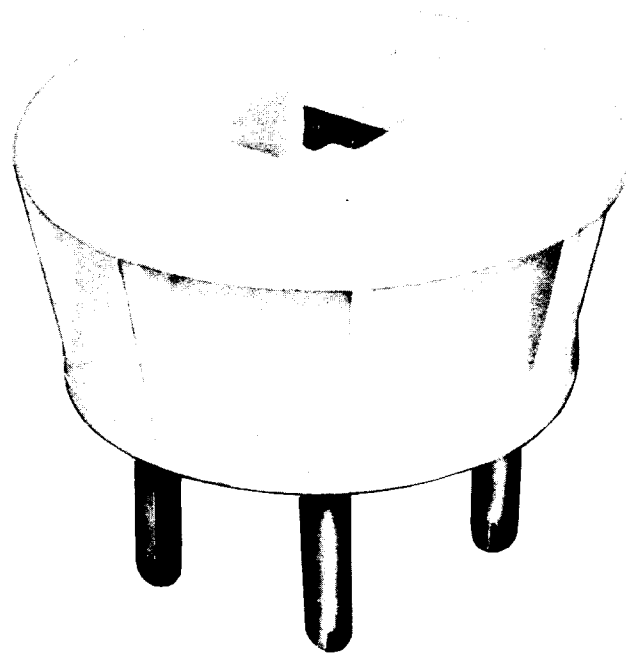
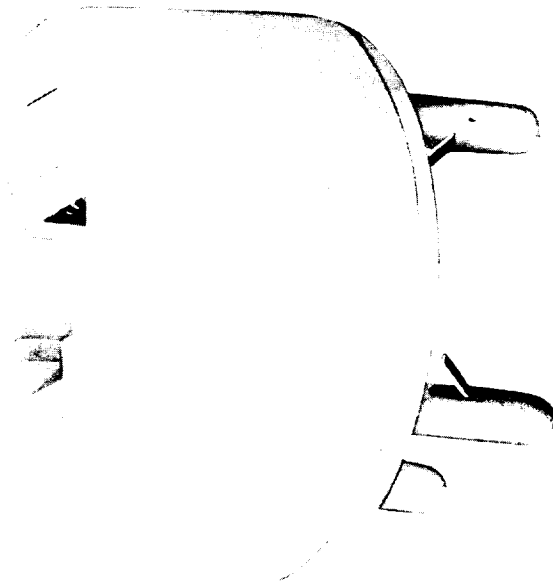
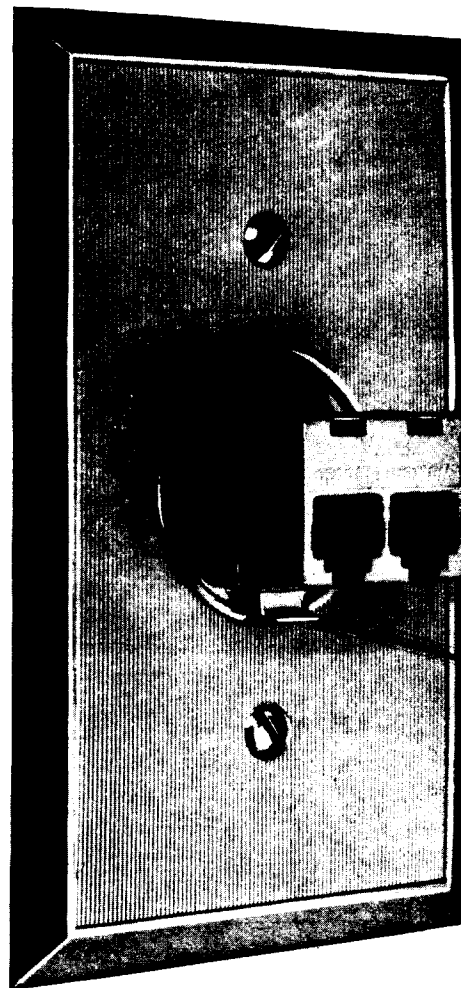

Fig. 32—225A Adapter



**Fig. 33—1A Converter**

- ◆Fig. 6—548A Jack◆
- ◆Fig. 7—549A Jack◆
- ◆Fig. 8—550A Jack◆
- ◆Fig. 9—551A (MD) Jack◆
- ◆Fig. 10—KS-8420 (MD) Jack◆
- ◆Fig. 11, 12, and 13—KS-8421 (MD) Jack◆
- Fig. 14, 15, and 16—B Weatherproof Jack
- Fig. 17 and 18—B Waterproof Jack
- Fig. 19 and 20—652WP4 Jack
- Fig. 21—423A Plug
- Fig. 22—478-Type Plug
- ◆Fig. 23 and 24—504A (MD) Plug◆
- ◆Fig. 25, 26, and 27—505A Plug◆
- ◆Fig. 28—KS-8419 (MD) Plug
- ◆Fig. 29 and 30—B Weatherproof Female Jack Adapter◆



**Fig. 34—◆267A (MD) Adapter (Plugged Into 625B Connecting Block)◆**

- Fig. 31—224A Adapter
- Fig. 32—225A Adapter
- Fig. 33—1A Converter
- ◆Fig. 34—267A (MD) Adapter◆
- ◆Fig. 35—267A2 Adapter◆
- ◆Fig. 36—Schematic Diagram, 267A Type Adapter◆
- ◆Fig. 37—267C Adapter◆

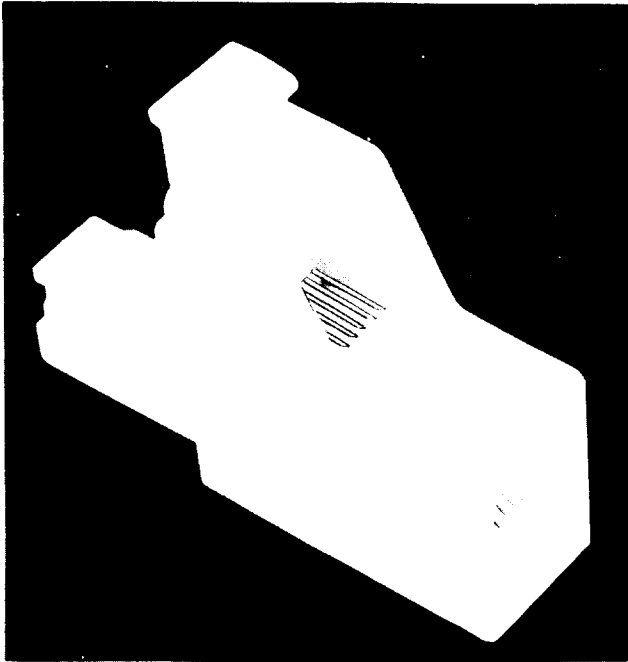

Fig. 35—267A2 Adapter

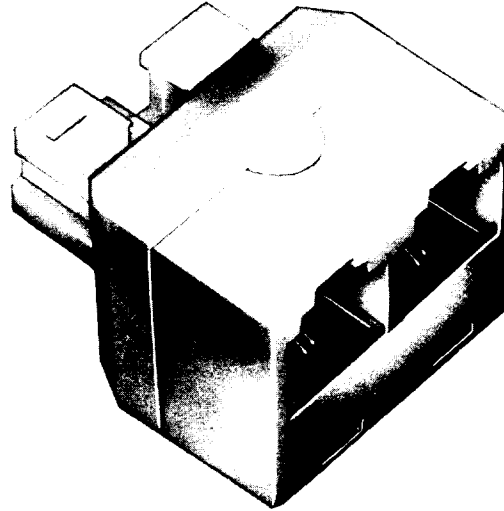

Fig. 37—267C Adapter

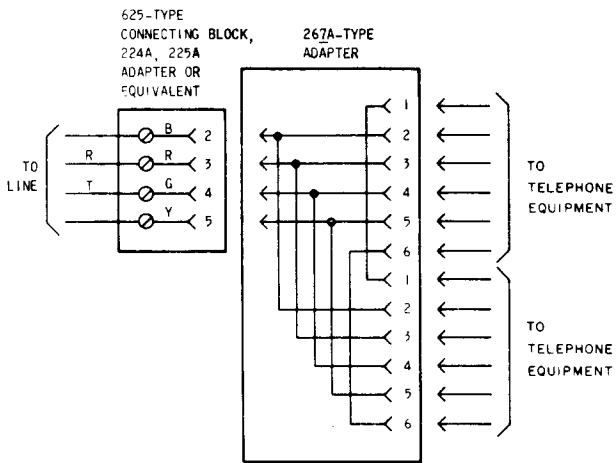

Fig. 36—Schematic Diagram, 267A Type Adapter

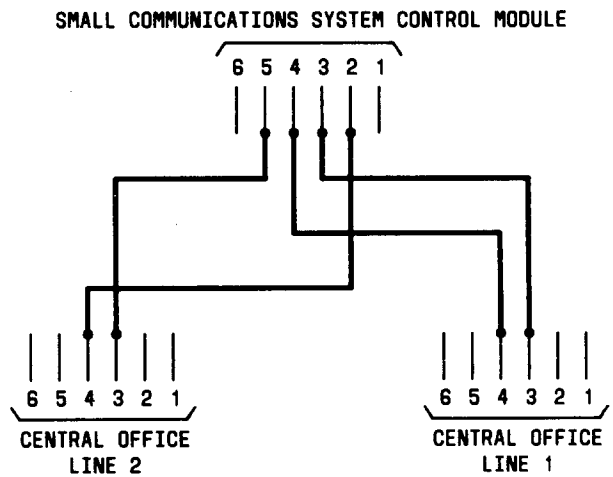

Fig. 38—Schematic Diagram, 267C Adapter



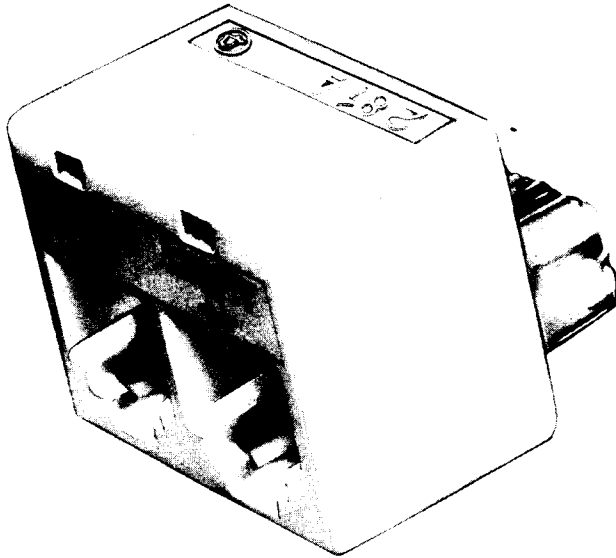

Fig. 39—281A (MD) Adapter

◆Fig. 38—Schematic Diagram, 267C Type Adapter◆

Fig. 39—281A (MD) Adapter

◆Fig. 40—Schematic Diagram, 281A (MD) Adapter◆

Fig. 41—338A Adapter

Fig. 42—Schematic Diagram, 338A Adapter

Fig. 43—400B Adapter

Fig. 44—Schematic Diagram, 400B Adapter

Fig. 45—AT-8731 B Adapter Plate

Fig. 46—B Weatherproof Cord

Fig. 47—C Weatherproof Cord

Fig. 48—B Outlet Box

Fig. 49—KS-19316, List 4 Housing

Fig. 50—KS-19316, List 5 Cover

Fig. 51 and 52—KS-19316, List 6 Housing

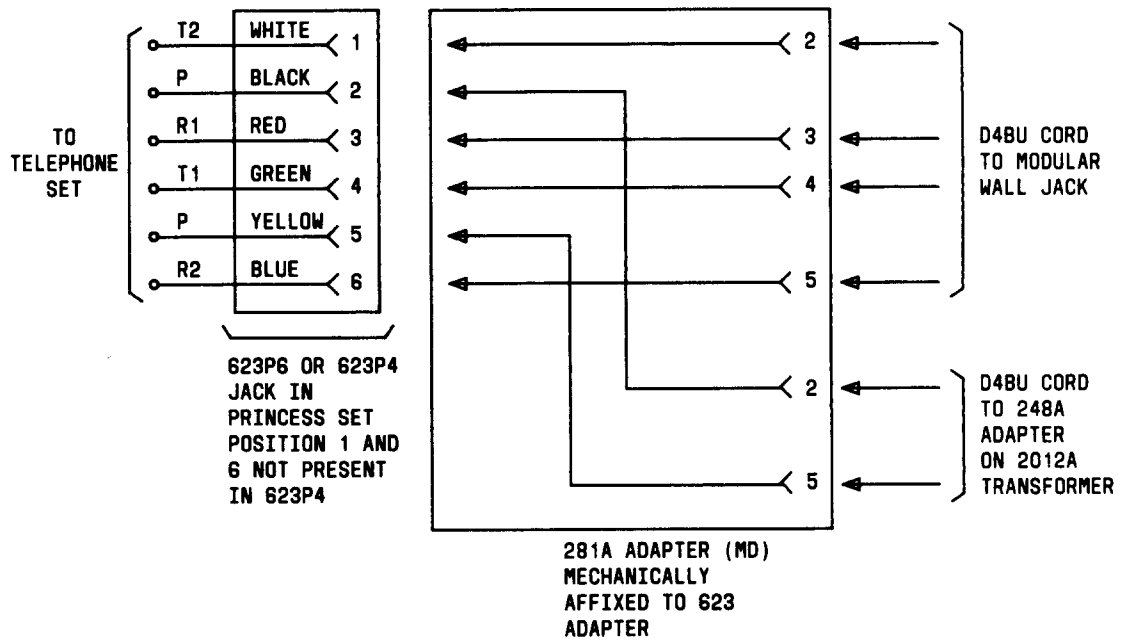

Fig. 40—Schematic Diagram, 281A (MD) Adapter

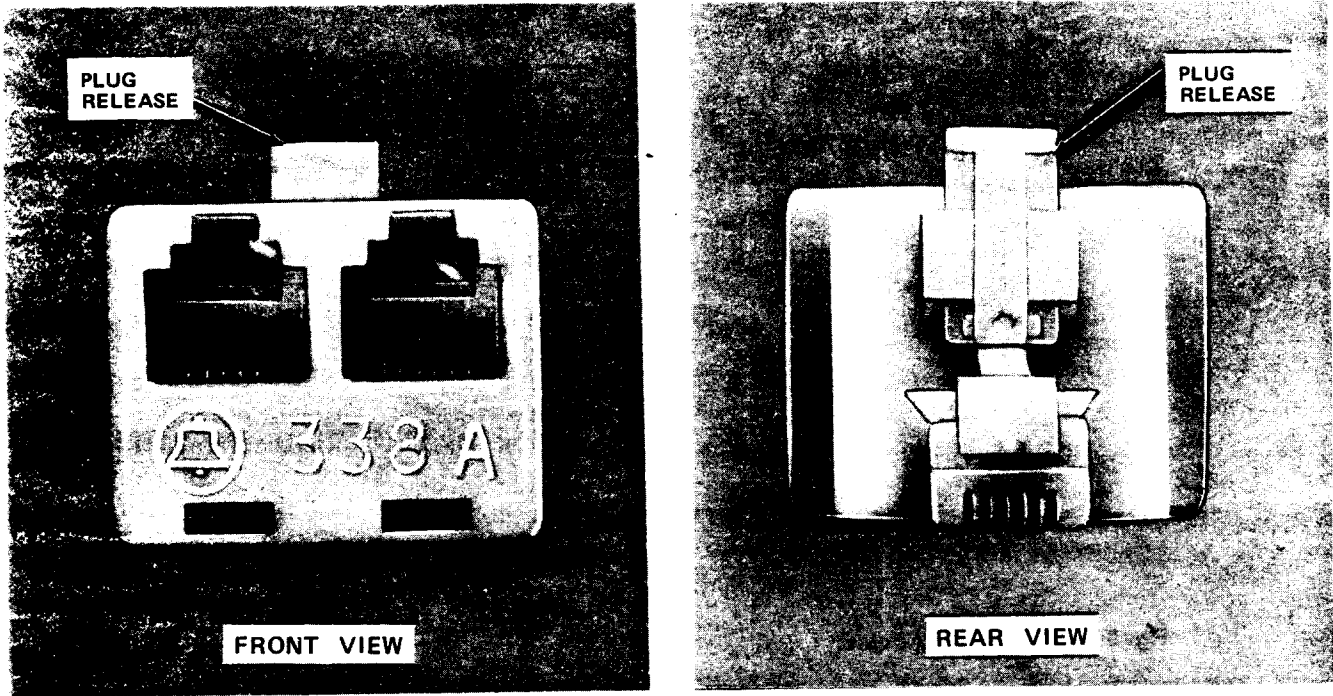

Fig. 41—338A Adapter

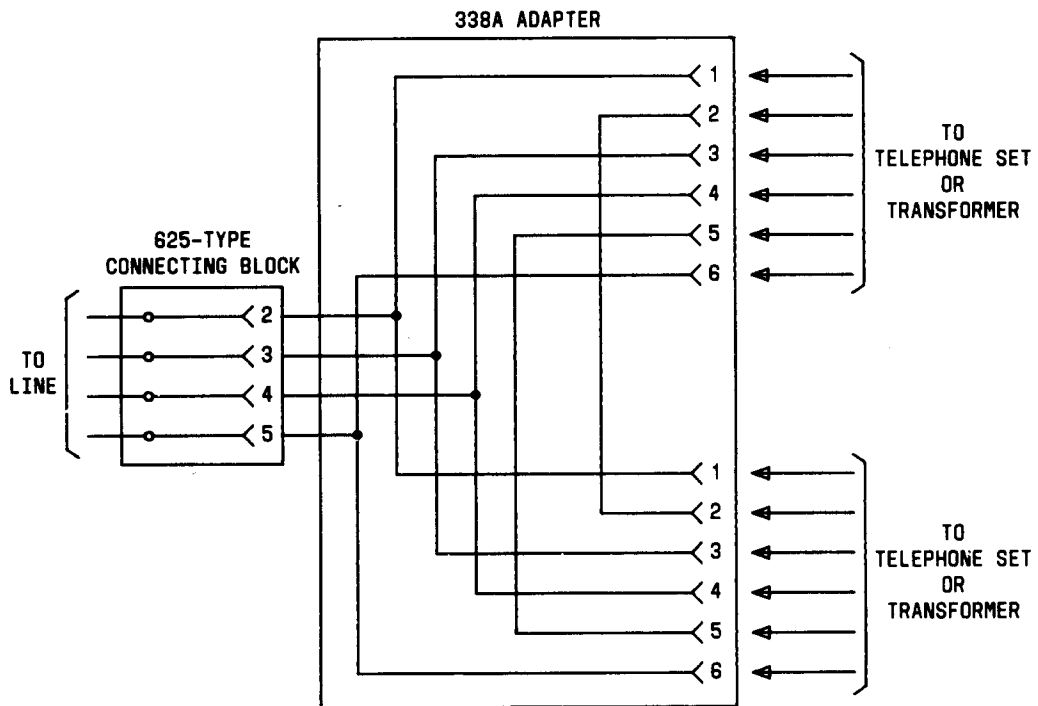

Fig. 42—Schematic Diagram, 338A Adapter

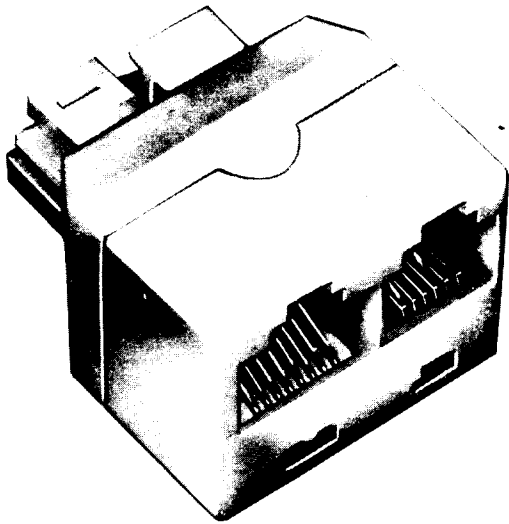

Fig. 43—400B Adapter

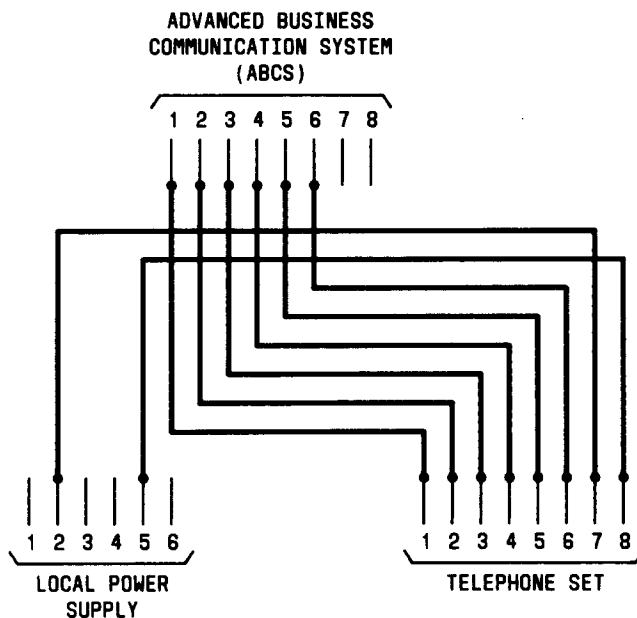

Fig. 44—Schematic Diagram, 400B Adapter

Fig. 53—KS-20202, List 1 and List 2 Housing

Fig. 54—43-Type (MD) Bracket

Fig. 55—63A (MD) Bracket

Fig. 56—63B Bracket

Fig. 57—KS-20502, List 1 (MD) Bracket

Fig. 58—KS-20502, List 2 Bracket

Fig. 59—B Mounting Bracket

Fig. 60 and 61—Assembly of B Waterproof Jack to B Outlet Box and B Mounting Bracket

Fig. 62—16-Type Faceplate

Fig. 63—65A Faceplate Assembly

Fig. 64—158A Cover.

2.50 Order as follows:

- Adapter, 224A
- Adapter, 225A
- Adapter, 267A
- Adapter, 338A
- Adapter, Jack, Female, Weatherproof, B
- Box, Outlet, B
- Bracket, 43B (MD)
- Bracket, 63A (MD)
- Bracket, 63B
- Bracket, Mounting, B
- Bracket, KS-20502, List 2
- Converter, 1A
- Cord, Weatherproof, B
- Cord, Weatherproof, C
- Cordage, Flexible, KS-15153 (3-conductor, 18-gauge) Specify length (Note 1)
- Cover, KS-19316, List 5 (cast aluminum)
- Housing, KS-19316, List 4 (cast aluminum)
- Housing, KS-19316, List 5 (cast aluminum)
- Housing, KS-19316, List 6 (cast aluminum)

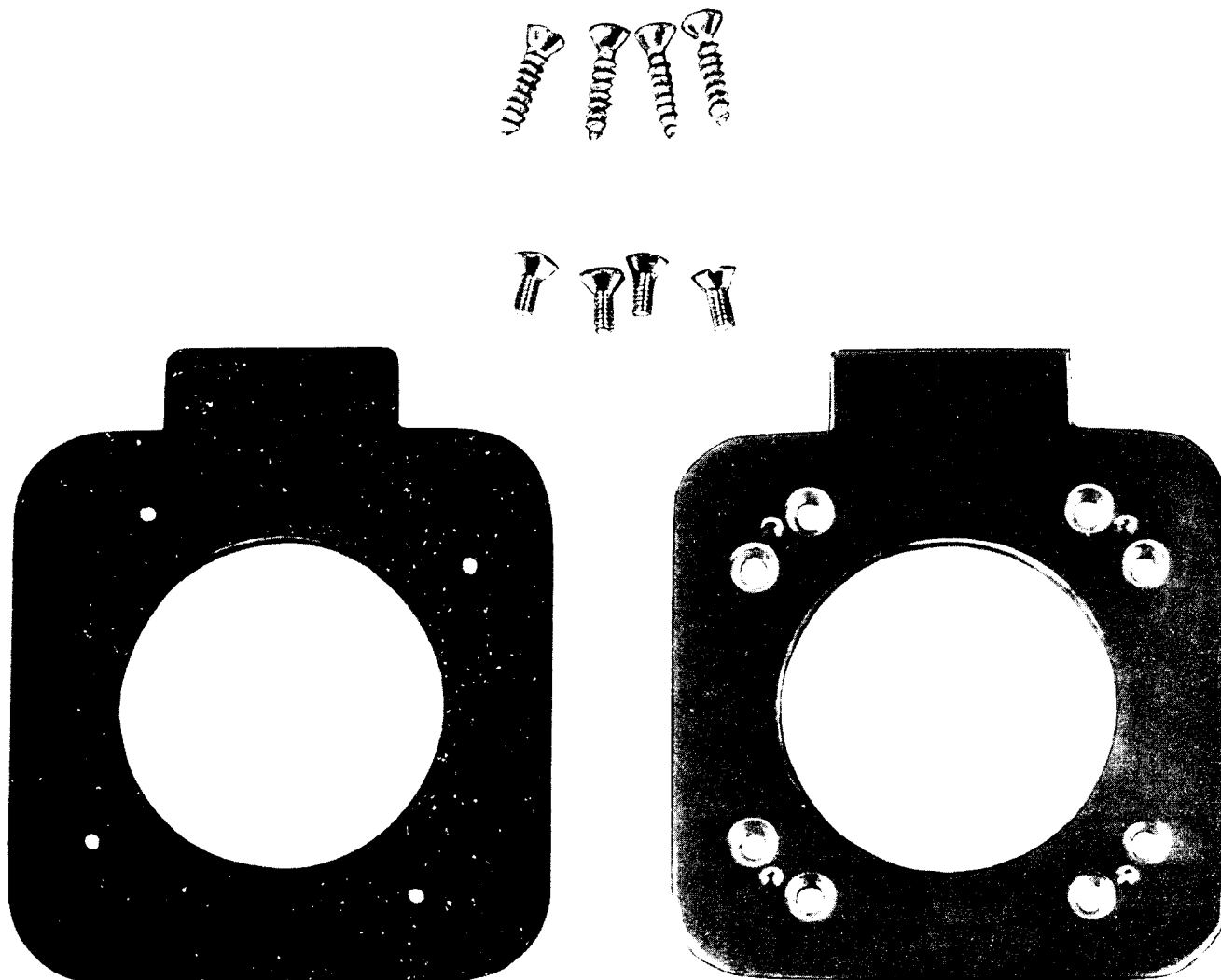

Fig. 45—AT-8731 B Adapter Plate

- Housing, KS-20202, List 1 (cast aluminum)
- Jack, 541A (MD) (Note 2)
- Jack, 547B (MD) (Note 2)
- Jack, 548A (Note 2)
- Jack, 549A (Note 2)
- Jack, 550A (Note 2)
- Jack, 551A (MD) (Note 2)
- Jack, KS-8420 (MD) (Brass)
- Jack, KS-8421 (MD) (Brass)
- Jack, Male, Weatherproof, B
- Jack, Female, Weatherproof, B
- Jack, Male, Waterproof, B
- Plate, B Adapter, AT-8731
- Plate, Face, 16A (Note 2)

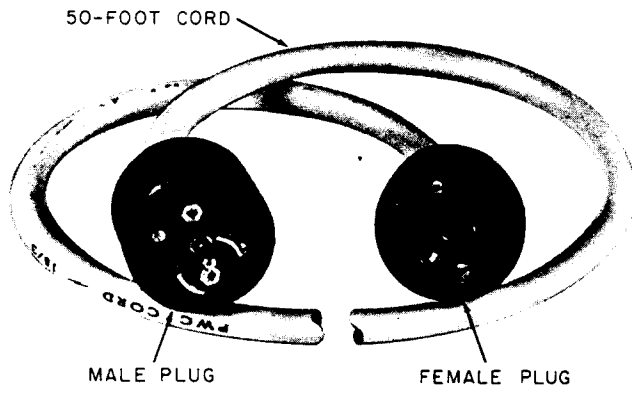

Fig. 46—B Weatherproof Cord

- Plate, Face, 16B (Note 2)
- Plate, Face, 16D (Note 2)
- Plate, Face, 65A (Note 2)
- Plug, 423A (Note 2)
- Plug, 478A (Note 2)
- Plug, 478B (Note 2)
- Plug, 504A (MD) (Note 2)
- Plug, 505A (Note 2)
- Plug, KS-8419 (MD) (Brass only)
- Template, B

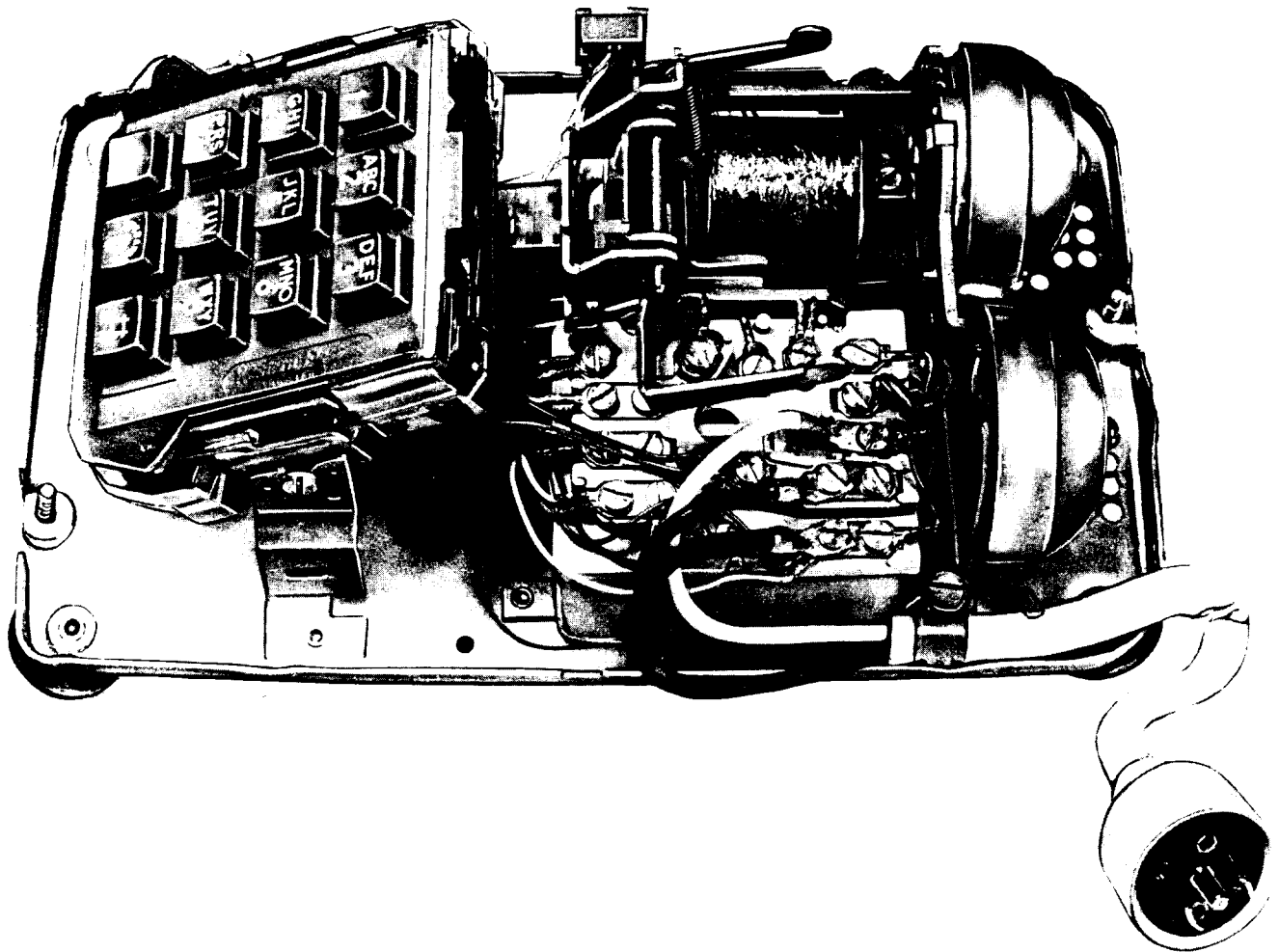

Fig. 47—C Weatherproof Cord

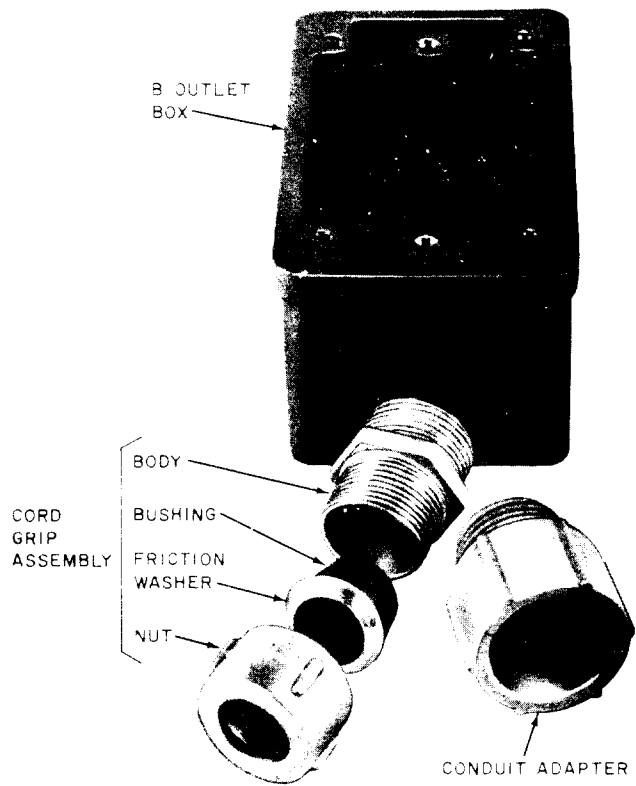

Fig. 48—B Outlet Box (for Mounting B Weatherproof Jacks)

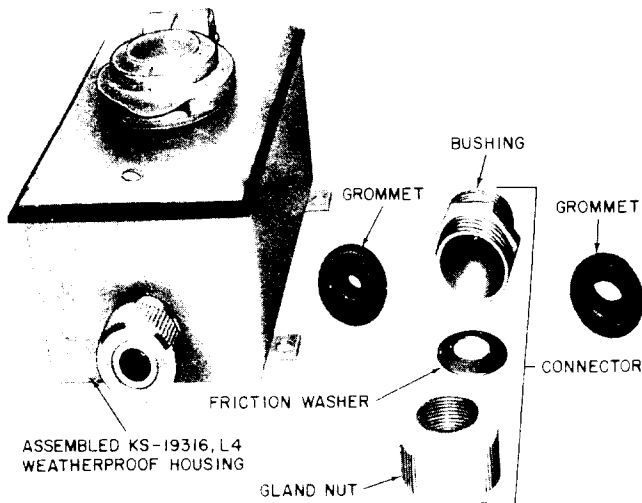
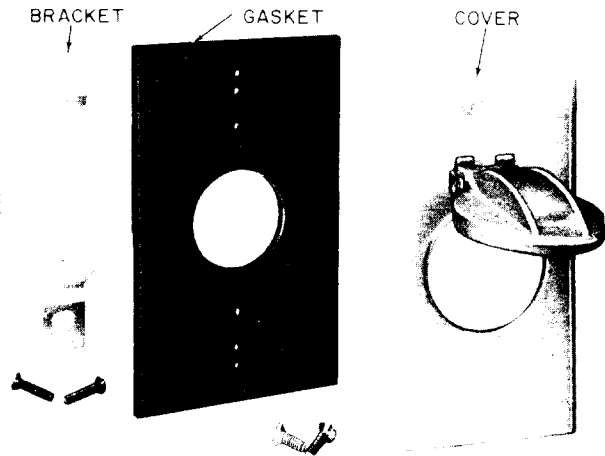

Fig. 49—KS-19316, List 4 Housing and Components (Two of Three Grommets Shown)



FOR USE WHERE BOX FOR JACK HAS BEEN INSTALLED OR REPLACEMENT PARTS FOR KS-19316, LIST 4

ACCEPTS

- 493A JACK (MD),
- 541A JACK (MD), 548A JACK,
- 625F CONNECTING BLOCK

MOUNTS TO STANDARD ELECTRICAL OUTLET BOX  
MOUNTING SCREW SUPPLIED

Fig. 50—KS-19316, List 5 Cover

- Template, C.

**Note 1:** Used with KS-8419 plug.

**Note 2:** Add color suffix, Table B or C.

2.51 Replaceable (optional) components are as follows:

- Plate, Cover, 818839490
- Plate, Cover, 818839508
- Plate, Cover, 818839540.

2.52 See Table B for color ordering information on jacks. See Table C for color ordering information on plugs.

### 3. JACKS AND JACK MOUNTINGS — INDOOR

3.01 Only one conductor shall be connected to a single clip of a clip-type jack terminal. The loop-through method for terminating inside wiring cable

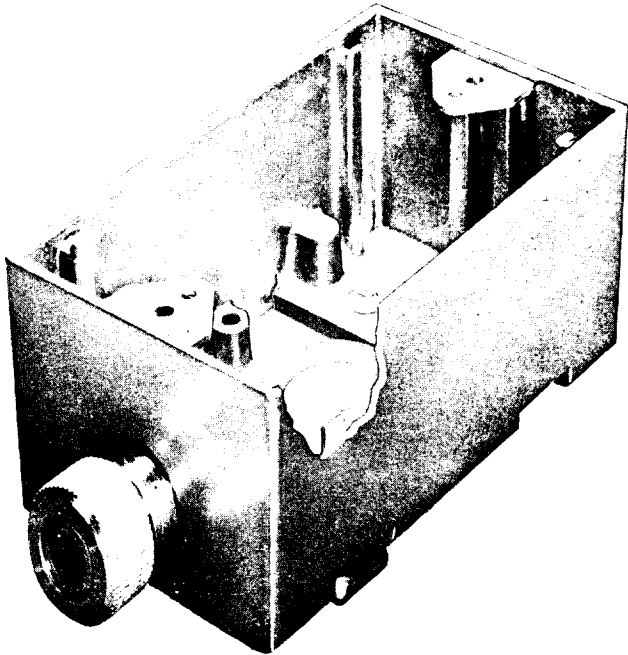

- FURNISHED WITH LATER PRODUCTIONS OF KS-19316, LIST 6 HOUSING
- WITH REVERSIBLE MOUNTING LUGS

Fig. 51—KS-19316, List 6 Housing Box

may be used on jacks which have dual clip-type terminals.

**3.02** Connect conductors as indicated by the color designators stamped next to the terminals. The red conductor is terminated at the R terminal, etc. Table D shows the connections for 4-conductor jacks.

**3.03** Table E shows the connections for 8- and 12-conductor jacks.

**A. Installation of Nonflush Jacks**

**3.04** Install 404B (MD) and 549A jacks as follows:

- (1) Connect station wire to jack and dress wiring inside shell.
- (2) Fasten jack to mounting surface with furnished screws.

**3.05** Install 551A jack as follows:

- (1) Connect station wire or cable conductors to clip terminals of jack using 714-type tool. Conductors may be loop-through terminated.
- (2) Fasten jack to mounting surface with furnished screws.

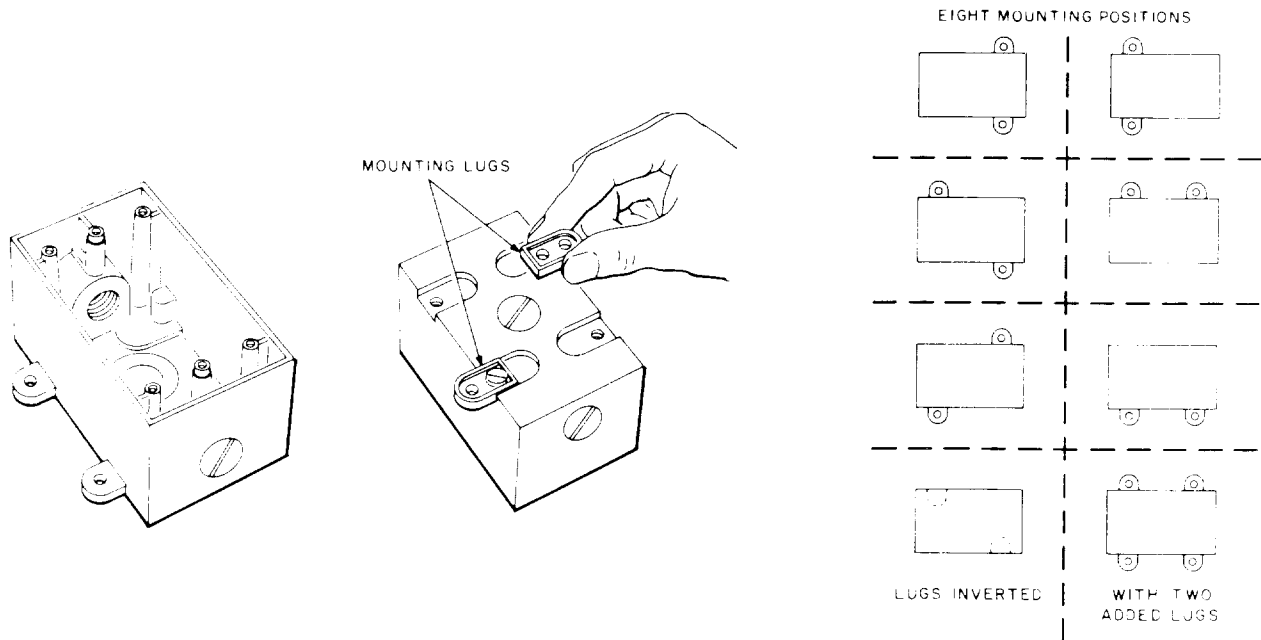

Fig. 52—KS-19316, List 6 Housing Box Showing Reversible Mounting Lugs

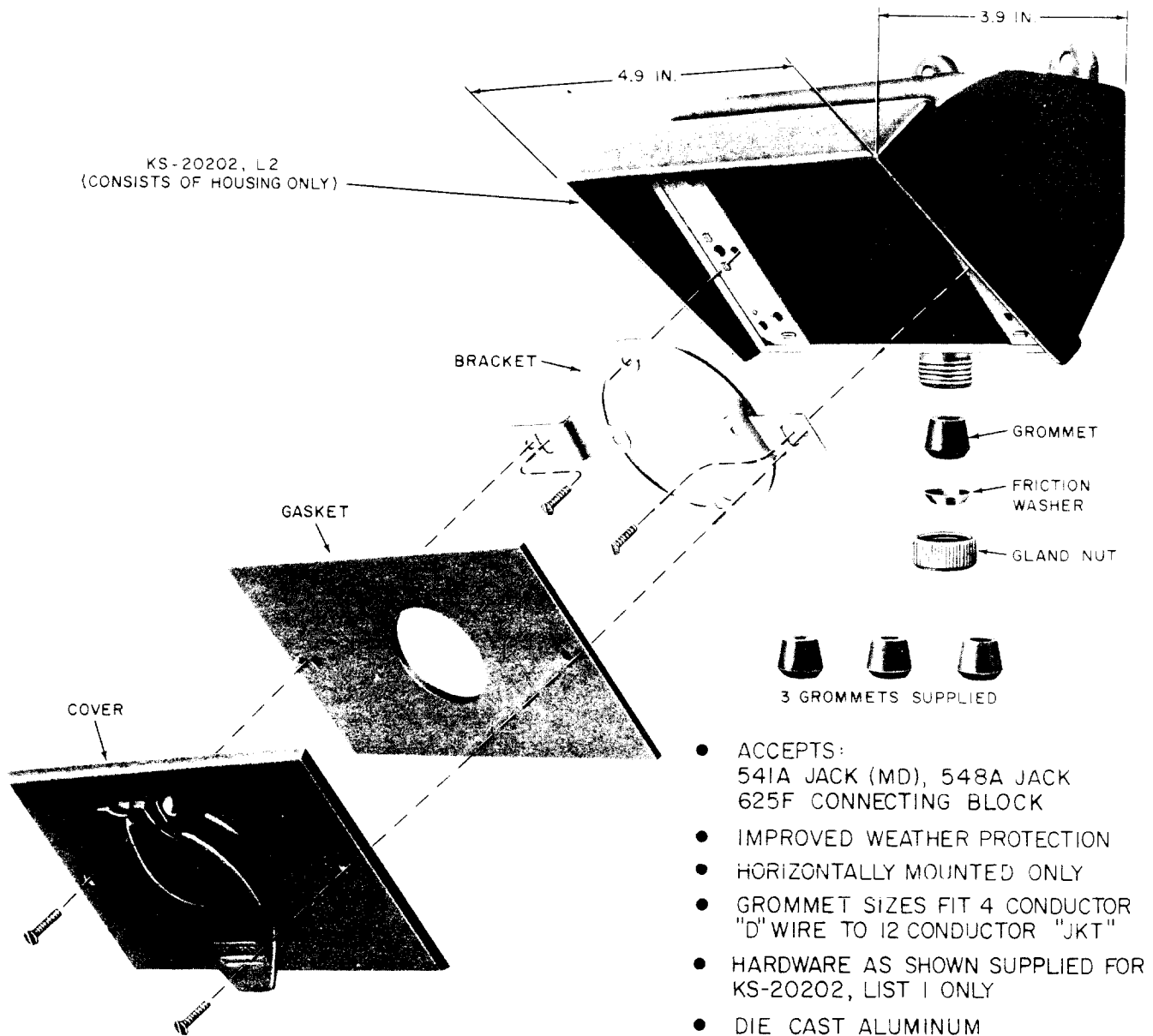

Fig. 53—♦Assembly of KS-20202, Lists 1 and 2 Weatherproof Housing♦

**B. Installation of Flush-Type Jacks in Standard Electrical Outlet Boxes**

**3.06** Install 497A (MD) jack as follows:

- (1) Mount 493A (MD) jack on 43A bracket.
- (2) Connect station wire to jack.

(3) Mount jack-equipped bracket in outlet box.

(4) Fasten faceplate with furnished screws.

**3.07** Install 547-type (MD) jack as follows:

- (1) ♦Attach 541A (MD) jack on 43B bracket.♦
- (2) Connect station wire or cable to jack.



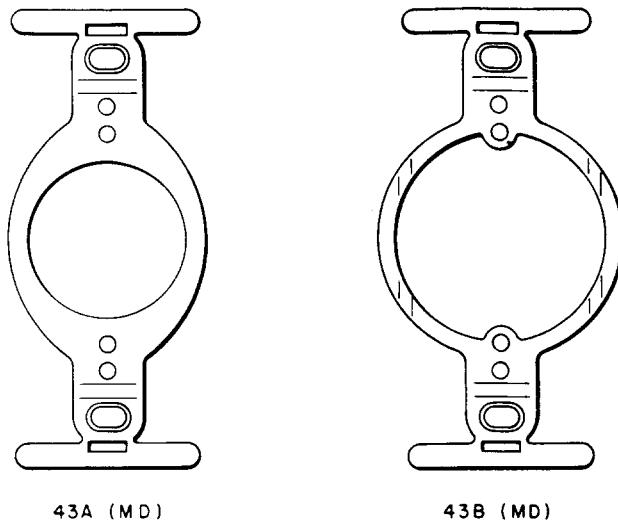

43A (MD)

43B (MD)

- TO MOUNT JACKS IN STANDARD ELECTRICAL OUTLET BOX
- BREAK-OFF WINGS
- REPLACED BY 43B BRACKET
- TO MOUNT
  - 493A JACK (MD)
  - 548A JACK
- COMPONENT OF
  - 497A JACK (MD)
  - 550A JACK (OLD)
- TO MOUNT
  - 493A JACK (MD)
  - 541A JACK (MD)
  - 548A JACK
  - 625F CONNECTING BLOCK
  - REPLACES 43A BRACKET (MD)
- COMPONENT OF
  - 547B JACK (MD)
  - 550A JACK
  - 625B CONNECTING BLOCK

Fig. 54—43-Type (MD) Bracket

- (3) Mount jack and bracket assembly in outlet box.
- (4) Install faceplate. (The cover must be on jack before placing faceplate.)

**3.08** Install 493A (MD) or 548A jack as follows:

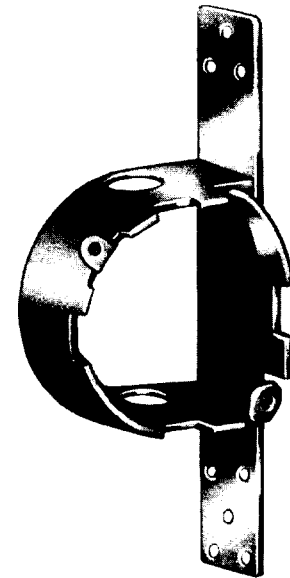

Fig. 55—63A (MD) Bracket

- USE TO PREWIRE BUILDING DURING CONSTRUCTION
- MOUNTED TO STUDDING
- USE WITH 16-TYPE FACEPLATE
- FOR MOUNTING
  - 493A JACK (MD)
  - 541A JACK (MD)
  - 548A JACK
  - 625F CONNECTING BLOCK

- (1) Attach jack to 43-type bracket (MD) (Fig. 54) or to the bracket supplied with the 65A faceplate.
- (2) Connect station wire or cable to jack.
- (3) Attach bracket to outlet box and install suitable faceplate.

**3.09** The 550A jack is assembled in the same manner as the 497A (MD) jack. It consists of a 548A jack, 65A faceplate, and mounting screws.

#### C. Installation of Flush-Type Jacks in 63-Type or KS-20502 Type Bracket

**3.10** The 493A (MD), 541A (MD), and 548A jacks can be mounted on 63-type or KS-20502 type

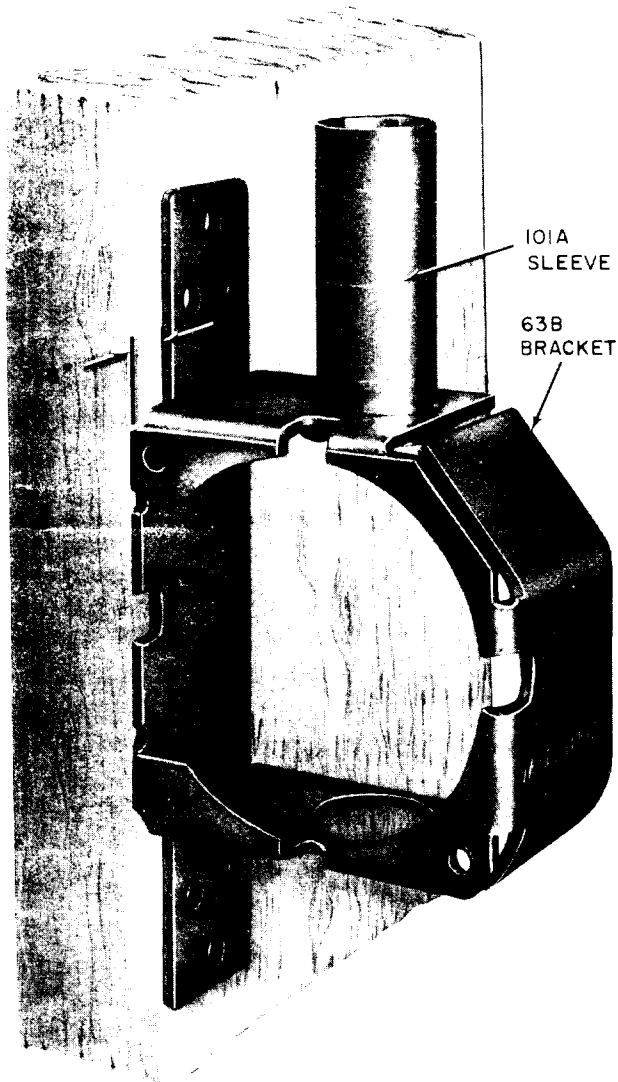

Fig. 56—63B Bracket With 101A Sleeve Installed

bracket (Fig. 55, 56, 57, and 58) with a 16-type or 65A faceplate. Use the same color faceplate as the jack.

**3.11** When mounting jacks on the 63-type bracket, the 16-type faceplate ring retainer is required. The 16-type or 65A faceplate can be mounted to the KS-20502 type bracket without a ring retainer.

(a) The 493A (MD) or 548A jack is installed on the 63-type bracket as follows:

- (1) Mount the ring retainer on bracket.

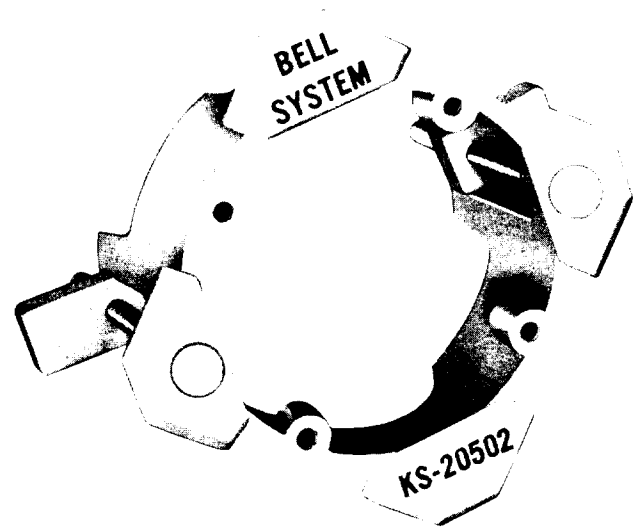

- SELF-EXTINGUISHING PLASTIC
- USE FOR EXISTING WALLS
- WALL HOLE 2-1/4 INCH DIAMETER
- WALL THICKNESS LIMIT 1-1/4 INCH

Fig. 57—KS-20502, List 1 (MD) Bracket

- (2) Connect station wire to jack.
  - (3) Mount jack on ring retainer.
  - (4) Mount faceplate on ring retainer.
- (b) The 493A (MD) or 548A jack is installed on the KS-20502 type bracket as follows:

- (1) Connect station wire to jack.
- (2) Mount jack on bracket using screws supplied with bracket.
- (3) Mount faceplate to bracket using screws supplied with bracket.

**3.12** The KS-20502, List 2 plastic bracket (Fig. 58) is a replacement for the KS-20502, List 1 (MD) plastic bracket (Fig. 57). This bracket is intended to mount the 541A (MD) or 548A jack, the 625F connecting block, and 16-type or 65A faceplate.

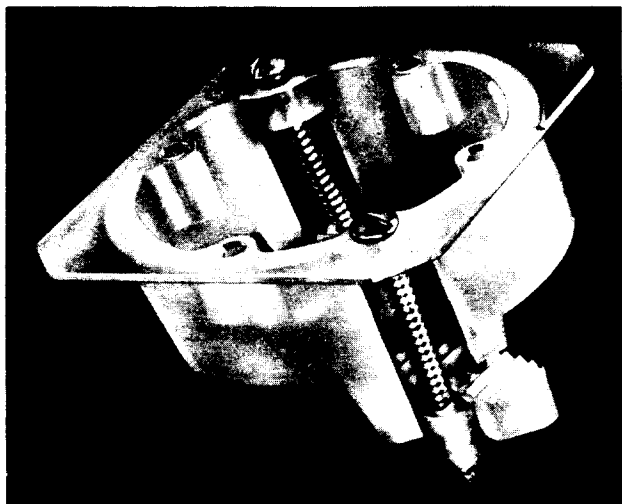

- PLASTIC BRACKET. REPLACEMENT FOR STEEL KS-19407, LI BRACKET AND PLASTIC KS-20502, LI BRACKET
- FOR EXISTING WALLS (POST WIRING)
- FOR MOUNTING
  - 541A (MD) JACK
  - 548A JACK
  - 625F CONNECTING BLOCK
  - 16-TYPE FACEPLATE
- WALL HOLE 2-1/4 INCH DIAMETER
- WALL THICKNESS LIMIT 1-1/4 INCHES

**Fig. 58—KS-20502, List 2 Bracket**

**3.13** This bracket may be installed in a 2-1/4 inch diameter hole with a wall thickness of 1-1/4 inch maximum as follows:

- (1) Make sure the wall behind the bracket is hollow.
- (2) Fasten bracket in wall opening by first placing the self-aligning clamps behind interwall material and tightening the two screws.
- (3) Bring concealed building wire through opening of bracket and make connections to 541A (MD) or 548A jack.
- (4) Position jack and faceplate on bracket so two screw holes opposite each other align. Fasten jack and faceplate to bracket using two screws fur-

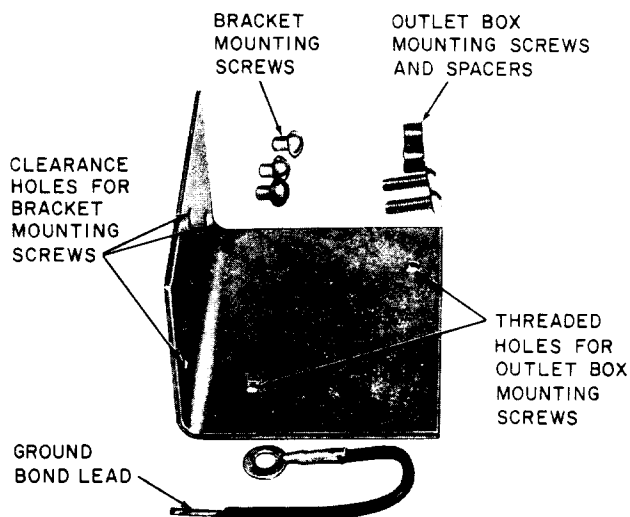

**Fig. 59—B Mounting Bracket (for Mounting B Outlet Box)**

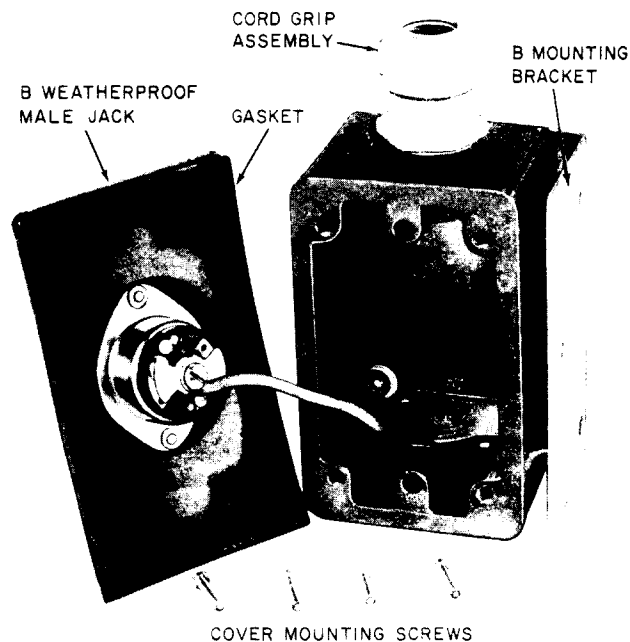

**Fig. 60—B Weatherproof Male (or Female) Jack on B Outlet Box Showing Ground Lead Connected to B Mounting Bracket**

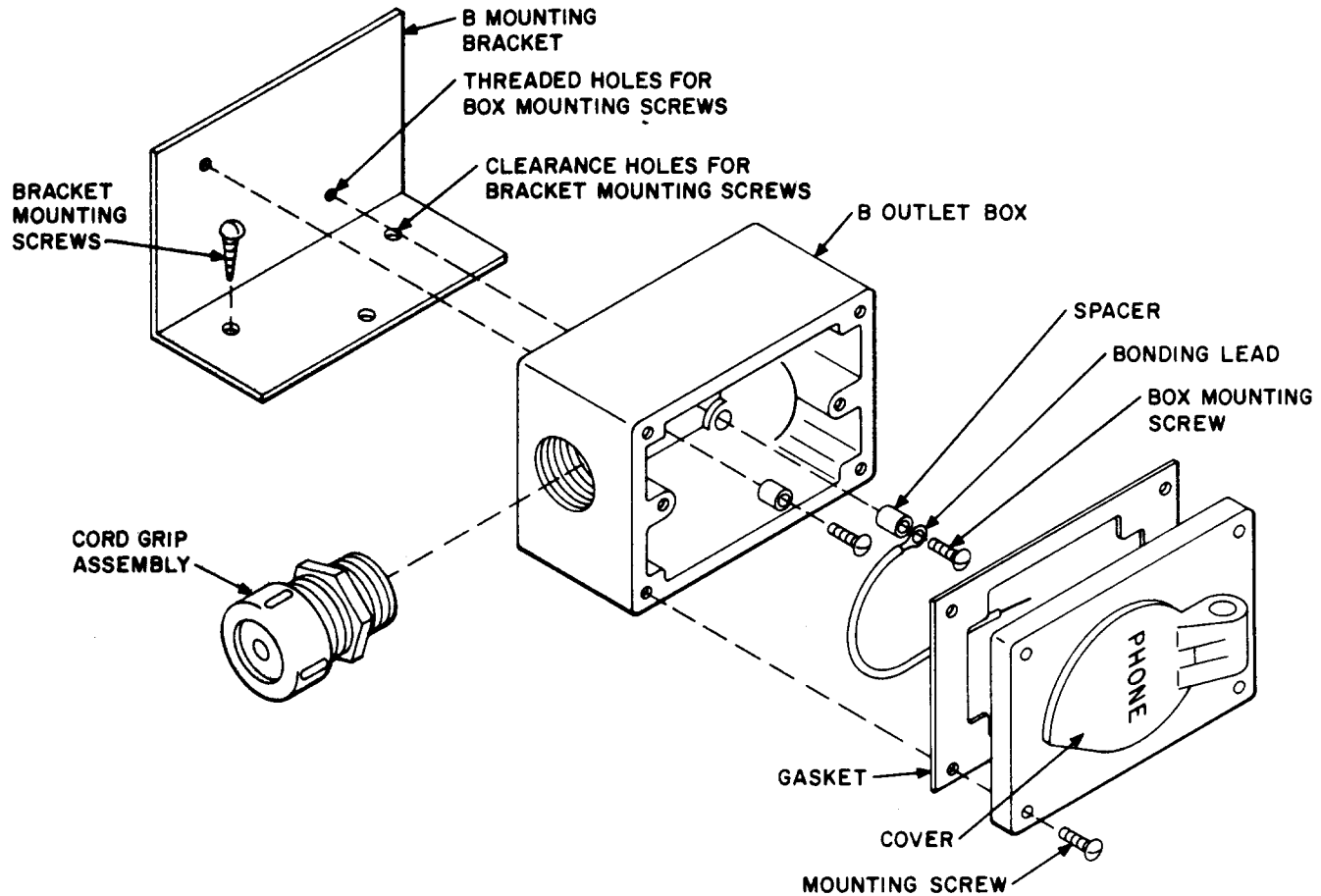

**Fig. 61—Assembly of B Weatherproof Male Jack to B Outlet Box and B Mounting Bracket**

nished with bracket. These are special thread-cutting screws. The use of any other screws could overstress the polycarbonate bracket and seriously affect the life of the bracket.

**3.14** The 541A (MD) jack is installed in the 63-type bracket as follows:

- (1) Mount ring retainer on 63-type bracket.
- (2) Connect station wire or cable leads to clip terminals of jack.
- (3) Mount jack on ring retainer.
- (4) Place cover on jack.
- (5) Mount faceplate on retainer ring.

**3.15** The 541A (MD) jack is installed in the KS-20502 type bracket as follows:

- (1) Connect station wire or cable leads to clip terminals of jack.
- (2) Place cover on jack.
- (3) Position faceplate over cover and fasten faceplate and jack to bracket.

#### **4. JACKS AND JACK MOUNTINGS — OUTDOOR**

**4.01** For a 4-conductor jack, connect conductor as indicated by the color designator stamped next to the terminals. The red conductor is terminated at the R terminal, etc.

**4.02** Install KS-8420 (MD) jack as follows:

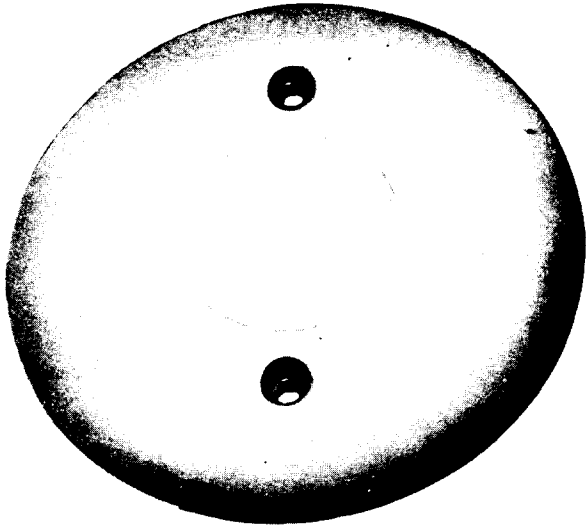

16A

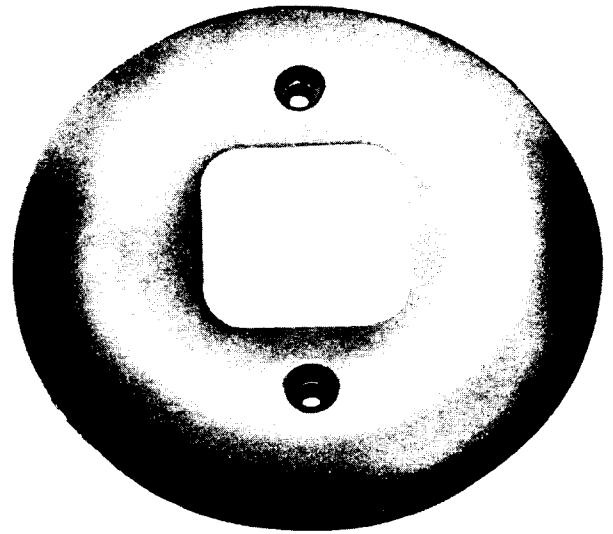

16B

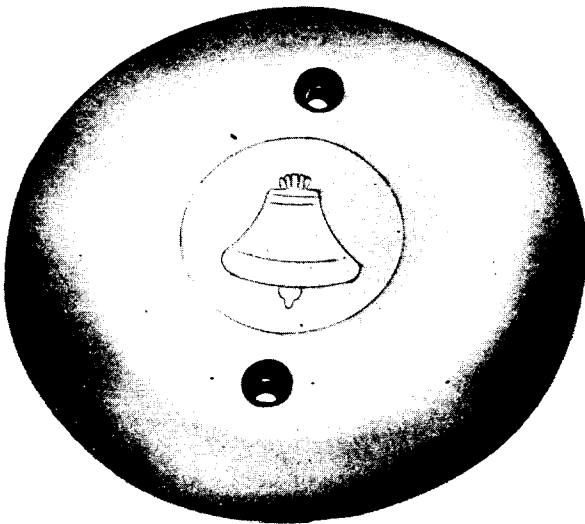

16D

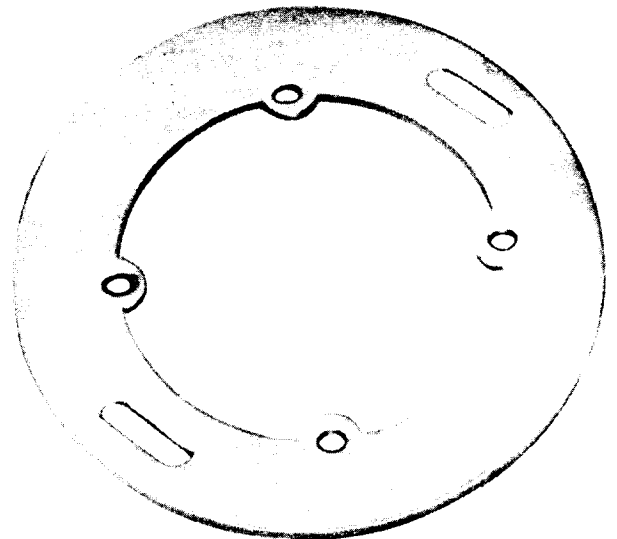

RING RETAINER

- MOUNTS TO 63-TYPE BRACKET USING RING RETAINER KS-20502, LIST 2 BRACKET (RING NOT REQUIRED)
- MOUNTING SCREWS AND RING RETAINER SUPPLIED

Fig. 62—16-Type Faceplate

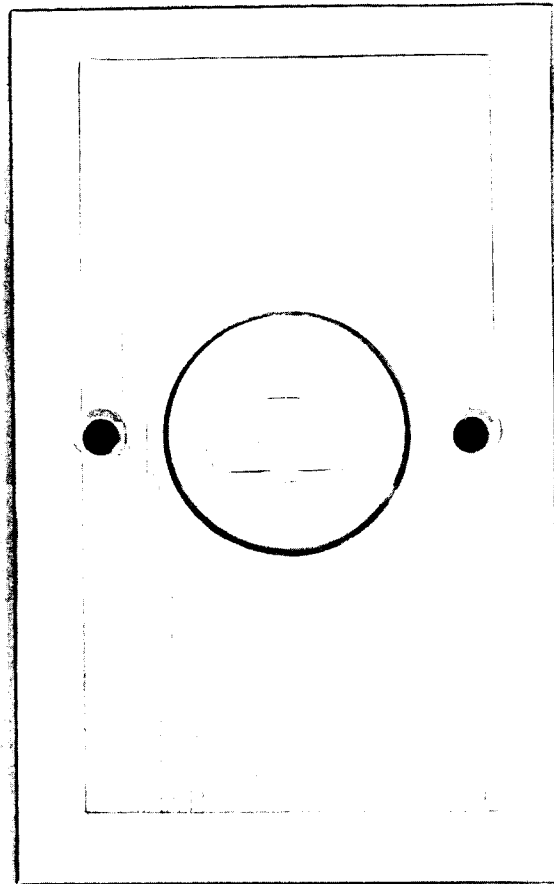
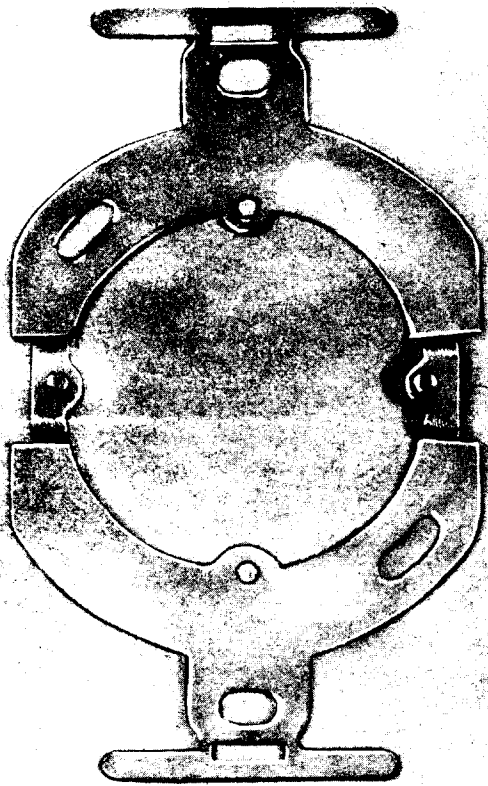

**Fig. 63—65A Faceplate Assembly**

- (1) Arrange for the customer to provide a 2-11/16 inch hole at location selected for jack installation.
  - (2) Temporarily insert jack in hole and mark fastener holes.
  - (3) Remove jack and drill fastener holes.
  - (4) Connect wire as shown in Fig. 12.
  - (5) Secure jack to mounting surface with four No. 8 pan head or flathead cadmium plated tapping screws.
- 4.03** Install KS-8421 (MD) jack as follows:
- (1) Arrange drop wire or bridle wire and conduit at location selected for installation (Fig. 13).
  - (2) Secure the jack housing to the mounting surface using suitable fasteners.
  - (3) Connect wire to terminal block as shown in Fig. 12.
  - (4) Mount terminal block to jack housing.
  - (5) Install cover on housing.
- 4.04** Install KS-19316, List 4 or 6 housing as follows:

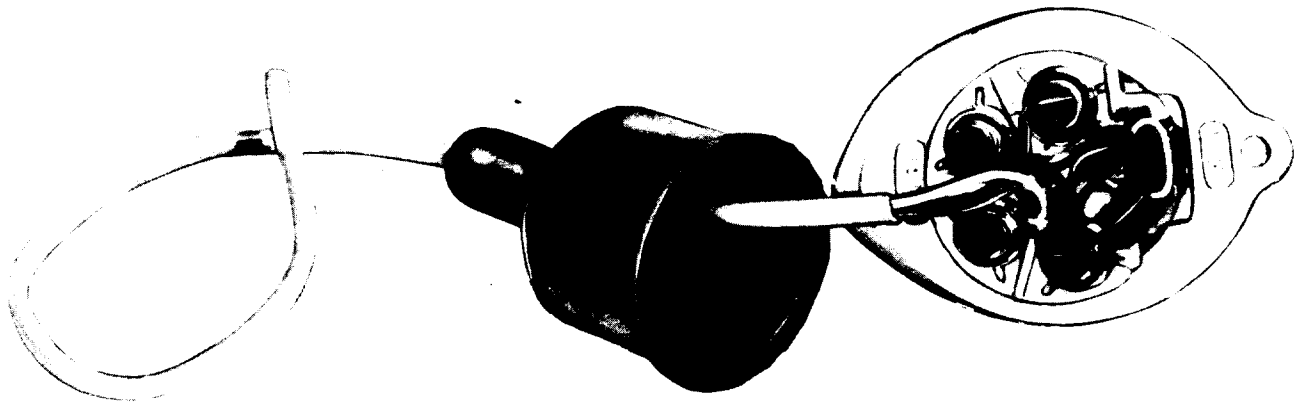

Fig. 64—158A Cover

- (1) Arrange cable at location selected for jack installation.
  - (2) Use housing box with positioned mounting lugs to mark lug mounting holes (Fig. 52).
  - (3) Drill holes and secure housing box to mounting surface with No. 8 pan head or flathead cadmium plated tapping screws.
  - (4) Place gland nut, friction washer, and grommet on cable.
  - (5) Run cable inside housing and adjust grommet and friction washer for watertight fit with gland nut.
  - (6) Attach bracket to housing box.
  - (7) Connect wire or cable to jack.
  - (8) Install jack to bracket. The cover supplied for the 541A (MD) jack is not required and may be discarded.
  - (9) Install gasket and cover for watertight fit.
- 4.05** Install KS-20202, List 1 housing (Fig. 53) as follows:
- (1) Arrange cable or drop wire at location selected for installation.
  - (2) Hold housing to mounting surface and mark fastener holes.
  - (3) Remove housing and drill fastener holes.
  - (4) Secure housing to mounting surface with No. 8 pan head or flathead cadmium plated tapping screws.
  - (5) Place gland nut, friction washer, and grommet onto cable or drop wire.
  - (6) Run cable or drop wire inside housing and adjust grommet and friction washer for watertight fit with gland nut.
  - (7) Install bracket and arrange cable or drop wire through center of bracket.
  - (8) Connect conductors to selected jack.
  - (9) Install jack to bracket. The cover supplied for the 541A (MD) jack is not required and may be discarded.
  - (10) Install gasket and cover.
- 4.06 B Weatherproof Jack Adapter:** Mount the B weatherproof female jack adapter (Fig. 29 and 30) on an existing KS-8421 (MD) jack housing after the old jack and coverplate are removed. Use the four mounting screws and cover gasket provided. Three screw terminals stamped T, R, and GR provide for connection to tip, ring, and ground. Wire tip and ring of jack to the tip and ring terminals of the protector. Connect a 14-gauge ground wire from ground terminal of protector to center ground terminal of jack.

TABLE B4

## COLOR ORDERING GUIDE—JACKS

JACK AND FACEPLATE	LIGHT OLIVE GRAY (-49)	IVORY (-50)	BROWN (-54)
541A (MD)	●	●	●
547B (MD)	●*	●*	●*
548A	—	●	—
549A	—	●	—
550A	—	●*	—
551A (MD)	●	●	—
16A	●	●	●
16B	●	●	●
16D	●	●	●
65A	●	●	●

\* Additional faceplates in colors corresponding to jack.

**Note:** Do not bond ground wire to boat ground as undesirable electrolysis reaction may develop.

**4.07 DANGER:** Before making contact with any metal portion of a recreational vehicle in paragraphs 4.08 and 4.09, check for the presence of hazardous voltage on the body or chassis using rubber gloves and B voltage tester.

**4.08 C Template:** The C template (not shown) is used on the recreational vehicle to locate pilot holes for the three thread-cutting screws used to mount the B mounting bracket. It is printed on index card stock and packed separately from the B mounting bracket so mounting holes may be prepared by the vehicle owner prior to bracket installation.

**4.09 B Weatherproof Jacks:** The B weatherproof male or female jacks (Fig. 14, 15, and 16)

TABLE C

## COLOR ORDERING GUIDE—PLUGS

COLOR		TYPE PLUG				
		423A (NOTE)	478A	478B	504A (MD)	505A (MD)
Black	-03		●			
Light Olive Gray	-49				*	*
Ivory	-50		●	●	*	●
Green	-51					
Red	-53					
Brown	-54					
Yellow	-56					
White	-58		●			
Rose Pink	-59					
Light Beige	-60					
Light Gray	-61					
Aqua Blue	-62					
Turquoise	-64					

**Note:** This plug is inside the 750 telephone set and may be any color as it is made from scrap plastic.

\* Manufacture discontinued.



**TABLE D**  
**CONNECTIONS TO 4-PIN JACKS**

INSIDE WIRE	4-PIN JACK
(G) Tip	G
(R) Ring	R
(Y) Ground and/or Transformer	Y
(B) Transformer	B

**TABLE E**  
**CONNECTIONS TO 8- AND 12-PIN JACKS**

INSIDE WIRE QUAD		D AND E INSIDE WIRING CABLE	NO. TERMINALS	
			8	1
		TERMINAL DESIGNATIONS		
First	Red	BL-W	R	1
	Green	W-BL	G	2
	Yellow	O-W	Y	3
	Black	W-O	BK	4
Second	Red	G-W	W	5
	Green	W-G	R-R	6
	Yellow	BR-W	Y-Y	7
	Black	W-BR	BK-BK	8
Third	Red	S-W		9
	Green	W-S		10
	Yellow	BL-R		11
	Black	R-BL		12

are mounted in the B outlet box using the four mounting screws and cover gasket provided. Three screw terminals stamped T, R, and GR are provided for connections. A cord grip assembly and conduit adapter are provided with the B outlet box for use with service wire or plastic conduit. Mount as follows:

- (a) Mount the B weatherproof female jack and B outlet box close to the protector on the post at the utility pad and provide a ringer simulator if required. Wire tip and ring of jack to tip and ring terminals of protector. Connect a 12-gauge ground wire from ground terminal of protector to center ground terminal jack. (See Note in paragraph 4.06.)

- (b) The B mounting bracket is used to mount the B weatherproof male jack and B outlet box on the recreational vehicle using the mounting holes provided by the customer. The customer will use the C template to drill pilot holes for the B mounting bracket on top of the trailer hitch or vehicle bumper. The cord grip assembly may be attached to either end of the B outlet box depending on existing space. Wire tip and ring of jack to tip and ring terminals of connecting block in the vehicle. The ground lead provided with the B mounting bracket must be connected from center ground terminal of the jack to a mounting screw as shown in Fig. 60 and 61 to provide a ground bond to vehicle chassis.

**4.10 Waterproof Male Jack:** The B waterproof male jack (Fig. 17 and 18) is mounted on a boat using mounting holes provided by the customer. The customer will use the B template to locate the pilot holes for mounting screws and clearance hole for the jack body for the B waterproof male jack. The jack is chrome-plated with a hinged, threaded cover which makes the jack waterproof when not in use. Three screw terminals, stamped T, R, and GR, on the rear of the jack provide connection for ring, tip, and ground. Wire the tip and ring of the jack to tip and ring terminals of connecting block on boat.

**Note:** Do not bond ground wire to boat ground as undesirable electrolysis reaction may develop. Insulate and store ground conductor. Refer to Section 461-220-101 for routing wiring in boats.

**4.11 Assembly of B Weatherproof Jack to Outlet Box:** The B weatherproof male jack mounts in the B outlet box on the B mounting bracket as shown in Fig. 61. The B weatherproof male and female jack both use the B outlet box but the mounting bracket is used only on the vehicle, which is always the male jack.

**4.12 652WP4 Jack:** The 652WP4 jack can be used with all existing outdoor boxes or housing. A 3/4-inch No. 14 straight pipe thread is moulded on the rear of the jack permitting it to be mounted on the box or housing using a 3/4-inch conduit lock-nut (not supplied). The modular jack is effectively sealed from environmental effects with or without a modular plug installed. Without a plug installed, the jack opening is sealed by the spring-loaded, gasketed cover. To provide a seal with a modular plug inserted,

the rubber grommet, plastic washer, and screw cap must be assembled on the cord as shown in Fig. 20. After the plug is inserted in the jack, the screw cap is threaded and tightened on the threaded projection moulded on the jack frame.

**5. PLUGS — INDOOR AND OUTDOOR (TABLE F)**

**5.01 ♦504A (MD) Plug:** Included with the 504A (MD) plug (Fig. 23 and 24) is a metal cord stay designed for use with cords equipped with a wire S hook. The S hook is removed and discarded. The cord stay, inserted into the vacated band hole, serves as a wing band.

**5.02** Assemble the 504A (MD) plug as follows:

- (1) Place cord tip guide on block.
- (2) Insert mounting cord tips into socket-type terminals of plug.

**Note:** For mounting cord conductor connections, refer to connection section for the telephone set.

- (3) Dress conductors so they will lie within the cap of plug.
- (4) Place wing band or cord stay of mounting cord in its proper slot.

(5) Place cap on plug so cord and wing band or cord stay will seat properly. Be sure no leads are pinched.

(6) Snap two sections of neck together.

(7) Insert screw and tighten.♦

**5.03 ♦505A (MD) Plug:** The 505A (MD) plug is a 4-contact plug similar to the 504A (MD) plug; in addition, however, it has a cord fastener which holds the cord in place while spade tips are being connected. The cord fastener also anchors the mounting cord in the assembled plug.♦

**5.04** ♦Connect current model D3BU or D4BP mounting cord to a current model 505A (MD) plug as follows:

- (1) Position flat eyelet stay band in the cord channel so the screw hole is over the screw hole in the center of the cord tip guide (Fig. 26).
- (2) Fit cord fastener into groove in the cord channel and press until it snaps into position.
- (3) Connect the mounting cord space tips in the socket-type terminals.
- (4) Insert screw through hole in block and stay band.
- (5) Dress conductors so they will not obstruct the center of the cord tip guide.

♦TABLE F♦

**PLUGS**

TYPE	NUMBER OF CONTACTS	FIGURE NUMBER	ASSOCIATED JACKS
KS-8419 (MD)	3	28	KS-8420 (MD) KS-8421 (MD)
505A (MD)	4	25, 26, 27	404B (MD), 493A (MD), 497A (MD), 548A, 549A, 550A,
423A		21	814450550 mounting block and screw assembly
	8	—	
504A (MD)	12	23	541A (MD), 551A (MD), 547B (MD)
478A, 478B	2	22	476A, 517A

- (6) Position cap assembly on cord tip guide and block; check that no cord leads are pinched and tighten screw.◆

**5.05** ◆**Caution: When cutting the stay band, take precautions to prevent the severed end from striking personnel or apparatus. Cut flat eyelet stay band approximately 1/8 inch from end of cord jacket using 8-inch sidecutters, or equivalent (Fig. 27).** Connect current model D3BU or D4BP mounting cord to an early model 505A (MD) plug as follows:

- (1) Make a right angle bend in the remaining length of stay band in the direction away from the cord conductors.
- (2) Position the mounting cord into the cord channel of the block, as shown in Fig. 27.
- (3) Fit the cord fastener into the groove in the cord channel and press until it snaps into position.
- (4) Connect the mounting cord spade tips in the socket-type terminals.
- (5) Dress the conductors so they will not obstruct the center of the cord tip guide.
- (6) Position the cap assembly on the block so the right-angle bend of the stay band is supported by the inner surface of the cap assembly; check that no cord leads are pinched.
- (7) Insert cover screw and tighten.◆

**5.06** ◆Connect 505A (MD) plug to a cord equipped with a wing band as follows:

- (1) Fit the cord tip guide into place on the top of the block.
- (2) Position the mounting cord into the cord channel of the block so the cord wing band fits into the wing band slot. One ear of the wing band will extend into the wing band slot of the cord fastener.
- (3) Fit the cord fastener into the groove in the cord channel and press until it snaps into position.
- (4) Arrange the mounting cord spade tips in the socket-type terminals.

- (5) Adjust the conductors so they will not obstruct the center of the cord tip guide.◆

**5.07 423A Plug:** Connect the 423A plug as follows:

- (1) Connect as indicated by color designations stamped adjacent to terminals.
- (2) Lay jacketed portion of cord in the two molded U-shaped projections.
- (3) Place cover on base and tighten screw.

**5.08 KS-8419 (MD) Plug:** The KS-8419 (MD) plug (Fig. 28) is a 3-contact, brass plug intended for connecting telephone sets installed on boats, trains, or auto trailers to outdoor jacks of PBX or CO lines. This plug is intended for use with KS-8420 (MD) or KS-8421 (MD) jacks.

**5.09** Connect the KS-8419 (MD) plug as follows:

- (1) Plug components are assembled to KS-15143 3-conductor, 18-gauge cord, or equivalent (Fig. 28).
- (2) In KS-15143 cord, or equivalent, the black conductor should be used for the ring (negative) side of the line. The white conductor should be used for tip (positive) side of the line. The green conductor is the ground conductor.
- (3) One terminal of the KS-8419 (MD) plug has a small lug protruding from the contact. This lug and the notched terminal on KS-8420 (MD) and KS-8421 (MD) jacks are provided to ensure that the plug is inserted in one position only.
- (4) When ground is necessary for service, the green conductor should be terminated on the notched terminal.

## 6. ADAPTERS

**6.01** **Caution: Because of the possibility of installing more than one transformer on the same inside wiring pair, the 267A (MD) and the 267A2 adapters should not be used to connect dial illumination transformers to modular systems (use the 338A adapter instead).** Adapters are intended for use where it is not desirable to replace existing jacks.