

AUXILIARY SIGNALS

IDENTIFICATION

1. GENERAL

1.01 This section provides identification, installation, operation, maintenance, and connection information on the KS-16301 type, KS-8000 series and KS-20614 signals with associated apparatus.

1.02 This section is reissued to:

- Revise Table A ordering and operating current information
- Add information on KS-20614, List 2 relay switch
- Remove Part 7—KS-20614 Relay Switch Modification
- Add information on the KS-8229 signal chime
- Revise Fig. 28 and add Fig. 29 for KS-20614, List 1 and List 2 relay switch.

1.03 All KS-16301 codes of signals, relays and backboxes are physically interchangeable.

1.04 These signals may be obtained with or without control relays for use in indoor and outdoor locations. Signals which do not contain a control relay require an externally mounted power relay set. One relay may operate several signals.

1.05 When tip party identification is required, it should be obtained through the ringer associated with each telephone set. Refer to the particular telephone set used for connections.

1.06 Certain signals are equipped with a 0.5- or 0.45-mf capacitor in series with a relay which operates on telephone ringing current. The relay and capacitor constitute a high impedance ringing bridge.

1.07 All signals operate on 115-volt 60-Hz power unless otherwise noted. The operating voltage is stamped on the unit.

1.08 All KS-16301 List 2, List 6, and List 20 series signaling devices are not intended for use with 115 volts ac power and will be provided by the manufacturer with two warning tags, one on the signal unit frame and one on the signal unit power cord near the plug. The tags will specify:

WARNING: DO NOT USE ON 115V 60-Hz.

1.09 The KS-20614 relay switch is intended for use by handicapped persons. ♦The List 1 is equipped with a power cord and switches 110V 60 cycle. The List 2 provides a contact closure for switching a customer low voltage supply not requiring Underwriter Approval.♦

1.10 Relays that operate on telephone ringing current have a 2-position sensitivity adjustment.

2. IDENTIFICATION

2.01 Purpose: To produce loud or distinctive signals from:

- Vibrating bells
- Single-stroke bells
- Chimes
- Horns
- Lamps

2.02 Ordering Guide:

- Refer to Table A for auxiliary signals.
- Refer to Table B for associated apparatus which must be ordered separately.

→TABLE A←
ORDERING GUIDE

SIGNAL	LOCATION	STROKE	OPERATING VOLTAGE	CURRENT (AMPERES)	OUTPUT (db)	RELAY OPERATION ‡	SEE FIG. NO.	SEE TABLE
BELL								
KS-8547,L1	Hazardous Indoor	Vibrating	115V ac	0.10			12	
KS-8547,L2	Hazardous Outdoor	Vibrating	115V ac	0.10			12	
KS-8547,L3*	Hazardous Indoor	Single	115V ac	0.12			12	
KS-8547,L4*	Hazardous Indoor Outdoor	Single	115V ac	0.12			12	
KS-16301,L3	Indoor Outdoor	Vibrating	115V ac	See Table D	101.6		9	B,D
KS-16301,L4	Indoor Outdoor	Single	115V ac		99.6		10	B,D
KS-16301,L20	Indoor Outdoor	Vibrating	18V ac		101.6		11	B,D
KS-20375,L1†	Indoor	Vibrating	18V ac		101.6		13	
CHIME								
KS-8229,L13*	Indoor	Single	115V ac	0.07		48V dc	14	
KS-8229,L14*	Indoor	Single	115V ac	0.07		48V ac	14	
KS-8229,L15*	Indoor	Single	115V ac	0.07		Ringing Current	14	
KS-8229,L23*	Indoor	Single	115V ac	0.07			14	
KS-16301,L1	Outdoor Indoor	Single	115V ac	See Table D			13	B,D
HORN								
KS-16301,L2	Indoor Outdoor		115V dc	See Table D	101.6		16	D
KS-16301,L5	Indoor Outdoor		115V ac		106.6		17	D
KS-16301,L6	Indoor Outdoor		48V ac		101.6		18	D
SWITCH, RELAY								
KS-20614,L1	Indoor					Ringing Current	7	
KS-20614,L2	Indoor					Ringing Current	8 §	

* May be ordered equipped for 115V dc operation.

† Mounts on 2-inch rectangular outlet box, 4-inch square or octagonal outlet box, or single or double gang plaster ring.

‡ ● 48V ac relays will operate on 9V minimum.

● 48V dc relays will operate on 17V minimum.

● Ringing current relays will operate on 53V minimum with wide airgap and 34V minimum with close airgap.

§ Does not include power receptacle or power cord.

→TABLE B←

ORDERING GUIDE

ASSOCIATED APPARATUS	LOCATION	USE WITH				POWER CORD PROVIDED	FOR CONDUIT INST	SEE TABLE	FIG. NO.
		BELL	HORN	CHIME	RELAY				
BACKBOX									
KS-16301,L8*	Indoor	●	●	●	●	Yes	No	C	5
KS-16301,L9*	Indoor	●	●	●	●	No	Yes	C	3
KS-16301,L11*	Outdoor	●	●	●	●	No	Yes	C	19
KS-16301,L19*	Outdoor	●	●	●	●	Yes	No	C	20
OUTLET									
KS-16301,L18†	Outdoor								2
RELAY									
KS-16301,L15	Indoor-Outdoor	●	●	●				E	6
KS-16301,L16	Indoor-Outdoor	●	●	●				E	6
KS-16301,L17	Indoor	●	●	●				E	6

* Mounting hardware not furnished.

† Use with KS-16301,L19 backbox.

3. INSTALLATION

PLANNING

3.01 Select a wall or column location for the signaling device in accordance with the following:

- Not hazardous to maintenance personnel. Avoid stairways, areas of heavy traffic, and moving machinery.
- Best sound distribution.
- Safe from damage. Remote from vehicular traffic, excessive heat, and flammable or corrosive fumes.
- Accessible for maintenance or removal.
- Near power receptacle or conduit, where required.

Customer-Provided Wiring

3.02 Prior to installation, a definite agreement must be made with the customer to provide

any necessary power wiring (ac, dc, receptacle, conduit) in accordance with the following:

- Not controlled by a switch
- Separately fused, if possible
- Within access of power cord.

Line Ringer

Note: Any telephone station having auxiliary signals (except a PBX station) must be equipped with a ringer connected to the line at all times to insure a ringing signal should commercial power fail.

Typical Installation Assembly

3.03 A typical signal (Fig. 1) includes a backbox, a signal premounted to a grilled cover, and a control relay.

3.04 The armature on relays associated with auxiliary signals restores to normal (open contacts) by gravity. Always mount signal on a vertical surface. A control relay, if used, must be in the horizontal position.

Type of Installation

3.05 The type of installation determines the type of backbox (see Table C). Backboards are not necessary.

INSTALLING



Make sure power is disconnected before working on circuit. Under no circumstances should the cord provided for commercial power be passed through

a hole in a wall or be fastened to a wall.

3.06 Weatherproof Power Outlet KS-16301, List 18 (Fig. 2)

- Provided to customer as required
- Furnished with KS-16301, List 19 backbox.

3.07 Backbox (Fig. 1, 3, 5, 19, and 20)

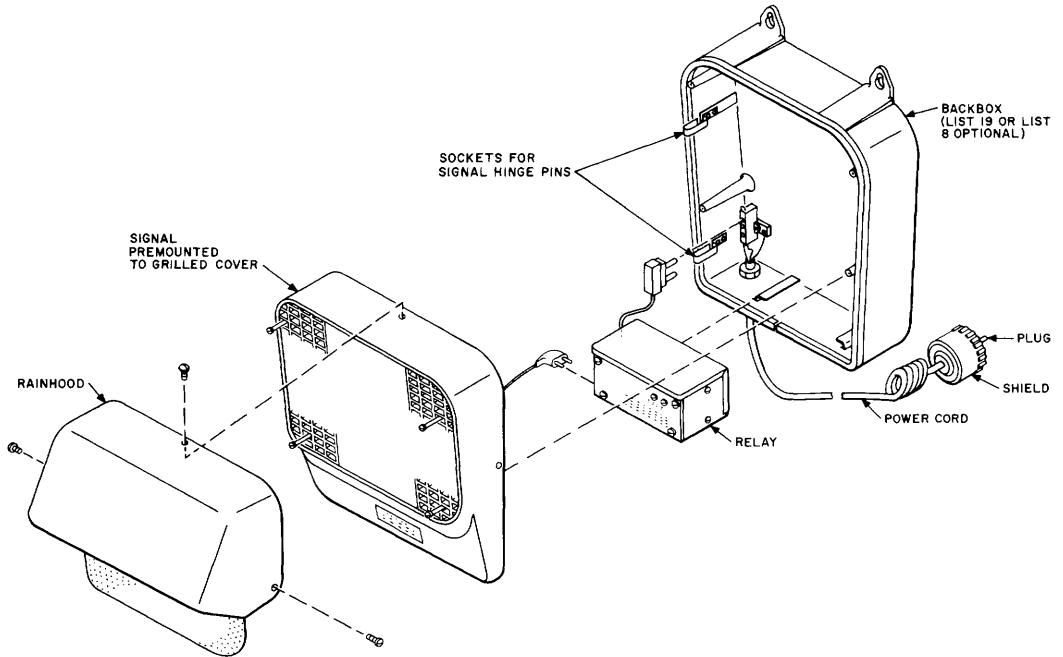

Fig. 1—Exploded View of Assembled Signal Using Relay

TABLE C

BACKBOX	TYPE OF INSTALLATION	
L8	Indoor — Power Cord	For Use With or Without Relay (per job requirements)
L9	Indoor — Conduit	
L11	Outdoor — Conduit	
L19	Outdoor — Power Cord	



Fig. 2—KS-16301, List 18 Outlet

- Mount on a vertical surface.
- Use two slotted holes and one regular hole for attaching backbox to surface.
- Use rustproof fasteners.
- Install backbox, List 9 or 11, so that the customer may have the commercial power connected (Fig. 3).
- Terminate 3-conductor cord as shown in Fig. 4.
- Do not fasten power cord to any surface.
- Do not pass power cord through wall holes or partitions.
- An entrance hole for the telephone wires is located in the bottom of each backbox (Fig. 5).
- Be sure that the gasket on the backbox is in place (Fig. 4).

3.08 Control Relay, KS-16301 (Fig. 6)

- Mount relay in the horizontal position on mounts provided in backbox (Fig. 1).
- Use a full cable pair for each signal circuit when signaling circuits are in the same cable.



Fig. 3—KS-16301, List 9 Backbox

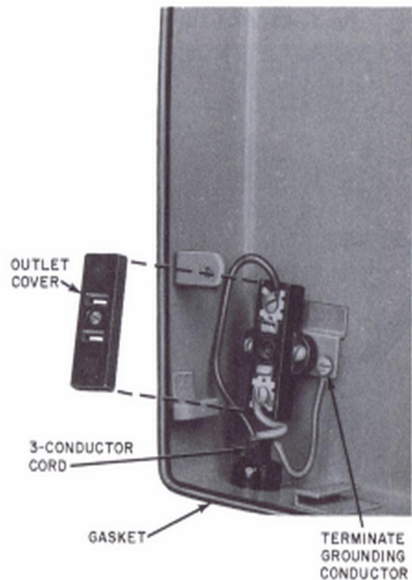

Fig. 4—Power Cord Termination

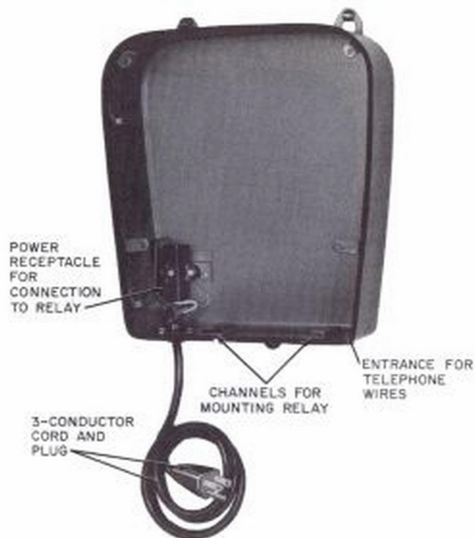

Fig. 5—KS-16301, List 8 Backbox

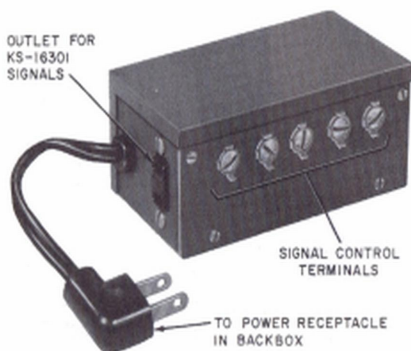

Fig. 6—KS-16301, List 15, List 16, List 17 Relay

- When no talking circuits are involved, low-voltage signal circuits may use half of a cable pair or inside wire.

3.09 Signals, KS-16301 (Fig. 9, 10, 11, 15, 16, 17, and 18)

- Engage the two pins on front cover to form a hinge with the two sockets which emerge from backbox (Fig. 1).

- Fasten the signal to the backbox with four machine screws which are furnished (Fig. 1).

3.10 Rainhood, KS-16301, Lists 11 and 19 (Fig. 19)

- For protection against the weather and insects
- Attach with furnished screws to the signal unit (Fig. 1).

3.11 KS-20614, List 1 Relay Switch (Fig. 7 and 28)

- Mount relay to a vertical surface with contacts at the bottom and within 12 inches of local power receptacle.

- Connect the tip and ring from the telephone set connecting block to terminal board in relay housing. Connect ring to "HI" for long loop or "LO" for dial area.

- Set single-pole double-throw switch on nearby table or stand.

- Connect visual indicator to receptacle in relay housing.

3.12 KS-20614, List 2 Relay Switch (Fig. 8 and 29)

- Mount relay to a vertical surface with contacts at the bottom.

- Connect the tip and ring from the telephone set connecting block to terminal board in relay housing. Connect ring to "HI" for long loop or "LO" for dial area.

- Terminate 2-conductor cord on a 42A connecting block, or equivalent, as a junction point for the customer's low voltage circuit.

- Set single-pole double-throw switch on nearby table or stand.

3.13 Signals, KS-8000 Series (Fig. 12 and 14)

- (a) Bell and chime:
- The signals are for indoor locations.
 - Signal is already attached to a backboard.
- (b) Chime only:
- Has slotted mounting holes for easy removal from backboard.
 - Has 2-conductor cord for terminating on a 42-type connecting block or equivalent.

4. OPERATION

4.01 Noncontinuous Signals (Fig. 26): The 687B subscriber set has a cold cathode tube and relay in place of the ringer. When the relay is operated by rectified ringing voltage, the relay contacts may be used to control a signal energized from a local low voltage source.

4.02 Continuous Signals (Fig. 27): The circuit operates as follows:

- (a) Ringing current applied to line operates R relay through its secondary winding, through top contacts 1 and 2 of SR relay to ground.
- (b) R relay locks operated by battery through its primary winding, through its own top contacts 1 and 2, through bottom contacts 3 and 2 of SR relay, through bottom contacts 1 and 2 of TO relay (Z wiring) to ground, or to switch to ground (Y wiring).
- (c) R relay operated completes circuit through its own top contacts 3 and 4 to operate auxiliary relay or signal.
- (d) Bottom contacts 1 and 2 of R relay may be used to operate a line lamp indicator.
- (e) When call is answered, B relay operates by central office or PBX battery through station.

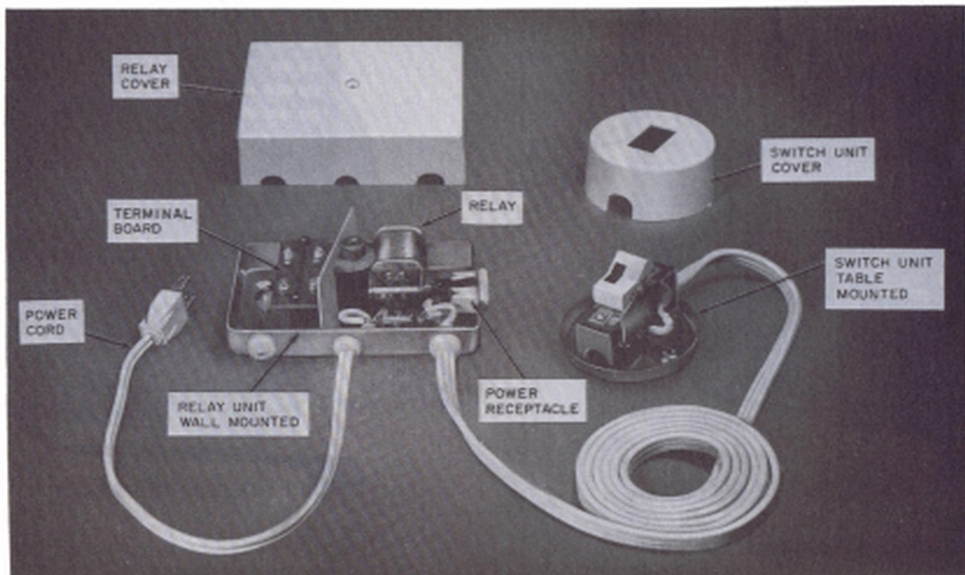

Fig. 7—KS-20614, List 1 Relay Switch

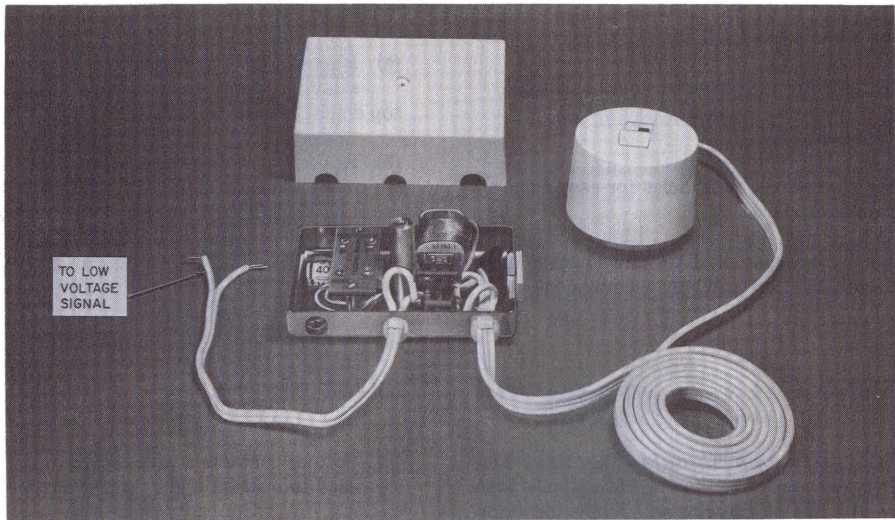

Fig. 8—KS-20614, List 2 Relay Switch

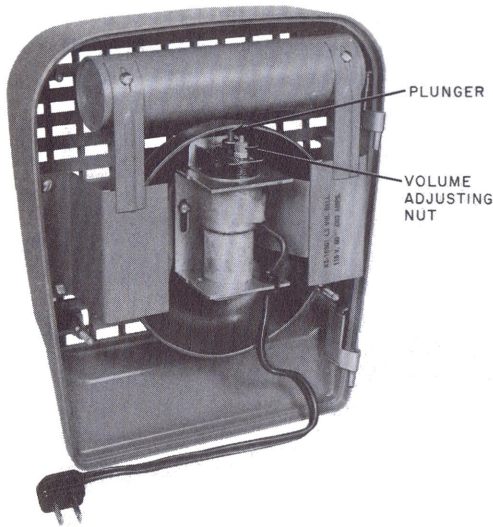

Fig. 9—KS-16301, List 3 Bell

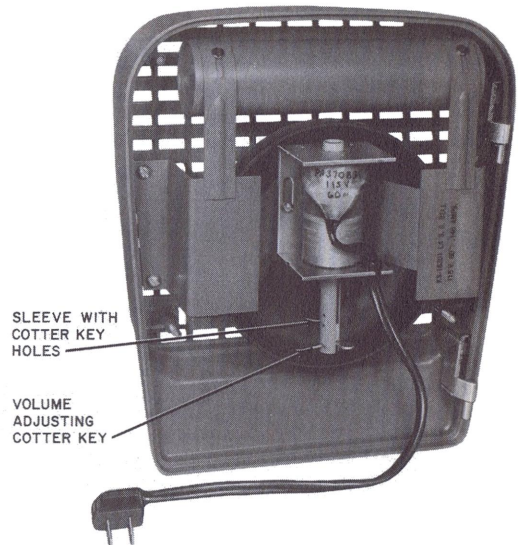

Fig. 10—KS-16301, List 4 Bell

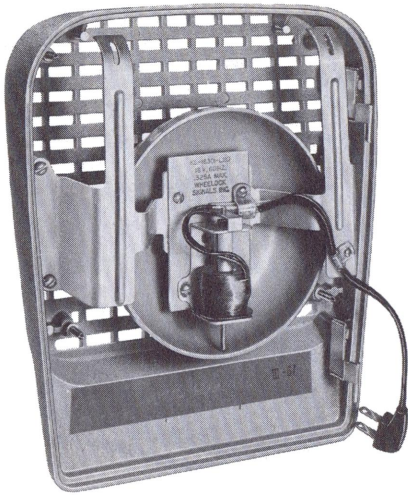

Fig. 11—KS-16301, List 20 Bell



Fig. 13—KS-20375, List 1 Bell

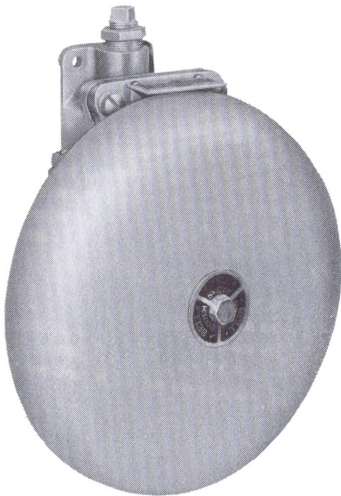

Fig. 12—KS-8547, List 1 Bell

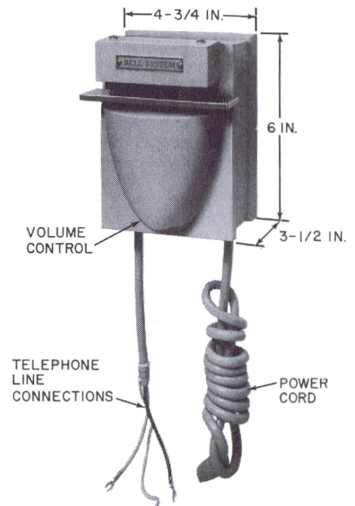

Fig. 14—KS-8229 Chime



Fig. 15—KS-16301, List 1 Chime



Fig. 17—KS-16301, List 5 Horn

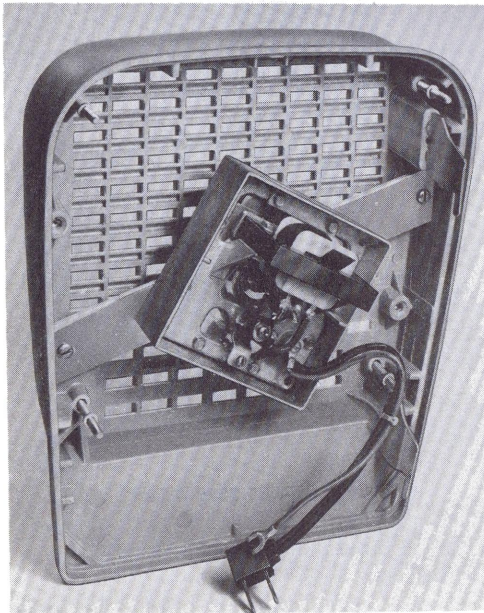

Fig. 16—KS-16301, List 2 Horn

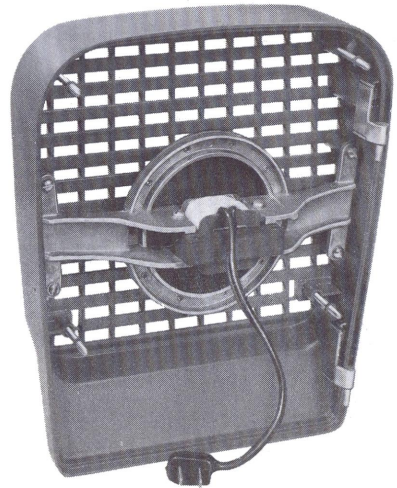

Fig. 18—KS-16301, List 6 Horn

(f) SR relay operates by battery through its winding through contacts of B relay (operated),



Fig. 19—KS-16301, List 11 Backbox

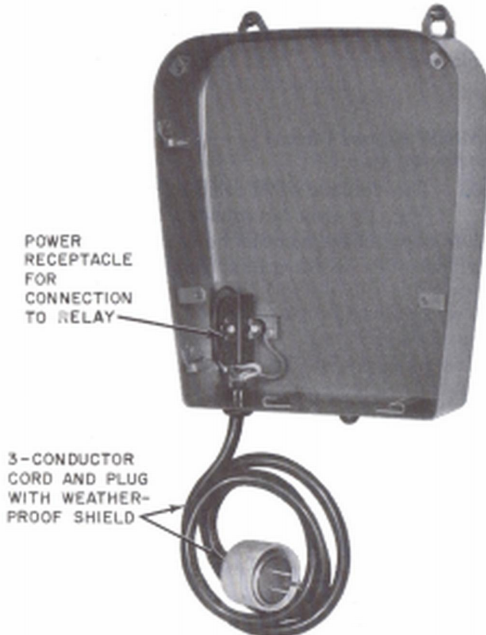

Fig. 20—KS-16301, List 19 Backbox

and through bottom contacts 1 and 2 of TO relay to ground (Z wiring).

(g) Operation of SR relay opens locking circuit of R relay which releases.

(h) Circuits to auxiliary signal and line lamps open when R relay releases.

(i) Unanswered calls are handled by a timeout feature. When R relay operates, ground is connected through bottom contacts 3 and 4, through 112-ohm heater winding of TO relay (Z wiring), and through top contacts 3 and 2 of TO relay to battery. After approximately 30 seconds, thermally operated bottom contacts 1 and 2 of TO relay will open. This opens locking circuit of R relay, and circuit restores to normal.

(j) If call is answered, SR relay operates as previously described. Circuit is completed from battery through TO relay, through bottom contacts 1 and 2 of SR relay (operated), and through bottom contacts 1 and 2 of TO relay to ground. This opens heater winding circuit of TO relay.

4.03 KS-20614, List 1 Relay Switch (Fig. 28):

The relay is operated by station ringing voltage to control a 2-conductor 115V receptacle. The switch reverses function of the relay contacts so that the 115V receptacle can be either normally on or off with reversal occurring during the ringing interval. Provides for control of any alerting device (visual, tactile or audible) that operates on 115V, 60 Hz and draws 5 amperes or less noninductive load.

4.04 KS-20614, List 2 Relay Switch (Fig. 29):

Operation of the List 2 is similar except the contacts are used to control a customer-provided low voltage circuit (maximum 30 volts and 3.2 amperes) wired to the 12-inch 2-conductor cord provided.

5. MAINTENANCE

Warning: Before performing any work on equipment connected to commercial power de-energize the power supply circuit. The customer shall arrange for power disconnection and reconnection on power circuits other than plug and outlet.

Signals, KS-16301

5.01 The KS-16301, List 3 (vibrating bell) has a volume adjustment. On the Wheelock Signal Company type, the adjustment is a hexagonal nut on the rear of the signal (Fig. 9). The Sperti-Faraday Company type adjustment is on the back of the

bell resonator. The direction of adjustment is stamped near the adjusting nut or screw. Table D shows operating currents.

5.02 The KS-16301, List 4 (single-stroke bell) uses a cotter key volume adjustment. The signal is shipped with the key inserted through the lowest of the three holes in the sleeve that contains the plunger for maximum volume. To decrease volume, move cotter key to intermediate or top hole in the sleeve (Fig. 10).

5.03 Replace defective signals with complete list number.

Relays, KS-16301, KS-20614

5.04 The Lists 15, 16, and 17 relays should meet the following requirements: (Table E)

- The armature should not chatter when the relay is operated with the specified voltage.
- The armature should not bind or stick; gauge by feel.
- The armature airgap is adjusted on Wheelock Signal Company relays by moving a lever on the bottom of the relay.

- In Sperti-Faraday Company relay, the armature airgap is adjusted by rotating the armature airgap adjusting screw 1/2 turn to the desired setting.

- Minimum contact pressure is 6 grams, measured with relay operated either electrically or manually; use 70H gauge.

- The contacts should make almost simultaneously; gauge by eye.

- The armature and pole piece should be free of dirt or metal filings. Clean with 1/2-inch relay cleaning strips or equivalent.

5.05 KS-16301, List 15 and KS-20614 relays used as a ringing bridge should not chatter during dial pulsing to the extent that contacts make. Check position of HI or LO sensitivity adjustment, ie, HI for long loop or LO for dial area. If relay meets all requirements but chatters on dial pulsing, replace in accordance with local instructions.

KS-8229 Signal Chime

5.06 The volume of the KS-8229 signal chime (Fig. 14) may be adjusted by a screw. No other adjustment should be made. Should the plunger stick in its guide, remove plunger and

TABLE D

SIGNALS, KS-16301

OPERATING CURRENT REQUIREMENTS

SIGNAL	LIST NO.	OPERATING CURRENT IN AMPERES		
		MFD BY SPERTI-FARADAY COMPANY	MFD BY WHEELOCK SIGNAL COMPANY	MFD BY EDWARDS COMPANY INC.
Bell	3	0.084	0.113	0.075
	4	0.89	1.22	—
	20	—	0.20	—
Chime	1	1.32	1.22	—
Horn	2	0.125	0.36	0.075
	5	0.68	0.65	0.170
	6	0.55	1.70	0.490

TABLE E
RELAYS, KS-16301
OPERATING REQUIREMENTS

RELAY	OPERATING VOLTAGE	OPERATING CURRENT AT MAX VOLTAGE	DC RESISTANCE OF RELAY COIL	IMPEDANCE OF RELAY COIL	RELAY CONTACT-CARRYING CAPACITY
LIST NO.		AMPERES	OHMS	OHMS	AMPERES
15	18 to 48 volts dc	0.011	4500	—	5
	30 to 48 volts 60 Hz ac	0.025	1000	1920	
	39 to 90 volts 20 Hz ac (ringing voltage)	0.012	4500	7550*	
16	9 to 48 volts 60 Hz ac	0.404	26.3	118	
17	12 to 78 volts dc	0.069	1130	—	

* Includes 0.45-mf series capacitor.

clean with mineral spirits. If this does not correct operation, replace signal device.

5.07 Some auxiliary signals can cause malfunctions in frequency counters at computer installations due to arcing of the ac contacts of the signal, inducing noise in the ac line and radiating in the line cord of the computer. The problem can be alleviated by installing a 0.02 mf capacitor across the ac contacts of the auxiliary signal.

6. CONNECTIONS

6.01 Connections for KS-16301 signals and relays are shown in Fig. 21.

6.02 Several signals may be connected as shown in Fig. 22. This has the advantage of only one ringing bridge on the telephone line for several auxiliary signals. The total number of auxiliary signals connected to a power relay set should not exceed the current carrying capacity of the relay contacts. Special commercial power wiring is not needed between relay set and signals.

6.03 The KS-8233, List 2 transformer relay set has been used to connect several signals to

one telephone line, as shown in Fig. 23. This may be encountered in some existing installations.

6.04 Connections for signals which do not have a self-contained power relay are shown in Fig. 24. These signals require commercial power wiring between relay set and signal.

6.05 Auxiliary signals may be installed on 4-party full selective or 8-party semiselective lines by connecting a 531C or 687B subscriber set as shown in Fig. 25.

6.06 Connections for noncontinuous low voltage signals such as bells, buzzers, and lamp indicators are shown in Fig. 26.

6.07 Continuous operating signals, either low voltage or power operated, should be connected as shown in Fig. 27. Low voltage signals connect directly to the 15D key telephone unit.

6.08 KS-20614 relay switch connections are shown in Fig. 28 and 29.

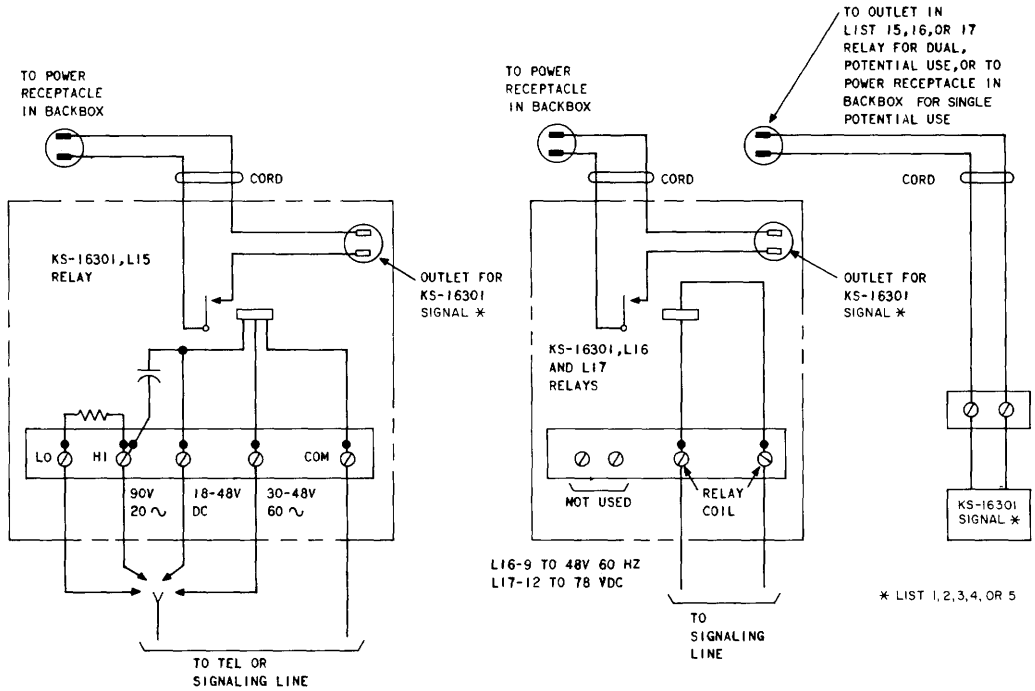

Fig. 21—KS-16301 Signal and Relay

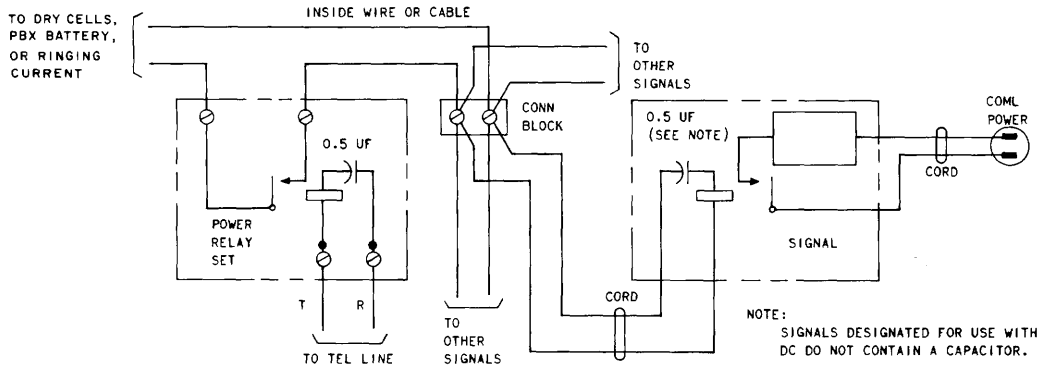

Fig. 22—Multiple Signal

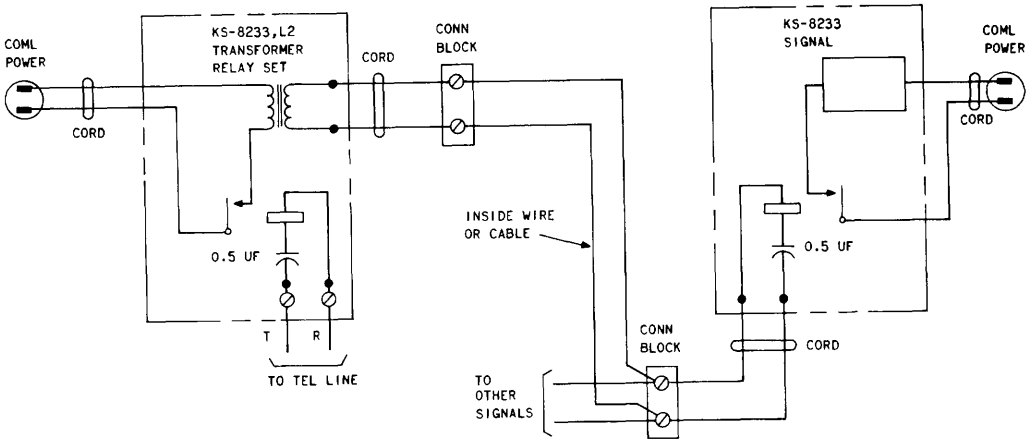
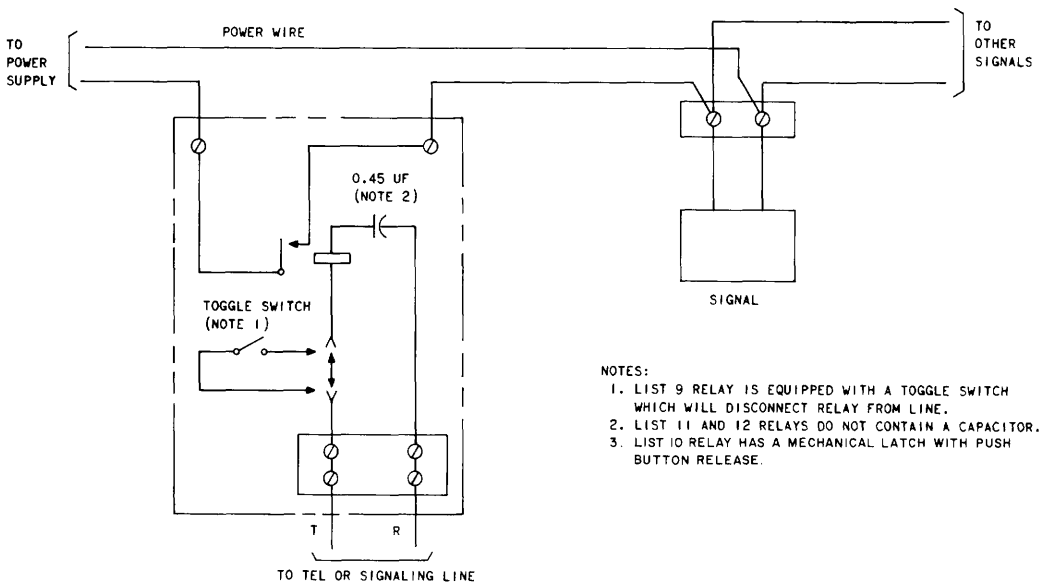

Fig. 23—KS-8233, List 2 Transformer Relay Set



- NOTES:
1. LIST 9 RELAY IS EQUIPPED WITH A TOGGLE SWITCH WHICH WILL DISCONNECT RELAY FROM LINE.
 2. LIST 11 AND 12 RELAYS DO NOT CONTAIN A CAPACITOR.
 3. LIST 10 RELAY HAS A MECHANICAL LATCH WITH PUSH BUTTON RELEASE.

Fig. 24—KS-16626 Power Relay Set

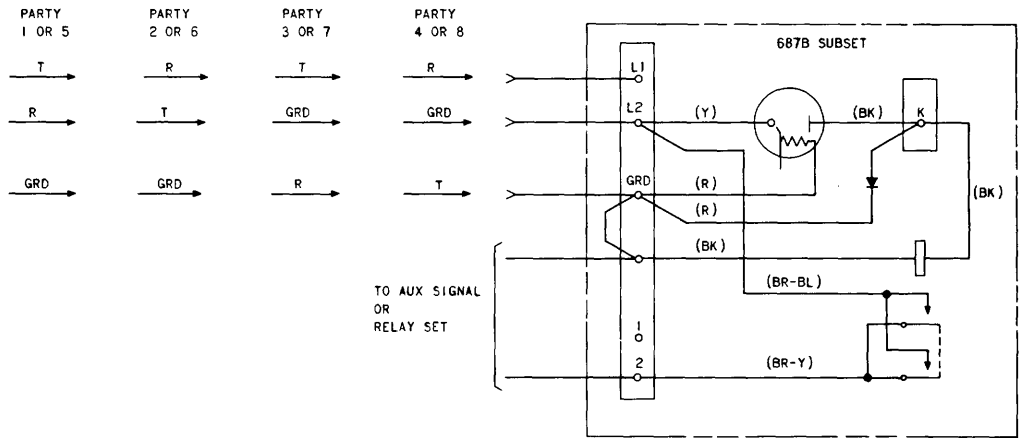

Fig. 25—Auxiliary Signals on Party Line

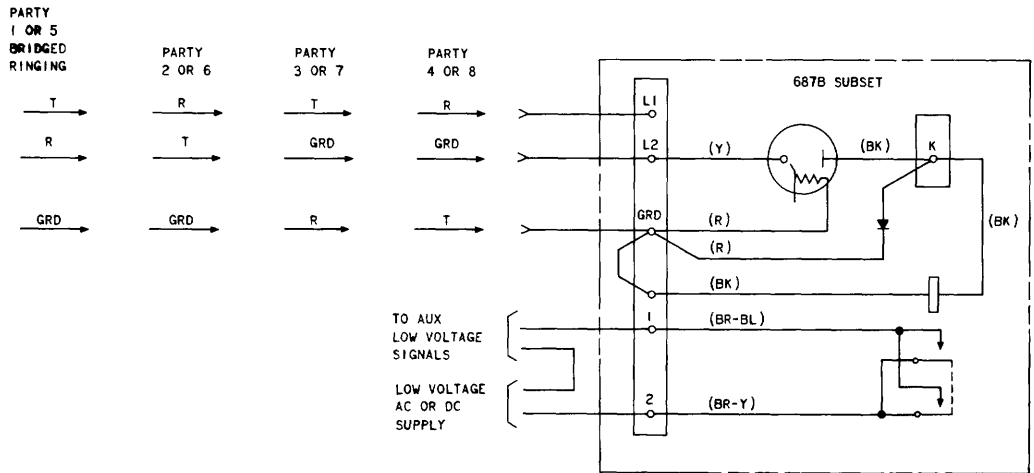

Fig. 26—Noncontinuous Low Voltage Auxiliary Signal

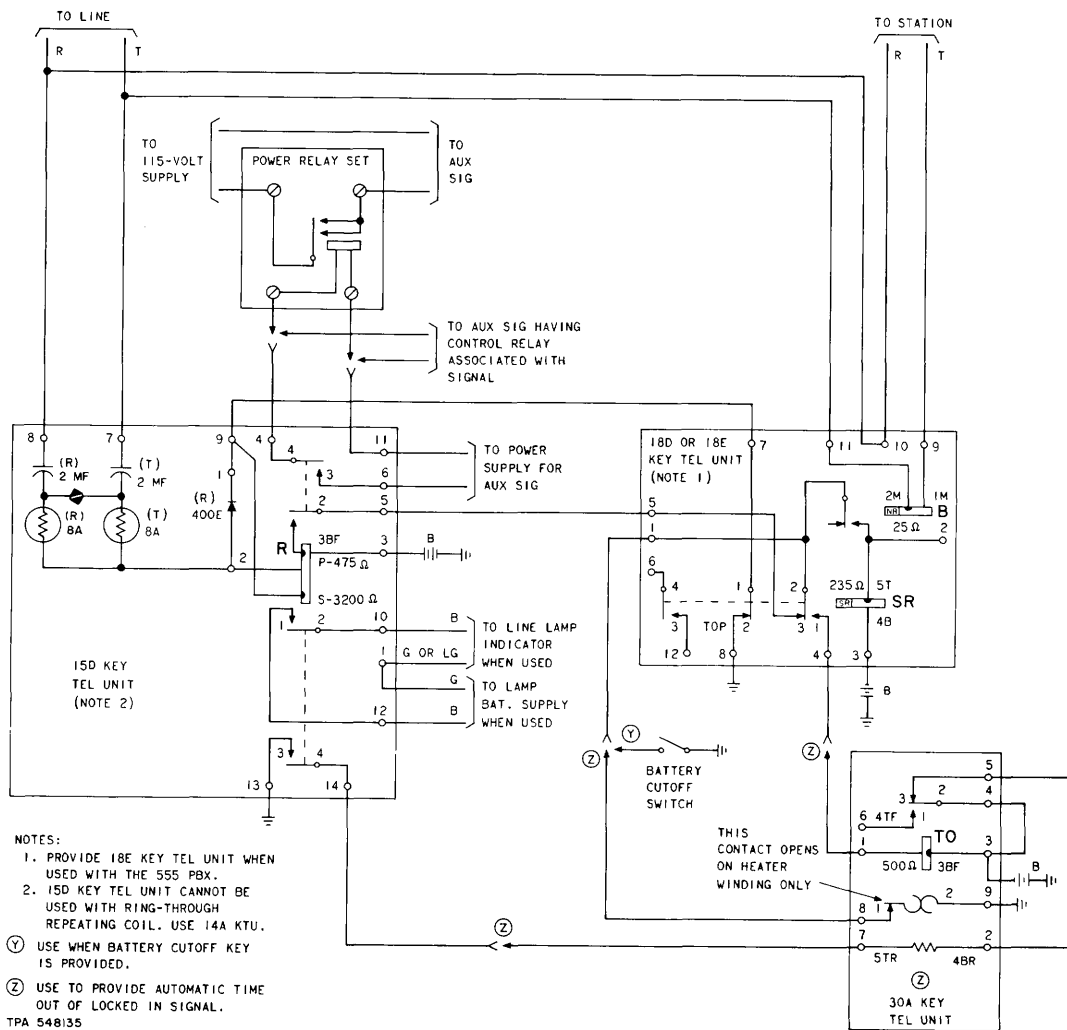

Fig. 27—Connections and Circuit Operation for Continuous Auxiliary Signals

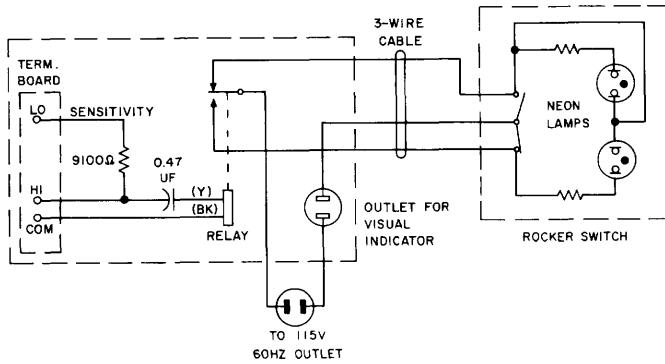

Fig. 28—KS-20614, List 1 Relay Switch—Schematic

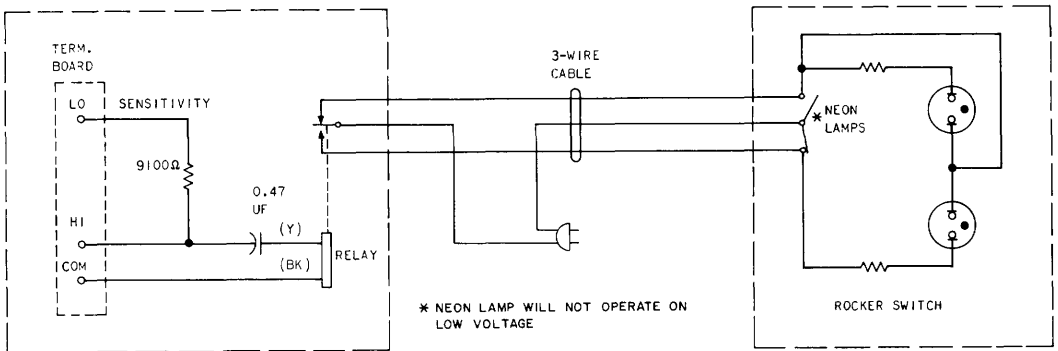

Fig. 29—KS-20614, List 2 Relay Switch—Schematic