

**REGISTRATION INTERFACE**  
**SERIES SINGLE LINE**  
**TIP AND RING ARRANGEMENTS**  
**RJ31X, RJ32X, RJ33X, RJ34X, AND RJ35X**

**1. GENERAL**

**1.01** This section provides information on the standard arrangements to be provided under the Federal Communications Commission's (FCC) registration program for registered ancillary, data, and protective circuitry of the type associated with ancillary and data customer-provided equipment (CPE).

*Note:* Customer-provided data equipment connected to the network via the jacks in this section must have a fixed signal power level under -9 dBm. See Section 590-101-103 for connection of other data devices.

**1.02** Whenever this section is reissued, the reason(s) for reissue will be listed in this paragraph.

**1.03** The arrangements covered in this section require the installation of a 635A connecting block. This connecting block is designed to place the CPE in series with the telephone line and the telephone company equipment when the plug from the CPE is inserted in the modular jack. In this mode, loop continuity must be maintained through the registered equipment. When the CPE plug is removed, the circuit is restored between the line and the telephone company equipment by the shorting bars.

**1.04** In all the arrangements, tip and ring of a single line are supplied through the interface. Where the arrangement is used with a key telephone system (KTS), the A and A1 leads are also furnished on a bridged basis.

**1.05** All unused leads and terminals are reserved for telephone company use. Disposition of spare leads should be per local instructions. All

contact positions of the modular jack used in the 635A connecting block are equipped with leads. In early production, the leads associated with contacts 2 and 7 were not terminated but were insulated and stored.

*Note:* Circuit incompatibility may occur involving spare leads if a change in service is installed, ie, a line with "A" lead control installed originally would not be compatible with a subsequent installation involving a data set. Whenever service is altered at an installation involving registration Uniform Service Order Codes (USOCs), check that all appearances are properly wired.

**1.06** Unless otherwise specifically required by a particular wiring arrangement, access to the required leads can be at any access point. USOC RJ35X must be accessed in the telephone set in order to provide the series tip and ring connection of all lines appearing in the set. Fig. 5 provides modification of the more common sets. For the other arrangements, if installed in a large KTS with color-keyed backboards, the auxiliary (yellow) field should be used; otherwise, access at satellite closets, distribution boxes, connecting blocks, etc.

**1.07** When necessary to access leads in COM KEY\* installations, wire as follows:

(a) COM KEY 416—Tip and ring ahead of the line circuit can be obtained only at the 91A connecting block for the primary station. A and A1 will require use of a KS-19252 adapter in the cabling loop. A short length of connector cable must be plugged into the adapter and the raw end terminated on a 66-type connecting block. The required leads are then accessed on the connecting block. Where T, R, A, and A1

\*Trademark

**NOTICE**

Not for use or disclosure outside the  
Bell System except under written agreement

are required behind the line circuit, the KS-19252 adapter and short connector cable are again used, but all leads are accessed on the 66-type connecting block. Refer to Section 518-450-105 for information on COM KEY 416.

(b) COM KEY 718—Tip and ring ahead of the line circuit can be obtained at the incoming CO/PBX line terminations on block 3 using 183B2 adapters. If T, R, A, or A1 are required behind the line circuit, they can be accessed per line at any of the line appearances of the station terminations on blocks 3, 4, or 5. Again use 183B2 adapters. For information on COM KEY 718, refer to Section 518-450-100.

(c) COM KEY 1434—Tip and ring ahead of the line circuit can be accessed at the incoming line terminations on block 7 using 183B2 adapters. T and R behind the line circuit and A and A1 for a particular line can be accessed at any of the line appearances of the station terminations on blocks 6 through 15 using 183B2 adapters. For information on COM KEY 1434, refer to Section 518-450-102.

(d) COM KEY 2152—Because of insufficient clearance between the connecting blocks and the closed gate, 183B2 adapters cannot be used on the connecting units of COM KEY 2152. To access T and R ahead of the line circuit, route the incoming CO/PBX line to an external 66-type connecting block, then to block 3 of the 100A1 or 101A1 connecting unit. The 66-type connecting block is then used to provide a multiple of the line. To access T and R behind the line circuit, use an idle station code termination which must be sacrificed for system use. If no idle station terminations are available, use any station code by running a jumper cable to external 66-type connecting blocks and transferring the station cable to these blocks. The blocks are then used to provide the line appearance multiple. For information on COM KEY 2152, refer to Section 518-450-110.

## 2. IDENTIFICATION

**2.01 USOC RJ31X:** This arrangement is wired so that when the CPE is plugged into the 635A connecting block, the CPE is placed in series with the tip and ring of the line (Fig. 1). When the CPE plug is removed, tip and ring are cut through to the station equipment. *The 635A*

*connecting block must be wired in the circuit, ahead of ALL station equipment, to prevent false operation of the registered device and to cut off ALL station equipment from the line.*

**2.02 USOC RJ32X:** This arrangement (Fig. 2) also provides a series tip and ring connection through the 635A connecting block but is used where the CPE is connected in series with a single station, such as an automatic dialer.

**2.03 USOC RJ33X:** Provides a series connection of the tip and ring of a KTS line ahead of the line circuit because the registered equipment requires CO/PBX ringing and a bridged connection of A and A1 from behind the line circuit (Fig. 3). Tip and ring are the only leads opened when the CPE plug is inserted in the 635A connecting block. Typical usage would be for customer-provided automatic dialers or call restrictors. Access to the required leads can be anywhere leads are available, but tip and ring must be ahead of the line circuit.

**2.04 USOC RJ34X:** This arrangement provides a series tip and ring connection and a bridged A and A1 to the CPE. All leads are connected behind the line circuit (Fig. 4). Typical usage is for automatic dialers and call restrictors.

**2.05 USOC RJ35X:** Provides a series tip and ring connection to whatever line has been selected in a key telephone set plus a bridged A and A1. The arrangement requires that the set wiring be modified as shown in Fig. 5 to put the CPE in series with the T and R multiple from the key(s) and the T and R going to the speech network. Connections between the 635A connecting block and the telephone set terminals can be made using a D6AA cord.

## 3. MAINTENANCE

**3.01** Maintenance of the wiring arrangements covered in this section is limited to:

- Verification of the telephone company wiring and equipment
- Assurance that the required leads are supplied in the interface used for CPE connection.

No attempt should be made to test, modify, or repair customer-owned and maintained equipment.

- Section 660-101-318—Tariff and Registration Violation Notice Procedures.

**3.02** When in the judgment of repair personnel the trouble is located in or caused by the CPE, the Repair Service Bureau should be notified so that proper Maintenance of Service Charge Billing can be initiated as required and as outlined in the following:

- Section 660-101-312—Maintenance of Service Charge on Services With Customer-Provided Equipment (CPE)

NOTES:

1. SHORTING BARS OPEN CIRCUITS BETWEEN 1-4 AND 5-8 WHEN CPE PLUG IS INSERTED IN JACK.
2. IN EARLY PRODUCTION LEADS 2 AND 7 WERE NOT TERMINATED.

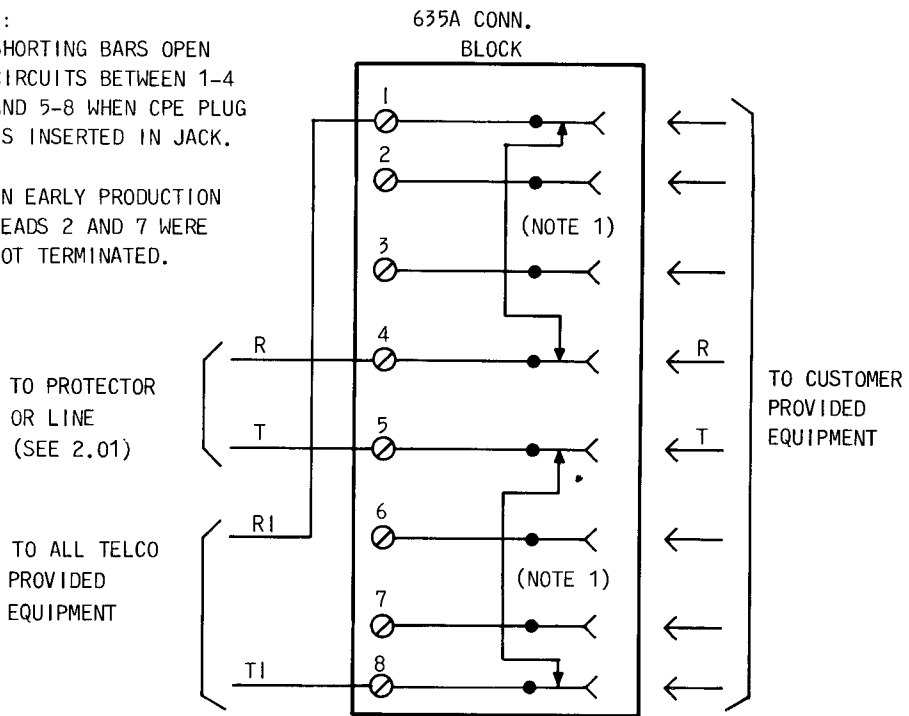

Fig. 1—Connections for USOC RJ31X

NOTES:

1. SHORTING BARS OPEN CIRCUITS BETWEEN 1-4 AND 5-8 WHEN CPE PLUG IS INSERTED IN JACK.
2. IN EARLY PRODUCTION LEADS 2 AND 7 WERE NOT TERMINATED.

INSIDE WIRE FROM PROTECTOR (SEE 2.02)

TO TELCO PROVIDED EQUIPMENT ASSOCIATED WITH CPE

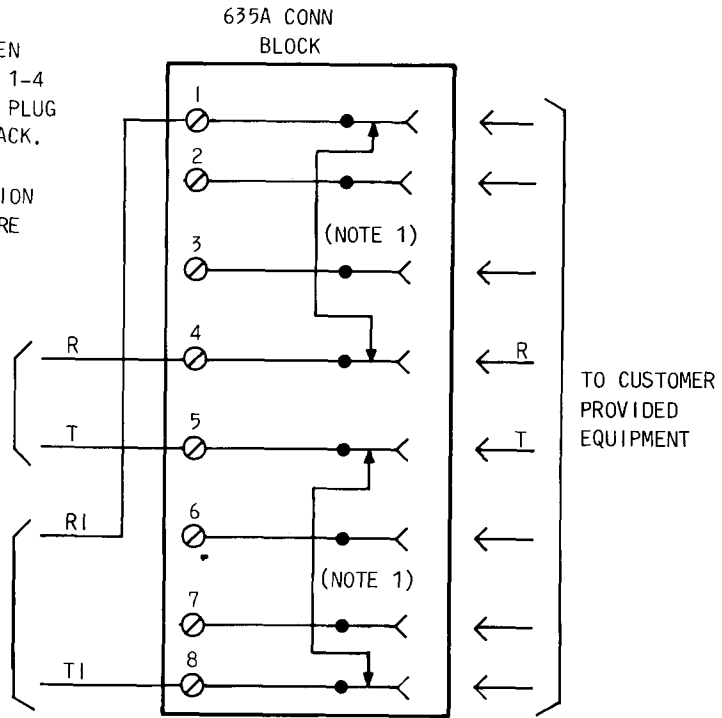

Fig. 2—Connections for USOC RJ32X

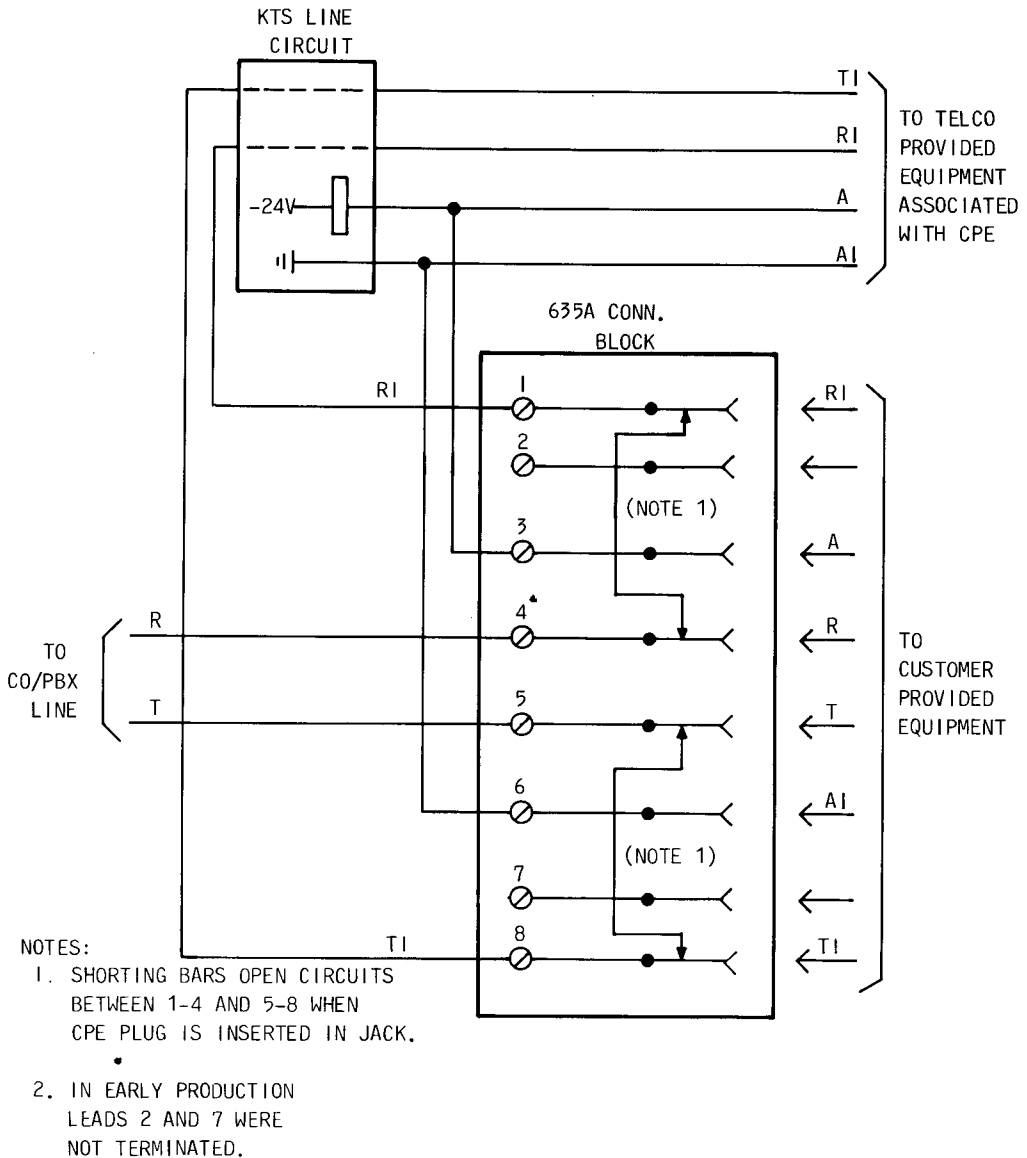

Fig. 3—Connections for USOC RJ33X

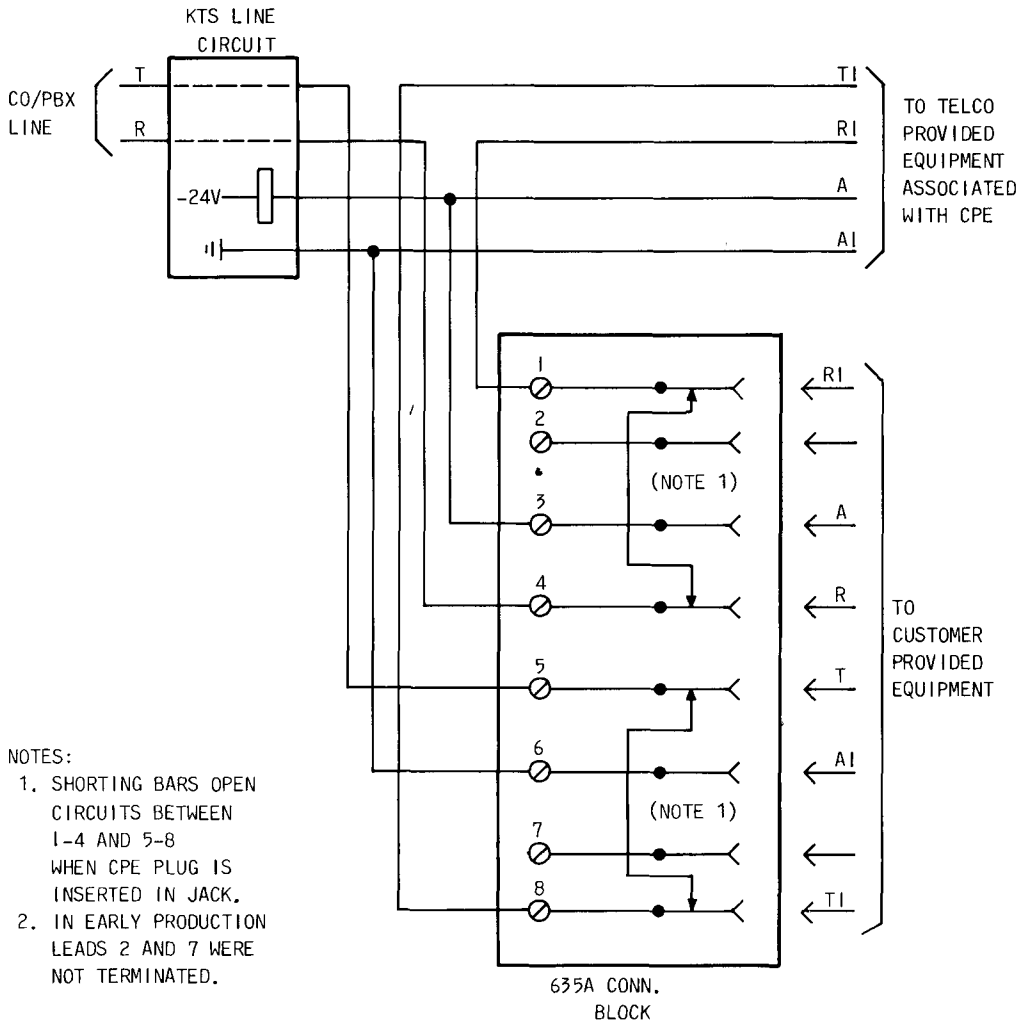
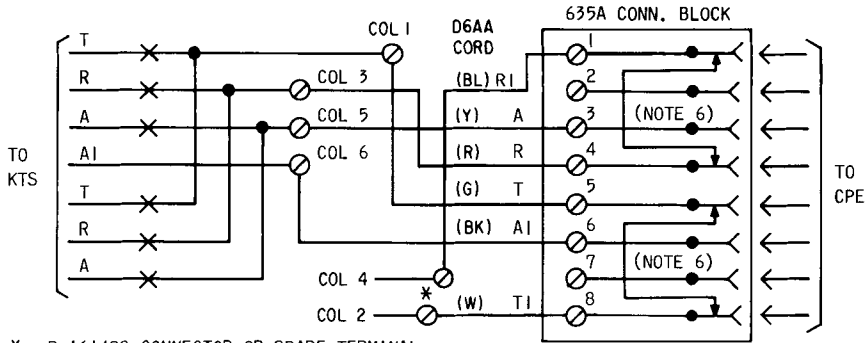

Fig. 4—Connections for USOC RJ34X



\* D-161488 CONNECTOR OR SPARE TERMINAL

NOTE: IN EARLY PRODUCTION LEADS 2 AND 7 WERE NOT TERMINATED.

TELEPHONE SET CODE	COLUMN 1	COLUMN 2	COLUMN 3	COLUMN 4	COLUMN 5	COLUMN 6
	T	TI	R	RI	A	AI
565GK	F	BL (DIAL)	N	G	M	IB
565HK/LK			9	(L SW)		
2565GK	L2	G (DIAL)	N	G		
2565HK/LK			9	(L SW)		
630D/631D			2	G	5	1
630DA/631DA	F	BL (DIAL)	13	(L SW)	7	8
636C/637D			2	BL-W	5	1
636CA/637CA			9	(FLASH)	7	8
2630D/2631D	4		2	G	5	1
2630DA/2631DA	12	G (DIAL)	13	(L SW)	7	8
2636C/2637D	4		2	BL-W	5	1
2636CA/2637DA	12		9	(FLASH)	7	8
851-TYPE	F	BL (DIAL)	13	G	9	4
2851-TYPE	20	G (DIAL)				
830/831-TYPE	F	BL (DIAL)	6	G (L SW)	7	10
2830/2831-TYPE	8	G (DIAL)				
832/833-TYPE	F	BL (DIAL)				
2832/2833-TYPE		G (DIAL)				
634D/635D	F	BL (DIAL)	12	G(L SW)	5	1
634DA/635DA	F	BL (DIAL)	13	G(L SW)	56 *	10
2634D/2635D	4	G (DIAL)	2	G(L SW)	5	1
2634DA/2635DA	L2	G (DIAL)	13	G(L SW)	56	10

MODIFY SETS AS FOLLOWS:

1. DISCONNECT COLUMN 2 LEAD FROM COLUMN 1 TERMINAL. CONNECT TO TI LEAD FROM JACK USING D-161488 CONN. OR SPARE TERMINAL.
2. CONNECT T LEAD FROM JACK TO COLUMN 1 TERMINAL.
3. DISCONNECT COLUMN 4. LEAD FROM COLUMN 3 TERMINAL. CONNECT TO RI LEAD FROM JACK USING D-161488 CONN. OR SPARE TERMINAL.
4. CONNECT R LEAD FROM JACK TO COLUMN 3 TERMINAL.
5. CONNECT A AND AI LEADS TO TERMINALS IN COLUMNS 5 AND 6 RESPECTIVELY.
6. SHORTING BARS OPEN CIRCUITS BETWEEN 1-4 AND 5-8 WHEN CPE PLUG IS INSERTED IN JACK.

Fig. 5—Connections for USOC RJ35X