

557A PBX

IDENTIFICATION, INSTALLATION, AND CONNECTIONS

TELEPHONE SECRETARIAL SERVICE

1. GENERAL

1.01 This section provides information for the identification, installation, and connections for the 557A PBX when used as a single or multiposition manual switchboard, providing combined PBX service and secretarial answering service, at bureaus furnishing answering service to telephone subscribers.

1.02 This section is reissued to:

- (a) Add information on the treatment of central office lines under the Federal Communications Commission (FCC) Registration Program
- (b) Show the electromechanical secretarial line equipment (J59023G-1) manufacture discontinued (MD)
- (c) Rearrange title
- (d) Add information on the new solid-state secretarial line equipment YW1 circuit pack (J59023G-2)
- (e) Add information on the +5 volt power supply required for the YW1 solid-state secretarial line unit
- (f) Correct list numbers on the equipment summary chart in Table B
- (g) Show the J59013H tie trunk, the J59013J automatic tie trunk, and the J59013L manual conference circuit (MD) for use with the 557A PBX
- (h) Show the rotary and TOUCH-TONE® calling card dialers (MD) for use in the 557A PBX.

Revision arrows are used to emphasize the more significant changes. The Equipment Test List (ETL) is not affected.

1.03 ♦Incoming central office lines to be installed in compliance with the FCC Registration Program must be routed through a standard network interface. Information on approved interfaces is contained in Sections 463-400-100 through 463-400-150.

1.04 After January 1, 1980, the YW1 circuit pack solid-state secretarial line unit must be used on new installations. Previously connected or Class C electromechanical secretarial line units may be used for additions and maintenance at grandfathered installations for the life of the equipment, provided they are not modified.

1.05 Refer to Section 473-602-210 for the test and inspections at the time of installation. Section 981-530-100 is the general description of the 557A PBX and Section 809-720-150 should be referred to for ordering information.♦

2. IDENTIFICATION

GENERAL

2.01 The 557A PBX (Fig. 1) is a single or multiposition manual switchboard designed to serve as a combined PBX and secretarial answering service switchboard (direct and concentrator-identifier) at bureaus furnishing answering service to telephone subscribers. Secretarial lines have single jack and lamp appearances in the face of the switchboard. Station lines and trunks may have either single or multiple jack and lamp appearance in the face of the switchboard. A rotary or TOUCH-TONE calling dial, ordered separately and installed locally, is required for completing calls to central offices and other dial system PBXs.

2.02 ♦The following equipment that was previously available as adjuncts to the 557A PBX has been designated (MD) for installation in conjunction with the 557A PBX:

- Manual conference circuit
- Dial tie trunk

NOTICE

Not for use or disclosure outside the
Bell System except under written agreement

SECTION 473-601-201

- Automatic tie trunk
- Rotary or TOUCH-TONE calling card dialers.◀

2.03 The switchboard (Fig. 2) is constructed of a steel inner framework on which the equipment is carried. A wooden casing to enclose this framework must be ordered separately and installed locally. The enclosed switchboard is 2 feet 5-3/8 inches wide, 4 feet 11-3/16 inches high, and 2 feet 5-7/16 inches deep. The top of the writing shelf is 30 inches above the floor (Fig. 1).

2.04 Mounting space for a maximum of three 2- by 23-inch mounting plates is provided in the rear bottom section of the switchboard for central office trunks, tie trunks, a conference circuit, and station line relays. Mounting plates for additional units must be mounted outside of the switchboard section when the desired combination of trunks and miscellaneous circuits exceeds the available mounting space.

CAPACITY

2.05 The capacity of the single position 557A PBX is shown in Table A.

SECRETARIAL LINE EQUIPMENT — J59023G-1 (ELECTRO-MECHANICAL [MD])

2.06 The electromechanical secretarial line equipment is furnished in self-contained units of 20 line circuits per unit. ◀This electromechanical line equipment is rated (MD) and is replaced by the solid-state secretarial line (YW1) circuit pack.◀ A maximum of five secretarial line units can be mounted in one switchboard position. The ◀electromechanical◀ secretarial line unit (Fig. 3) is ordered separately and installed locally. Unequipped ◀electromechanical◀ secretarial line unit spaces in the face of the switchboard shall be covered with line unit blank P-34A583 ◀(comcode 813415833),◀ which is also ordered separately and installed locally. Each ◀electromechanical◀ secretarial line unit is 3 inches high and extends the full width of the switchboard jack panel opening. The ◀electromechanical◀ secretarial line units are installed and removed from the rear of the switchboard and connected to the outgoing terminal strip through a plug mounted on each

side of the unit and sockets wired to the local switchboard cable.

◀SECRETARIAL LINE EQUIPMENT — J59034G-2 (SOLID-STATE YW1 CIRCUIT PACK)

2.07 The solid-state secretarial line equipment (Fig. 4) is furnished in self-contained units of 20 line circuits per unit. These units are equipped with the solid-state YW1 circuit pack (Fig. 5) line units plugged into 912A connectors mounted on the unit. A maximum of five secretarial line units can be mounted on one switchboard position. The YW1 secretarial line unit provides nonlocking line signals with secrecy or nonsecrecy. Secrecy feature prevents the bureau attendant from gaining access to an established subscriber conversation and from making outgoing calls on a secretarial line. To provide the secrecy option, the SW1 screw switch on the YW1 circuit pack should be turned down to a closed position. The solid-state secretarial line unit (Fig. 4) is ordered separately and installed locally. The YW1 circuit pack requires a +5 volt dc power supply in addition to the standard -24 volt dc power supply. Unequipped secretarial line unit spaces in the face of the switchboard shall be covered with line unit blank (comcode 813415833) which is also ordered separately and installed locally. Each secretarial unit is 3-inches high and extends the full width of the switchboard jack panel opening. The secretarial line units are installed and removed from the rear of the switchboard and connected to the outgoing terminal strip through two plugs mounted on each side of the unit and sockets wired to the local switchboard cable. Two plugs, one on each side of the line units, are the power connectors for the +5 volt dc power supply.◀

◀CONCENTRATOR-IDENTIFIER EQUIPMENT

2.08 A secretarial line circuit unit consisting only of jacks, lamps, designation strips, and cable connectors is available for use with the concentrator-identifier equipment.◀

STATION LINES

2.09 A space of 4-1/8 inches at the bottom of the switchboard jack panel opening is arranged for trunks and station lines using individually mounted or strip-mounted jacks. The capacity for station lines will be 20 if the jacks and lamp sockets are mounted 10 per strip, and 40 if mounted 20 per strip. Jacks, lamp sockets, designation strips, and

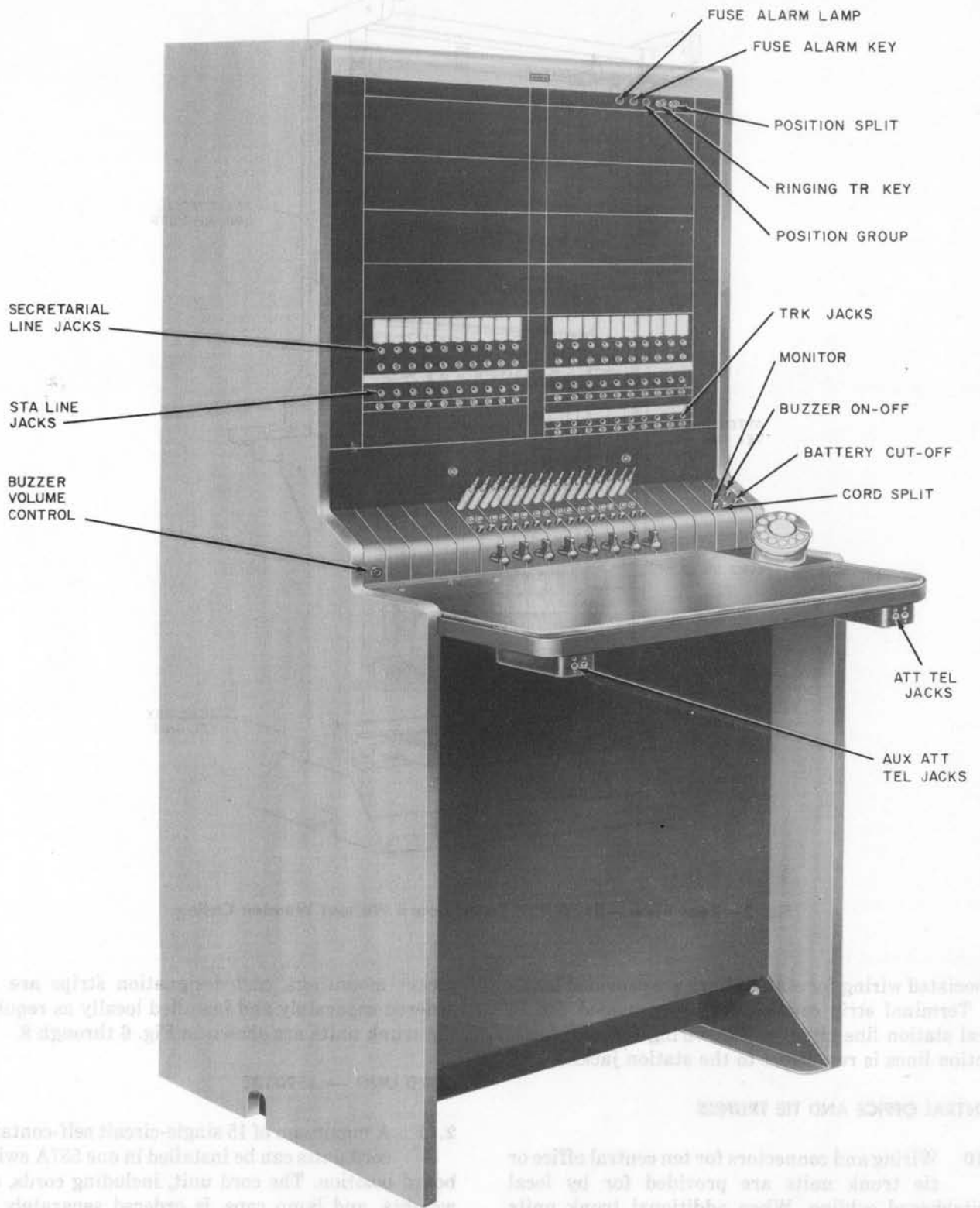

Fig. 1—557A PBX Switchboard

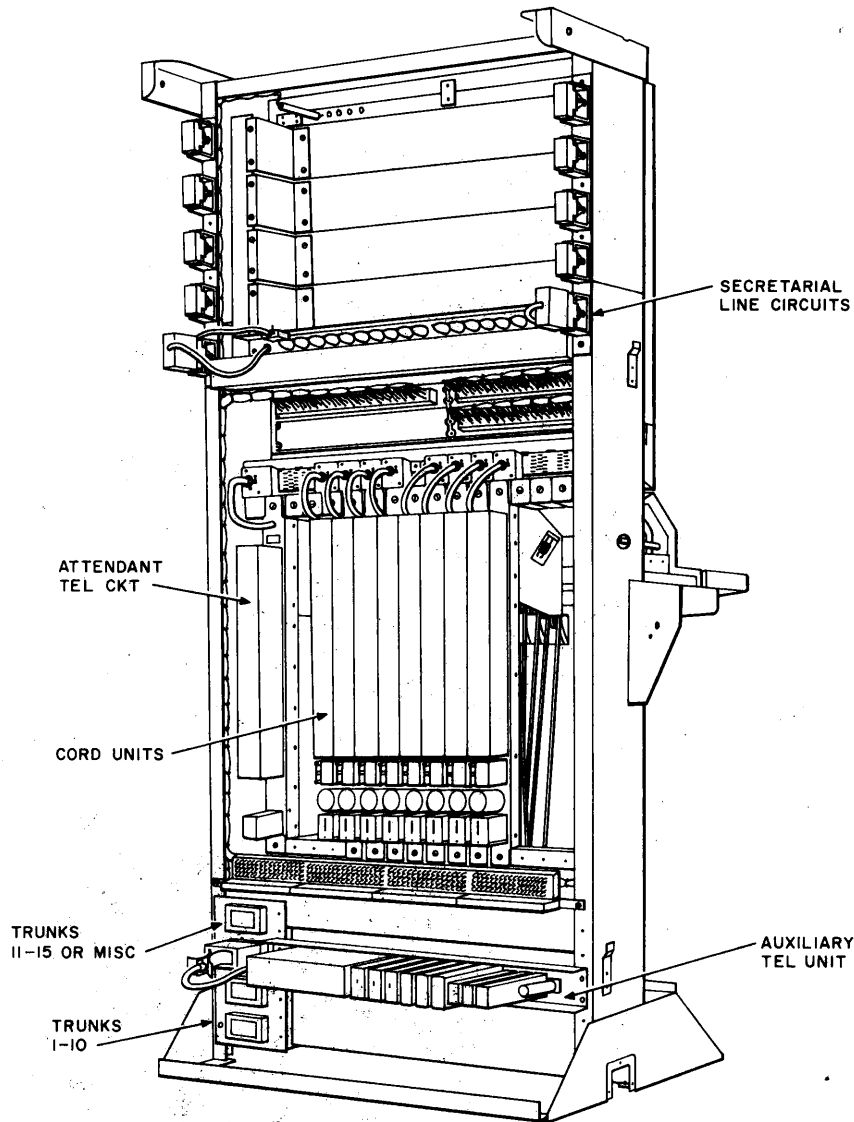

Fig. 2—Rear View—557A PBX Switchboard Without Wooden Casing

associated wiring for station lines are provided locally. Terminal strip connections are provided for 16 local station line circuits. The wiring for additional station lines is run direct to the station jacks.

CENTRAL OFFICE AND TIE TRUNKS

2.10 Wiring and connectors for ten central office or tie trunk units are provided for by local switchboard cabling. When additional trunk units are required, the wiring and connectors for trunks 11 through 15 shall be ordered separately and installed locally. Trunk units, associated jack mountings, lamp

socket mountings, and designation strips are also ordered separately and installed locally as required. Tie trunk units are shown in Fig. 6 through 8.

CORD UNIT — J59013E

2.11 A maximum of 15 single-circuit self-contained cord units can be installed in one 557A switchboard position. The cord unit, including cords, cord weights, and lamp caps, is ordered separately and installed locally in the switchboard framework as required. Unequipped cord unit positions shall be provided with cord blanks P-185039 (comcode

TABLE A

557A PBX SINGLE POSITION CAPACITY

EQUIPMENT	CAPACITY	WIRED
Secretarial Lines (Paragraphs 2.06, 2.07)	100	100
Station Lines (Paragraph 2.09)	40	—
Central Office (Paragraph 2.10)	15	10
Cord Circuits (Paragraph 2.11)	15	15
Auxiliary Telephone (Paragraph 2.12)	1	1

801850397), which are also ordered separately and installed locally. The cord unit normally furnished is arranged for through supervision, but may be converted to nonthrough supervision by insulating certain contacts of the RB relay with plastic sleeves. Sixty plastic sleeves are furnished with the basic switchboard inside the rear cover. For multiposition installations, long cords may be provided by replacing the standard length cords and weights (Fig. 9).

All connections to the cord units are made via plugs which make contact with one of the two bus-bar connectors located in the rear section of the switchboard. The standard cord unit is shown in Fig. 10.

AUXILIARY TELEPHONE CIRCUIT

2.12 An auxiliary telephone circuit, without dial, is furnished for use by a second attendant during peak load periods. The unit is located on a mounting plate in the bottom rear section of the switchboard (Fig. 2) and is under the control of the position-splitting key. The attendant telephone jack for the unit is located under the writing shelf on the left side.

MANUAL CONFERENCE CIRCUIT (MD)

2.13 A manual conference circuit (MD) per SD-66531-01, ordered separately and installed locally, may be used with the 557A PBX. Five conference jacks are furnished in the jack mounting face. The first three jacks are for station connections, while the last two jacks are for trunk or station connections (Fig. 11). A separate cord circuit is used for each station or trunk connected for conference. The jack mounting face is mounted in place of five central office trunk jacks. The wiring and connecting cable shall be made up and installed locally.

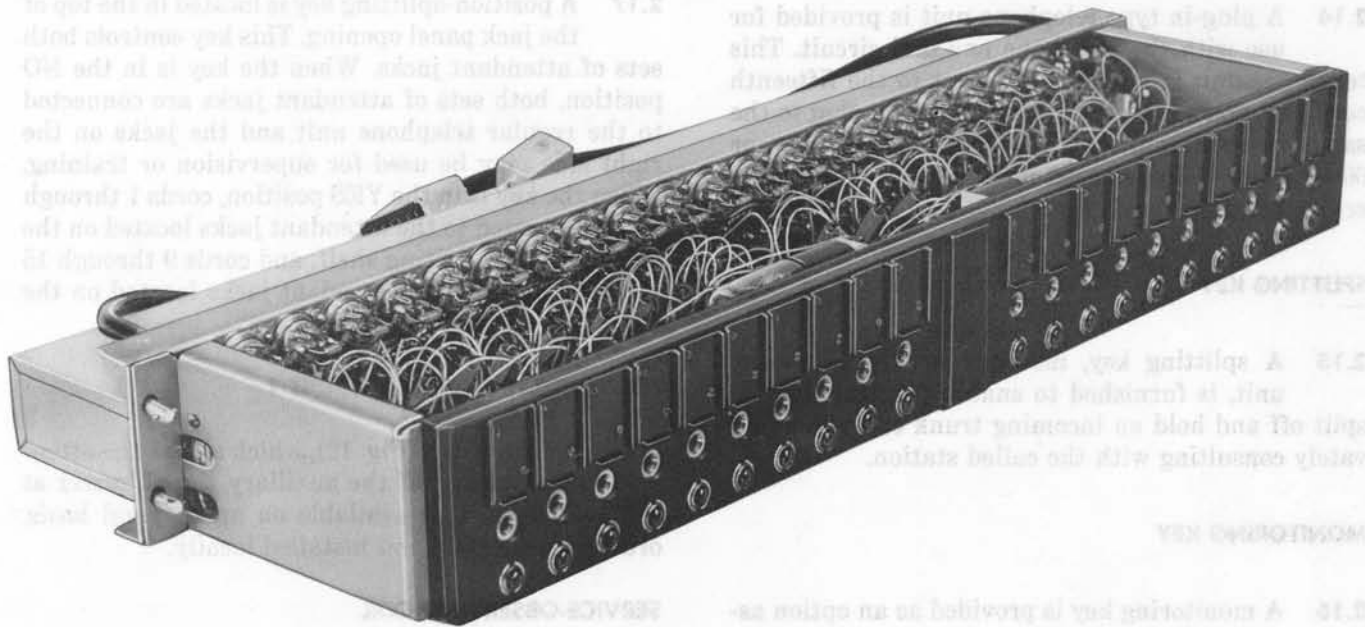

Fig. 3—J59023G-1 (MD) Electromechanical Secretarial Line Unit

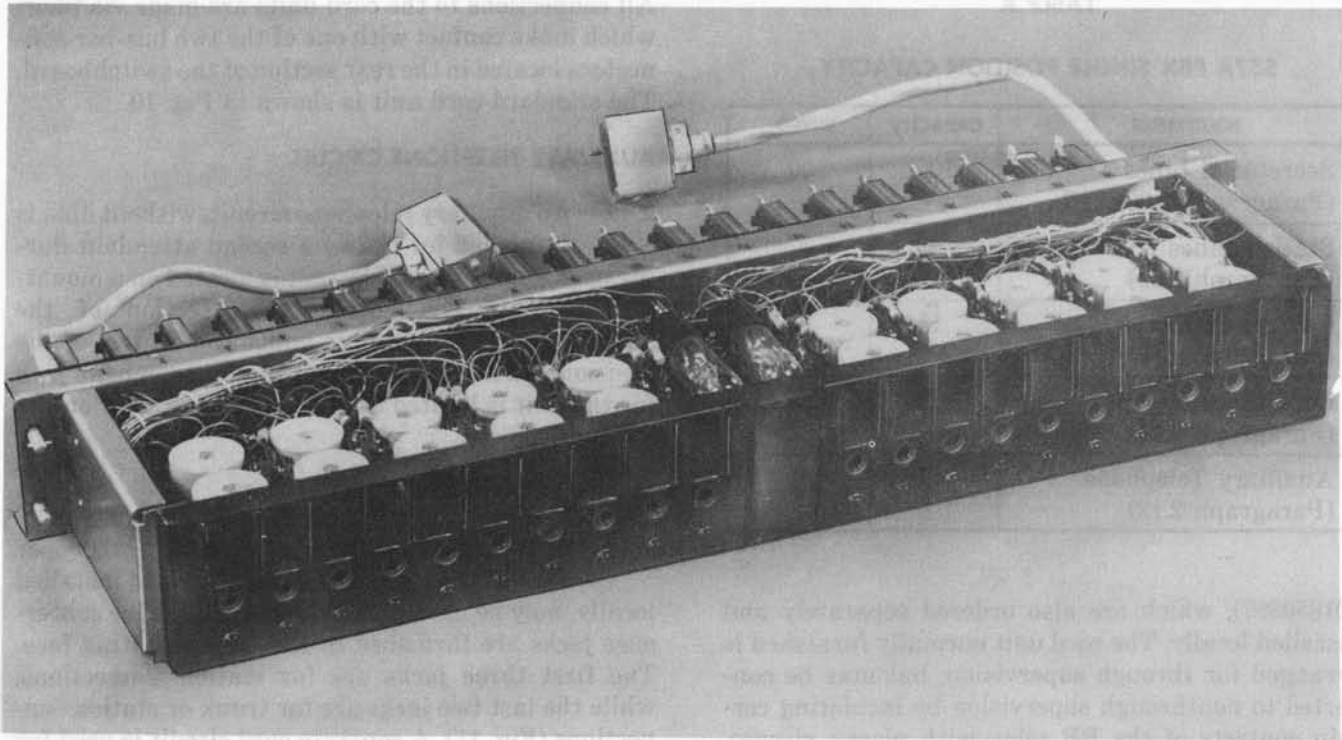

Fig. 4—J59023G-2 Solid-State Secretarial Line Unit

TELEPHONE CIRCUIT — J59013D

2.14 A plug-in type telephone unit is provided for use with the telephone and dial circuit. This telephone unit is mounted adjacent to the fifteenth cord unit and connects to the cords via a plug to the same bus-bar connector. A handset, 52-, 53-, or 60-type head telephone set may be used with the operator telephone jack.

SPLITTING KEY

2.15 A splitting key, mounted on the telephone unit, is furnished to enable the attendant to split off and hold an incoming trunk call while privately consulting with the called station.

MONITORING KEY

2.16 A monitoring key is provided as an option associated with the telephone unit to allow the attendant to monitor on any busy station line or trunk.

POSITION-SPLITTING KEY

2.17 A position-splitting key is located in the top of the jack panel opening. This key controls both sets of attendant jacks. When the key is in the NO position, both sets of attendant jacks are connected to the regular telephone unit and the jacks on the right side may be used for supervision or training. When the key is in the YES position, cords 1 through 8 are connected to the attendant jacks located on the left side of the writing shelf, and cords 9 through 15 are connected to the attendant jacks located on the right side of the writing shelf.

FOOTSWITCH — KS-16821, LIST 1

2.18 A footswitch (Fig. 12), which allows the attendant to cut off the auxiliary signal buzzer at the switchboard, is available on an optional basis, ordered separately and installed locally.

SERVICE-OBSERVING COIL

2.19 A service-observing coil which, when connected to the attendant telephone and dial

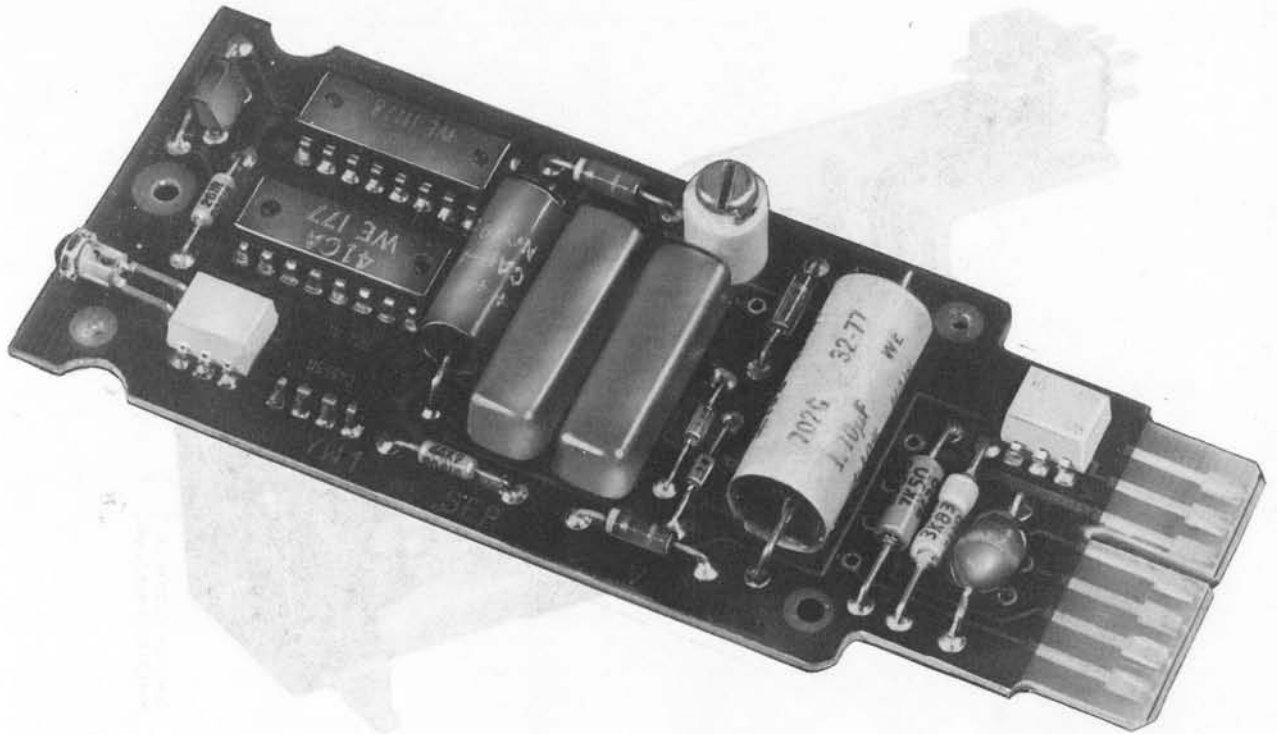

Fig. 5—YW1 Solid-State Circuit Pack

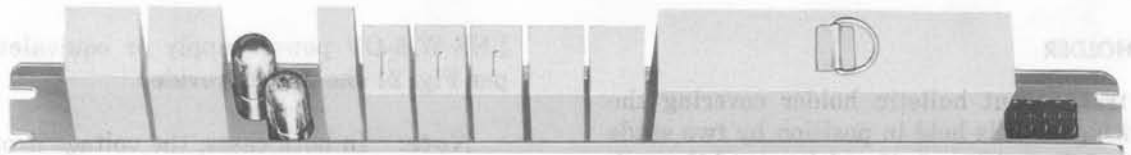

Fig. 6—J59013H,L2 (MD) Tie Trunk Relay Unit

unit, permits service-observing by a telephone answering manager or chief operator, is available on an optional basis. Service-observing does not include monitoring on the auxiliary telephone circuit when two attendants are operating one position.

DIAL AND DIAL MOUNTING

2.20 The dial and dial mounting are not furnished as part of the basic switchboard. They are ordered separately and installed locally when required. The dial is mounted on the right side of the writing shelf at a convenient operating angle toward the rear. One of two rotary dials may be used: the

No. 6R-3 dial when 10 pulses per second are desired, and the No. 6G dial when 20 pulses per second are desired. A rotary card dialer (MD) (Fig. 13) or a TOUCH-TONE calling card dialer (MD) (Fig. 14) is also available for mounting on the right-hand side of the writing shelf. Both the rotary and TOUCH-TONE calling card dialers (MD) are ordered separately, assembled, and installed locally. To provide TOUCH-TONE calling, a dial assembly, dial mounting, and dial auxiliary unit must be ordered separately and installed locally. The dial assembly mounts on the surface of the writing shelf in the space normally occupied by the rotary dial. The dial auxiliary unit mounts directly on the telephone unit.

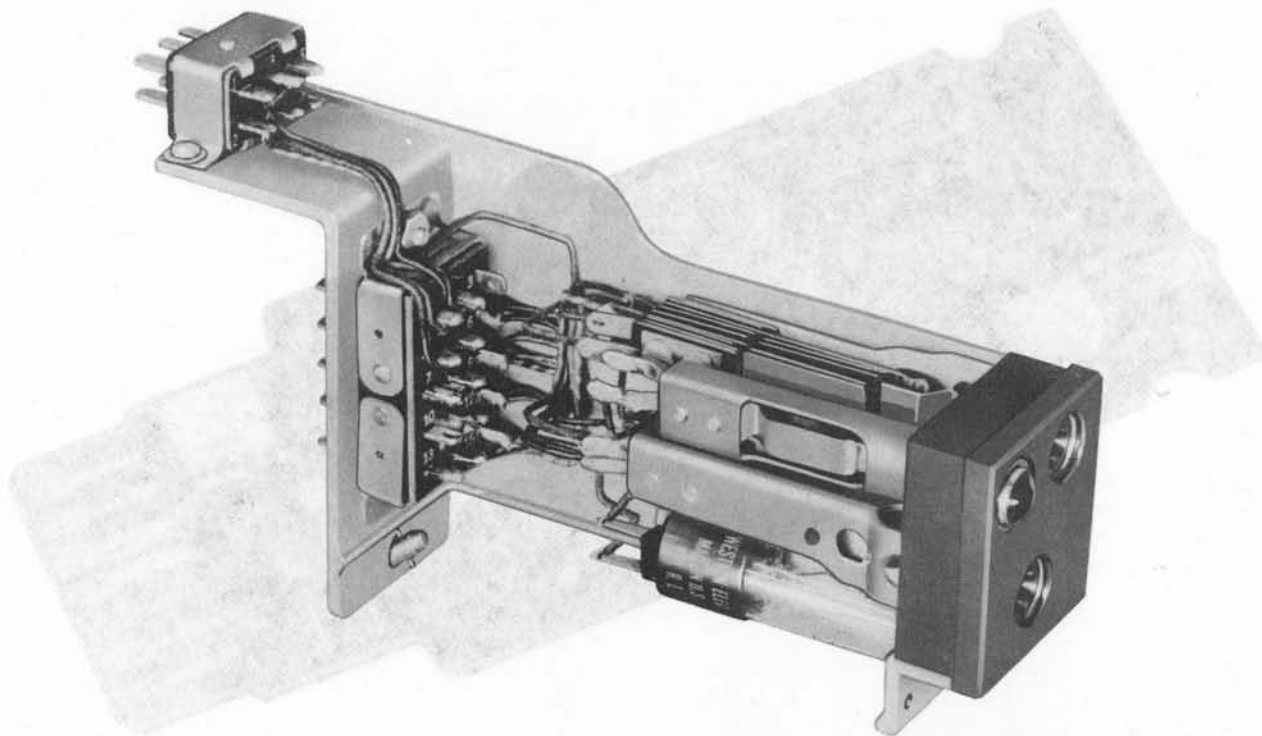

Fig. 7—J59013H, L2 (MD) Tie Trunk to Dial PBX Jack Unit

BULLETIN HOLDER

2.21 A transparent bulletin holder covering the writing shelf is held in position by two studs in the rear of the writing shelf which extend through matching holes in the transparent holder. This permits the attendant to remove the holder and change bulletins without the use of tools.

BATTERY SUPPLY

2.22 ♦The switchboard may be powered either from a -48 volt dc central office battery via cable conductors or from a local -24 volt dc power supply. When the YW1 secretarial line circuit pack is provided, a +5 volt dc power supply is also required. The +5 volt direct current can be obtained by one of the following methods:

- (a) If a -24 volt dc standby power source is available, two 120C converters wired per Fig. 24 should be provided.
- (b) If a -24 volt dc standby power source is not available, a +5 volt dc PS Lambda No.

LNS-W-5-0V power supply or equivalent wired per Fig. 24 should be provided.

Note: In both cases, the voltage drop on the +5 volt dc switchboard feeder cable between the power source and the YW1 circuit pack shall not exceed 0.25 volts. Current drain for each YW1 circuit pack is 100 mA maximum at +5 volt direct current. A +5 volt dc fuse alarm lamp must be locally engineered and installed.♦

FUSE ALARM CIRCUIT

2.23 A fuse alarm circuit, equipped with an alarm lamp and an alarm cutoff key, is available on an optional basis for installations using a local power plant with fuse panel. When this option is provided, the alarm lamp and alarm cutoff key are mounted in a panel at the top of the jack panel opening.

RINGING CURRENT

2.24 Ringing current is normally furnished over cable pairs from the central office or by a

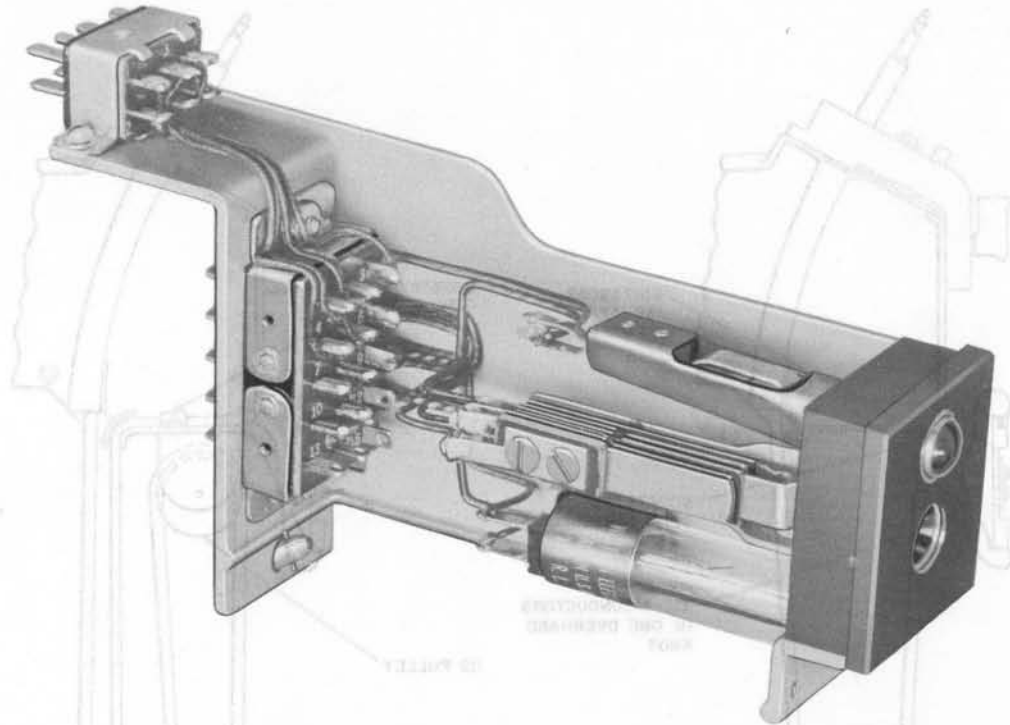

Fig. 8—J59013J (MD) Automatic Tie Trunk Jack Unit

KS-5585 frequency converter located on the customer premises. A hand generator for emergency use is not furnished as part of the basic switchboard. An externally mounted hand generator is available on an optional basis for mounting on the side panels at either the right or left side of the attendant. When the hand generator is provided, a ringing transfer key is mounted in the panel at the top of the jack panel opening.

SECRETARIAL LINE TEST LAMP

2.25 A secretarial line lamp test circuit is available to the attendant. Depressing one of five keys (one per 20 lamps) will light the associated 20 lamps. Failure of the lamps to light indicates an inoperative circuit. Replacement of the defective lamp(s) will restore the circuit to normal.

BATTERY CUTOFF KEY

2.26 A battery cutoff key is available on an optional basis for removal of battery from the entire switchboard including associated secretarial line equipment, central office trunks, and tie trunk

equipment. A wiring option is provided to permit battery on the tie trunk equipment at all times.

INTERPOSITION TRUNKS

2.27 Interposition trunks are available on an optional basis to provide assistance to or from an adjacent operator, when required.

ZIPTONE UNIT — J59023K

2.28 A ziptone tone circuit is available for concentrator-identifier equipped switchboards to indicate to the attendant that a connection to the central office has been established.

EQUIPMENT SUMMARY

2.29 Table B summarizes the equipment by manufacturing codes for the 557A PBX.



Do not use this practice for ordering information. See Section 809-720-150.

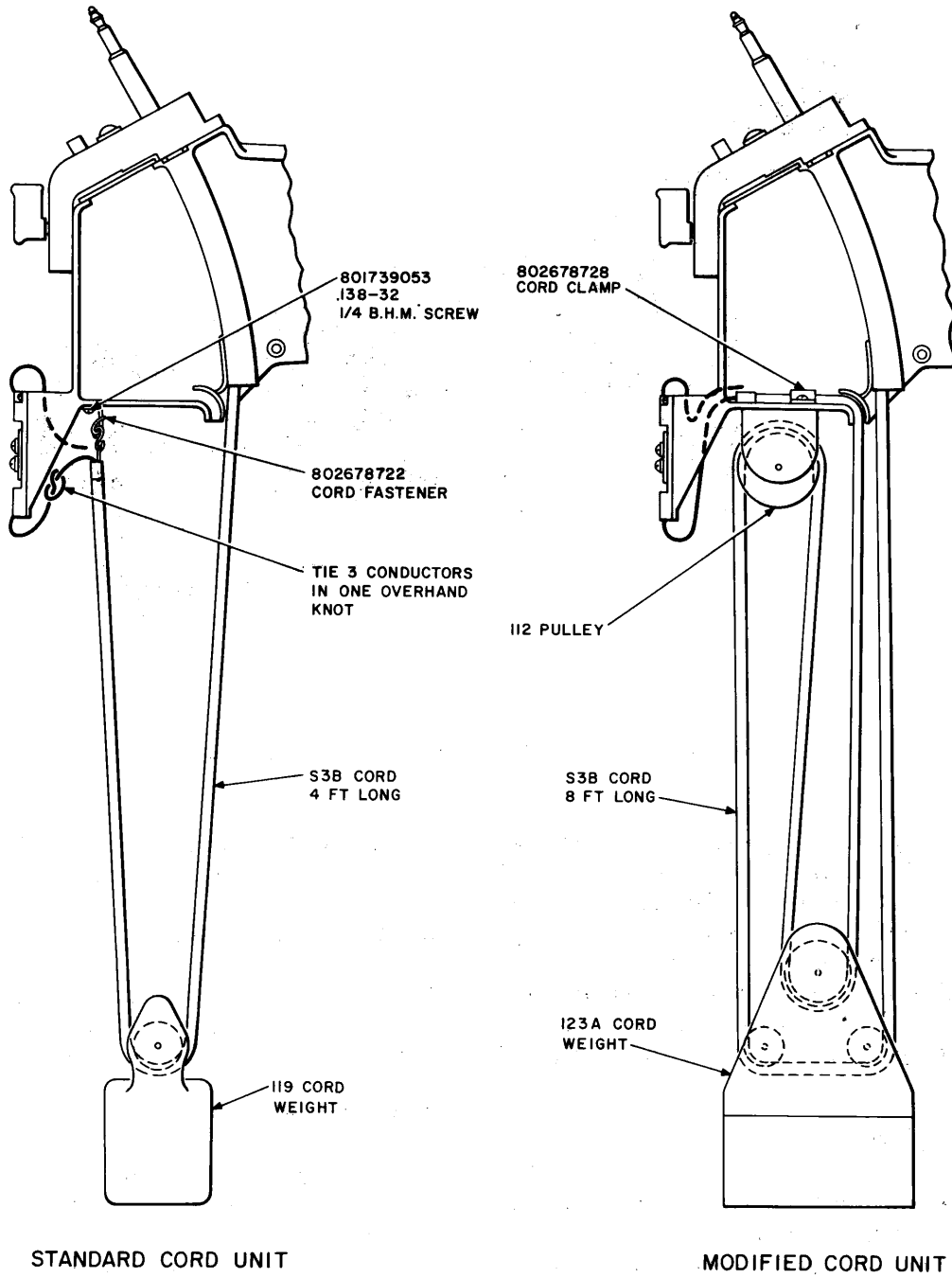

Fig. 9—Modification of Cord Unit

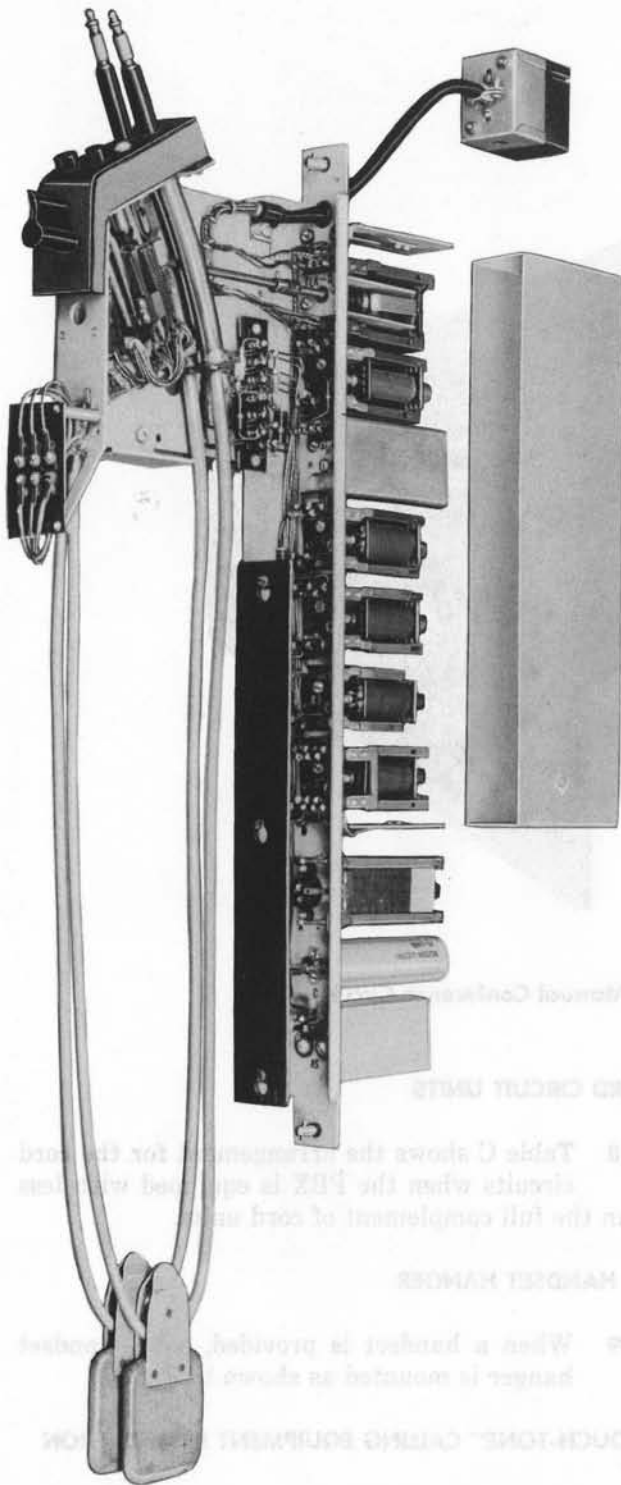

Fig. 10—J59013E Cord Unit

3. INSTALLATION

UNPACKING

3.01 The 557A PBX should be unpacked and assembled as near as possible to the selected location to prevent damage to the equipment during unpacking and installation. When moving or carrying the PBX, precautions should be taken to guard against personal injury.

LOCATION

3.02 Place the PBX in the location designated by the job instructions and customer approval. The location should be free from excess dust, corrosive fumes, excessive vibration due to machinery, etc. The back of the PBX shall not be less than 30 inches from the wall or any other obstruction. There should be a minimum clearance of approximately 40 inches in front of the writing shelf for operating purposes.

3.03 The switchboard should be located so natural or artificial light will not make it difficult for the attendant to see the lamp signals. If a desirable location is not available, the customer should be advised that the light will affect the visibility of the lamp signals and that steps should be taken to reduce the light by shades or other suitable means. The location selected for the PBX should have an electrical outlet reasonably nearby.

3.04 When the PBX is to be installed on a metal surface, such as on inserts used for terrazzo floors, insulate the framework with insulating strips (Fig. 15).

3.05 When the PBX is to be installed on a floor covered with an insulating material, such as rubber tile, though metal may be concealed under the insulating material, no insulating strips are required. The fiber floor insulator washers furnished with the PBX will provide the necessary insulation for the PBX framework.

3.06 The PBX should be fastened to the floor as shown in Fig. 16 and should stand approximately level.

Caution: Do not drill cement floors containing radiant heat. For installations of this type, place the PBX on a rubber mat or some other nonskid or adhesive material to prevent the PBX from sliding.

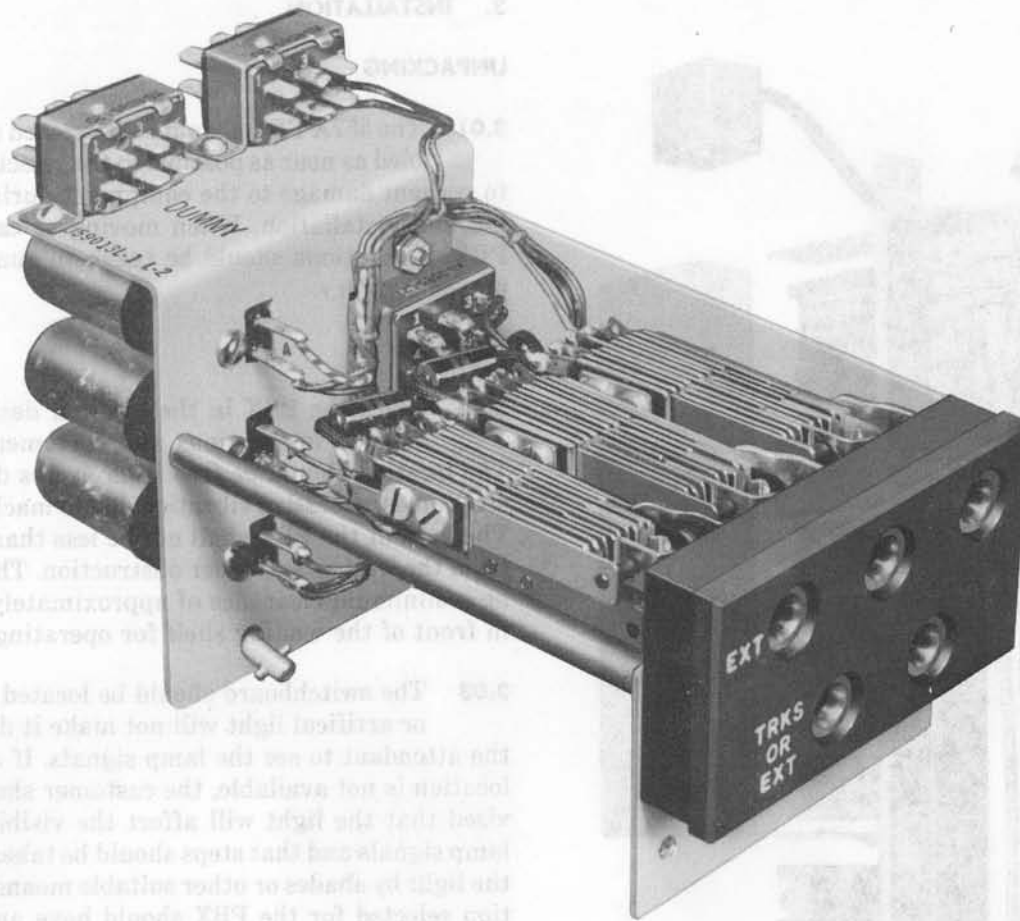

Fig. 11—J59013L (MD) Jack Unit for Manual Conference Circuit

MULTIPOSITION INSTALLATION

3.07 When installing the 557A PBX as a multiposition, perform the following steps:

- (1) Perform the work operations outlined in paragraphs 3.01 through 3.06.
- (2) Modify one side panel as shown in Fig. 17 and use it to separate the adjacent positions.
- (3) Before aligning the positions, remove the casing mounting clips from the side of the position which is to be butted against the finished side of the modified panel being used as the separator. Align the positions and bolt them together, using the hardware shown in Fig. 17 or equivalent.
- (4) Modify the standard cord unit using an 8-foot cord as shown in Fig. 9.

CORD CIRCUIT UNITS

3.08 Table C shows the arrangement for the cord circuits when the PBX is equipped with less than the full complement of cord units.

9A HANDSET HANGER

3.09 When a handset is provided, a 9A handset hanger is mounted as shown in Fig. 18.

"TOUCH-TONE" CALLING EQUIPMENT INSTALLATION

Removal of Rotary Dial and Installation of 50A Dial Mounting for TOUCH-TONE Calling Dial

3.10 To remove the rotary dial and install the 50A dial mounting for the TOUCH-TONE calling dial, perform the following steps:



Fig. 12—KS-16821, L1 Footswitch

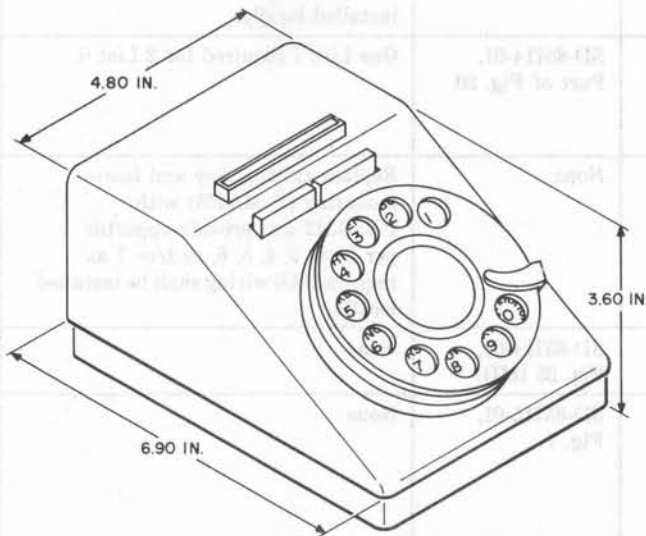

Fig. 13—Rotary Calling Card Dialer (MD)

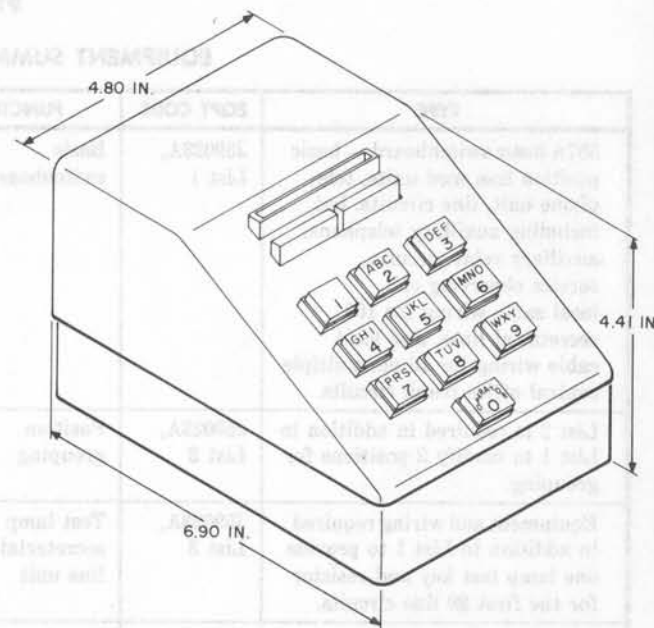

Fig. 14—TOUCH-TONE Calling Card Dialer (MD)

- (1) Remove the front panel of the 557A switchboard and disconnect the KS-8586, List 31 dial and telephone socket from under the writing shelf of the PBX.
- (2) Remove the rotary dial, dial mounting, and connecting block.
- (3) Cut the leads near the terminals of the connecting block and draw them through the underside of the writing shelf.
- (4) Assemble the 50A dial mounting bracket on the writing shelf (Fig. 19).
- (5) Screw the KS-19087, List 5 connector to the 50A dial mounting bracket.

3.11 To install the dial auxiliary unit, remove the telephone unit from the PBX and mount the dial auxiliary unit into the telephone unit, as shown in Fig. 20.

3.12 To make connections for the TOUCH-TONE calling dial and auxiliary unit, perform the following steps:

- (1) Connect the KS-19087, List 5 connector on the TOUCH-TONE calling dial to the KS-8586,

TABLE B

EQUIPMENT SUMMARIZATION—557A PBX

TYPE	EQPT CODE	FUNCTION	SCHEMATIC	REMARKS
557A basic switchboard — basic position less cord units, telephone unit, line circuits, but including auxiliary telephone, auxiliary relay circuits, service observing coil, local cable wiring for 100 secretarial lines, and local cable wiring for 10 nonmultiple central office trunk circuits.	J59023A, List 1	Basic switchboard	SD-65714-01 SD-65715-01 SD-65727-01	The basic switchboard (List 1) does not include the wooden casing. The casing must be ordered separately per ED-65840-70 G-2.
List 2 is required in addition to List 1 to modify 2 positions for grouping.	J59023A, List 2	Position grouping	SD-65714-01, Fig. 17, 18, 19	Cord units must be provided with 8-foot cords.
Equipment and wiring required in addition to List 1 to provide one lamp test key and resistor for the first 20 line circuits.	J59023A, List 3	Test lamp secretarial line unit	SD-65727-01, Fig. 9, 10	None
Equipment and wiring required in addition to Lists 1 and 3 to provide a lamp test key for each additional 20 line circuits.	J59023A, List 4	Test lamp secretarial line unit	SD-65727-01, Fig. 9	None
Equipment and wiring required in addition to List 1 to provide battery cutoff key.	J59023A, List 5	Battery cutoff key	SD-65714-01, Fig. 22	None
Equipment and wiring required in addition to List 1 to provide interposition (teamwork) trunks to an adjacent position (maximum 2, List 6).	J59023A, List 6	Interposition	SD-65714-01, Fig. 20, 21	When interposition trunks are required for each adjacent position, furnish 2 List 6. Wiring for battery and ground only is provided in the local cable. Wiring between jacks of adjacent positions shall be installed locally.
Equipment and wiring required in addition to List 6 to provide a battery supply resistance lamp.	J59023A, List 6	Interposition	SD-65714-01, Part of Fig. 20	One List 7 required for 2 List 6.
Equipment required when Lists 3, 4, 5, 6, and/or 7 are to be applied to an existing switchboard on which List H was not furnished.	J59023A, List 8	—	None	Replace existing key and lamp mounting (P-34A423) with P-48G342 and provide apparatus per Lists 3, 4, 5, 6, and/or 7 as required. All wiring shall be installed locally.
Apparatus and equipment required for rotary card dialer.	J59023A, List 9	Rotary dial card dialer	SD-65714-01, Fig. 25 (MD)	None
Required in addition to List 1 to provide wiring for 10 central office trunk jacks and lamp connections for trunks per J59023E-2 to replace similar wiring in List 1 central office trunks per J59023E-1.	J59023A, List E	—	SD-65715-01, Fig. 7	None

♦TABLE B♦ (Contd)

EQUIPMENT SUMMARIZATION—557A PBX

TYPE	EQPT CODE	FUNCTION	SCHEMATIC	REMARKS
Equipment always required in addition to List 1 and 3.	J59023A, List H	—	—	None
Always required in addition to List 1.	J59023A, List J	—	SD-65714-01, Fig. 27	None
Writing shelf assembly (this list is not ordered in List 1).	J59023A, List K	—	SD-65714-01, Fig. 7, 8	List K is not part of List 1.
Always required in addition to List 1.	J59023A, List L	—	SD-65714-01, Fig. 3, 4, 11	None
Always required in addition to List 1.	J59023A, List M	—	SD-65714-01, Fig. 6	None
Wiring and equipment always required in addition to List 1 to provide 100 secretarial lines, 5-volt arrangement for FCC registration.	J59023A, List N	—	SD-65727-01, Fig. 16, 17, 18	None
Equipment and wiring for line relay, fuse alarm, and auxiliary signal unit.	J59023D, List 1 List 2 List 3 List 4	Line relay, fuse alarm, and auxiliary signal unit	SD-65714-01, Fig. 13, 16	A maximum of 7 line relays per List 4 may be mounted on the plate furnished in List 1.
Equipment and wiring required for 5 circuit nonmultiple central office trunk circuit.	J59023E, List 2	Nonmultiple central office trunk unit	SD-65715-01, Fig. 7	Unit provided with 35 point connector.
Equipment and wiring required for multiple central office trunk.	J59023F, List 1	Multiple central office trunk unit	SD-65715-01, Fig. 2	Unit occupies space of 2- by 23-inch mounting plate.
Equipment and wiring for one unit of 20 secretarial line circuits.	J59023G-1, List 1 (MD)	Electromechanical secretarial line unit	SD-65727-01, Fig. 1, 4	Nonlocking with secrecy ac-dc or negative superimposed ringing.
Equipment and wiring for one unit of 20 secretarial line circuits.	J59023G-1, List 2 (MD)	Electromechanical secretarial line unit	SD-65727-01, Fig. 2, 4, Options S and R	Nonlocking with secrecy ac only or positive superimposed ringing.
Equipment and wiring for one unit of 20 secretarial line circuits.	J59023G-1, List 3 (MD)	Electromechanical secretarial line unit	SD-65727-01, Fig. 3, 4	Nonlocking with secrecy positive and negative superimposed or other type ringing.
Equipment and wiring always required for one unit of 20 concentrator identifier lines.	J59023G-2, List 6	Concentrator identifier line jack equipment	SD-65727-01, Fig. 5	None
Universal secretarial line circuit arranged for nonlocking lamp signal and secrecy and non-secrecy.	J59023G-2, List 7	Secretarial line equipment for 20 solid- state line circuits	SD-65727-01, Fig. 11	None

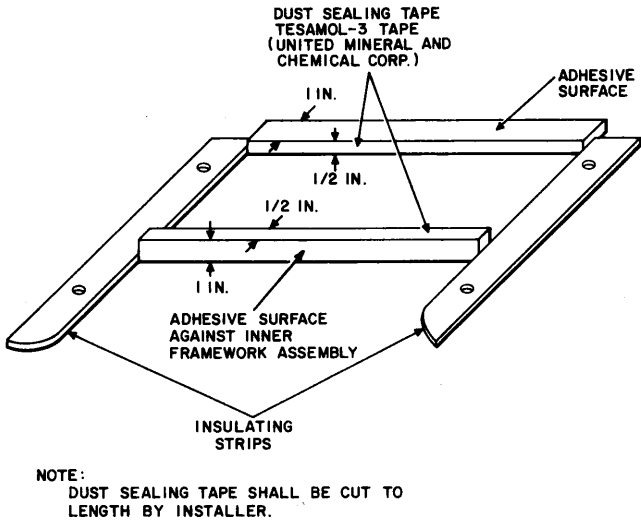

Fig. 15—Placement of Insulating and Dust Sealing Strips

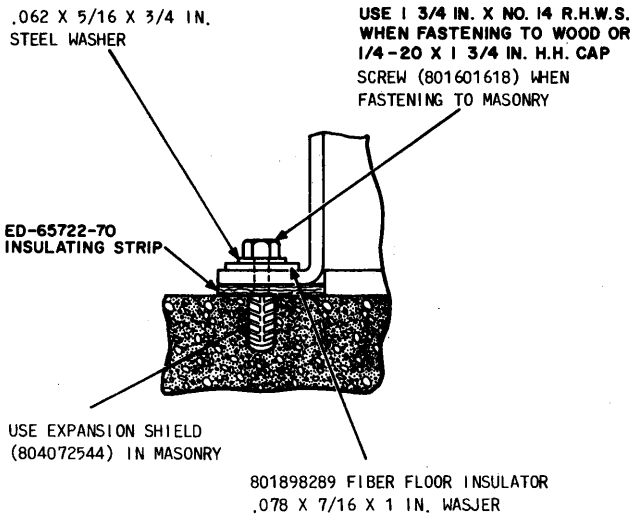

Fig. 16—Fastening the PBX to the Floor

List 31 dial and telephone socket, by splicing and taping the leads from the KS-19087 connector (1 Fig. 21) to the leads of the KS-8586 socket that were previously cut near the terminals of the rotary dial connect block.

(2) Remove wire from terminals 1 and 3 of the KS-8585, List 18 plug on the telephone unit and connect to terminal 21 of the TOUCH-TONE dialing auxiliary unit (2 Fig. 21).

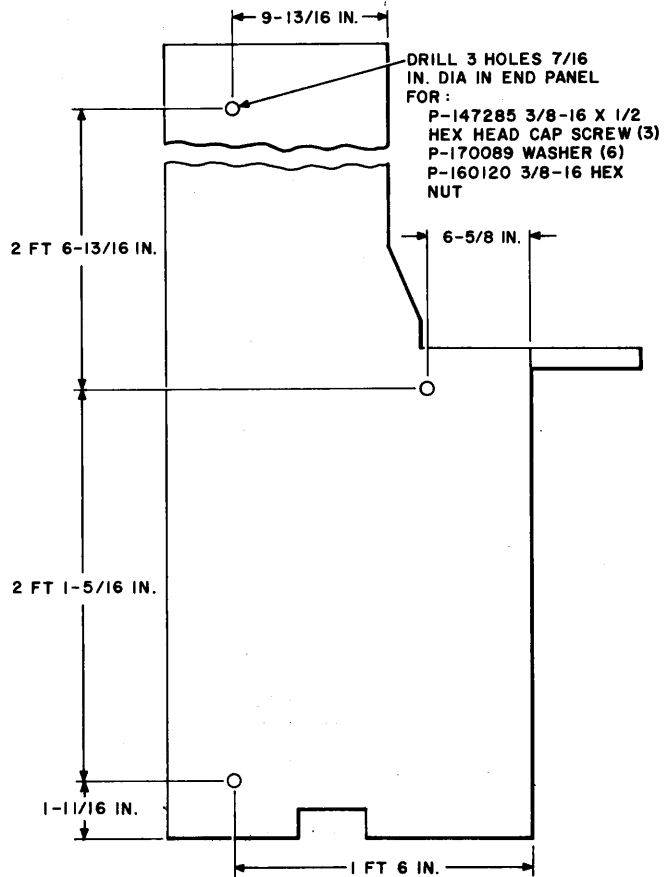

Fig. 17—Separation Panel Modification Detail

(3) Remove wire from terminals 4 and 5 of the KS-8585, List 18 plug and splice together (3 Fig. 21).

(4) Remove wires from terminal 2 of the KS-8585, List 18 plug and connect to terminal 8 of the TOUCH-TONE dialing auxiliary unit (4 Fig. 21).

(5) Connect battery from terminal 7B on SP relay to terminal 5 of the TOUCH-TONE dialing auxiliary unit, using option E for 30 to 50 volts (5 Fig. 21).

(6) Connect leads from terminals 1 and 3 of the 348A plug to either terminals 10 and 13 on the auxiliary unit or, if the grouping circuit is used, connect leads from terminals 1 and 3 of the 348A plug to terminals 3T and 3B of the G1 relay (6 Fig. 21).

TABLE C
CORD UNIT INSTALLATION SEQUENCE

Number of Cords	CORD UNIT POSITION NUMBERS														
	1	2	3	4	5	6	7	8	9	10	11	12	13	14	15
3							R	S	R						
4							R	S	R	S					
5						S	R	S	R	S					
6						S	R	S	R	S	R				
7					R	S	R	S	R	S	R				
8					R	S	R	S	R	S	R	S			
9				S	R	S	R	S	R	S	R	S			
10				S	R	S	R	S	R	S	R	S	R		
11			R	S	R	S	R	S	R	S	R	S	R		
12			R	S	R	S	R	S	R	S	R	S	R	S	
13		S	R	S	R	S	R	S	R	S	R	S	R	S	
14	R	S	R	S	R	S	R	S	R	S	R	S	R	S	
15	R	S	R	S	R	S	R	S	R	S	R	S	R	S	R

R—red cord.

S—slate cord.

- (7) Remove wire between terminal 1 of the 348A plug and 2T of SP relay (7 Fig. 21).
- (8) Connect new wiring between terminals 1, 3, 5, 2, and 4 of the KS-8585, List 18 plug, to terminals 23, 3, 9, 33, and 30 of the auxiliary unit respectively (8 Fig. 21).
- (9) Connect a lead from terminal 9 of the auxiliary unit to terminal 2B of SP relay (9 Fig. 21).

3.13 Before remounting the converted telephone unit in the PBX, connect the 348A plug from the telephone unit to the 204B connector in the rear of the switchboard. Using a KS-14510 VO17 voltmeter, check the dc voltage between terminals 3 and 23 (GRD) of the TOUCH-TONE dialing auxiliary unit with a TALK and DIAL key operated. The voltage measured at terminal 3 should be +7 to +9 volts. Finish mounting the unit and connect the KS-8586, List 31 dial and telephone socket from the TOUCH-TONE calling dial unit to the KS-8585, List 18 plug on the telephone unit.

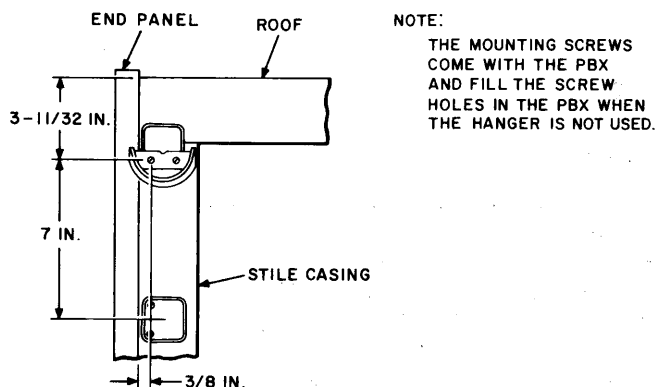

Fig. 18—Mounting 9A Handset Hanger

INSTALLATION OF "TOUCH-TONE" CALLING DIAL AND COVER

3.14 Plug in the TOUCH-TONE calling dial connector, mount and secure the TOUCH-TONE calling dial to the 50A dial mounting with the screws provided (Fig. 19B). Snap on the comcode 818939035 TOUCH-TONE telephone dial housing (Fig. 19C).

INSTALLATION OF "TOUCH-TONE" CALLING CARD DIALER (MD)

3.15 Packaged drawings describing the modifications necessary for installation of the TOUCH-TONE calling card dialers (MD) are included with List 1 of both J58850E and J58850F.

INSTALLATION OF ROTARY CARD DIALER (MD)

3.16 Necessary modifications to existing writing shelf and bulletin holder in order to install the rotary card dialer (MD) are shown in Fig. 22 and 23. The dial is not included in the stocklists for the conversion. In most instances, the standard dial will be available on the installation to be modified and will only need relocation.

FOOTSWITCH — KS-16821, LIST 1

3.17 The footswitch shall be installed locally, using 2-conductor 18-gauge Tirez wire or equivalent. Identification and connections for the footswitch are covered in Section 463-245-100.

ROTARY DIAL MOUNTING

3.18 Three black flathead screws are furnished with the writing shelf as apparatus blanks to

conceal the three holes used for installing the dial mounting. When a dial mounting is installed, the two 1-1/4 inch screws are reused to mount the dial mounting connector block. The 1-1/2 inch nut and washer are discarded.

4. CONNECTIONS

4.01 The size of the cross-connecting terminal box, the number of connecting blocks and fanning strips, and the size of the switchboard cable will vary with the number of secretarial lines, central office or tie trunks, station lines, and number of positions provided. Table D shows a typical assignment of cable pairs between the cross-connecting terminal box and the PBX terminal strips.

4.02 Run the cables in accordance with job instructions and practices covering the type of cables selected. Leave sufficient length for terminating at the ends and ample slack for storing, as required by local conditions. Any spare pairs should be left long enough to reach to the jack spaces provided for stations or trunks. These pairs may then be used for trunk and station lines in excess of those provided for in the local switchboard cabling.

4.03 The cable may enter the PBX either through the cable entrance holes provided at the side of the PBX or through the floor as required.

4.04 Before connecting the battery feeders through to the PBX, test them for the following proper conditions:

- (a) See that the feeders from the central office or building battery have been properly terminated up to the PBX cross-connecting point. When the supply is from building battery, see that the proper fusing has been provided at the fuse panel adjacent to the building battery.
- (b) At the cross-connecting point nearest the PBX, connect a voltmeter to the cable which is connected to the battery supply and verify that battery is present and properly poled.

4.05 At battery punchings on TS strip at PBX, strap terminals 4 to 5, 3 to 11, and 15 to 16. If battery cutoff key is not required, at battery punchings of TS at PBX, strap terminals 1 to 4, 2 to 3, and 14 to 16.

4.06 Installation of the solid-state YW1 secretarial line circuit pack requires a +5 volt dc power

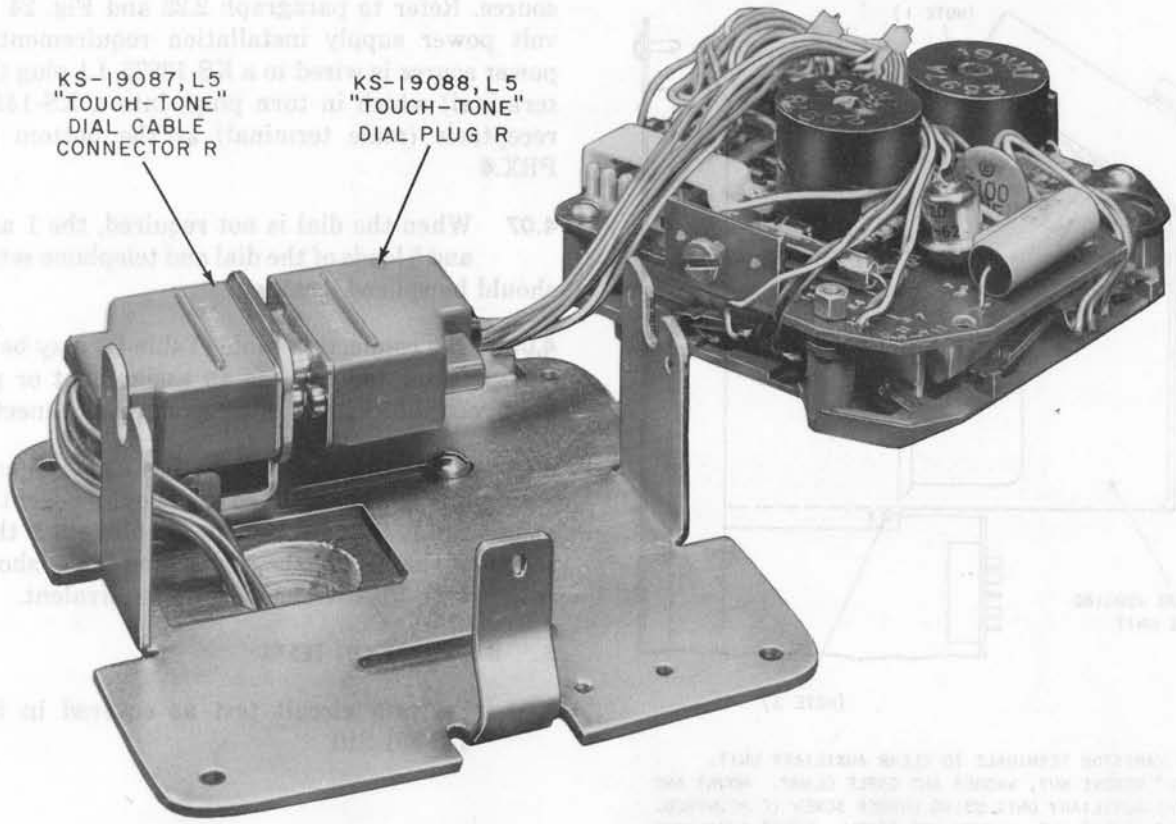

A-BRACKET OF 50C-3 DIAL MOUNTING



B-50C-3 DIAL MOUNTING WITH A 35-TYPE DIAL (HOUSING REMOVED)

C-50C-3 DIAL MOUNTING WITH A 35-TYPE DIAL

Fig. 19—50A Dial Mounting and Associated TOUCH-TONE Calling Dial

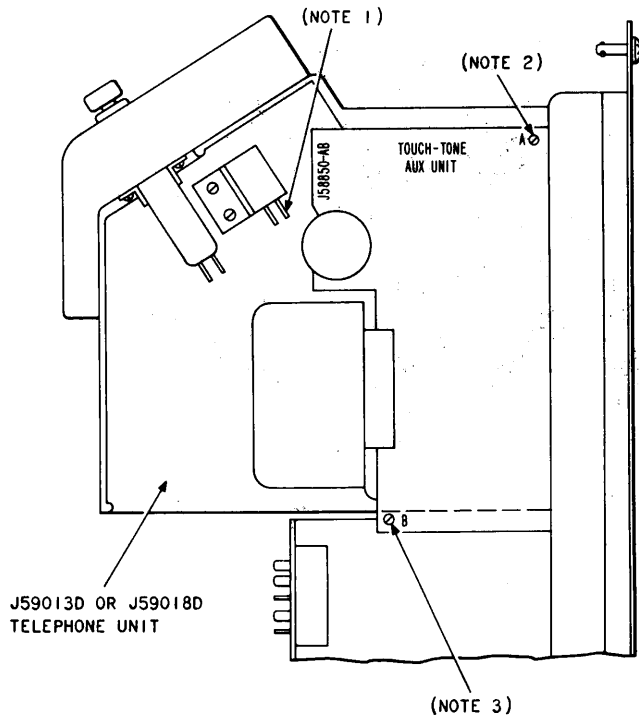

NOTES:

1. BEND VARISTOR TERMINALS TO CLEAR AUXILIARY UNIT.
2. AT "A" REMOVE NUT, WASHER AND CABLE CLAMP. MOUNT AND SECURE AUXILIARY UNIT USING LONGER SCREW IF REQUIRED.
3. AT "B" REMOVE NUT, WASHER AND SCREW. MOUNT AUXILIARY UNIT AND SECURE WITH 0.138 -32 X .500 IN. FHMS.

Fig. 20—Assembly of TOUCH-TONE Dialing Auxiliary Unit Into Telephone Unit of 557A PBX

source. Refer to paragraph 2.22 and Fig. 24 for +5 volt power supply installation requirements. The power source is wired to a KS-13875, L1 plug (female terminal) which in turn plugs into a KS-14160, L1 receptacle (male terminal) at the bottom of the PBX.⚡

4.07 When the dial is not required, the 1 and 3, 4 and 5 leads of the dial and telephone set socket should be spliced locally.

4.08 The connection table (Table D) may be reproduced and used as an assignment or permanent record of PBX cabling and cross-connecting.

4.09 After the cables have been placed and fastened, the fiber cover should be cut to fit snugly around the cable. When cables enter the PBX through the floor, the remaining hole should be sealed with Plastic Duct Seal or equivalent.

5. INSTALLATION TESTS

5.01 Perform circuit test as covered in Section 473-601-210.

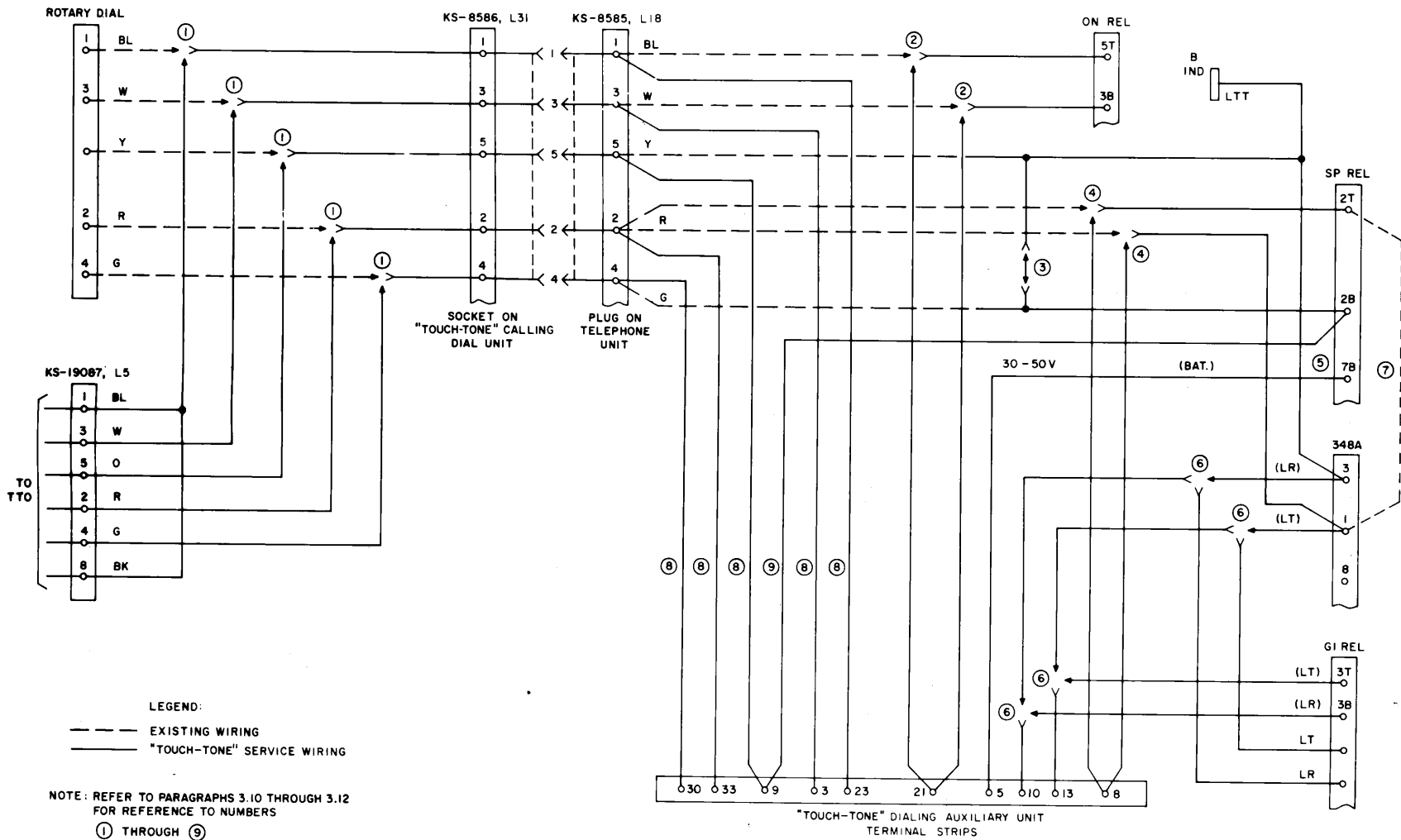

Fig. 21 — TOUCH-TONE Dialing Equipment Connections for 557A PBX

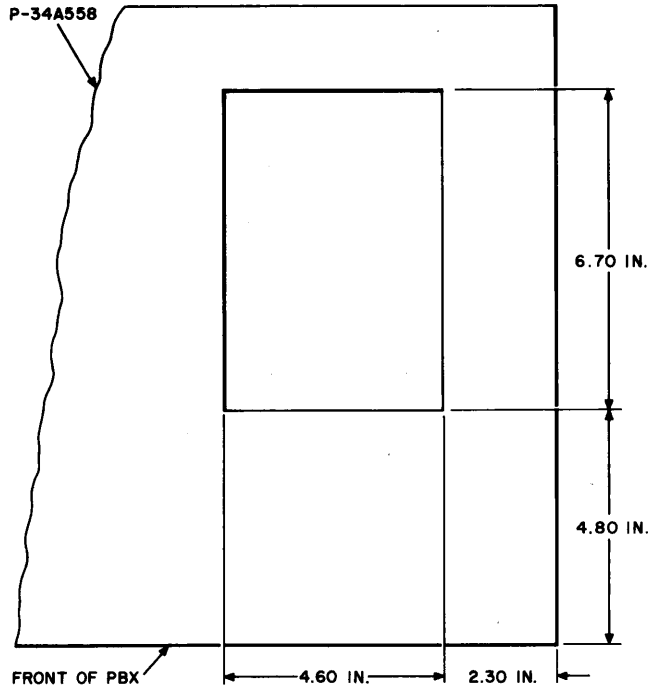

Fig. 22—Modification of Writing Shelf for Rotary Card Dialer (MD)

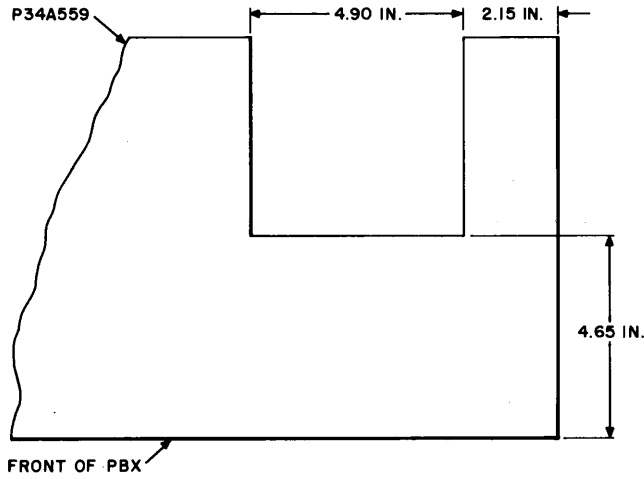
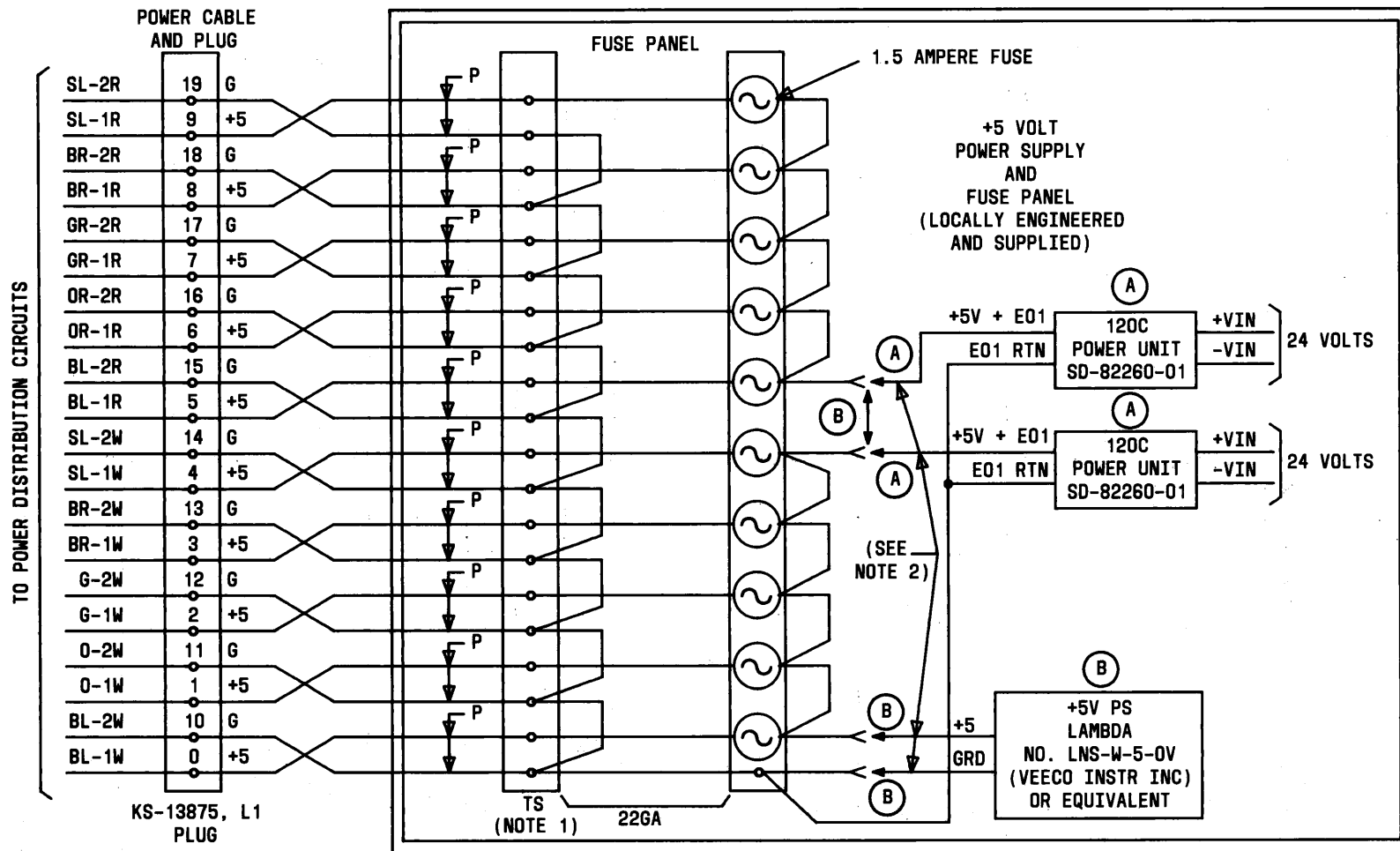

Fig. 23—Modification of Bulletin Holder for Rotary Card Dialer (MD)



NOTES:

1. THE TERMINAL STRIP CONSISTS OF A 66-TYPE CONNECTING BLOCK.
2. THE +5 VOLT POWER MUST BE SUPPLIED AND ENGINEERED LOCALLY. EITHER TWO 120C (A) POWER UNITS (5 AMPERES EACH) MAY BE USED TO DERIVE THE +5 VOLTS FROM -24 VOLTS DIRECT CURRENT OR A LAMBDA MODEL LNS-W-5-0V (B) (14 AMPERES) OR EQUIVALENT WHICH PROVIDES +5 VOLTS FROM 115-VOLTS ALTERNATING CURRENT IN BOTH CASES, THE VOLTAGE DROP ON THE +5 VOLT SWITCHBOARD FEEDER CABLE BETWEEN THE POWER SOURCE (+5V) AND THE YW1 CP SHALL NOT EXCEED 0.25 VOLTS. EACH YW1 CP CURRENT DRAIN IS 100 MA MAXIMUM AT +5 VOLTS, AN ADDITIONAL +5V FUSE ALARM LAMP MUST BE LOCALLY ENGINEERED AND PROVIDED.

Fig. 24—+5 Volt DC Power Supply Connections for Solid-State Secretarial Line Units

TABLE D
CONNECTIONS

FROM 357A PBX SE CR LINES		TO QUICK- CONNECT BLOCK 1		CROSS-CONNECT TO	
TERMINAL	COLOR	SECRETARIAL LINE		CABLE PAIR	NUMBER
1T 1R	W-BL BL-W	1	T R		
2T 2R	W-O O-W	2	T R		
3T 3R	W-G G-W	3	T R		
4T 4R	W-BR BR-W	4	T R		
5T 5R	W-S S-W	5	T R		
6T 6R	R-BL BL-R	6	T R		
7T 7R	R-O O-R	7	T R		
8T 8R	R-G G-R	8	T R		
9T 9R	R-BR BR-R	9	T R		
10T 10R	R-S S-R	10	T R		
11T 11R	BK-BL BL-BK	11	T R		
12T 12R	BK-O O-BK	12	T R		
13T 13R	BK-G G-BK	13	T R		
14T 14R	BK-BR BR-BK	14	T R		
15T 15R	BK-S S-BK	15	T R		
16T 16R	Y-BL BL-Y	16	T R		
17T 17R	Y-O O-Y	17	T R		
18T 18R	Y-G G-Y	18	T R		
19T 19R	Y-BR BR-Y	19	T R		
20T 20R	Y-S S-Y	20	T R		
21T 21R	V-BL BL-V	21	T R		
22T 22R	V-O O-V	22	T R		
23T 23R	V-G G-V	23	T R		
24T 24R	V-BR BR-V	24	T R		
25T 25R	V-S S-V	25	T R		

BLUE BANDS

TABLE D (Contd)
CONNECTIONS

FROM 557A PBX SE CR LINES		TO QUICK- CONNECT BLOCK 2		CROSS-CONNECT TO	
TERMINAL	COLOR	SECRETARIAL LINE		CABLE PAIR	NUMBER
26T	W-BL	26	T		
26R	BL-W		R		
27T	W-O	27	T		
27R	O-W		R		
28T	W-G	28	T		
28R	G-W		R		
29T	W-BR	29	T		
29R	BR-W		R		
30T	W-S	30	T		
30R	S-W		R		
31T	R-BL	31	T		
31R	BL-R		R		
32T	R-O	32	T		
32R	O-R		R		
33T	R-G	33	T		
33R	G-R		R		
34T	R-BR	34	T		
34R	BR-R		R		
35T	R-S	35	T		
35R	S-R		R		
36T	BK-BL	36	T		
36R	BL-BK		R		
37T	BK-O	37	T		
37R	O-BK		R		
38T	BK-G	38	T		
38R	G-BK		R		
39T	BK-BR	39	T		
39R	BR-BK		R		
40T	BK-S	40	T		
40R	S-BK		R		
41T	Y-BL	41	T		
41R	BL-Y		R		
42T	Y-O	42	T		
42R	O-Y		R		
43T	Y-G	43	T		
43R	G-Y		R		
44T	Y-BR	44	T		
44R	BR-Y		R		
45T	Y-S	45	T		
45R	S-Y		R		
46T	V-BL	46	T		
46R	BL-V		R		
47T	V-O	47	T		
47R	O-V		R		
48T	V-G	48	T		
48R	G-V		R		
49T	V-BR	49	T		
49R	BR-V		R		
50T	V-S	50	T		
50R	S-V		R		

ORANGE BINDER

TABLE D (Contd)
CONNECTIONS

FROM 557A PBX SE CR LINES		TO QUICK- CONNECT BLOCK 3		CROSS-CONNECT TO	
TERMINAL	COLOR	SECRETARIAL LINE		CABLE PAIR	NUMBER
51T 51R	W-BL BL-W	51	T R		
52T 52R	W-O O-W	52	T R		
53T 53R	W-G G-W	53	T R		
54T 54R	W-BR BR-W	54	T R		
55T 55R	W-S S-W	55	T R		
56T 56R	R-BL BL-R	56	T R		
57T 57R	R-O O-R	57	T R		
58T 58R	R-G G-R	58	T R		
59T 59R	R-BR BR-R	59	T R		
60T 60R	R-S S-R	60	T R		
61T 61R	BK-BL BL-BK	61	T R		
62T 62R	BK-O O-BK	62	T R		
63T 63R	BK-G G-BK	63	T R		
64T 64R	BK-BR BR-BK	64	T R		
65T 65R	BK-S S-BK	65	T R		
66T 66R	Y-BL BL-Y	66	T R		
67T 67R	Y-O O-Y	67	T R		
68T 68R	Y-G G-Y	68	T R		
69T 69R	Y-BR BR-Y	69	T R		
70T 70R	Y-S S-Y	70	T R		
71T 71R	V-BL BL-V	71	T R		
72T 72R	V-O O-V	72	T R		
73T 73R	V-G G-V	73	T R		
74T 74R	V-BR BR-V	74	T R		
75T 75R	V-S S-V	75	T R		

GREEN BINDER

TABLE D (Contd)
CONNECTIONS

FROM 557A PBX SE CR LINES		TO QUICK- CONNECT BLOCK 4		CROSS-CONNECT TO	
TERMINAL	COLOR	SECRETARIAL LINE		CABLE PAIR	NUMBER
76T	W-BL	76	T		
76R	BL-W		R		
77T	W-O	77	T		
77R	O-W		R		
78T	W-G	78	T		
78R	G-W		R		
79T	W-BR	79	T		
79R	BR-W		R		
80T	W-S	80	T		
80R	S-W		R		
81T	R-BL	81	T		
81R	BL-R		R		
82T	R-O	82	T		
82R	O-R		R		
83T	R-G	83	T		
83R	G-R		R		
84T	R-BR	84	T		
84R	BR-R		R		
85T	R-S	85	T		
85R	S-R		R		
86T	BK-BL	86	T		
86R	BL-BK		R		
87T	BK-O	87	T		
87R	O-BK		R		
88T	BK-G	88	T		
88R	G-BK		R		
89T	BK-BR	89	T		
89R	BR-BK		R		
90T	BK-S	90	T		
90R	S-BK		R		
91T	Y-BL	91	T		
91R	BL-Y		R		
92T	Y-O	92	T		
92R	O-Y		R		
93T	Y-G	93	T		
93R	G-Y		R		
94T	Y-BR	94	T		
94R	BR-Y		R		
95T	Y-S	95	T		
95R	S-Y		R		
96T	V-BL	96	T		
96R	BL-V		R		
97T	V-O	97	T		
97R	O-V		R		
98T	V-G	98	T		
98R	G-V		R		
99T	V-BR	99	T		
99R	BR-V		R		
100T	V-S	100	T		
100R	S-V		R		

BROWN BINDER

TABLE D (Contd)
CONNECTIONS

FROM 557A PBX TRUNK - STAL		TO QUICK- CONNECT BLOCK 5		CROSS-CONNECT TO	
TERMINAL	COLOR	CIRCUIT		CABLE PAIR	NUMBER
1T	W-BL	TRUNKS	1	T	
1R	BL-W		R		
2T	W-O		2	T	
2R	O-W		R		
3T	W-G		3	T	
3R	G-W		R		
4T	W-BR		4	T	
4R	BR-W		R		
5T	W-S		5	T	
5R	S-W		R		
6T	R-BL		6	T	
6R	BL-R		R		
7T	R-O		7	T	
7R	O-R		R		
8T	R-G		8	T	
8R	G-R		R		
9T	R-BR	9	T		
9R	BR-R	R			
10T	R-S	10	T		
10R	S-R	R			
11T	BK-BL	11	T		
11R	BL-BK	R			
12T	BK-O	12	T		
12R	O-BK	R			
13T	BK-G	13	T		
13R	G-BK	R			
14T	BK-BR	14	T		
14R	BR-BK	R			
15T	BK-S	15	T		
15R	S-BK	R			
16T	Y-BL	—	T		
16R	BL-Y	R			
1T	Y-O	STATION LINES	1	T	
1R	O-Y		R		
2T	Y-G		2	T	
2R	G-Y		R		
3T	Y-BR		3	T	
3R	BR-Y		R		
4T	Y-S		4	T	
4R	S-Y		R		
5T	V-BL		5	T	
5R	BL-V		R		
6T	V-O		6	T	
6R	O-V		R		
7T	V-G		7	T	
7R	G-V		R		
8T	V-BR		8	T	
8R	BR-V		R		
9T	V-S		9	T	
9R	S-V		R		

TABLE D (Contd)
CONNECTIONS

FROM 557A PBX STAL - GRD - BAT. - MISC		TO QUICK- CONNECT BLOCK 6		CROSS-CONNECT TO		
TERMINAL	COLOR	CIRCUIT		CABLE PAIR	NUMBER	
10T	W-BL	STATION LINES	10	T		
10R	BL-W			R		
11T	W-O		11	T		
11R	O-W			R		
12T	W-G		12	T		
12R	G-W			R		
13T	W-BR		13	T		
13R	BR-W			R		
14T	W-S		14	T		
14R	S-W			R		
15T	R-BL		15	T		
15R	BL-R			R		
16T	R-O		16	T		
16R	O-R			R		
GRD 1	R-G		GRD	GRD	GRD	
GRD 2	G-R				GRD	
GRD 3	R-BR	GRD	GRD	GRD		
GRD 16	BR-R			GRD		
BAT. (1) 1 *	R-S	BAT.	BAT.1			
BAT. (2) 2 *	S-R			BAT.2		
BAT. 14* (B)	BK-BL BL-BK	BAT.	B	BAT.		
MISC 14	BK-O	MISC	GEN	G		
MISC 15	O-BK			GEN	(±)	
SPARE	BK-G	SPARE				
	G-BK					
	BK-BR					
	BR-BK					
	BK-S					
	S-BK					
	Y-BL					
	BL-Y					
	Y-O					
	O-Y					
	Y-G					
	G-Y					
	Y-BR					
	BR-Y					
	Y-S					
	S-Y					
V-BL	SPARE					
BL-V						
V-O						
O-V						
V-G						
G-V						
V-BR						
BR-V						
V-S						
S-V						

* See paragraph 4.05.

