

9-TYPE STATION DIALS IDENTIFICATION AND MAINTENANCE

1. GENERAL

1.01 This section contains information for the 9-type dials.

1.02 This section is reissued to provide additional information on replacement of dial number plates.

2. PURPOSE

2.01 To provide a direct replacement for all 9-type dials.

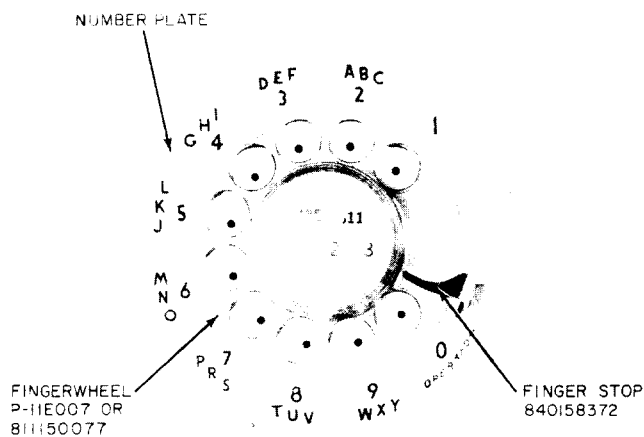
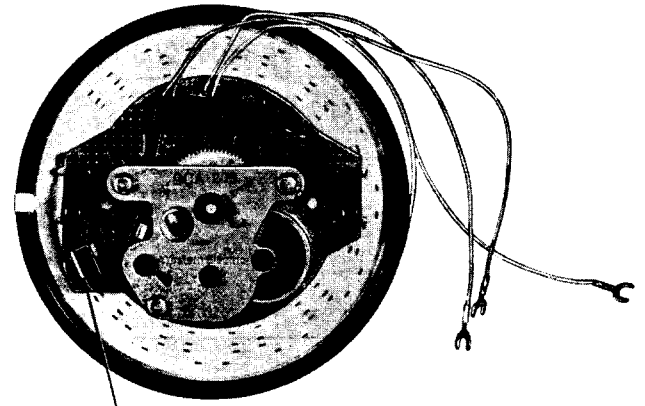

Fig. 1—9-Type Dial, Front View



FINGER STOP
DETENT ASSEMBLY

Fig. 2—9-Type Dial Rear View, Cover Removed

3. ORDERING GUIDE

3.01 Replaceable Components:

- 840470942 Plastic Cover
- 840158471 Clamp Plate
- Plate, Number (refer to Table A)
- 840158372 Finger Stop
- 811150077 (P-11E007) Fingerwheel.

NOTICE

Not for use or disclosure outside the
Bell System except under written agreement

TABLE A

UNIVERSAL NUMBER PLATE ORDERING GUIDE

COLOR	DIAL			
	9CA, 9HA	9KA	9LA	9MA, 9PA
Black	840677033	840679039	840680037	840677033
Ivory	840677504			
Moss Green	840677512			
Red	840677538			
Pastel Yellow	840677561			
White	840677587	840679583		
Lt. Beige	840677603			
Aqua Blue	840677629			
Transparent	840158968*			

* Available for 9CA only

4. APPLICATION

4.01 For application and replacement, see Table B.

◆ TABLE B ◆

DIAL	SCHEMATIC FIG.	PULSES PER SECOND	REPLACES	USE
9CA	4A	10	9C	General station sets. With colored sets or illuminated dial sets designed for 2-post mounting.
9CAM	4A	10		The 9CAM dial is to be used, when the number plate, fingerwheel, and fingerstops are to be added later in accordance with kit and/or modular telephone set procedures. *
9HA	4B	10	9H, 9L, 9LA, 9N	Has two pair of off-normal contacts designed for speakerphone systems. Also used on 532-, 533-, 535-, 536-type, and 568N telephone sets. 817A1 data auxiliary set. Data set 101A. 691A subscriber set. *
9HAM	4B	10		The 9HAM dial is to be used, when the number plate, fingerwheel, and fingerstop are to be added later in accordance with kit and/or modular telephone set procedures.
9KA	4B	10	9K	Modular telephone panels.
9MA	4A	10	9M	525-type telephone sets.
9PA	4C	10	9P	529B telephone set.

* Fig. 3.

5. MAINTENANCE

5.01 Parts of the dial shall not be broken or missing.

5.02 The finger stop may be slightly loose, but this is permissible and is not a trouble indication. With the dial in its unoperated position, the finger stop shall not overlap the "0" hole by more than 3/64 inch.

5.03 The dial shall operate smoothly without slipping or skipping.

(a) Check by operating dial several times.

- Replace dial if it fails in this requirement or is suspected of giving wrong numbers.

- Replace dial if improper dial speed or gear mesh is suspected.

5.04 Do not lubricate any part of the dial.

5.05 Exterior parts of the dial should be wiped with a dry KS-2423 cloth.

5.06 Clean number plate with a damp KS-2423 cloth.

- If number plate cannot be cleaned or is marred or chipped, replace (paragraph 5.13).

PLASTIC FINGERWHEEL

5.07 To remove fingerwheel.

- (1) Rotate fingerwheel as far as possible in clockwise direction.

(2) Insert KS-21107 releaser or equivalent into small hole located in edge of raised center of fingerwheel (Fig. 5) and push down to disengage the fingerwheel clamp spring.

(3) When clamp spring releases, remove fingerwheel, by turning fingerwheel slightly further in clockwise direction and then lifting fingerwheel.

5.08 To replace fingerwheel.

(1) Place fingerwheel over clamp with "0" hole directly over digit 9, making sure fingerwheel depressions are properly positioned on prongs of clamp plate.

(2) Rotate fingerwheel in counterclockwise direction until clamp springs snaps into notch on underside of fingerwheel (Fig. 6).

FINGER STOP ON CURRENT DIALS

5.09 To remove finger stop.

(1) Insert KS-21107 releaser or equivalent (Fig. 7A) and push in on plastic detent.

(2) Remove finger stop (Fig. 7B).

5.10 To replace finger stop.

(1) Insert finger stop into slot in number plate and push down until square hole in finger stop engages plastic detent assembly and snaps into place.

FINGER STOP ON MD DIALS

5.11 To remove finger stop on (MD) 9-type dials.

(1) Loosen finger stop mounting screw located under the number plate.

(2) Remove the finger stop by slipping it through the slot in the number plate.

5.12 To replace finger stop.

(1) Pass the end of the finger stop with the elongated mounting slot through the slot in the number plate so that the slot goes around the loosened mounting screw to its full depth.

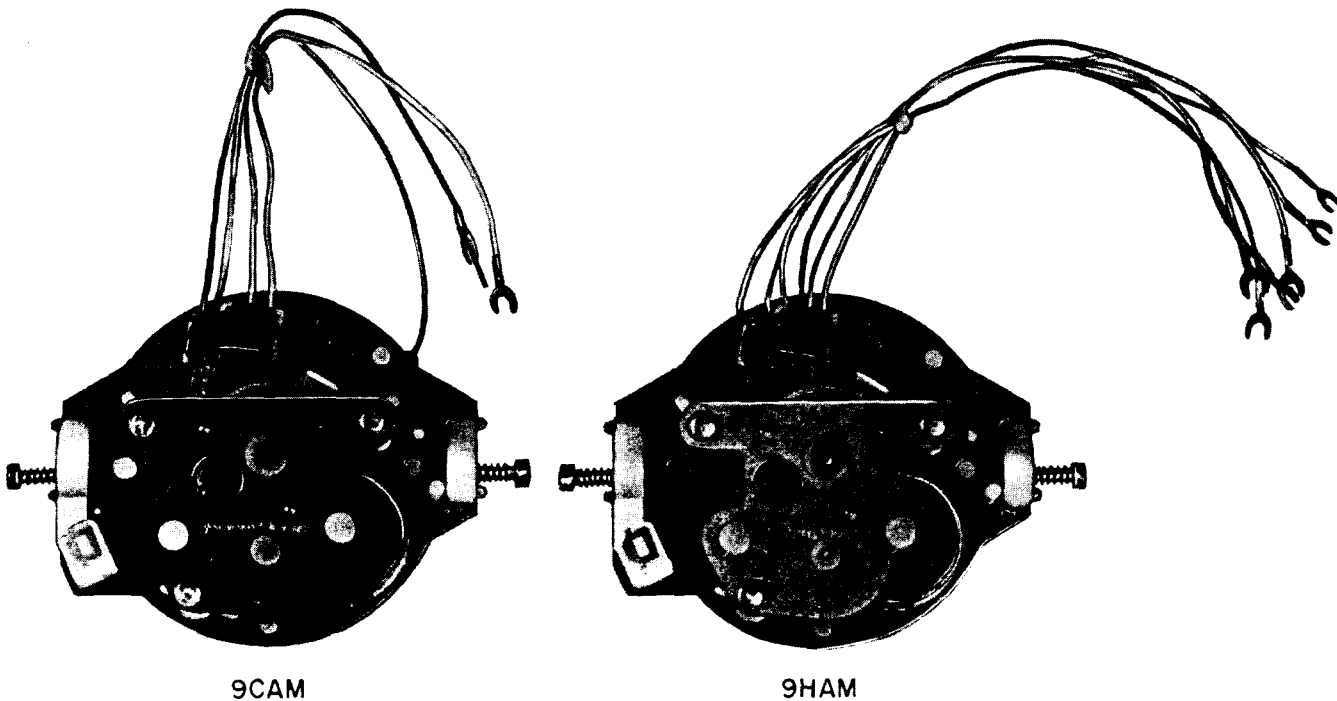

Fig. 3—9CAM and 9HAM Dials, Rear View

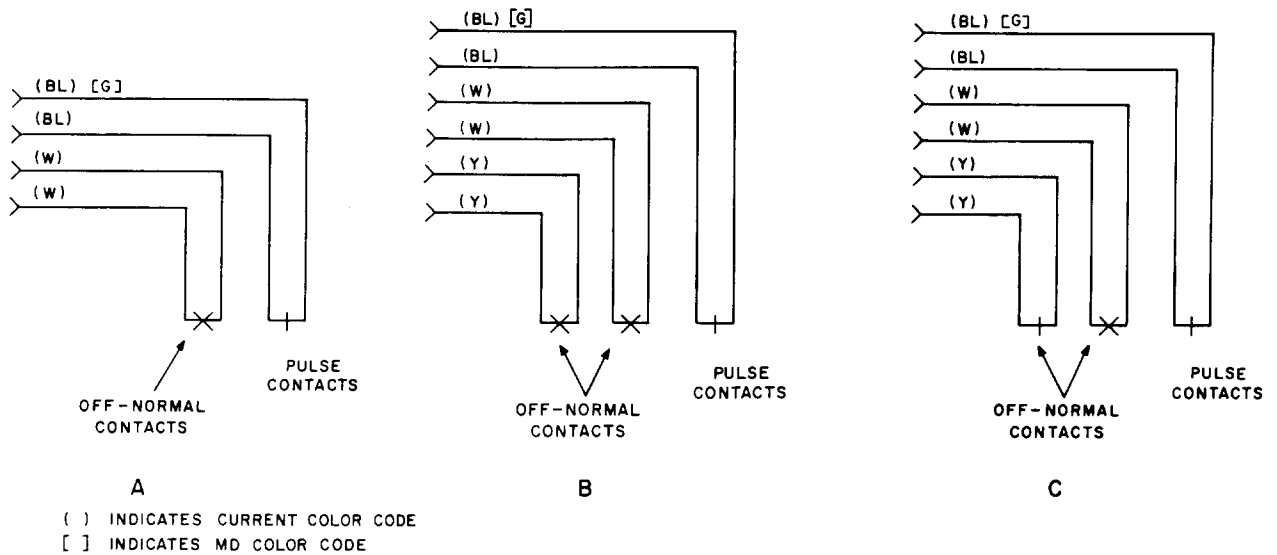

Fig. 4—Dial Contact Schematics

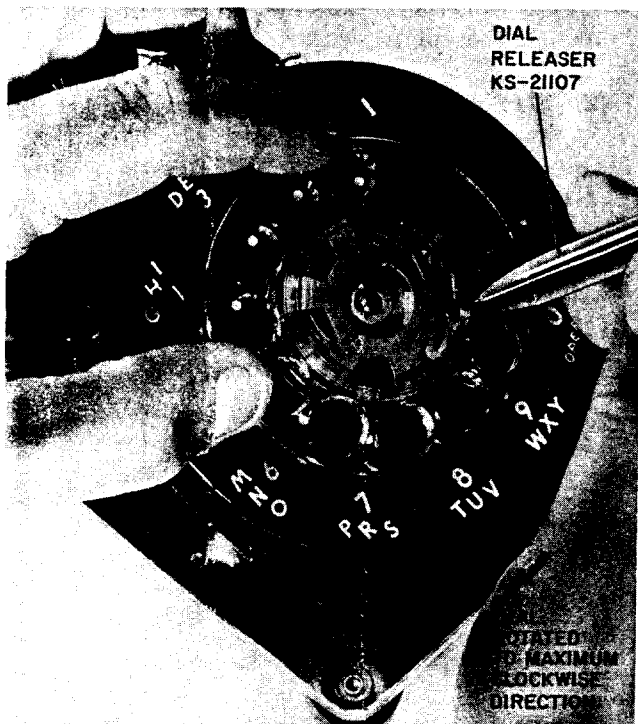

Fig. 5—Removing Plastic Fingerwheel

(2) Tighten the mounting screw. With the dial in its unoperated position, the finger stop shall not overlap the "0" hole by more than 3/64-inch.

NUMBER PLATE ON CURRENT DIALS

5.13 To remove number plate.

- (1) Remove fingerwheel (paragraph 5.07).
- (2) Remove finger stop (paragraph 5.09).
- (3) Rotate number plate clockwise approximately 1/4-inch (Fig. 7C) until it is free of clamp plate assembly.
- (4) Lift off number plate.

5.14 To install new number plate, place number plate finger stop slot 1/4-inch clockwise of alignment with dial assembly finger stop slot. Rotate number plate counter clockwise to align finger stop and to lock plate on.

NUMBER PLATE ON MD DIALS

5.15 It may become necessary to remove number plates on (MD) 9-type dials and replace with new universal type number plates (Table A). To remove number plate:

- (1) Remove fingerwheel (paragraph 5.07).
- (2) Remove finger stop (paragraph 5.11).

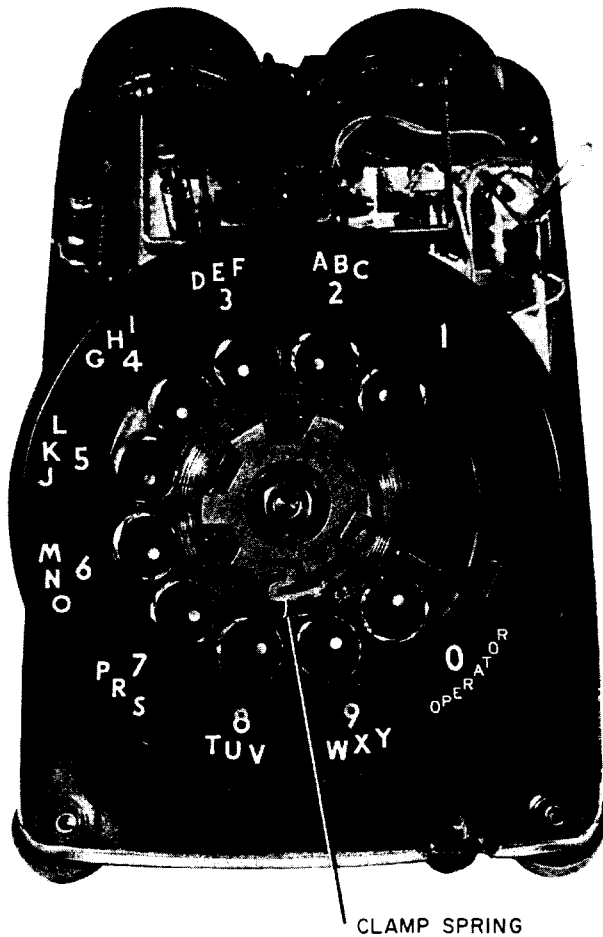

Fig. 6—▶Replacing Plastic Fingerwheel◀

Danger: For safety, when removing lock ring with ▶long-nose pliers◀, exercise caution to prevent ▶pliers◀ from slipping.

- (3) Insert tip of ▶long-nose pliers◀ into one of the three slots on the lockring (Fig. 8).
- (4) Rotate lockring as shown in Fig. 9 until it is free.
- (5) Raise lockring until it is just under the clamp plate and slide toward the numeral 4 until the upper end of the ring can be lifted over the clamp plate (Fig. 10). Slide ring toward numeral 9 to remove. Retain lockring for reuse.
- (6) Lift off old number plate.

5.16 ▶To install new number plate proceed as follows.

- (1) Place number plate on dial assembly aligning the finger stop slots in both the dial assembly and number plate.
- (2) Place lockring over clamp plate and set into insert in number plate.
- (3) Turn lockring clockwise engaging lockring tabs in dial assembly slots.
- (4) Using long-nose pliers (Fig. 11), fully engage lockring in locking tabs. ▶

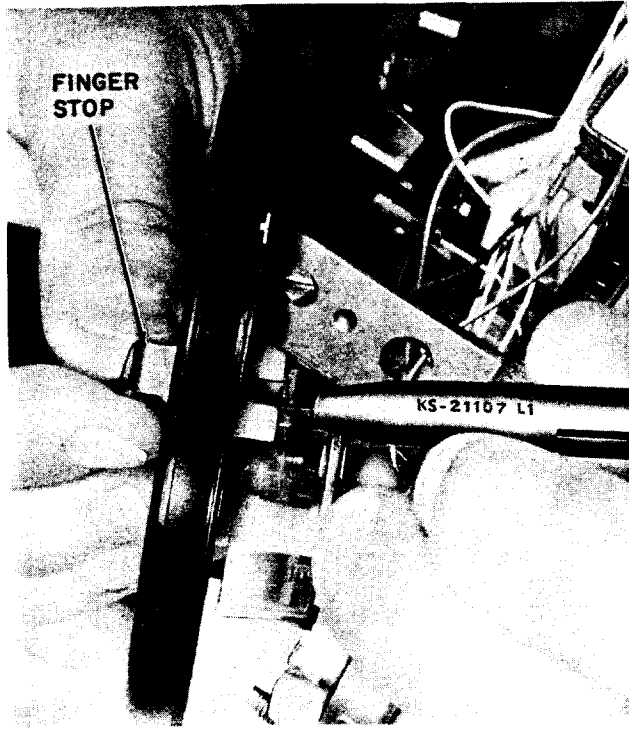

A

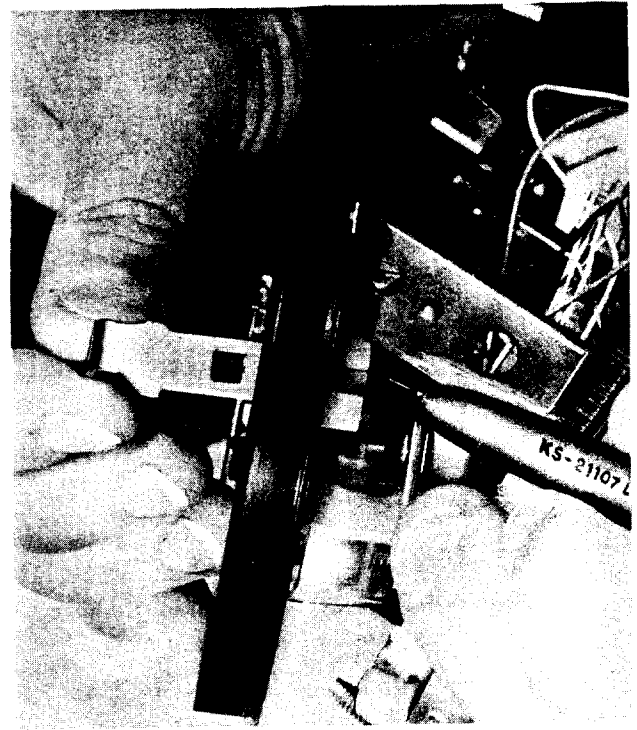

B

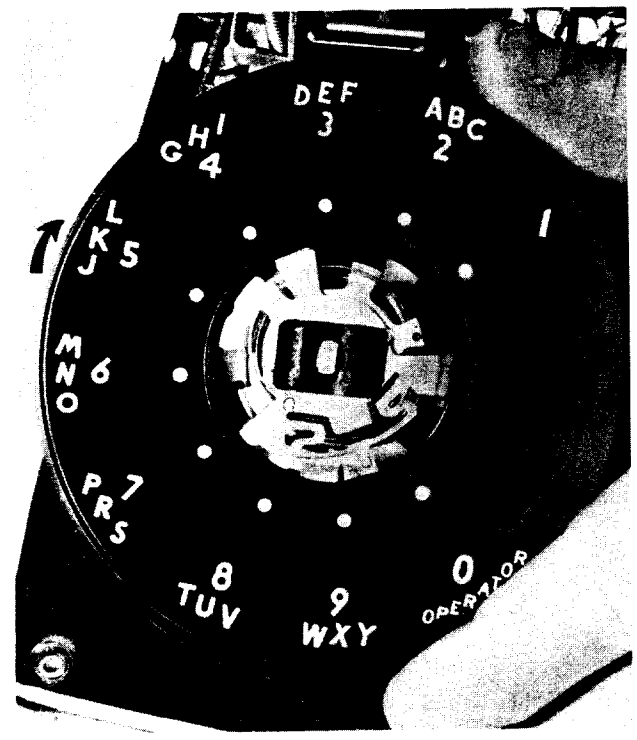

C

Fig. 7—♦Removal of Finger Stop and Number Plate♦

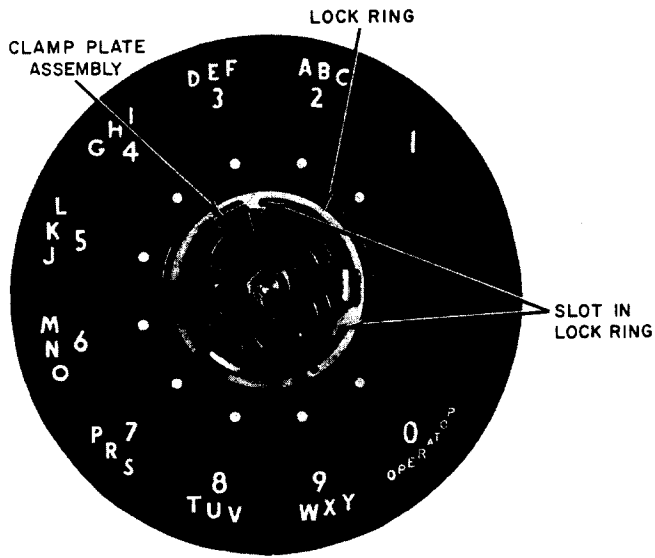

Fig. 8—Fingerwheel and Finger Stop Removed to Show Lockring

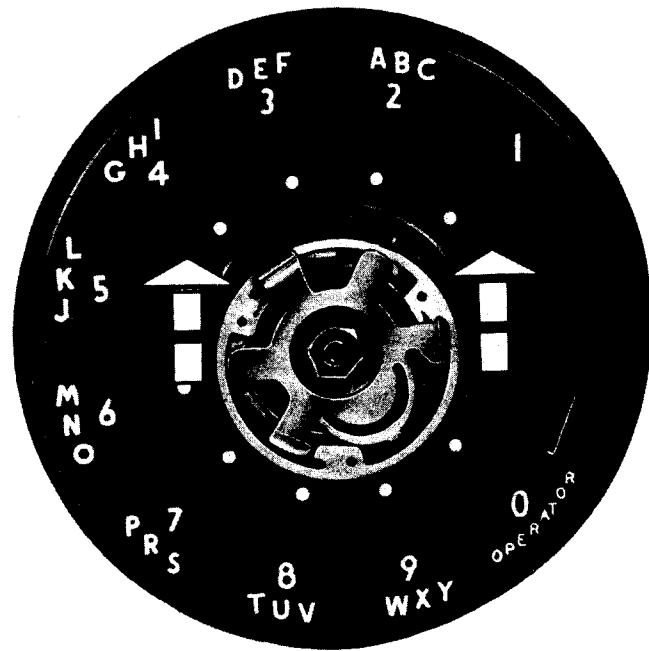

Fig. 10—Lockring in Extreme Forward Position for Removal



Fig. 9—Lockring Removal

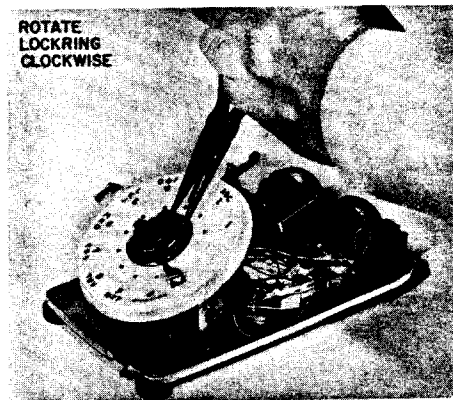

Fig. 11—Lockring Installation