

## RINGER—E1-TYPE

### 1. GENERAL

1.01 This section contains identification, installation, connections, and maintenance information on the E1-type ringer.

1.02 This section is reissued to:

- Add 1049A mounting plate
- Add 290A adapter

1.03 The E1-type ringer (Fig. 1) may be used on the following services:

- Individual lines
- 2-party flat and message rate
- 4-party semiselective
- Nonselective party line
- Divided code ringing
- Regular PBX station.

1.04 When controlled by a 531C or 687B subscriber set, the E1-type ringer may be used on the following services:

- 4-party full selective
- 8-party semiselective.

1.05 See appropriate section for subscriber set connections.

1.06 Obtain tip party identification, when required, through the ringer associated with each station. Refer to section covering connections for particular type of telephone set used.

### 2. IDENTIFICATION

2.01 The E1C and E1D (nonmodular) ringer (Fig. 2 and 3) consists of a 7- or 10-terminal connecting block and a single-gong ringing mechanism in series with an 0.40  $\mu$ f capacitor.

2.02 The E1CM (modular) ringer (Fig. 7) is identical to the E1C except it has a 652A6 (**Phone**) jack and a 623P4 (**Line**) jack connected to an eight terminal connecting block.

2.03 The E1-type ringer is equipped with a volume control lever (Fig. 2). Volume is adjustable from OFF to LOUD. To adjust ringer to off position, refer to 3.06.



***Be sure to acquaint customer with location and use of ringer volume control lever.***

2.04 The ringing mechanism, capacitor, and connecting block are mounted on a gray metal base enclosed with a light olive gray or ivory plastic cover. Refer to Table A for color ordering information.

2.05 The E1A, E1B, E1C, and E1D ringers are rated MD and are replaced by the E1CM ringer. The E1C/CM and E1D ringers have a gong resonator to improve the audible characteristics.

2.06 The E1B (MD) and E1D (MD) ringers are used with the 2A farm interphone as an auxiliary ringer, connecting block, and remote signal control.

### 3. INSTALLATION

3.01 The E1-type ringer may be mounted to a 63-type, KS-19407L1 (MD), or KS-20502L2 bracket, or on an electrical outlet box using a 146B adapter. All necessary screws are provided with the adapter.

### NOTICE

Not for use or disclosure outside the  
Bell System except under written agreement

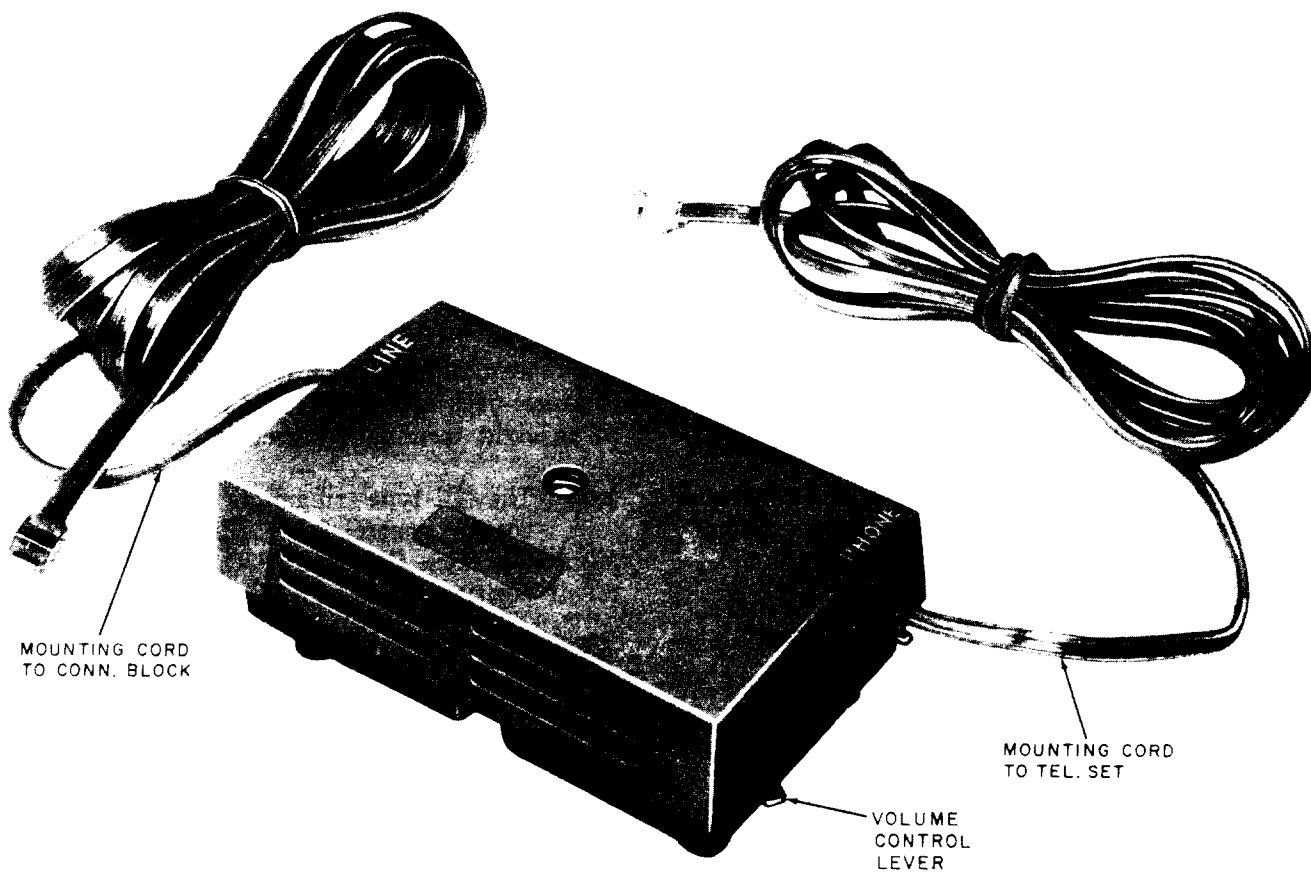

Fig. 1—E1CM Ringer, External View

◆ TABLE A ◆

## COLOR ORDERING GUIDE (COVER)

E1-TYPE	LIGHT OLIVE GRAY	IVORY
Nonmodular	818144495 (P-81D449)	818144503 (P-81D450)
Modular	841026552	841026560

**3.02** Mounting holes in the ringer are fitted with rubber grommets. Unless using a 146B adapter, use screws of sufficient length to hold ringer to mounting surface securely.

**3.03** For nonmodular type ringers, the inside wire can enter the ringer from the bottom or either end (Fig. 2 and 3). The mounting cord from

the telephone set may be brought in from either end of ringer. The E1-type ringers have a stayhook holder on the left side which can be moved to the right side, if desired. Secure telephone set cord to ringer as shown in Fig. 4.

**3.04** The modular styled ringer (E1CM) is equipped with a 623P4 (*Line*) jack and a 652A6 (*Phone*) jack. The D4BU mounting cords may be used to provide connections between the ringer and jack equipped connecting block, and between the ringer and telephone set.

**3.05** ◆The E1CM ringer may be made portable by adding a 290A adapter to the ringer and the placement of a 1049A mounting plate at desired locations as follows.

**Note:** The cover must be removed ◆to secure ringer to 290A adapter.◆

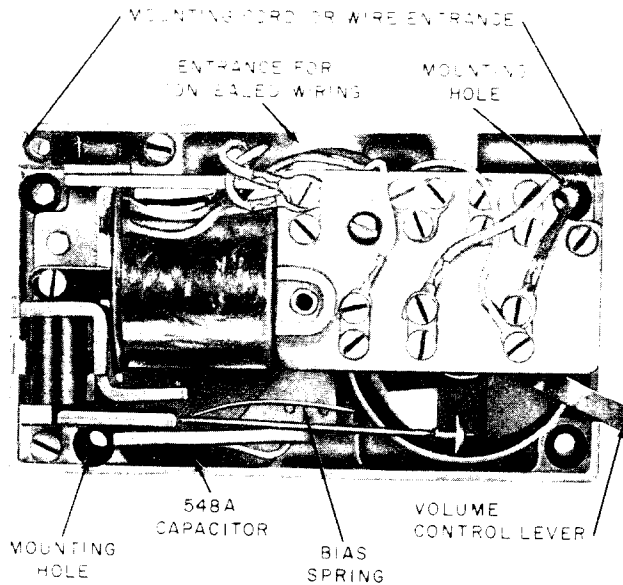

Fig. 2—E1C Ringer, Internal View

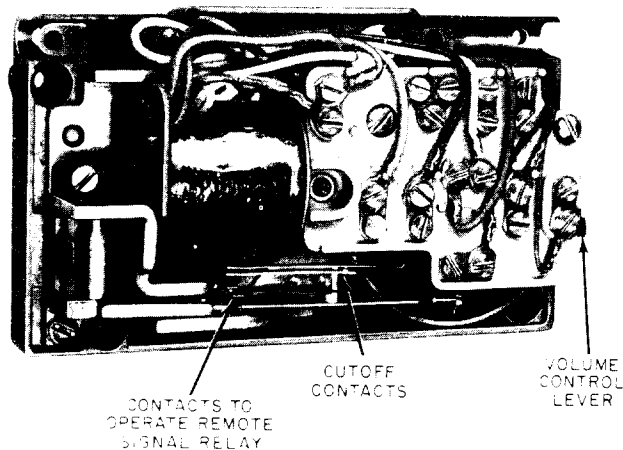

Fig. 3—E1D Ringer, Internal View

(a) Secure the 1049A mounting plate to mounting surface using appropriate fasteners for the type surface involved.

(b) Remove the rubber grommets from base of E1CM ringer and secure the 290A adapter to the ringer using the screws provided with the adapter.

**Note:** Two screws are placed through the adapter and into the ringer. One screw is

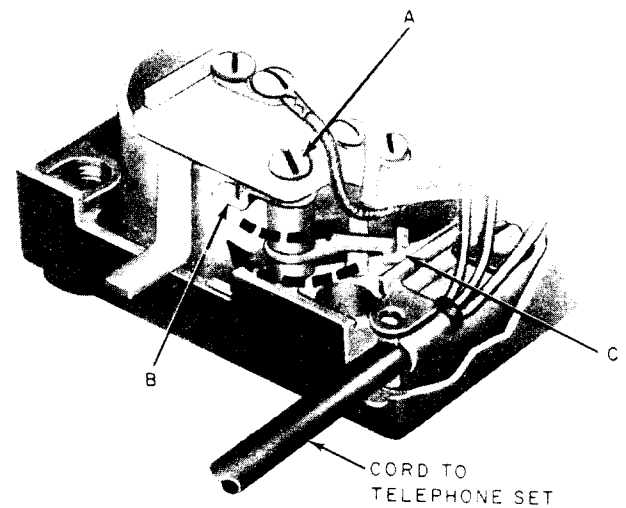

Fig. 4—E1C Ringer, End View

placed through the ringer and into the adapter (Fig. 6).

(c) Mount the ringer by placing the slotted holes in the 290A adapter onto the studs of the mounting plate and push down to secure.♦

### 3.06 To silence ringer.

(a) E1C ringer (Fig. 4).

(1) Loosen screw A.

(2) Move stop B to right.

(3) Move volume control to off.

(4) Move latch C to the left so that it falls in place over the volume control lever. This will lock ringer in off position.

(5) Tighten screw A.

(b) E1CM ringer (Fig. 5).

(1) Loosen screw A.

(2) Move stop B to position shown.

**Note:** Stop B should be under terminal board to prevent interference with jack, but not touching terminal 4.

(3) Move volume control to off.

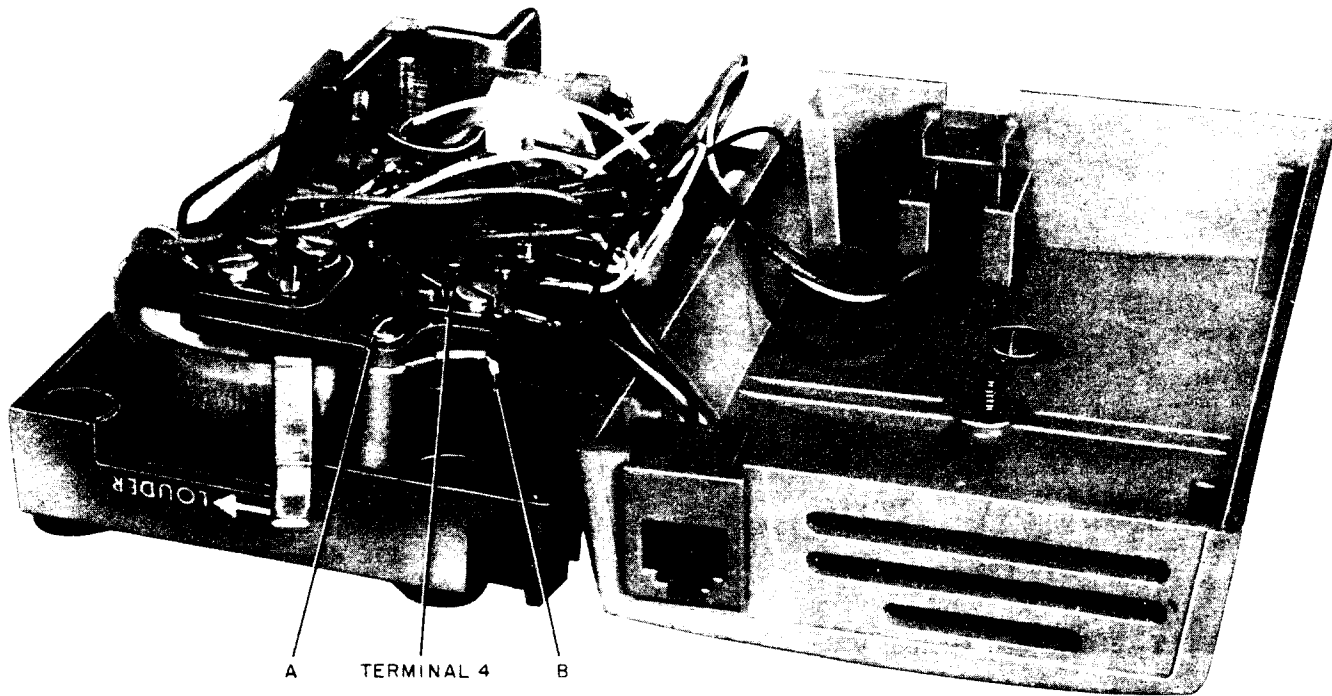

Fig. 5—E1CM Ringer, End View

(4) Tighten screw A.

#### 4. CONNECTIONS

**4.01** Connections for nonmodular type ringers are shown in Fig. 8 and modular type ringer in Fig. 9.

**4.02** The E1D ringer is equipped with two sets of contacts (Fig. 3). One set, controlled by the clapper, operates a remote signal relay; the other set, operated by the volume control cam, cuts off remote signals. For connections, refer to section on farm interphone.

#### 5. BIAS SPRING POSITION

**5.01** The ringer is shipped with bias spring in the high (outside) notch. Table B indicates proper bias spring position for various classes of service.



***Do not bend bias spring. Correct bias spring tension has been set at the factory.***

**5.02** Obtain a ringing test, after completing installation. Check for bell taps while dialing.

**5.03** If bell does tap with bias spring in low notch, move bias spring to high notch. Repeat ringing test.

#### 6. MAINTENANCE

**6.01** If ringer fails to operate properly, check for the following:

- (1) Airgap is clear of dirt or foreign material. Clean if necessary.
- (2) All connections are tight and correct.
- (3) Leads do not interfere with ringer operation.
- (4) The 548A capacitor is not open or shorted. Replace if defective.

**6.02** Replace ringer if it still fails to operate properly.

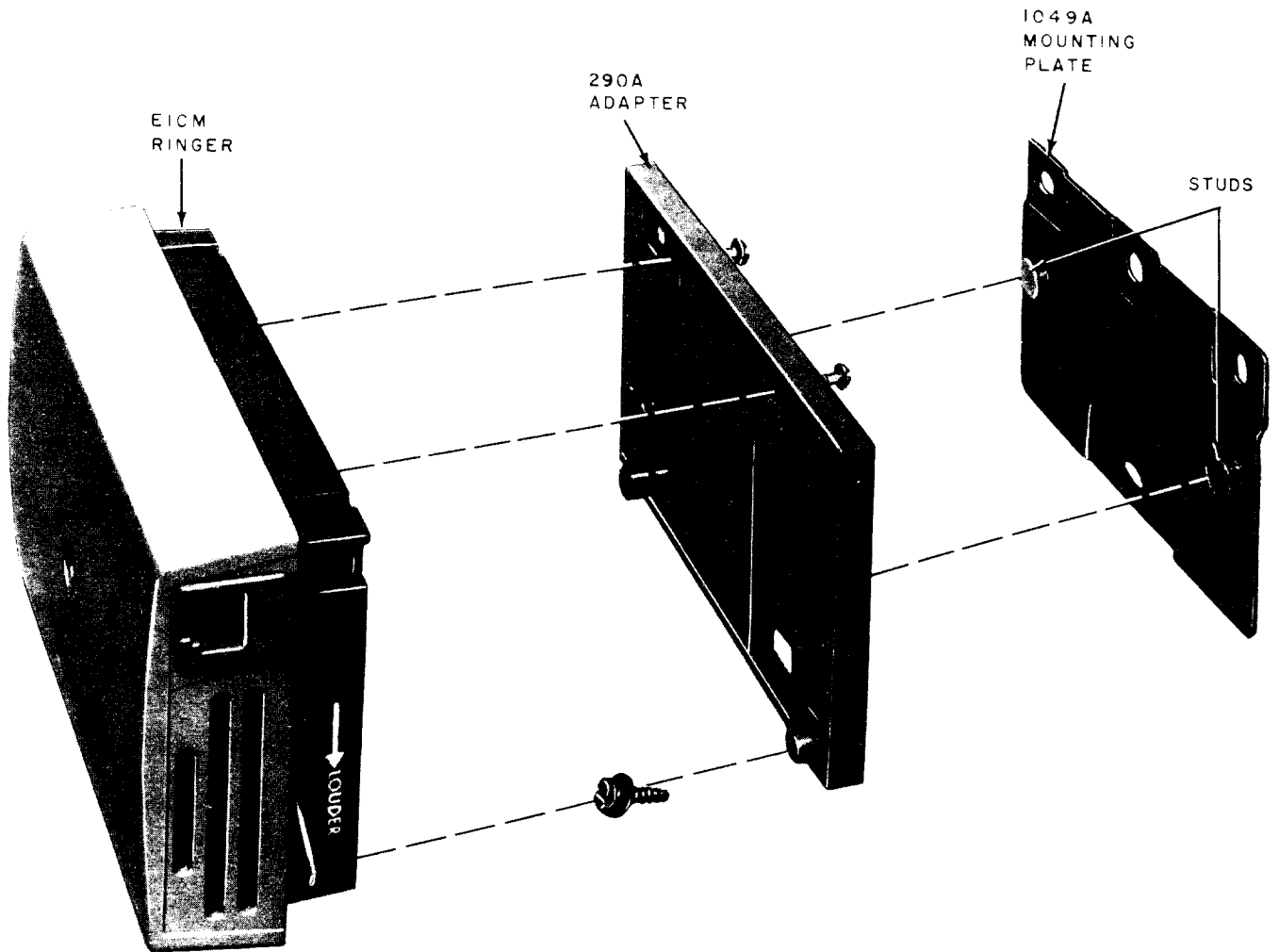

Fig. 6—E1CM Ringer, 290A Adapter, and 1049A Mounting Plate

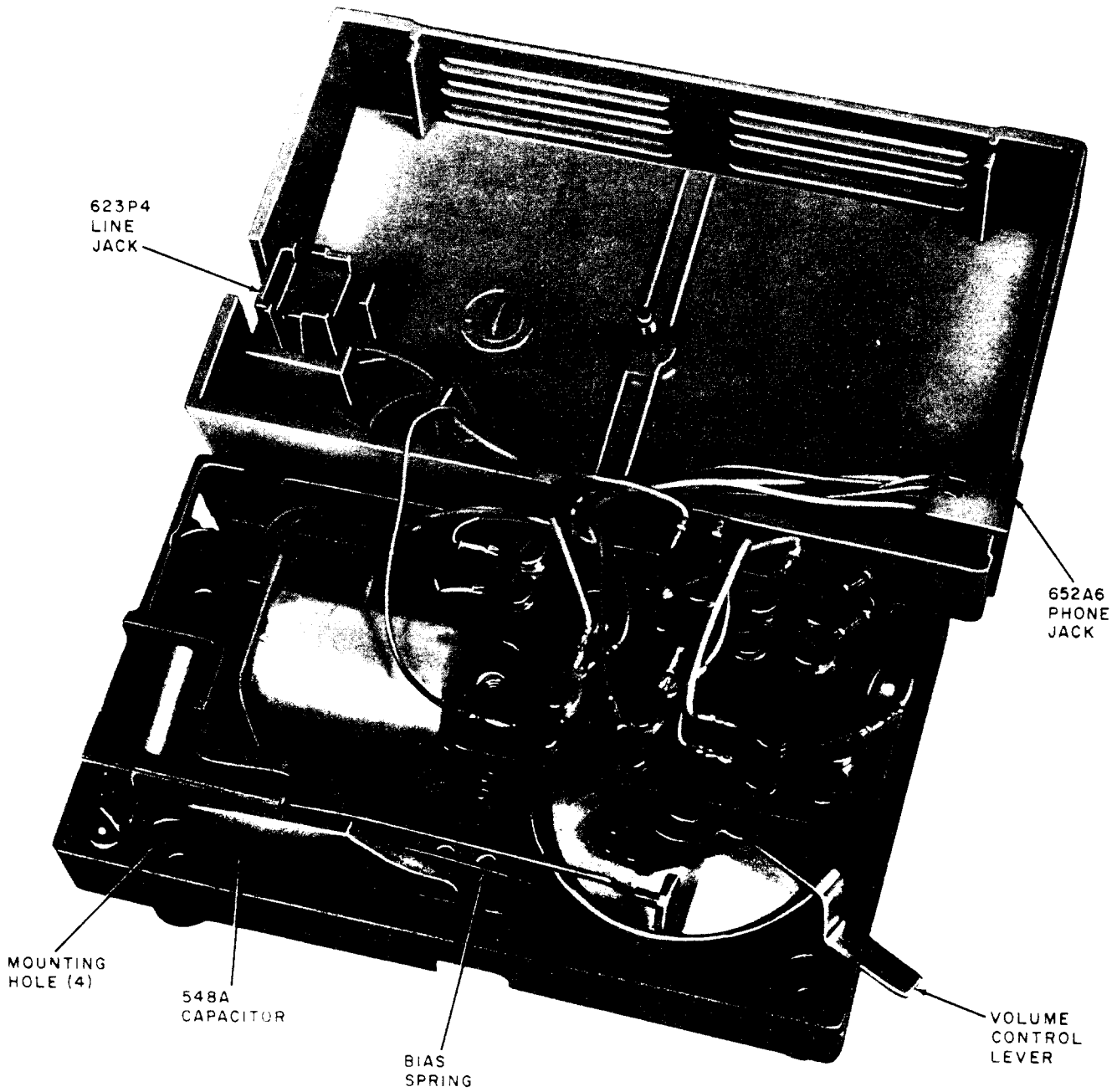

Fig. 7—E1CM Ringer, Interval View

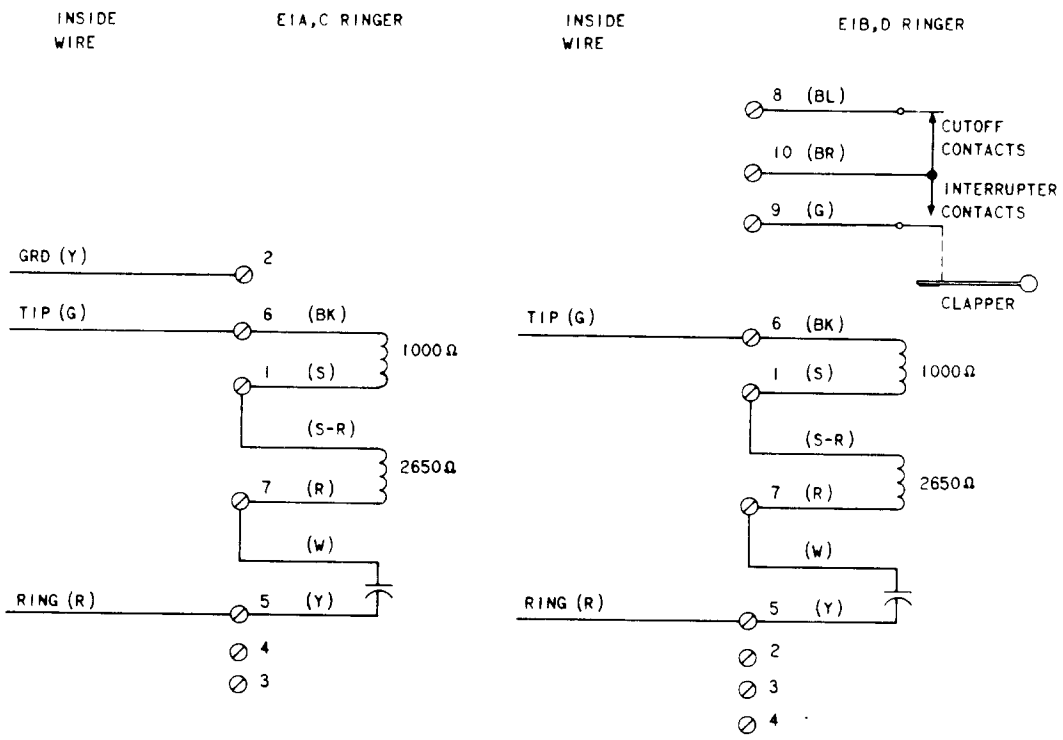

Fig. 8—E1-Type Ringer, Connections (Nonmodular)

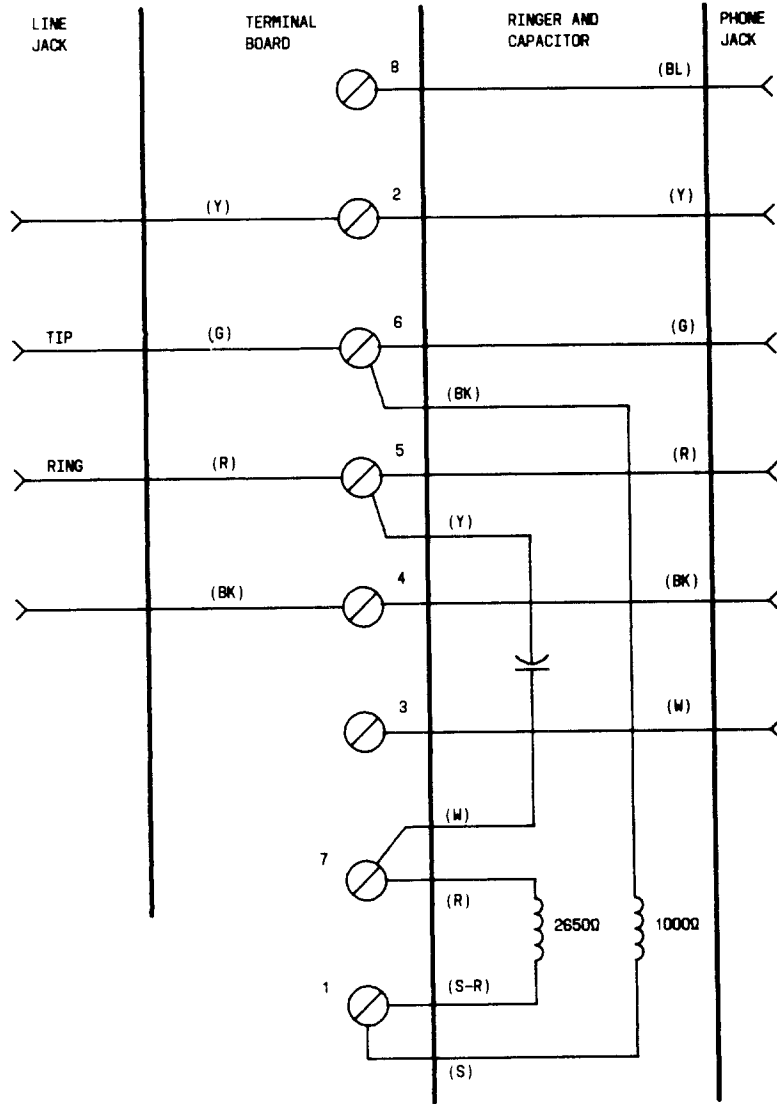

Fig. 9—E1CM Ringer, Connections (Modular)



◆ TABLE B ◆

## BIAS SPRING POSITION

CLASS OF SERVICE		BIAS SPRING NOTCH	REMARKS
Bridged Ringing Service	Individual Line and PBX Stations	High	If three or more ringers are bridged across line and operation is not satisfactory, place bias spring in low notch on all ringers. If condition still exists, replace ringer.
	Nonselective Party Lines	Low	
Grounded Ringing Service	2-party Flat and Message Rate	High	
	4-party Semiselective	High	If five ringers are connected between same side of line and ground, and operation is not satisfactory, place bias spring in low notch on all ringers on that side of line. If condition still exists, replace ringer.
	4-party Full Selective 8-party Semiselective Divided Code	Low	If ringer buzzes on short-loop installations when the party of opposite polarity on same side of line is being called, place bias spring in high-tension notch. If ringer still buzzes or fails to ring, replace ringer.