

AL1 TELEPHONE BASE

IDENTIFICATION, INSTALLATION, CONNECTIONS, AND MAINTENANCE

LIBRARY
FILE COPY

1. GENERAL

- 1.01** This section contains information on the AL1 telephone base (Elevator Telephone Set).
- 1.02** The reason for reissuing this section is to change Fig. 6. Revision arrows are used to emphasize the more significant changes.
- 1.03** The AL1 telephone base replaces the 322B and 758A telephone sets which are rated MD.

2. IDENTIFICATION

- 2.01** The AL1 (Fig. 1) is a flush-mounted, wall type telephone base designed to be used in elevators. It may also be used in corridors and in building entrances. The AL1 telephone base is available in black (-03) only.
- 2.02** The AL1 telephone base is intended for use with a 220- or 2220-type hand telephone set.
- 2.03** The base consists primarily of a faceplate assembly (Fig. 2), a mounting plate assembly (Fig. 3), and a D-kit of parts. These components are intended to mount in an outlet box installed by the customer or in an existing opening which is suitable for housing the base.

Ordering Guide

2.04 Order as follows:

- (a) Base, Telephone, AL1-03; includes the following:
- 840399455 Faceplate Assembly
 - 840399463 Mounting Plate Assembly
 - 812558039 (P-25E803) Card Retainer
 - 802056515 (P-205651) Mounting Screws (2).
- 2.05** Associated apparatus or equipment (ordered separately) is as follows:

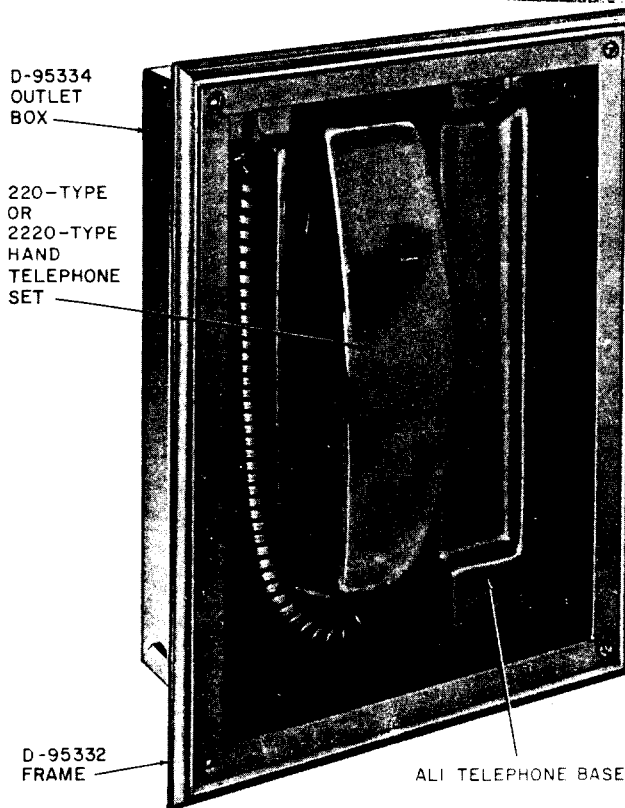

Fig. 1—AL1 Telephone Base and Hand Telephone Set Installed in Outlet Box

- Set, Telephone, Hand, 220C-03, 220AL-03, 220AM-03, 2220C-03, or 2220BM-03

Note: The 220AM and 2220BM hand telephone sets must be equipped with a 227D adapter.

- Box, Outlet, D-95334
- Frame, D-95332
- Kit of Parts, D-180793 (includes mounting

NOTICE

Not for use or disclosure outside the
Bell System except under written agreement

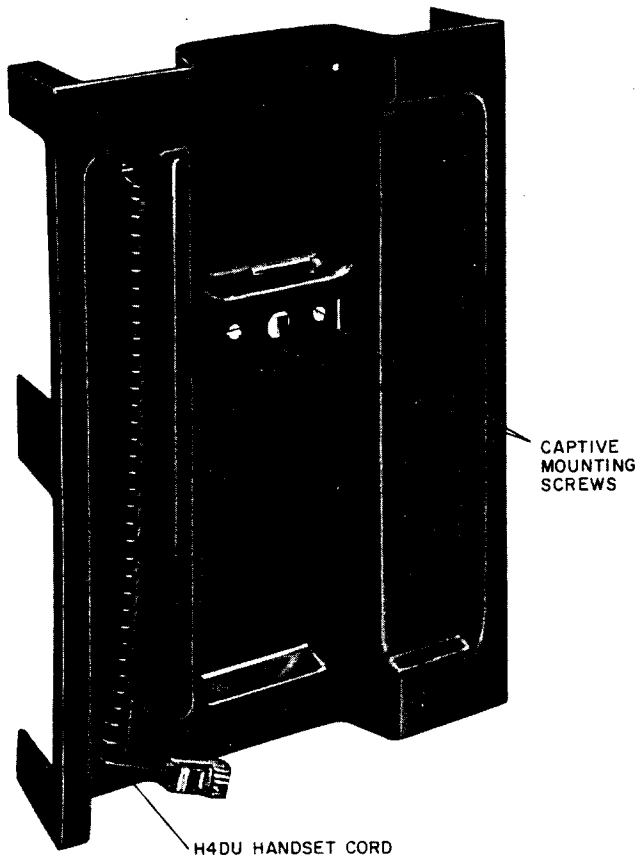

Fig. 2—840399455 Faceplate Assembly

bracket, screw, terminal board, and jack).

2.06 Replaceable Components: Refer to ordering guide and associated apparatus or ordered separately equipment. The following are also replaceable:

- Cord, Handset, H4DU-03
- Cord, M4AR-29
- Buzzer, 9A.

3. INSTALLATION



It is not permissible for a telephone company employee to enter any elevator shaft.

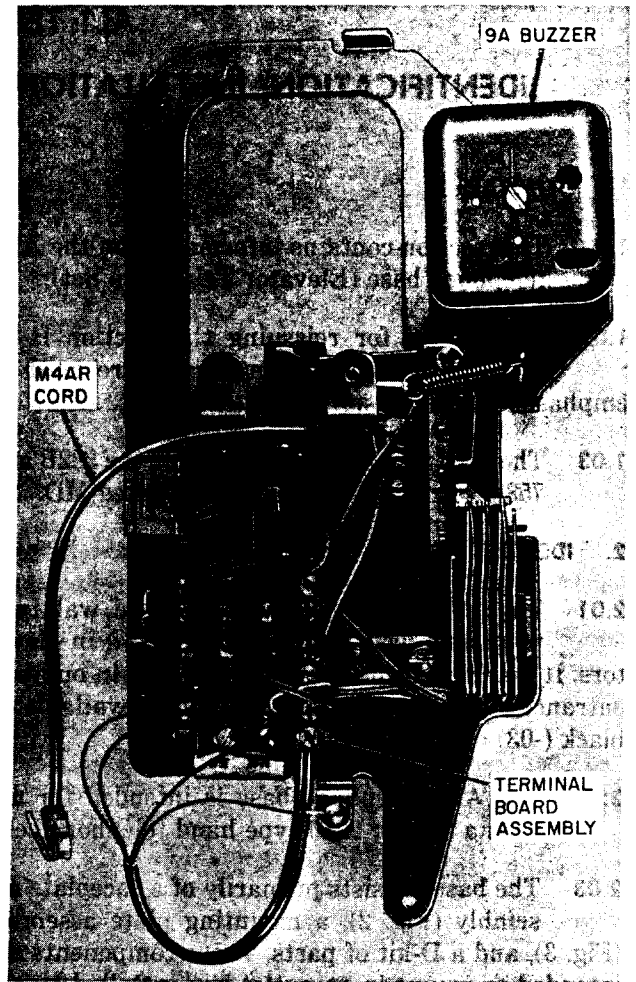

Fig. 3—840399463 Mounting Plate Assembly

3.01 The outlet box, frame, and kit of parts must be ordered separately and given to the customer for installation.

A. Wiring

3.02 Elevator cable conductors should be provided, installed, and maintained by the customer.

3.03 These conductors may be in a separate trailer cable or be spare conductors in elevator signaling and control cables.

3.04 Mount terminals or connecting blocks at a location outside the elevator shaft where cable conductors and telephone station wires terminate.

B. Outlet Boxes



If the customer supplies the outlet box, the mounting hole information should be provided (Fig. 6).

Caution: The customer should be cautioned about maintaining the necessary clearances between the elevator and shaft during the installation of the outlet box.

3.05 Outlet boxes (Fig. 4 and 5) furnished by the customer or telephone company should be installed by the customer.

3.06 It is recommended that generally the standard outlet box (Fig. 4 or 5) be mounted in a recess 10-1/4 inches high, 7-1/4 inches wide, 3 inches deep, and 53 inches from floor as illustrated in Fig. 5 or as specified by the customer.

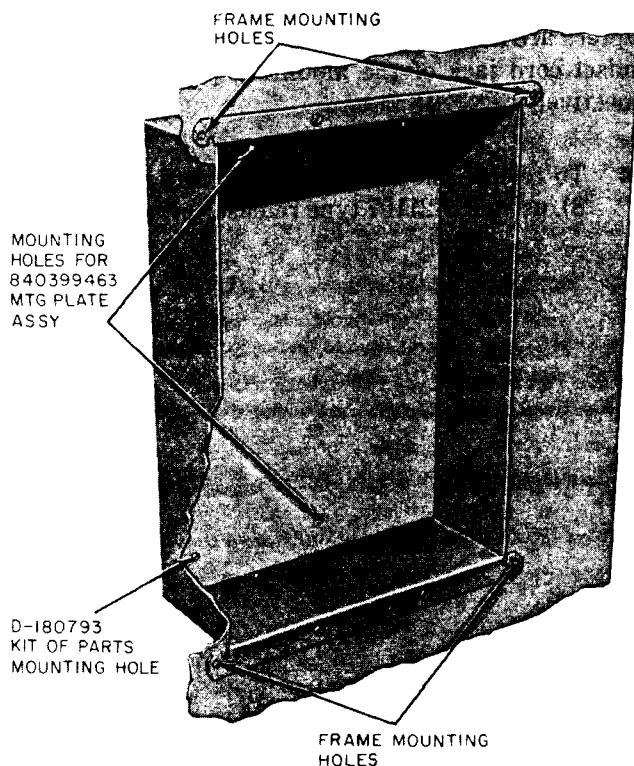

Fig. 4—D-95334 Outlet Box

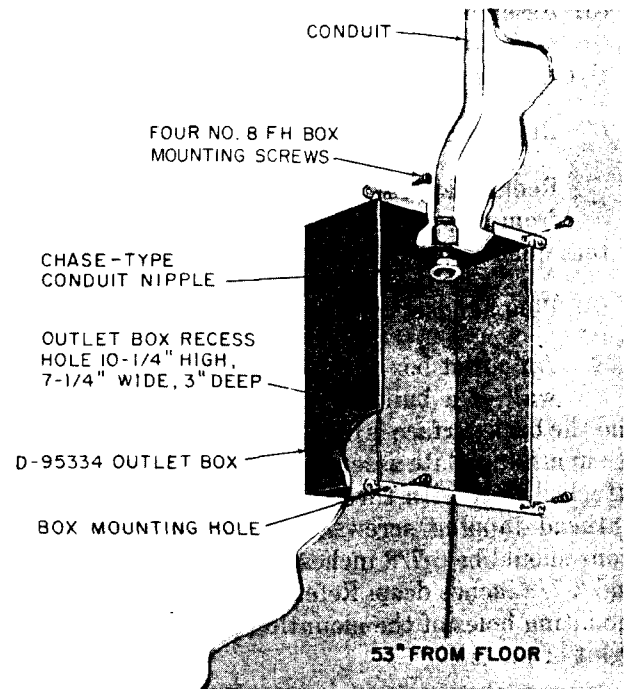

Fig. 5—Mounting of Outlet Box

3.07 When an AL1 telephone base is to be mounted in a door-equipped box, the minimum inside dimensions should be 7-1/4 inches wide, 10-1/4 inches high, and 3-1/2 inches deep.

3.08 Install the AL1 telephone base as follows.

- (1) Mount the mounting plate assembly in the outlet box using two round head machine screws 802056515 (P-205651) furnished with the box (Fig. 4 and 5).
- (2) Install the D-180793 Kit of Parts in lower left hand corner mounting hole of the outlet box as shown in Fig. 7. Mount the kit of parts with the round head machine screw 802056515 (P-205651) which is provided.
- (3) Make station wire connections to the kit of parts terminal board. Refer to Part 4.
- (4) Plug the M4AR cord into 623P4 jack (Fig. 7) and handset cord into handset cord jack located on mounting plate assembly.

SECTION 502-330-100

- (5) Assemble the faceplate assembly to the mounting plate assembly using the two captive screws located in the faceplate (Fig. 2).
- (6) Replace 812558039 (P-25E803) card retainer.
- (7) Remove approximately 0.1 inch of locking tab from plug of handset cord. This procedure deters unauthorized hand telephone set removal.
- (8) Plug handset cord into the hand telephone set.

3.09 An outlet box is not required where recess in wall of a building meets the minimum size, and the back surface is of wood 3/4-inch thick so that the mounting plate assembly and kit of parts may be attached to it with three No. 8, 1-inch pan head or flathead tapping screws. Inside minimum dimensions should be 6-7/8 inches wide, 9-7/8 inches high, and 2-7/8 inches deep. Refer to Fig. 6 for location of mounting holes of the mounting plate assembly, and D-kit of parts.

C. Frames

- 3.10** Use a standard metal frame or wood molding to cover edges of recess.
- 3.11** The frame is shown in Fig. 1.
- 3.12** The frame attaches to the outlet box with four 9/32-inch by 6-32 oval head brass machine screws that are furnished with the frame (Fig. 1).

4. CONNECTIONS

- 4.01** For wiring and connections of the AL1 telephone base, refer to Fig. 9.
- 4.02** Station wiring connects directly to the terminal board on the kit of parts.

5. MAINTENANCE

- 5.01** Elevator set should be maintained from within the elevator cab, and the telephone line from points outside the elevator shaft.
- 5.02** Report trouble in elevator cables between base and connecting block or terminal to the superintendent or other responsible persons in charge of elevator maintenance.
- 5.03** If handset cord is defective, remove cord from faceplate assembly and install replacement cord. If base is equipped with an H4DB handset cord, it may be replaced by a H4DU cord if 227D and 231B adapters are installed in the hand telephone set and handset cord jack of the mounting plate assembly, respectively.
- 5.04** To release the H4DB handset cord plug (Fig. 8), use a KS-21107 type releaser or equivalent.

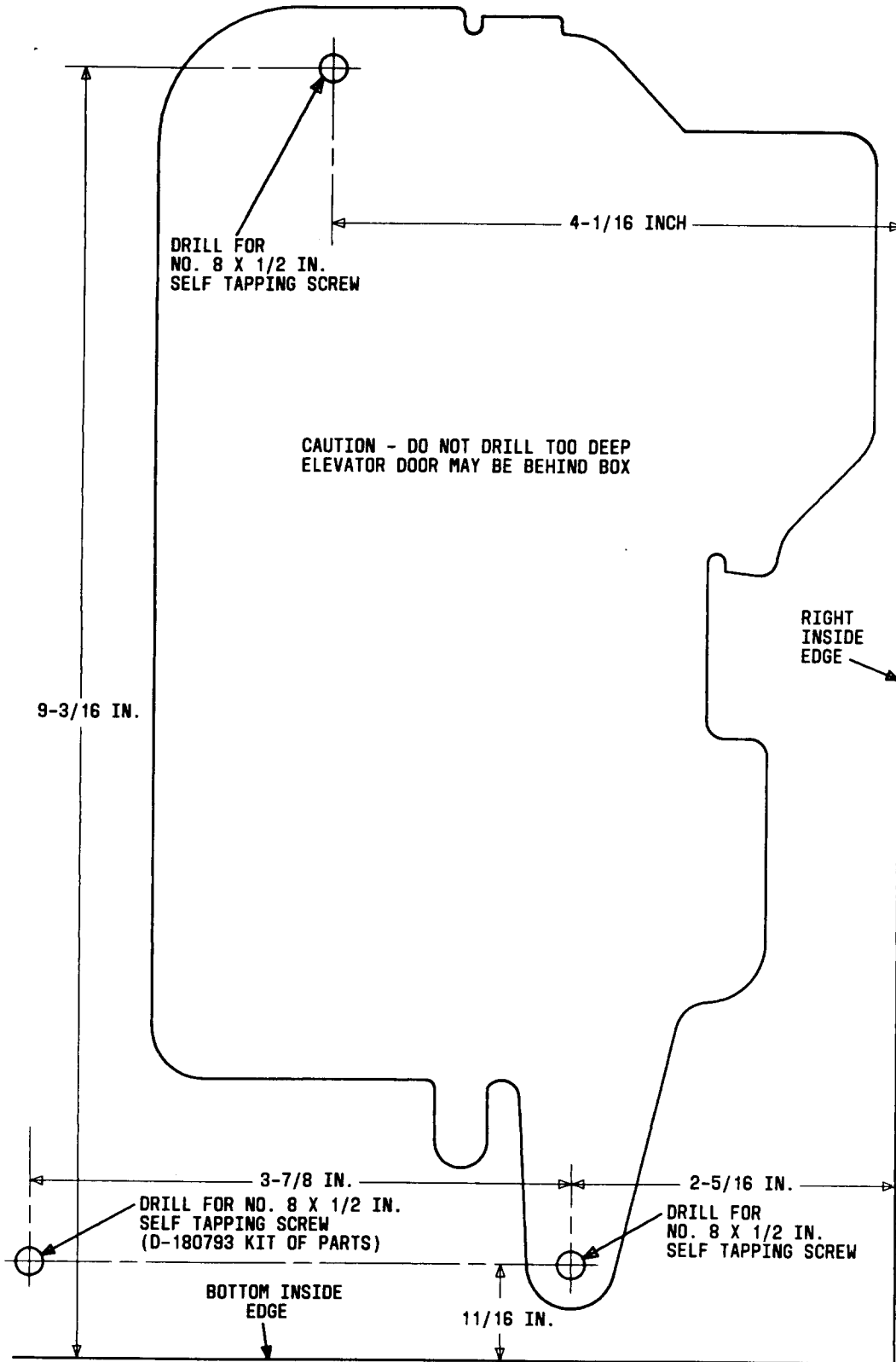

Fig. 6—Outlet Box Mounting Hole Drilling Information



Fig. 7— Mounting Location of D-180793 Kit of Parts in Outlet Box

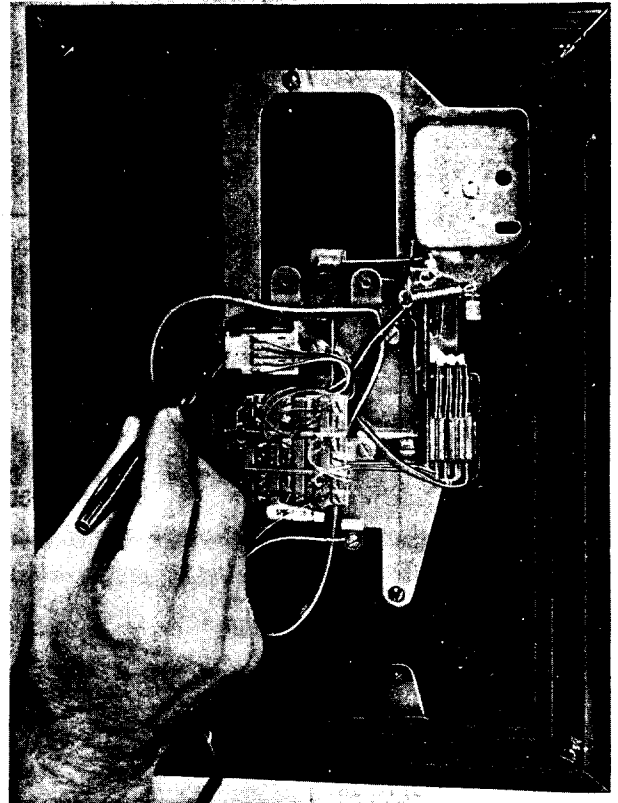
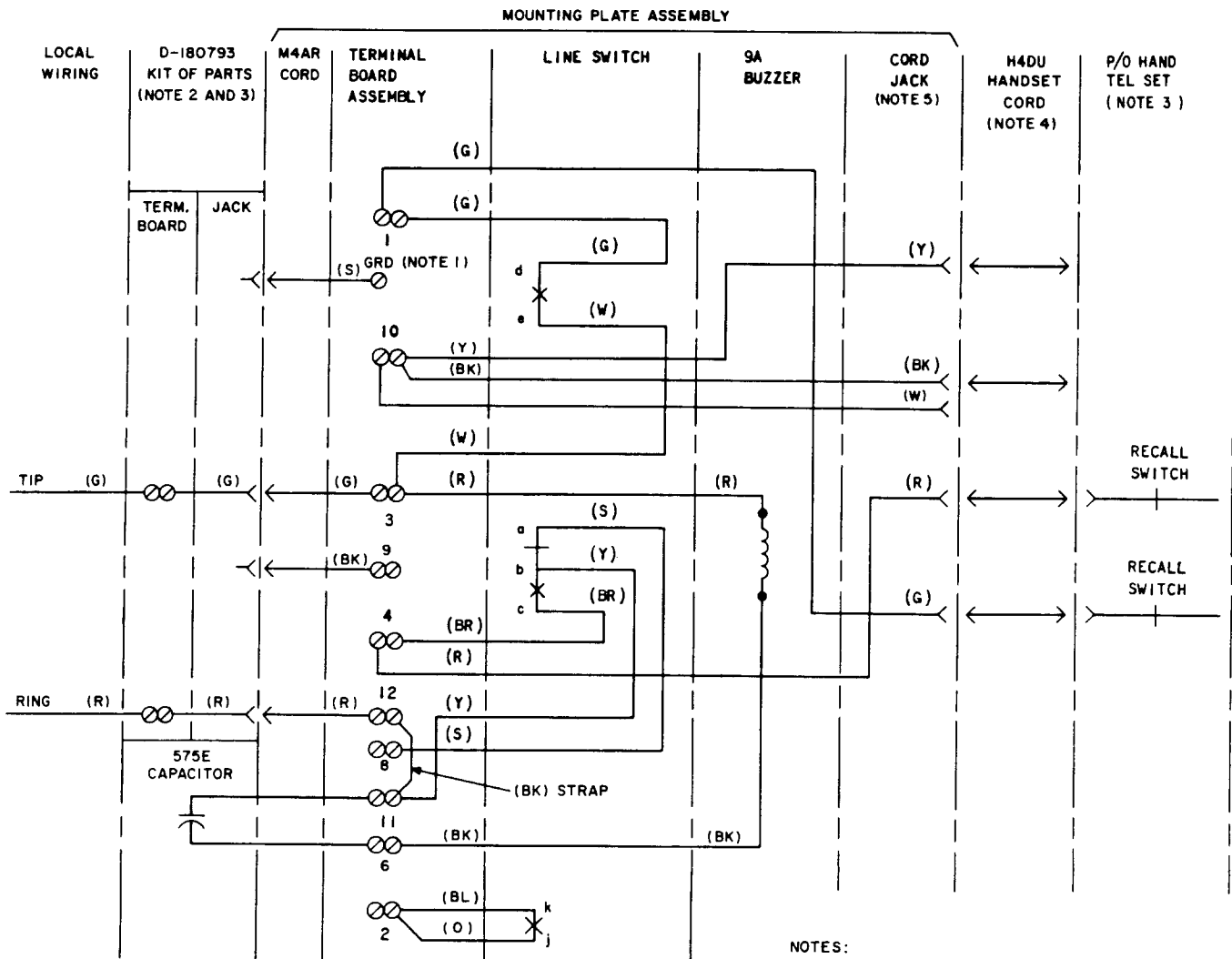

Fig. 8— Method of H4DB Handset Cord Removal and Location of Handset Cord Jack



- NOTES:
1. GRD TERMINAL IS LOCATED ON MOUNTING PLATE ASSEMBLY BELOW TERMINAL BOARD ASSEMBLY.
 2. MOUNTS IN D-95334 OUTLET BOX.
 3. MUST BE ORDERED SEPARATELY.
 4. FURNISHED WITH FACEPLATE ASSEMBLY.
 5. (W) CORD JACK LEAD IS FURNISHED IN EARLIER VERSION OF AL1 TELEPHONE BASE ONLY.

Fig. 9—AL1 Telephone Base and Hand Telephone Set, Connections