

SERVICE
622-TYPE TELEPHONE SETS

1. GENERAL

1.01 This section contains connections for 622A1 (MD) and 622A2 (MD) telephone sets. These sets are used in No. 5 Crossbar Systems arranged for customer group service.

1.02 Connection information for these sets was formerly contained in Section 502-620-401 which is hereby canceled.

2. CONNECTION INDEX

Fig. 1—Attendant Telephone Circuit

Fig. 2—Miscellaneous Keys and Lamps

Fig. 3—Pushbutton Dial

Fig. 4—Common Position Keys

Fig. 5—Destination and Source Lamps, 1 through 10

Fig. 6—Talk Keys and Key Lamps, 1 through 10

Fig. 7—Destination and Source Lamps, 11 through 20

Fig. 8—Talk Keys and Key Lamps, 11 through 20

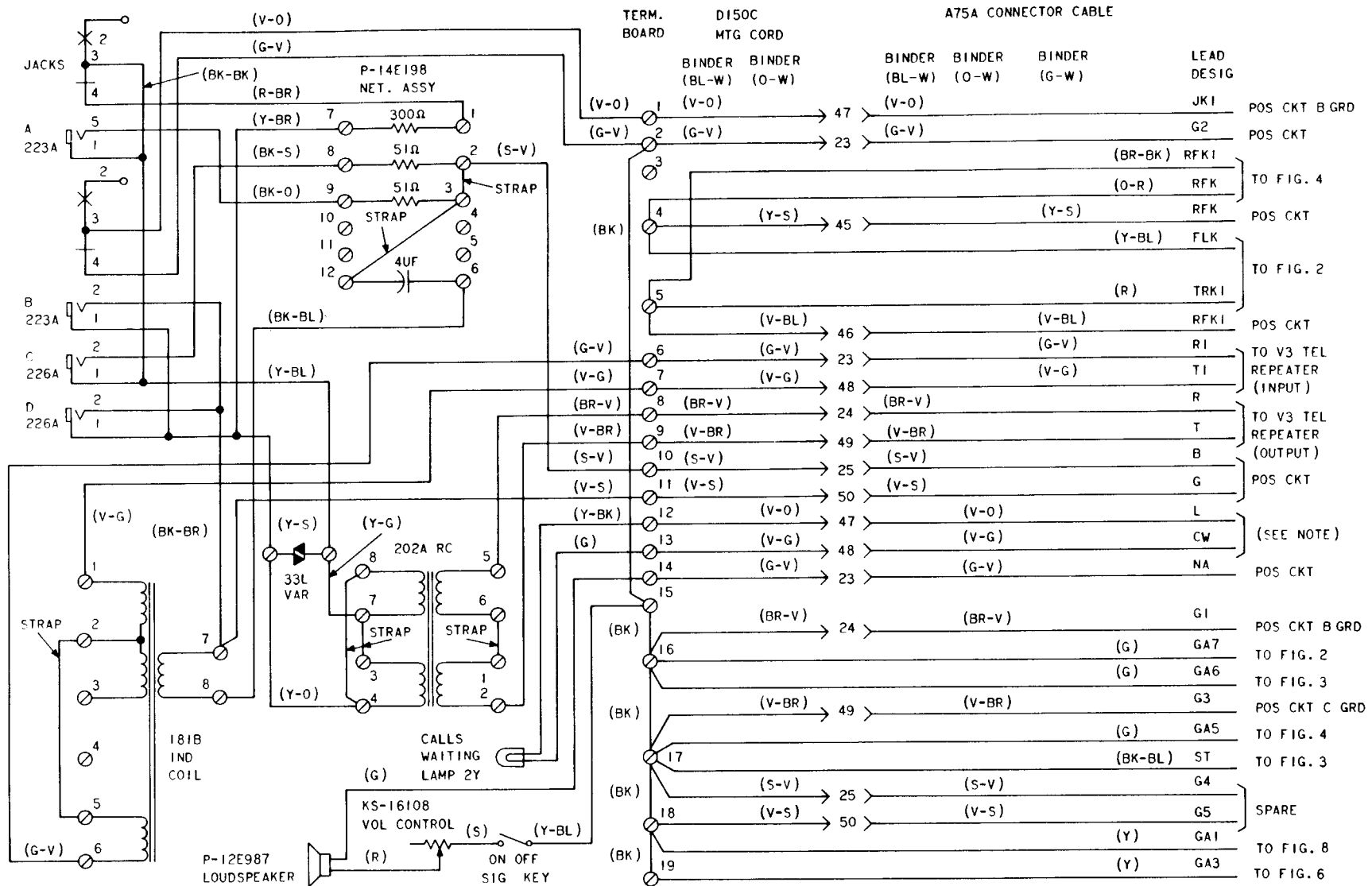

NOTE:
 WHEN THE EXTERNAL LOOP TO THE CW LAMP IS LESS THAN 50Ω. CONNECT THE CW LEAD TO -48 VOLT PBX BATTERY ON THE MDF AT THE CENTRAL OFFICE AND THE L LEAD TO THE CALLS WAITING SIGNAL CIRCUIT OR THE ATTENDANT TRUNK. WHEN THE EXTERNAL LOOP TO THE CW LAMP IS GREATER THAN 50Ω. CONNECT THE CW LEAD TO THE LOCAL LAMP BATTERY SUPPLY AND THE L LEAD TO THE LAMP REPEATING CIRCUIT, AND REPLACE 2Y CW LAMP WITH 2F-TYPE LAMP.

Fig. 1—Attendant Telephone Circuit

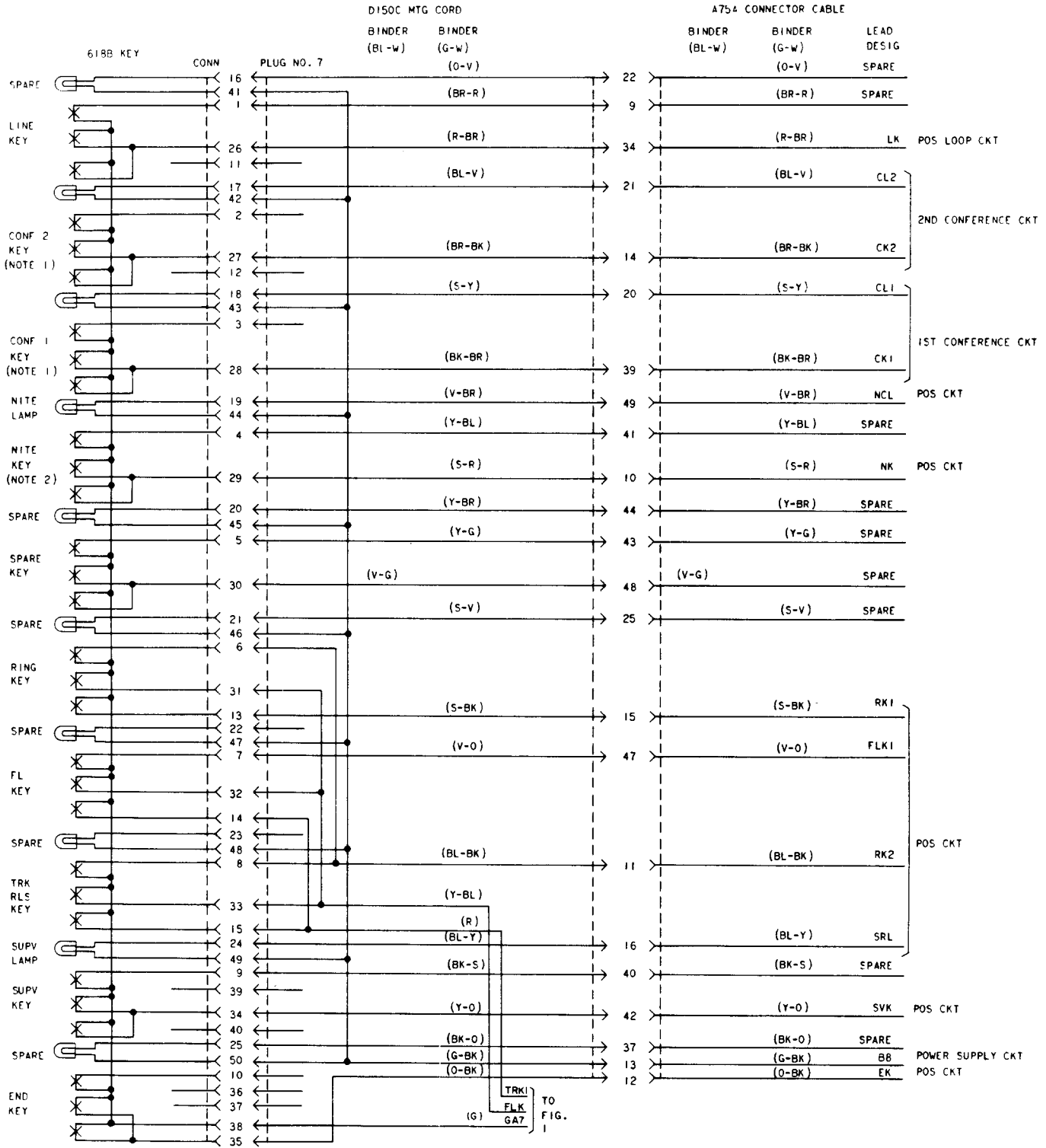

NOTES: 1. DESIGNATE ONLY ON POSITIONS INTENDED TO CONTROL CONFERENCE CONNECTIONS.
 2. DESIGNATE ONLY ON POSITIONS INTENDED TO CONTROL THE NITE CLOSING.

Fig. 2—Miscellaneous Keys and Lamps

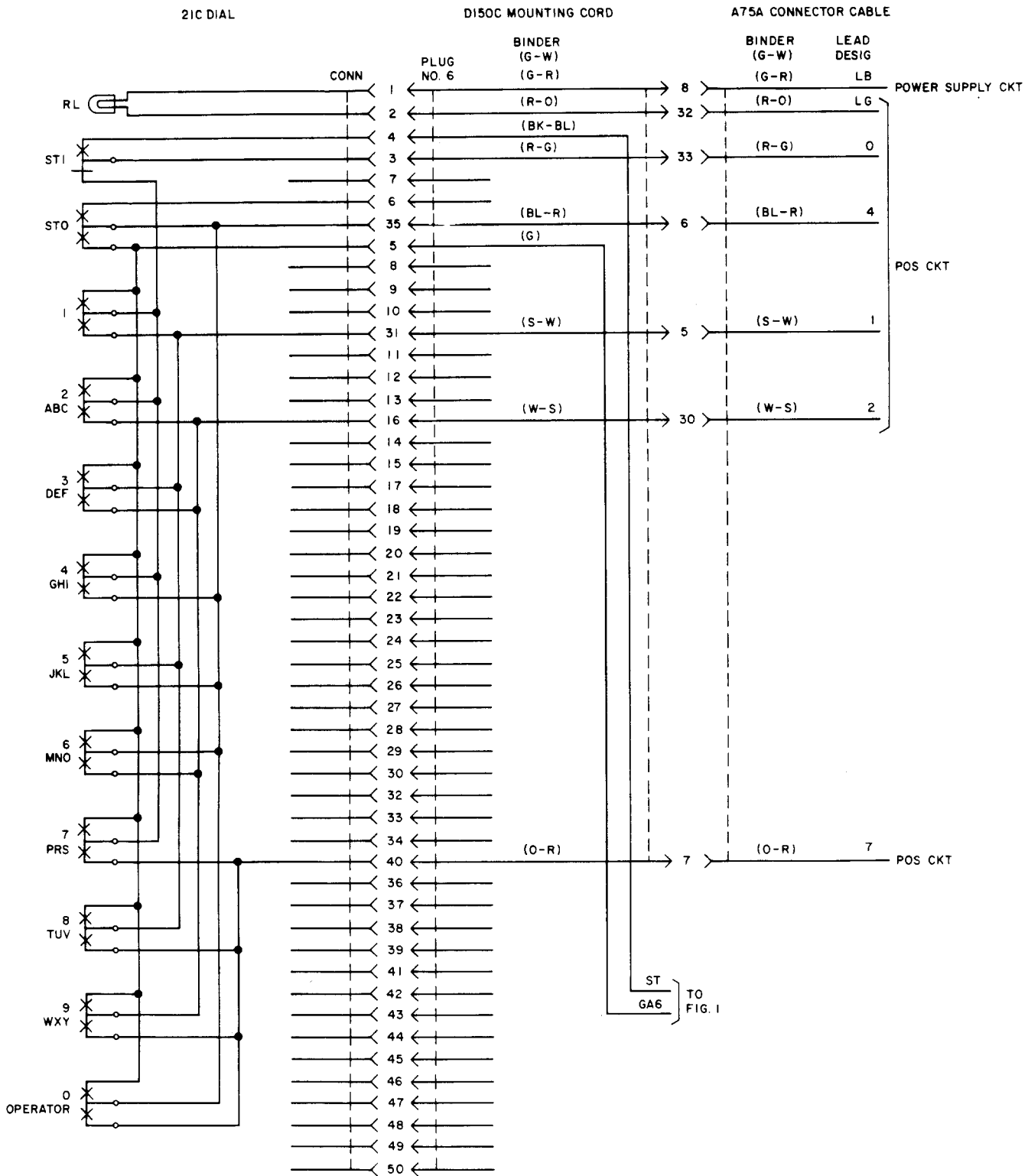

Fig. 3—Pushbutton Dial

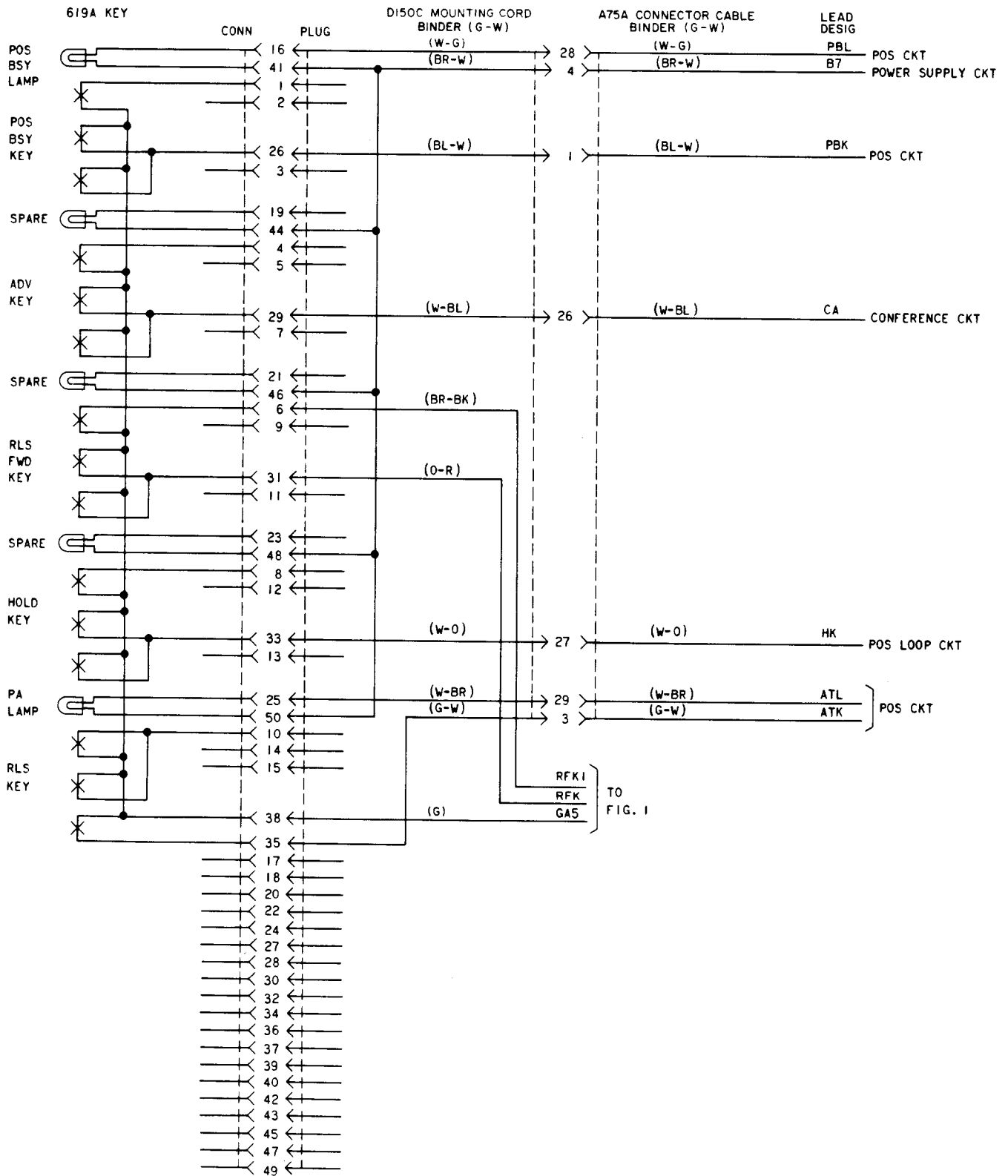

Fig. 4—Common Position Keys

SECTION 502-610-404

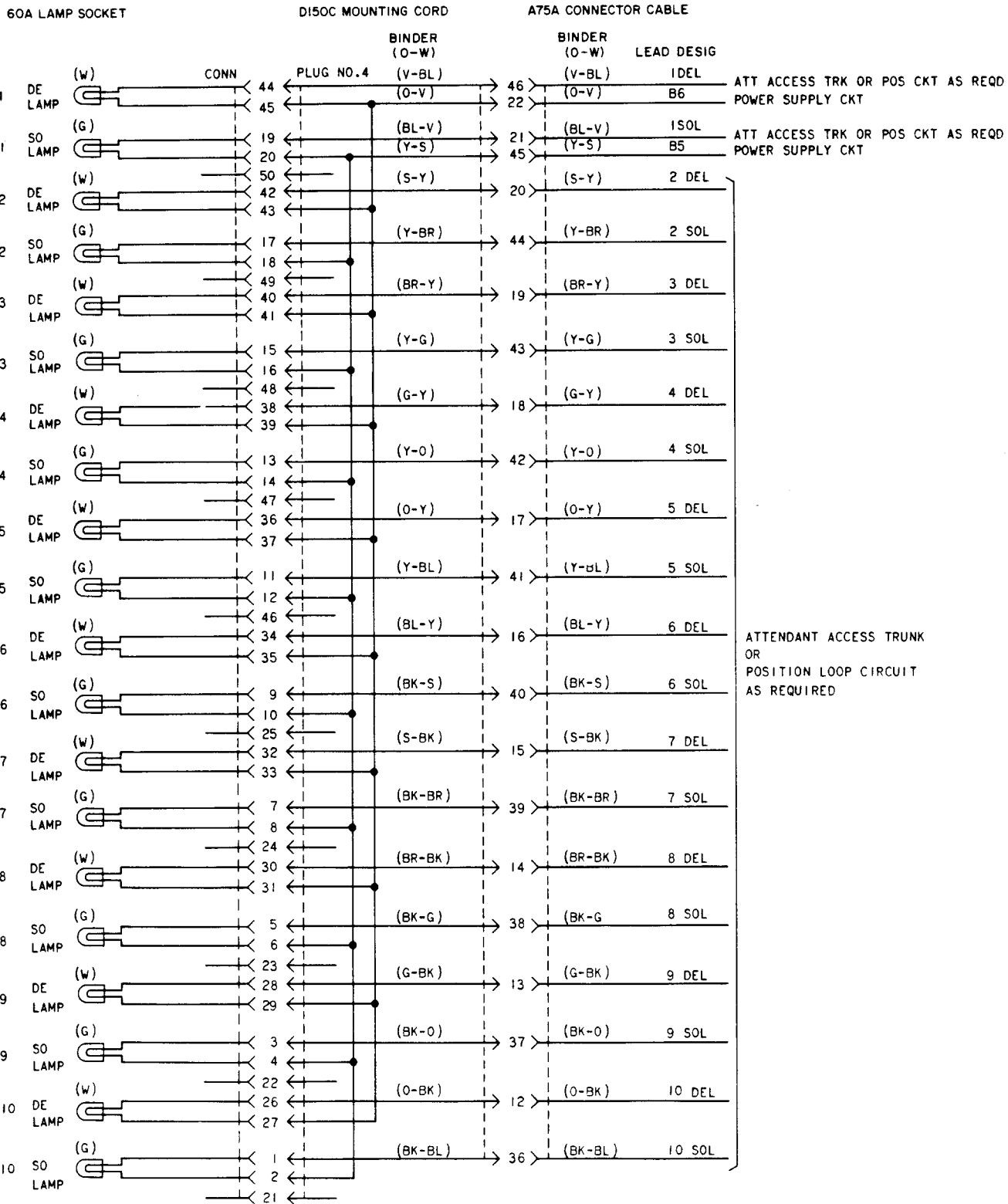

Fig. 5—Destination and Source Lamps, 1 through 10

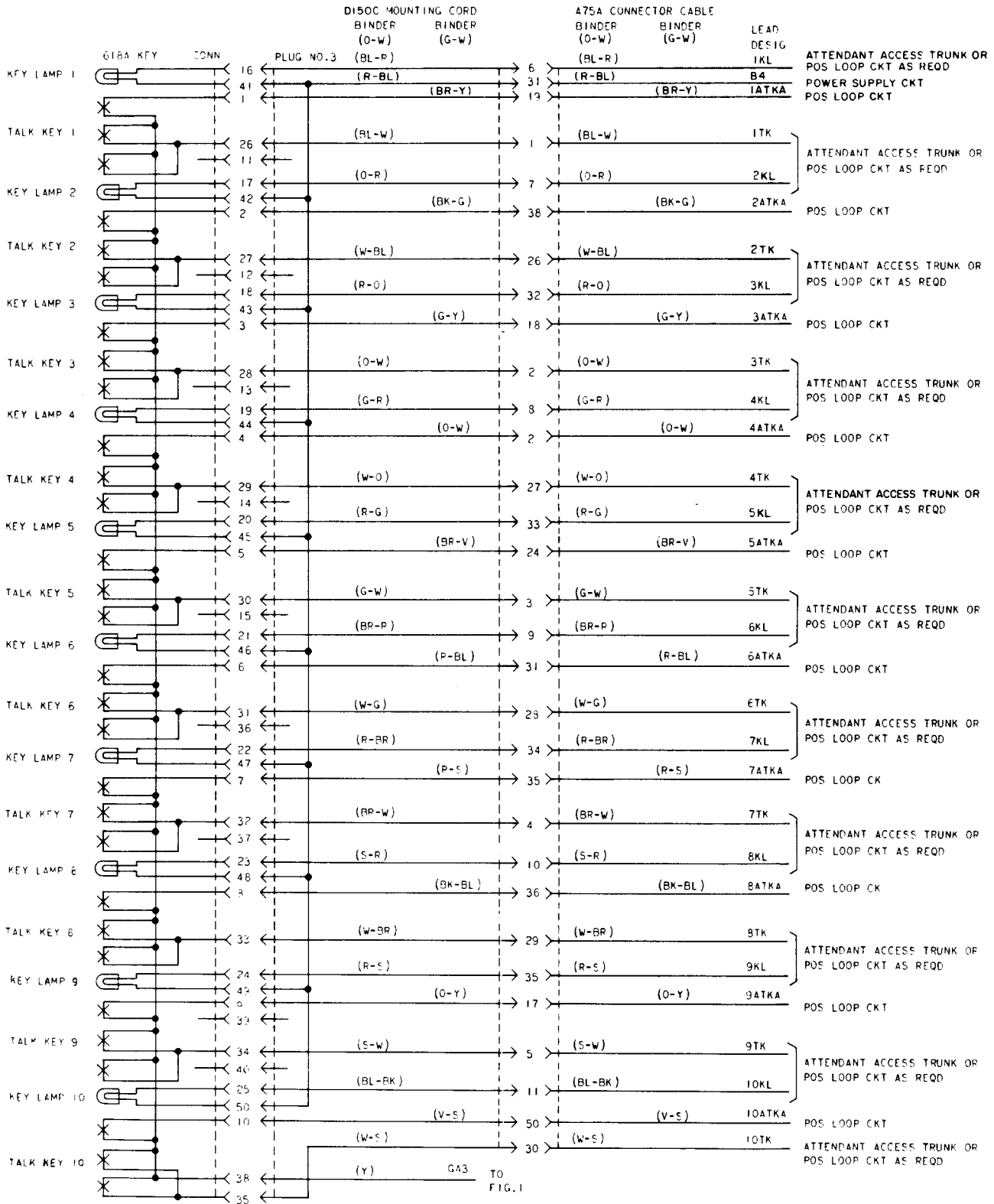

Fig. 6—Talk Keys and Key Lamps, 1 through 10

SECTION 502-610-404

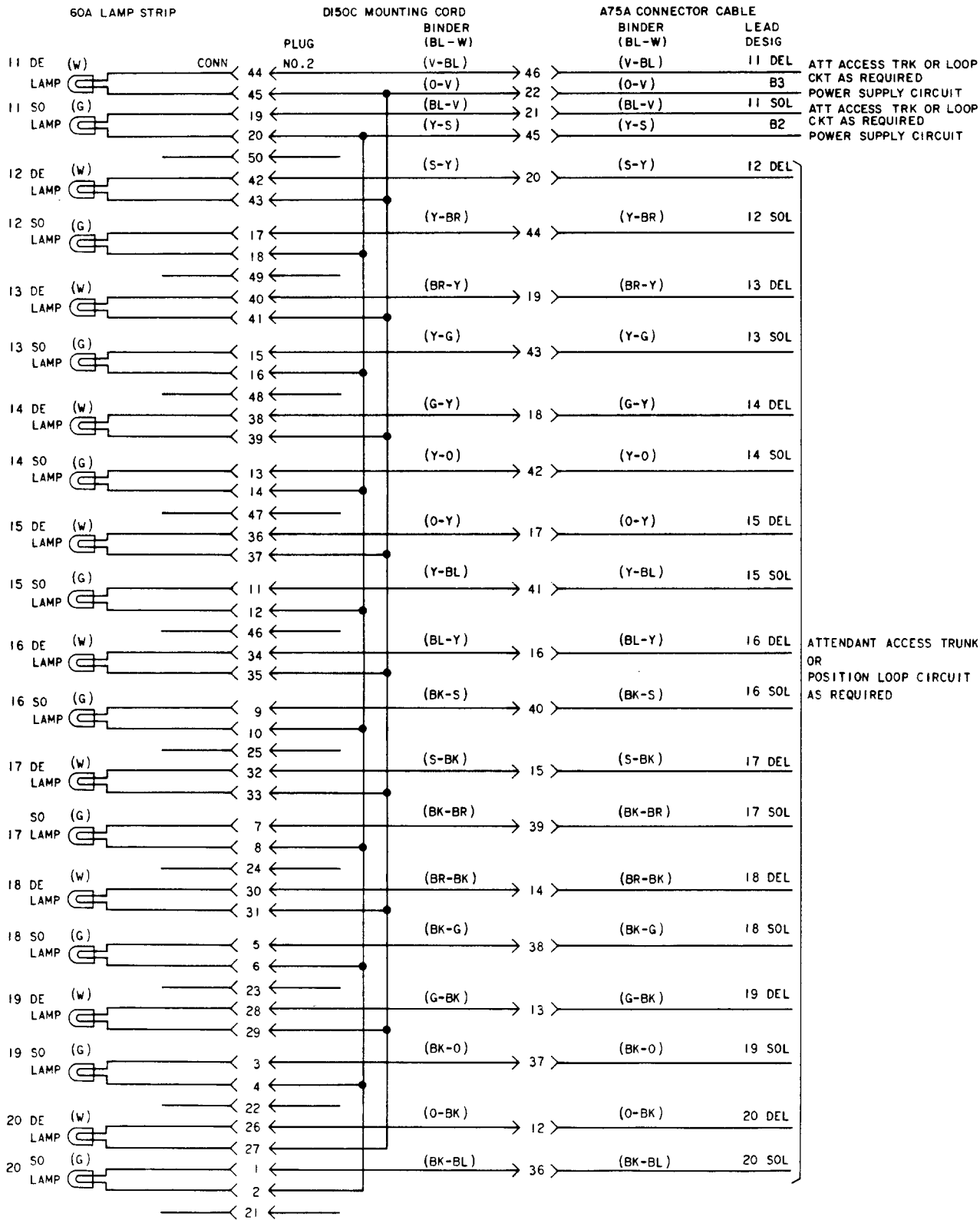

Fig. 7—Destination and Source Lamps, 11 through 20

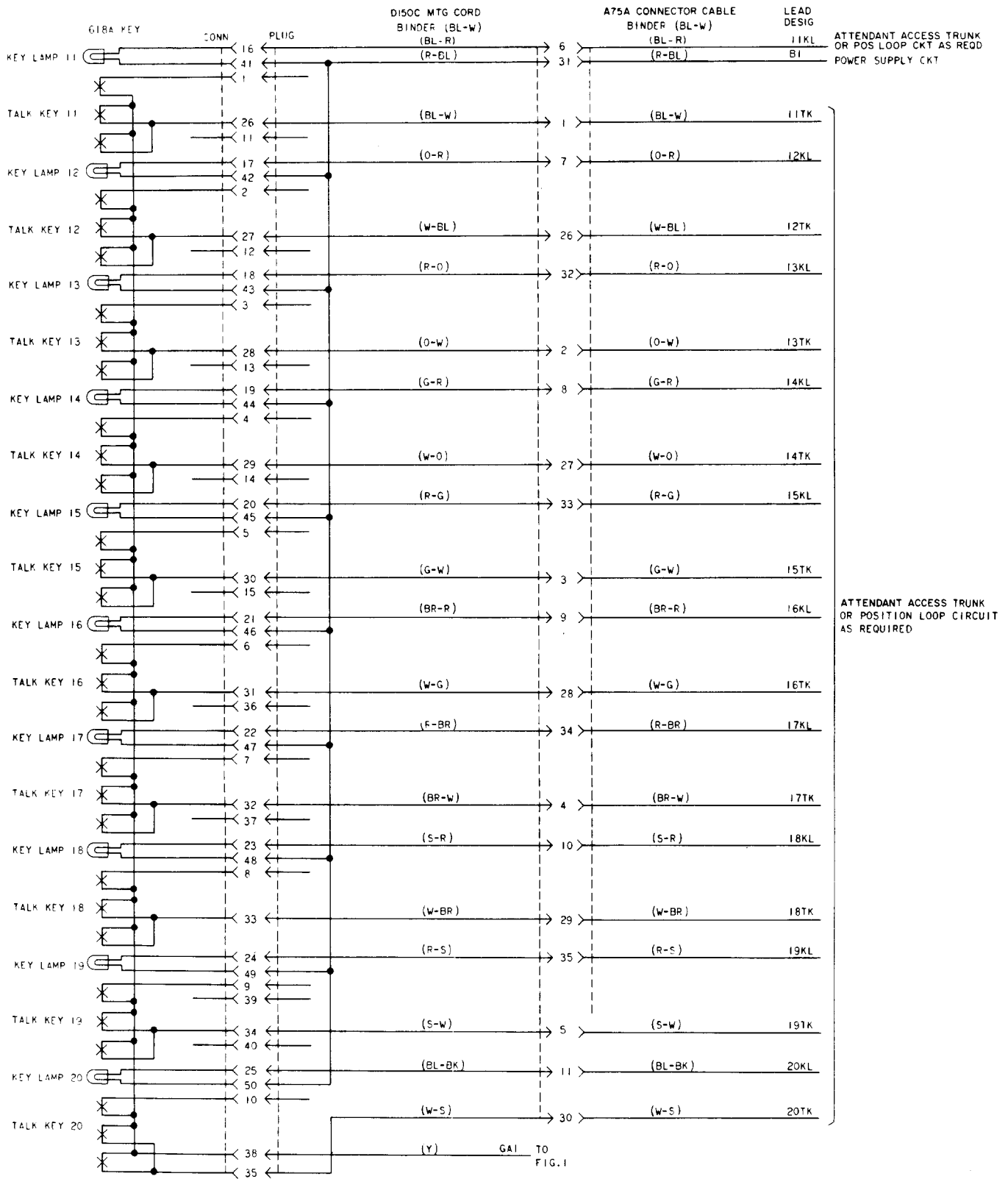

Fig. 8—Talk Keys and Key Lamps, 11 through 20