

## SERVICE

# 638CA, 638CAM, 638CAMS, 639DA, 639DAM, AND 639DAMS TELEPHONE SETS CONNECTIONS AND MAINTENANCE

### 1. GENERAL

**1.01** This section contains information for 638CA (MD), 638CAM (MD), 638CAMS (18-button) and 639DA (MD), 639DAM (MD), 639DAMS (30-button) CALL DIRECTOR® telephone sets equipped with rotary dials, headset jacks, and used with station line concentrators (Fig. 1, 2, and 3).

**1.02** This section is reissued to:

- Show 638CAM and 639DAM sets MD
- Add 638CAMS and 639DAMS coded sets.

**1.03** ♦All four letter coded sets are now furnished from the factory in only the numerical code (1), and all other numerical coded sets are rated MD. Sets may be equipped with different modular key arrangements by ordering the appropriate 635-, 658-type key, or 76A lamp socket. Refer to Section 502-601-101 for recommended layout arrangement of field-installed keys.

**1.04** The 638CAMS1 and 639DAMS1 sets are furnished equipped with a new line switch which breaks both the tip and ring side of the line instead of the ring side only.♦

**1.05** These sets are not intended for use with 3-type (MD) or 4A speakerphone systems or 1A key telephone systems.

### 2. CONNECTIONS

**2.01** See SD-69499-01 (key telephone systems, 6A, 6B, 1A1, and 1A2, station line concentrators) and appropriate sections in Division 518 for connections to station line concentrator using 235B or 236B key telephone units.

**2.02** A 235A (MD) or B KTU is associated with each 638-type telephone set. A 236A (MD) or B KTU is associated with each 639-type telephone set. Because of the single common talking pair and control lead patterns used in these sets, a line concentrator unit must be associated with each telephone set installed and cannot be shared, even on a bridged station basis.

**2.03** When 400-type KTU's are used as line circuits, a 235B or 236B KTU must be used or a 235A (MD) or 236A (MD) KTU modified as shown in the section on station line concentrators in Division 518.

**2.04** These telephone sets are equipped with either a 241A (MD) or 241B amplifier. Connections for both amplifiers are the same.

**2.05** The 638- and 639-type sets that are provided with D50AH (MD) or D80D (MD) mounting cords require contact strip assemblies on the 635-type keys. These sets are normally provided with a 635A5C key (5-line pickup and hold) in the first module. If desired, the 635A5C key can be replaced with a 635AD5C key (4-line pickup, cutoff, and hold). In this case the contact strip assemblies for the 635AD5C key (840151039 and 840151047) are furnished with the key.

**Note:** Contact strips are not required with sets equipped with D50BD or D80E mounting cord. A and A1 are common to all pickup buttons through internal mounting cord wiring.

**2.06** Because of the physical arrangement of the 635-type key, the contact strips do not extend to the chaining switch. This requires additional A1 leads to each module (except the last) to provide A lead control.

### NOTICE

Not for use or disclosure outside the  
Bell System except under written agreement

**2.07** Mounting cords of these CALL DIRECTOR sets terminate in individual plugs connected to the rear of the keys. This permits rearrangement of line appearance either in the set or at the key equipment distribution point. Current sets are equipped with the satin-silver (-87) mounting cord.

**2.08** The D50AH (MD) and D80D (MD) mounting cords are replaced by D50BD and D80E, respectively.

**2.09** All line key positions are convertible from pickup (locking) to signaling (nonlocking). To convert a key position, remove the 812857738 (P-28E773) screw detail from key position involved and make the necessary wiring changes as shown in Table A or B.



***Some spade-tipped conductors or mounting cord leads are insulated with tubing which, when used, should be cut off with electrician scissors or diagonal pliers. Other conductors are insulated with stiff plastic pockets. Pinch open the mouth to release the spade tips.***

**2.10** The 819040338 (P-90D033) Printed Wiring Board Assembly used to provide a station busy lamp circuit for 638- and 639-type telephone

sets is intended to mount in the 235- or 236-type line concentrator key telephone unit associated with these sets. Connections to the telephone set are through the TA lead (Fig. 4 and 5). For connections to the Printed Wiring Board Assembly refer to Division 518 and SD-69580-01.

**2.11** A KS-8109L2 or KS-20419L1 buzzer may be installed when a second audible signal is required. Use (O-R) and (R-O) mounting cord conductors from (BL) binder stored in first module for connections. Current sets are equipped with a KS-20419L1 (10 volt ac only) buzzer connected as shown.

### **3. MAINTENANCE**

**3.01** Maintenance information for these sets is found in Division 502, Section entitled 630, 1630, and 2630 Series Telephone Sets, Common Installation and Maintenance Information.

**3.02** Individual components such as dials, keys, ringers, etc, are covered in sections pertaining to the particular item.

**3.03** ***Do not use solvents to clean plastic parts of these sets.*** Use a damp cloth only. If discolored, replace part.

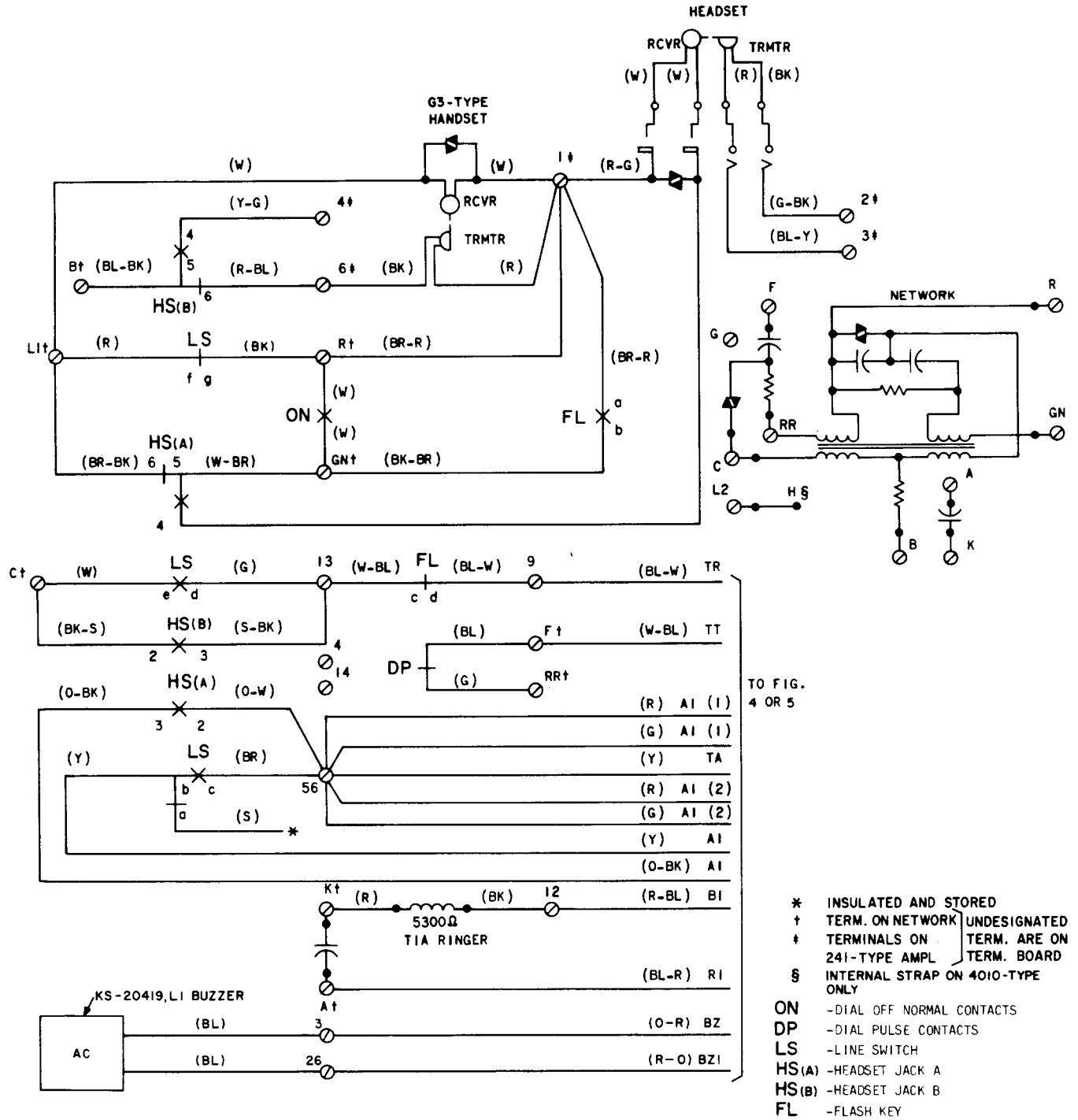

Fig. 1—638CA (MD) and 639DA (MD) Telephone Set, Connections

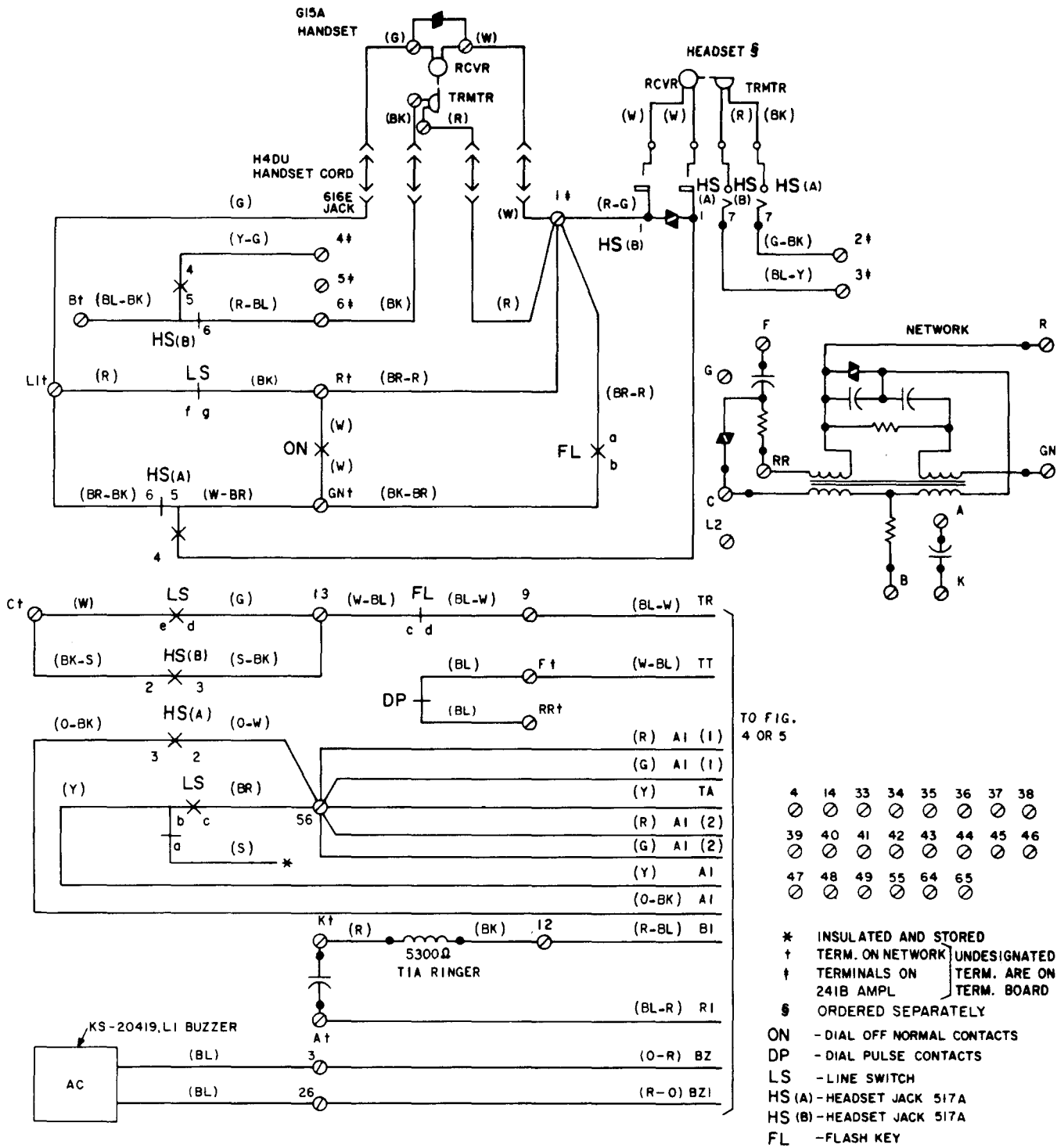

Fig. 2—638CAM (MD) and 639DAM (MD) Telephone Set, Connections

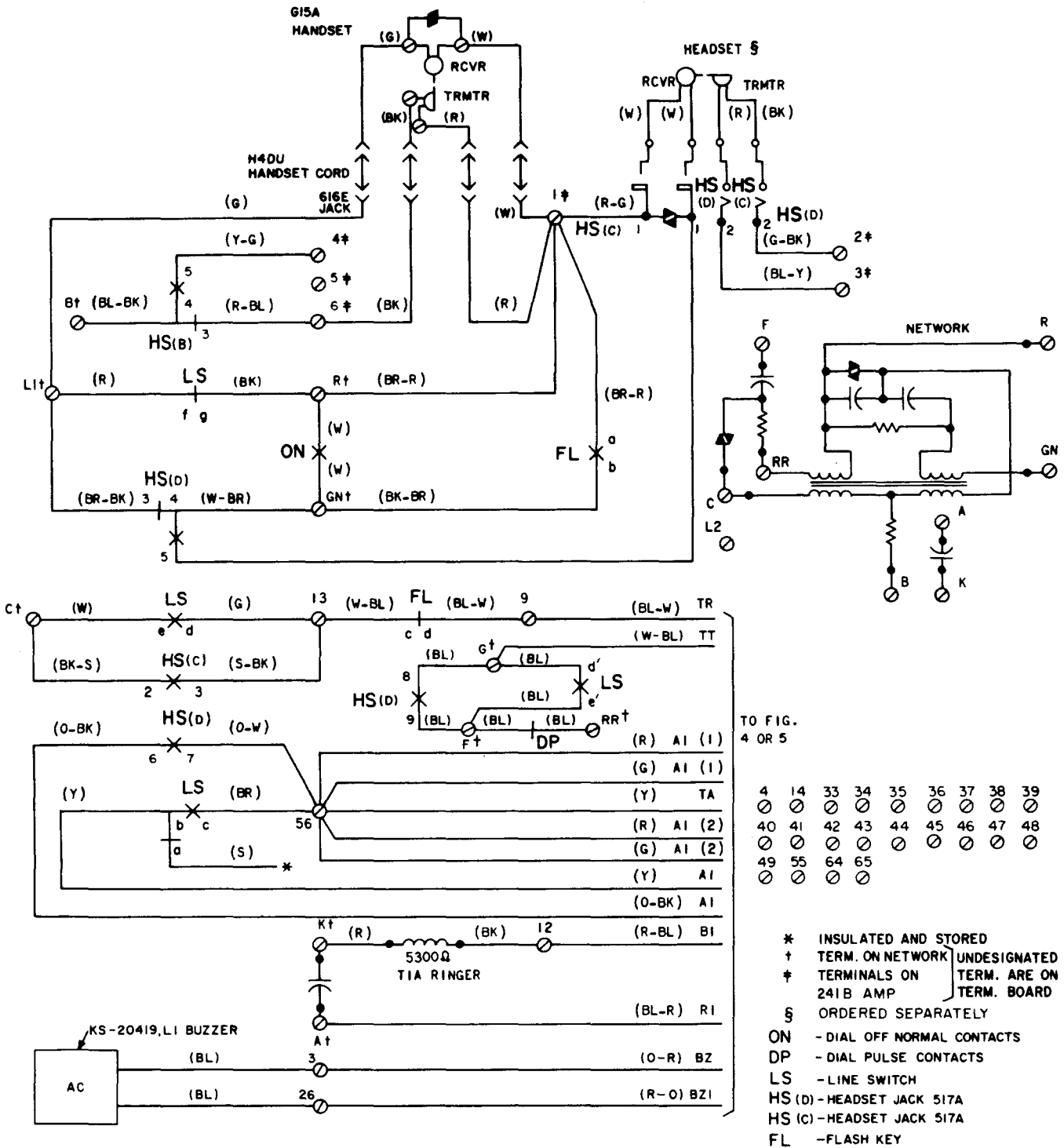

Fig. 3—638CAMS and 639DAMS Telephone Set Connections

**SECTION 502-610-419**

NOTES FOR FIGURES 4 AND 5:

1. THE 635AD5C KEY IS SUPPLIED WITH AN ADAPTER IN THE CUTOFF KEY POSITION. IN SETS EQUIPPED WITH D50AH (MD) OR D80D (MD) MOUNTING CORD, CONTACT STRIP ASSEMBLIES 840151039 AND 840151047 FURNISHED WITH THE 635AD5C KEY REPLACE THE 840151120 AND 840151138 ASSEMBLIES USED WITH THE 635A5C KEY. THE SLATE MOUNTING CORD PLUG CONNECTS TO THE ADAPTER. BALANCE OF PLUGS CONNECT DIRECTLY TO KEY.
2. IF A 635AD5C KEY IS ADDED IN THE FIELD, FOR RINGER CUTOFF TERMINATE THE (BL-Y) ADAPTER LEAD AS INDICATED IN NOTE 6 AND REMOVE (R) SLATE PLUG LEAD FROM TERMINAL 22, INSULATE AND STORE.
3. IF THE HOLD POSITION LAMP (6TH) 635A5C OR 635AD5C KEY IN THE FIRST MODULE IS USED FOR A VISUAL SIGNAL, REMOVE (Y-G) LAMP GROUND LEAD FROM STORED LOCATION IN FIRST MODULE AND CONNECT TO TERMINAL 22. CONNECT THE (G-Y) LAMP LEAD FROM THE PINK PLUG AND THE (R-G) LEAD FROM THE MOUNTING CORD USING A SPARE TERMINAL OR D-161488 CONNECTOR.
4. IN SETS EQUIPPED WITH A 658A KEY, THE (G) CONTACT STRIP OR PLUG STRAP LEAD IS TERMINATED ON TERMINAL 10 AND (R) ON 11. IF A 658A KEY IS ADDED IN THE FIELD, LEADS MUST BE MOVED FROM PRECEDING MODULE CHAINING CIRCUIT TO TERMINALS 10 AND 11. PROVISIONS ARE MADE FOR MECHANICALLY STORING THE LIGHT BEIGE PLUG ON THE 658A KEY. NO ELECTRICAL CONNECTION IS MADE.
5. WHEN THE 658A KEY IS REQUIRED AS A DUAL PURPOSE KEY, REMOVE STRAP BETWEEN TERMINALS 10 AND 11. USE M1W CORD OF EQUIVALENT TO CONNECT TERMINAL 11 TO A GROUND OTHER THAN SIGNAL GROUND.
6. CUTOFF OF THE INTERNAL RINGER CAN BE PROVIDED USING THE 635AD5C KEY IN THE FIRST MODULE. TRANSFER B1 (R-BL) LEAD FROM TERMINAL 12 AND (BL-Y) ADAPTER LEAD TO SAME SPARE TERMINAL OR D-161488 CONNECTOR. REMOVE (W-G) LEAD (SLATE PLUG) FROM TERMINAL 57 AND CONNECT TO 12.
7. WHEN 635AD5C KEY IS USED IN THE FIRST MODULE TO PROVIDE CUTOFF, SWITCHING, OR TRANSFER FEATURES, MOVE (W-BR) SLATE PLUG LEAD FROM TERM. 60 TO TERMINAL 11. THESE SERVICE FEATURES ARE PROVIDED BY AN AUXILIARY RELAY (229B KTU OR EQUIVALENT) SEPARATELY MOUNTED AND CONTROLLED BY THE CUTOFF KEY CONTACTS THROUGH LG5, C, S, S1 LEAD.
8. CONTROL LEADS CA THROUGH CH, AND CJ ARE CONNECTED TO TERMINALS 57 TO 65. THESE TERMINALS APPEAR ON MORE THAN ONE OF THE MODULE SHEETS OF FIG. 4 AND 5 BUT ARE THE SAME TERMINAL.
9. THESE CONTACT STRIPS ARE REQUIRED WHEN TELEPHONE SET IS EQUIPPED WITH THE D50AH (MD) OR D80D (MD) MOUNTING CORD. THESE CONTACT STRIPS SHOULD NOT BE USED WHEN TELEPHONE SET IS EQUIPPED WITH THE D50BD OR D80E MOUNTING CORD.

- |                        |                                 |
|------------------------|---------------------------------|
| * INSULATED AND STORED | ‡ LEAD COLOR IN D50BD MTG. CORD |
| † DEAD DRESSED         | § LEAD COLOR IN D80E MTG. CORD  |

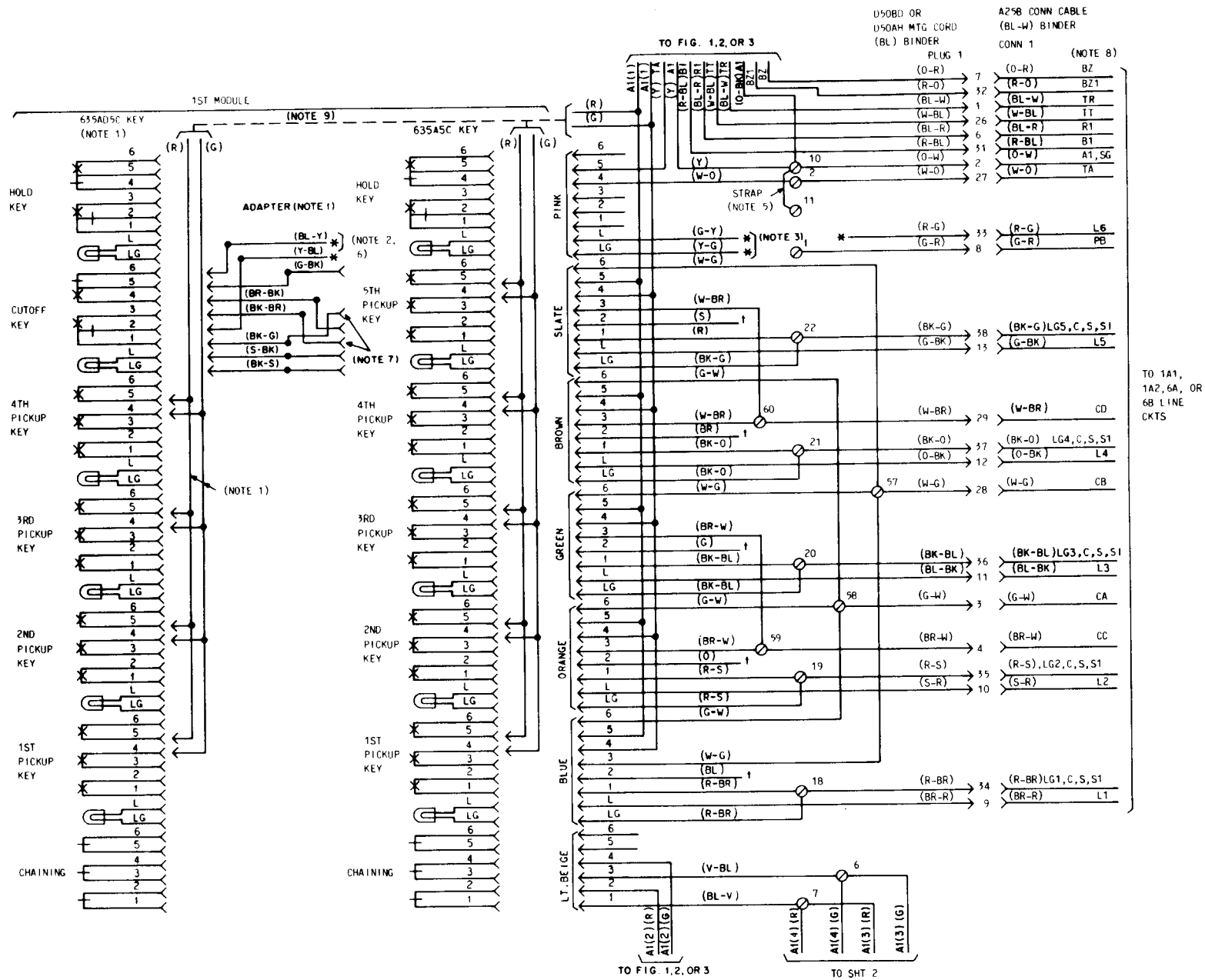

Fig. 4—638CA (MD), CAM (MD), and CAMS Telephone Set Module and Connector Cable Arrangements  
(Sheet 1 of 3)

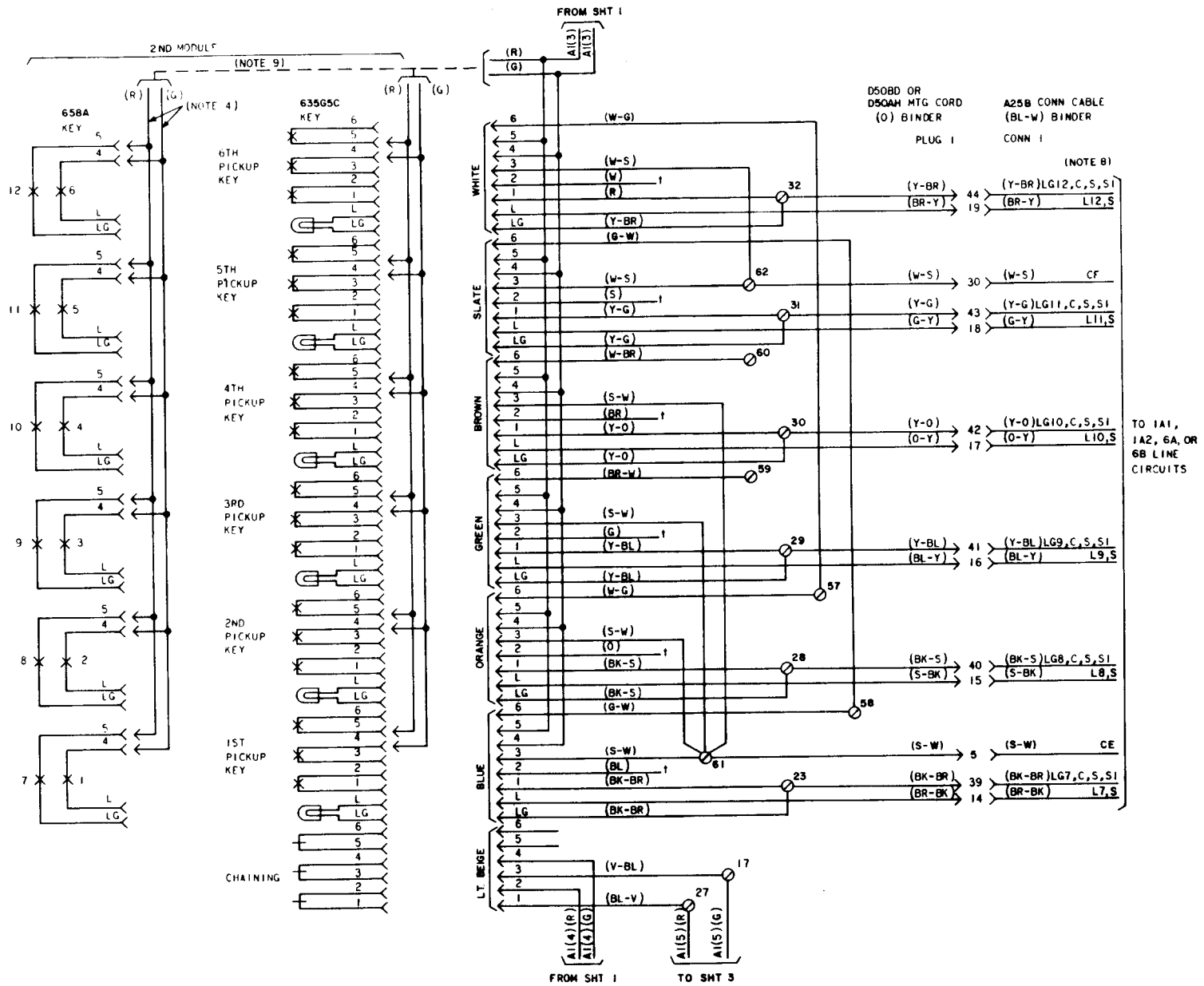

Fig. 4—638CA (MD), CAM (MD), and CAMS Telephone Set Module and Connector Cable Arrangements (Sheet 2 of 3)



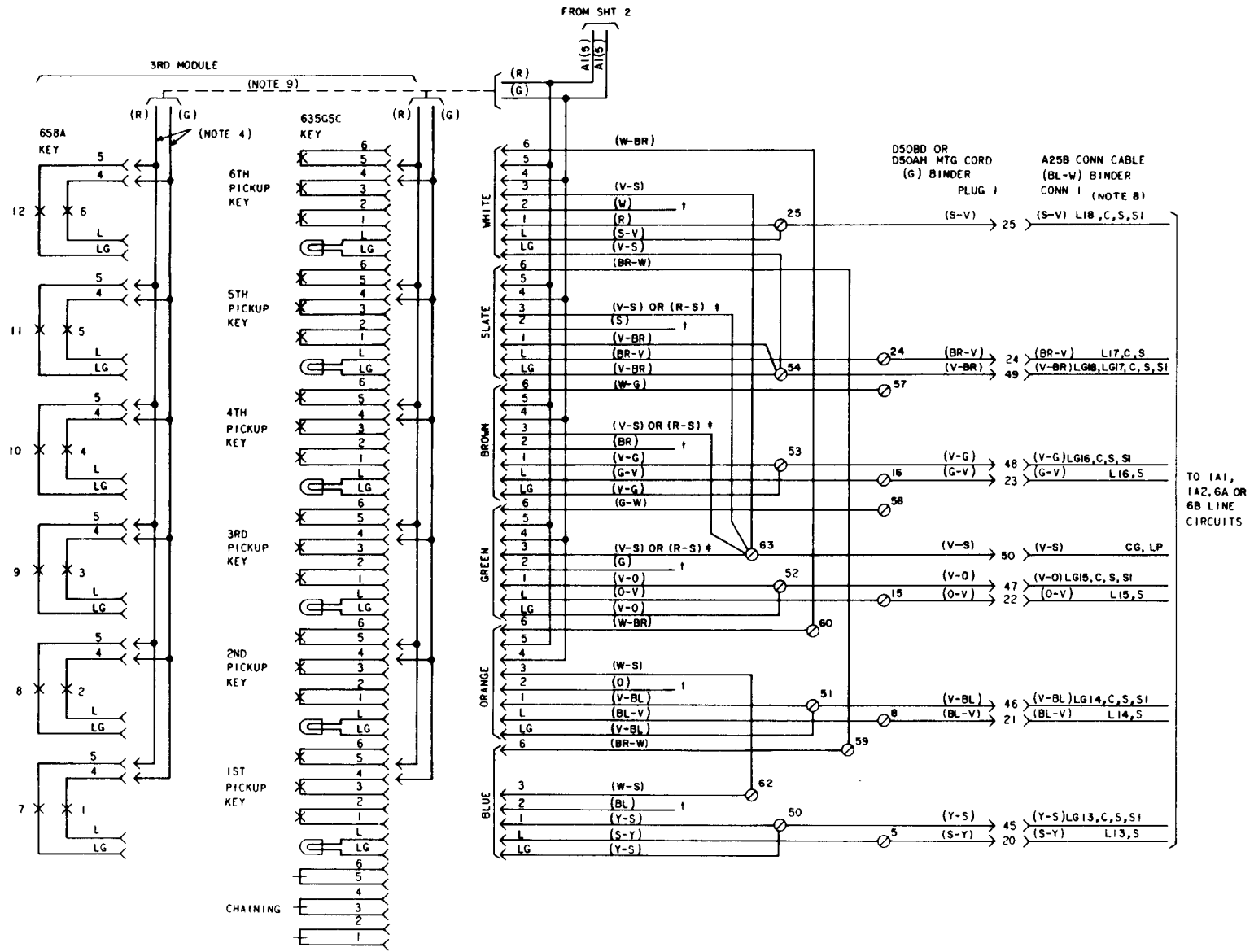

Fig. 4—638CA (MD), CAM (MD), and CAMS Telephone Set Module and Connector Cable Arrangements (Sheet 3 of 3)

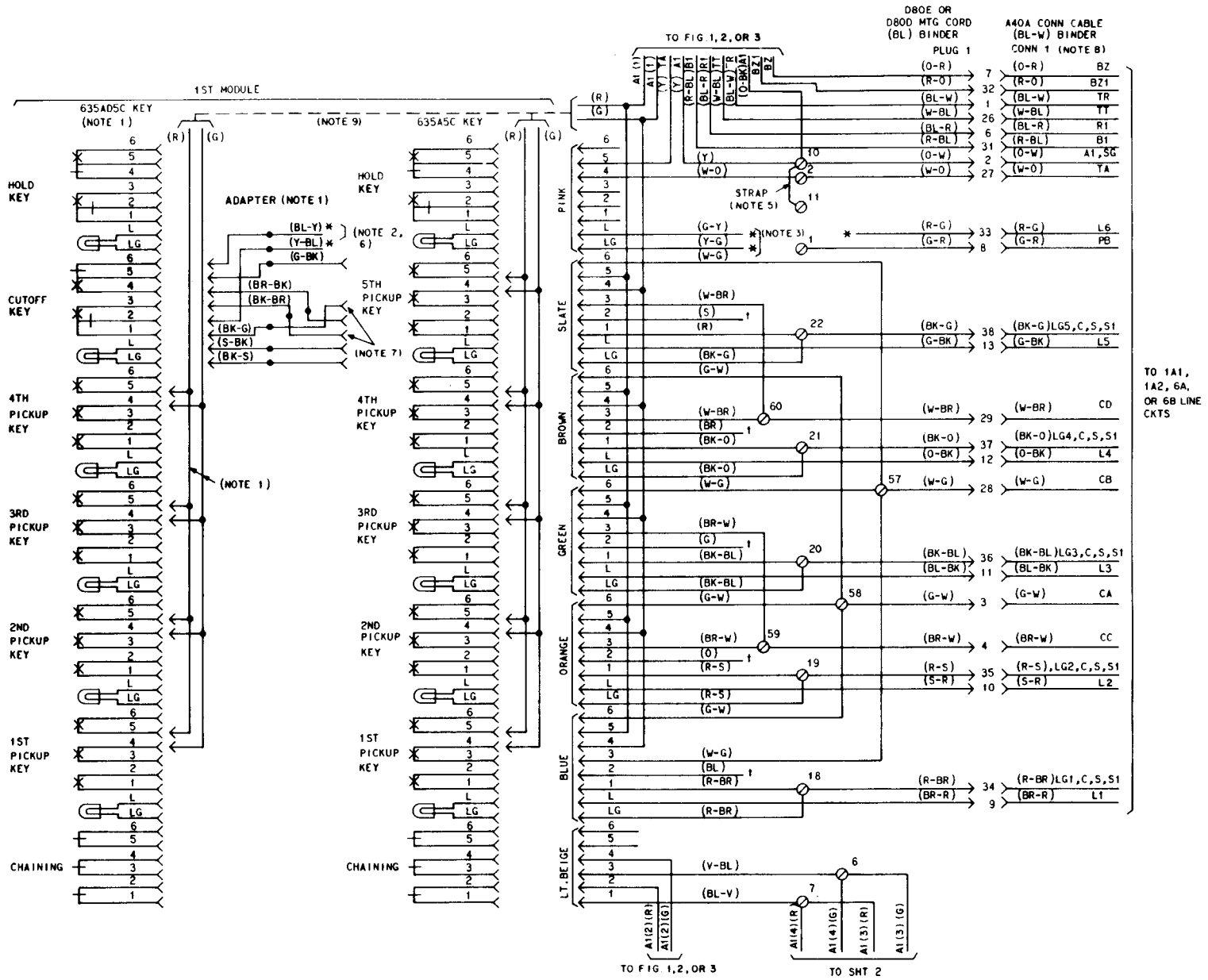

Fig. 5—639DA (MD), DAM (MD), or DAMS Telephone Set Module and Connector Cable Arrangements (Sheet 1 of 5)

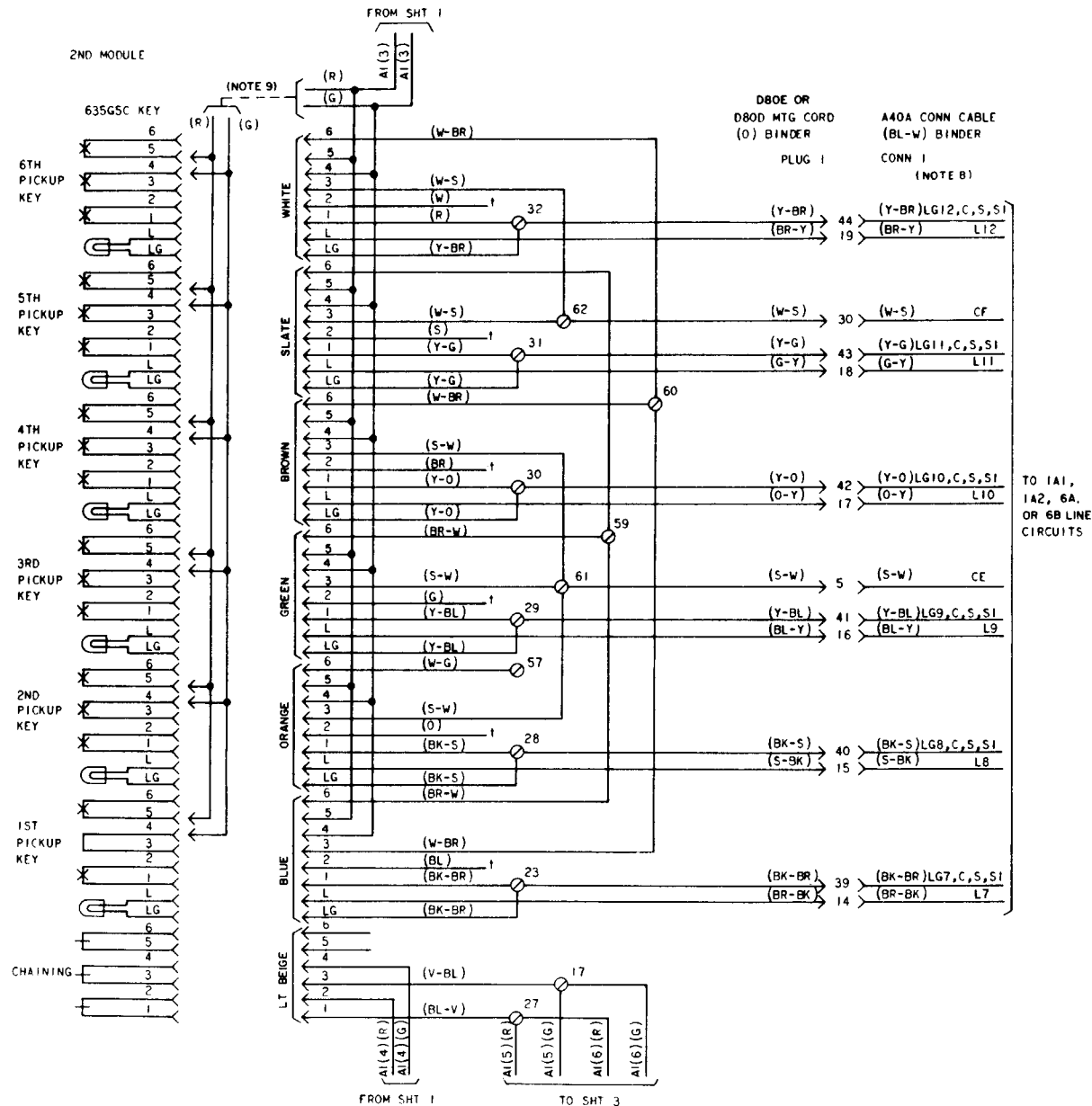

Fig. 5—639DA (MD), DAM (MD), or DAMS Telephone Set Module and Connector Cable Arrangements (Sheet 2 of 5)¶

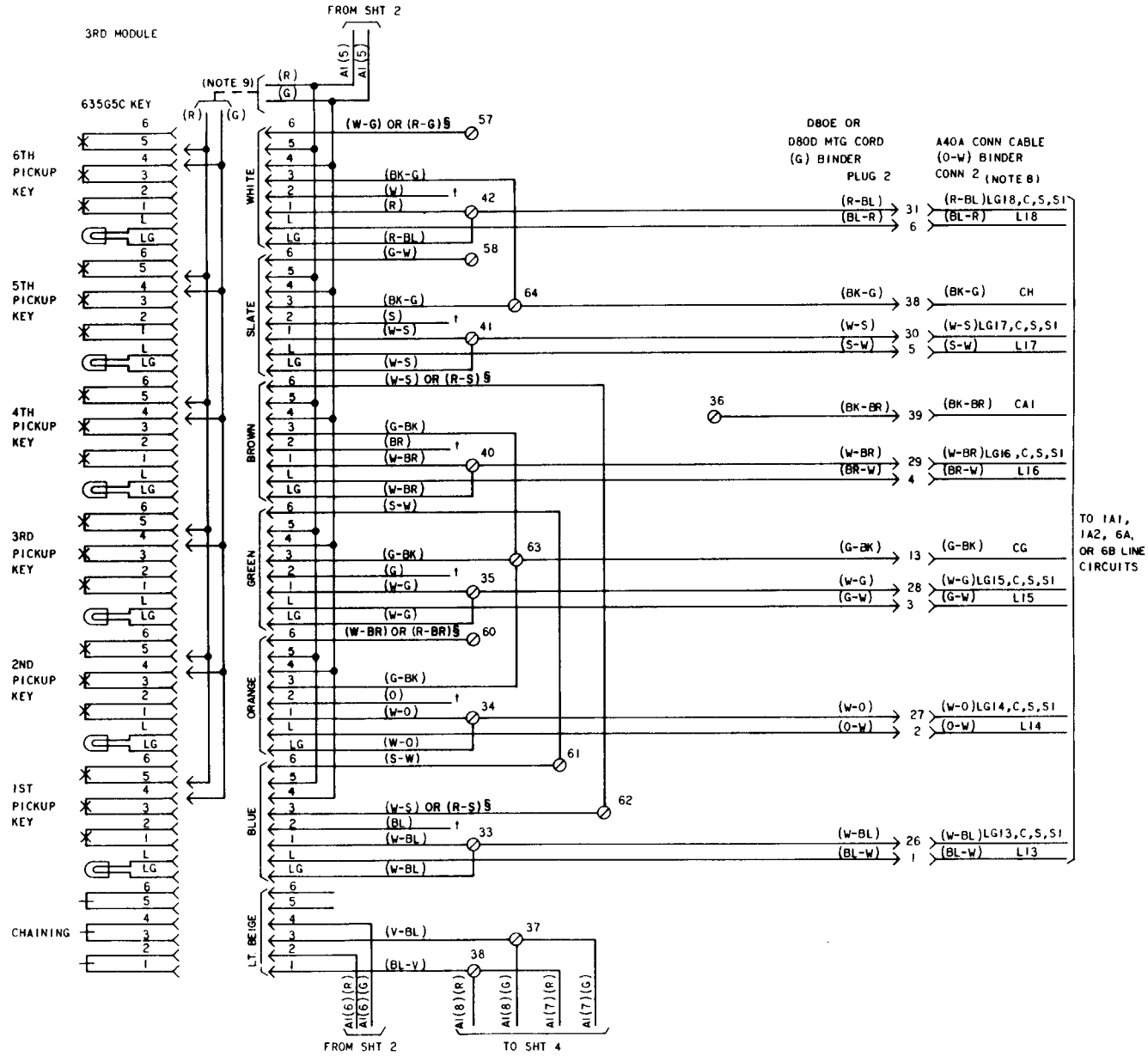

Fig. 5—639DA (MD), DAM (MD), or DAMS Telephone Set Module and Connector Cable Arrangements (Sheet 3 of 5)



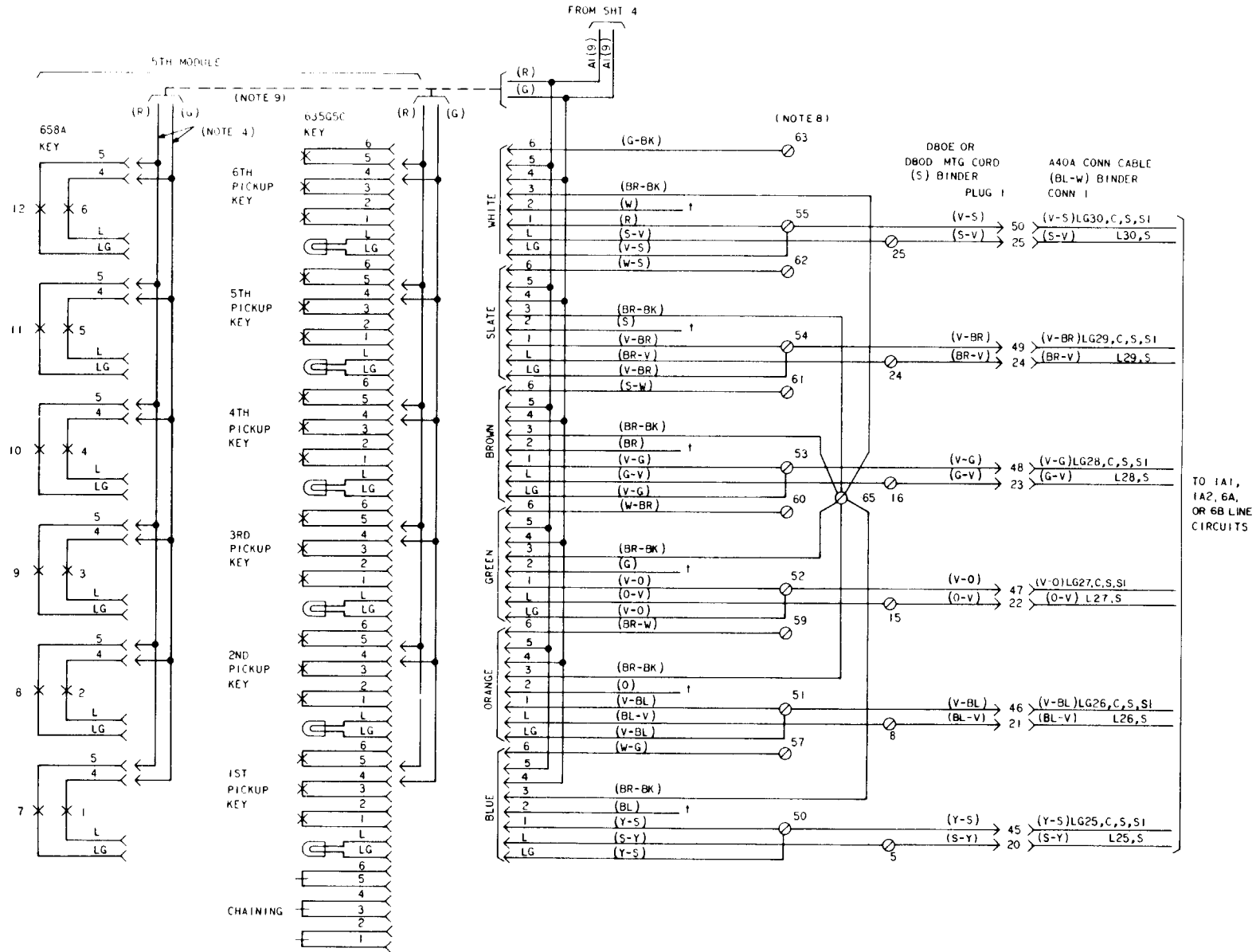

Fig. 5—639DA (MD), DAM (MD), or DAMS Telephone Set Module and Connector Cable Arrangements (Sheet 5 of 5)

TABLE A

PICKUP-SIGNAL KEY CONVERSION—THIRD MODULE, 638CA (MD), CAM (MD), AND CAMS TELEPHONE SET

NO. OF SIGNAL KEYS	KEY PLUG LEADS																							
	1ST PICKUP				2ND PICKUP				3RD PICKUP				4TH PICKUP				5TH PICKUP				6TH PICKUP			
	BL	Y-S	BR-W	W-S	O	V-BL	W-BR	W-S	G	V-O	G-W	V-S R-S‡	BR	V-G	W-G	V-S R-S‡	S	V-BR	BR-W	V-S R-S‡	W	V-S	W-BR	V-S
1	*	50	59	62	*	51	60	62	*	52	58	63	*	53	57	63	*	54	59	63	10	†	*	*
2	*	50	59	62	*	51	60	62	*	52	58	63	*	53	57	63	10	†	*	*	10	†	*	*
3	*	50	59	62	*	51	60	62	*	52	58	63	10	†	*	*	10	†	*	*	10	†	*	*
4	*	50	59	62	*	51	60	62	10	†	*	*	10	†	*	*	10	†	*	*	10	†	*	*
5	*	50	59	62	10	†	*	*	10	†	*	*	10	†	*	*	10	†	*	*	10	†	*	*
6	10	†	*	*	10	†	*	*	10	†	*	*	10	†	*	*	10	†	*	*	10	†	*	*

\* Insulated and stored.

† From LG terminal of plugs—insulate and store.

‡ Lead color in D50BD mounting cord.

TABLE B

PICKUP-SIGNAL KEY CONVERSION—FIFTH MODULE, 639DA (MD), DAM (MD), AND DAMS TELEPHONE SET

NO. OF SIGNAL KEYS	KEY PLUG LEADS																							
	1ST PICKUP				2ND PICKUP				3RD PICKUP				4TH PICKUP				5TH PICKUP				6TH PICKUP			
	BL	Y-S	W-G	BR-BK	O	V-BL	BR-W	BR-BK	G	V-O	W-BR	BR-BK	BR	V-G	S-W	BR-BK	S	V-BR	W-S	BR-BK	W	V-S	G-BK	BR-BK
1	*	50	57	65	*	51	59	65	*	52	60	65	*	53	61	65	*	54	62	65	10	†	*	*
2	*	50	57	65	*	51	59	65	*	52	60	65	*	53	61	65	10	†	*	*	10	†	*	*
3	*	50	57	65	*	51	59	65	*	52	60	65	10	†	*	*	10	†	*	*	10	†	*	*
4	*	50	57	65	*	51	59	65	10	†	*	*	10	†	*	*	10	†	*	*	10	†	*	*
5	*	50	57	65	10	†	*	*	10	†	*	*	10	†	*	*	10	†	*	*	10	†	*	*
6	10	†	*	*	10	†	*	*	10	†	*	*	10	†	*	*	10	†	*	*	10	†	*	*

\* Insulated and stored.

† From LG terminal of plugs—insulate and store.