

## SERVICE

### 2638- AND 2639-TYPE TELEPHONE SETS

### CONNECTIONS AND MAINTENANCE

#### 1. GENERAL

**1.01** This section contains information for 2638-type, (18-button) and 2639-type (30-button) CALL DIRECTOR® telephone sets equipped with 12-button TOUCH-TONE® dial and headset jacks. These sets are used with station line concentrators.

**1.02** This section is reissued to:

- Show 2638CAM and 2639DAM telephone sets MD
- Add the 2638CAMS1 and 2639DAMS1 telephone sets, new Fig. 3
- Update Notes (Fig. 4 and 5)
- Add information on the new 840364376 polarity guard and instruction sheet which comes in the D-181006 Kit of Parts.

**1.03** These sets are not intended for use with 3-type (MD) or 4A speakerphone systems or 1A key telephone systems (KTS).

**1.04** ♦The new S coded telephone sets are similar to the previous type sets, except they are equipped with a new line switch which breaks both the tip and ring side of the line. Previous type sets only broke the ring side of the line.♦

#### 2. CONNECTIONS

**2.01** These sets are factory-wired for use with 1A1, 1A2, 6A, or ♦6B♦ KTS. Refer to Section 518-310-405 for connections using 235- or 236-type key telephone units (KTU).

**2.02** A 235A (MD) or 235D KTU is associated with each 2638-type telephone set. A 236A (MD) or 236B KTU is associated with each 2639-type

telephone set. Because of the single common talking pair and control lead patterns used in these sets, a line concentrator unit must be associated with each telephone set installed and cannot be shared even on a bridged station basis.

**2.03** See SD-69499-01 (key telephone system, 6A, ♦6B,♦1A1, and 1A2 station line concentrators) and Section ♦518-310-405♦ for connection to station line concentrators using 235- and 236-type key telephone units.

**2.04** When 400-type KTU's are used as line circuits, a 235B or 236B KTU must be used or a 235A (MD) or 236A (MD) KTU modified as shown in Section ♦518-310-405.♦

**2.05** The 2638CAM, 2638CAMS1 and 2639DAM, 2639DAMS1 telephone sets are equipped with a 241-type amplifier.

**2.06** The 2638- and 2639-type sets that are provided with D50AH (MD) or D80D (MD) mounting cords require contact strip assemblies on the 635-type keys. These sets are normally provided with a 635A5C key (5-line pickup and hold) in the first module. If desired, the 635A5C key can be replaced with a 625AD5C key (4-line pickup, cutoff, and hold). In this case the contact strip assemblies for the 635AD5C key (840151039 and 840151047) are furnished with the key.

**Note:** Contact strips are not required with sets equipped with D50BD or D80E mounting cords. A and A1 are common to all pickup buttons through internal mounting cord wiring.

**2.07** Because of the physical arrangement of the 635-type key, the contact strips do not extend to the chaining switch. This requires additional A1 leads to each module (except the last) to provide A lead control.

#### NOTICE

Not for use or disclosure outside the  
Bell System except under written agreement

**2.08** The D50AH (MD) and D80D (MD) mounting cords are replaced by D50BD and D80E, respectively.

**2.09** Mounting cords of these CALL DIRECTOR sets terminate in individual plugs connected to the rear of the keys. This permits rearrangement of line appearances either in the set or at the key equipment distribution point. Current sets are equipped with the satin silver (-87) mounting cord.

**2.10** All line key positions are convertible from pickup (locking) to signaling (nonlocking). To convert a key position, remove the 812857738 (P-28E773) screw detail from key position involved and make the necessary wiring changes as shown in Table B or C.



*Some spade-tipped conductors or mounting cord leads are insulated with tubing which, when used, should be cut off with electrician scissors or diagonal pliers. Other conductors are insulated with stiff plastic pockets. Pinch open the mouth of the pocket to release the spade tips.*

**2.11** The 819040338 (P-90D033) Printed Wiring Board Assembly used to provide a station busy lamp circuit for 2638- and 2639-type telephone sets is intended to mount in the 235- or 236-type line concentrator key telephone unit associated with these sets. Connections to the telephone set are through the TA lead (Fig. 4 and 5). For connections to the printed wiring board assembly, see Section 518-310-405 on station line concentrators or refer to SD-69580-01.

**2.12** A KS-8109L2 or KS-20419L1 buzzer may be installed when a second audible signal is required. Use (O-R) and (R-O) mounting cord conductors from (BL) binder stored in first module for connections. Current sets are equipped with a KS-20419L1 (10 volt ac only) buzzer connected as shown.

**2.13** When required, these sets may be equipped with a polarity guard. Polarity guards should be installed only when specified by local instructions for end-to-end signaling purposes when battery and ground reversals are encountered. A guard assembly must be separately ordered and connected as shown in Table A.

**3. MAINTENANCE**

**3.01** Maintenance information for these sets is found in Section 502-600-100 entitled 630, 1630, and 2630 Telephone Sets, Common Installation and Maintenance.

**3.02** Individual components such as dials, keys, ringer, etc., are covered in sections pertaining to the particular item.

**3.03** *Do not use solvents to clean plastic parts of these sets.* Use a damp cloth only. If discolored, replace part.

**TABLE A**  
840364376 OR 819041971 (P-90D197) (MD) POLARITY GUARD CONNECTIONS (Note)

| LEAD           | COLOR  | REMOVE FROM | CONNECT TO |
|----------------|--------|-------------|------------|
| Line Switch    | (W)    | C*          | S†         |
| Headset Jack   | (BK-S) |             |            |
| Dial           | (BK)   | RR*         | T†         |
| Polarity Guard | (W)    |             | C*         |
|                | (G)    |             | RR*        |

\* Network terminal

† Polarity guard terminal

**Note:** The D-181006 Kit of Parts (ordered separately) includes the 840364376 polarity guard and instruction sheet.

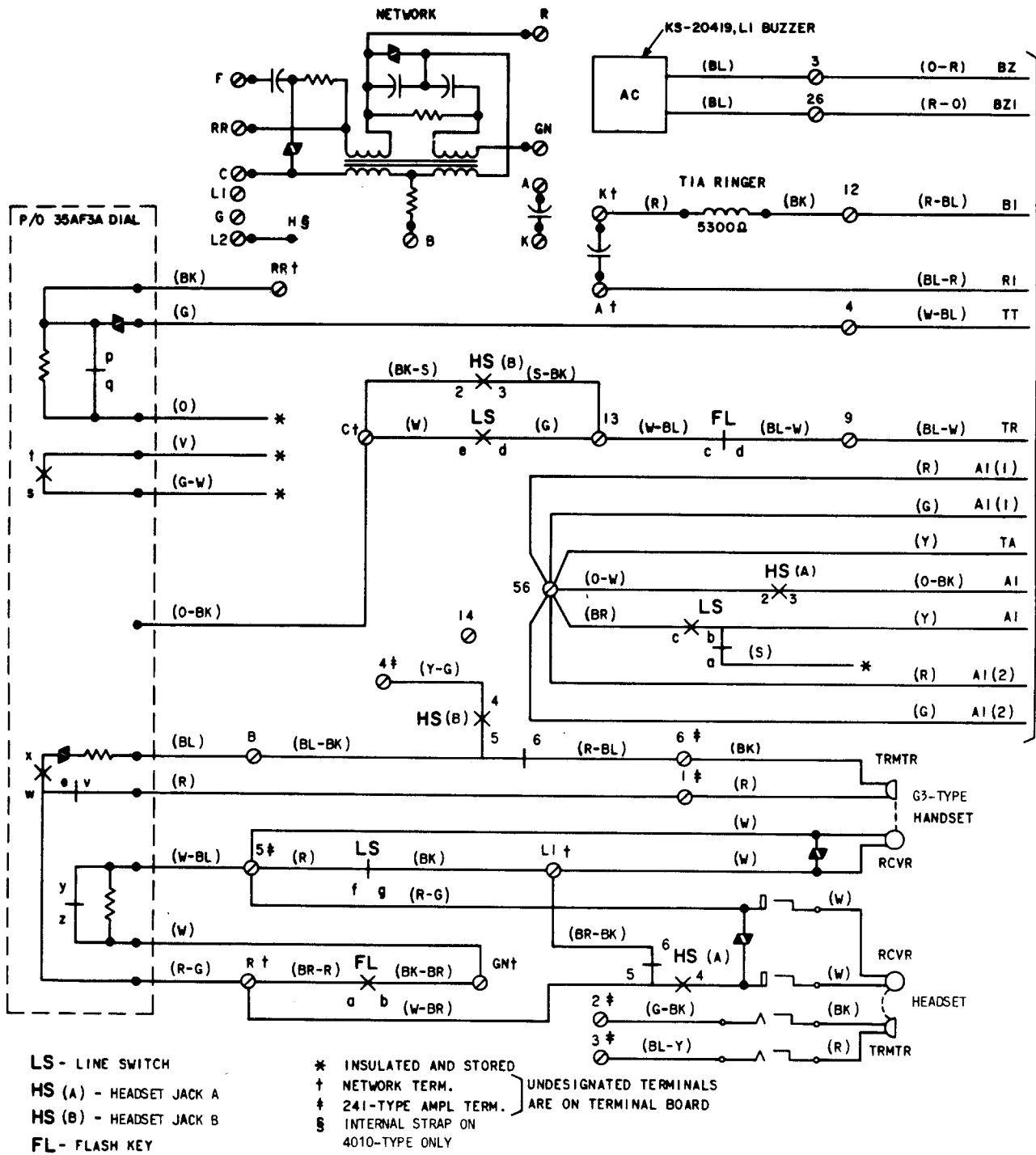

TO FIG. 3 OR 4

Fig. 1—2638CA and 2639DA Telephone Set, Connections

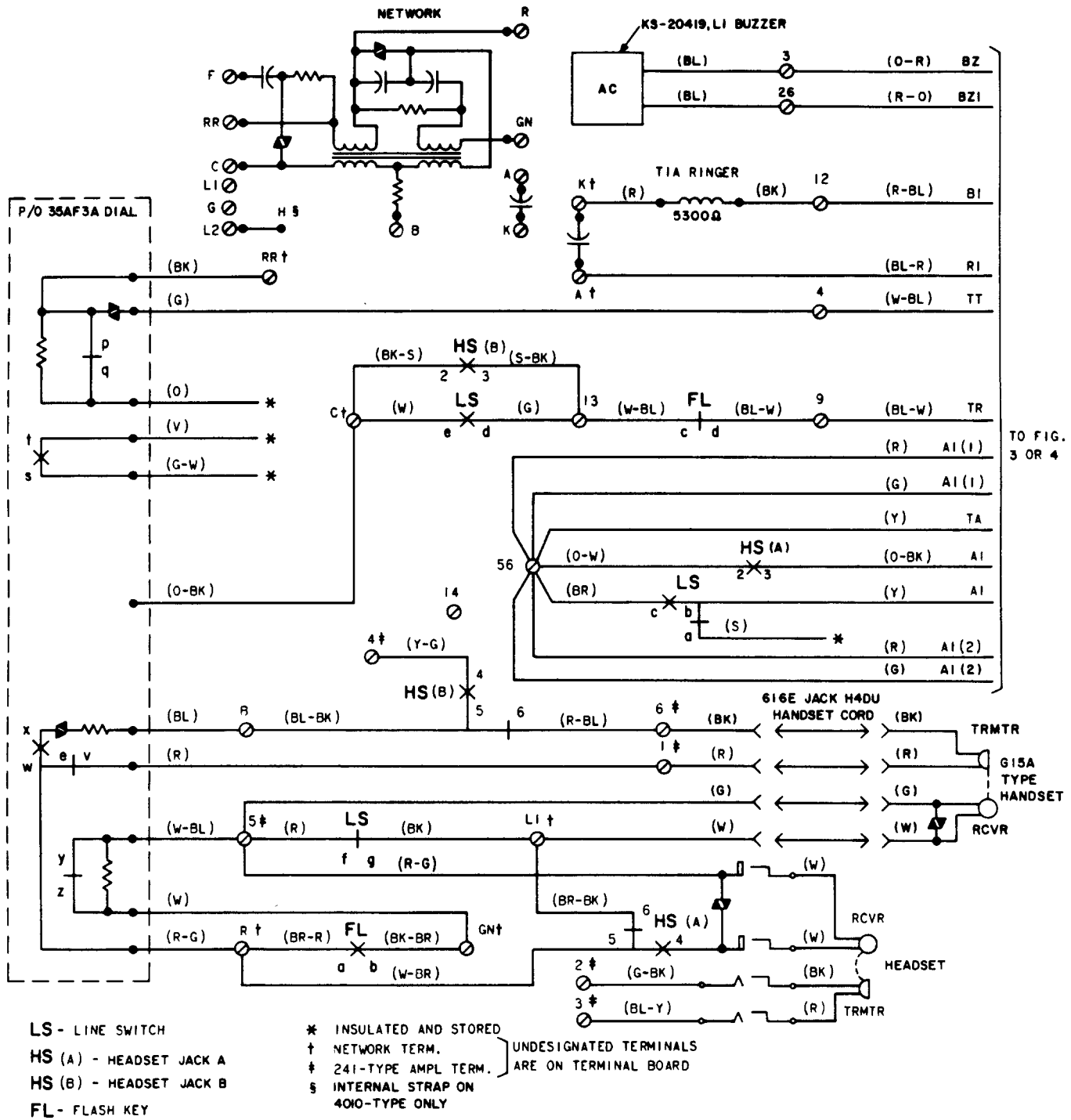

TO FIG. 3 OR 4

Fig. 2—2638CAM and 2639DAM Telephone Set, Connections

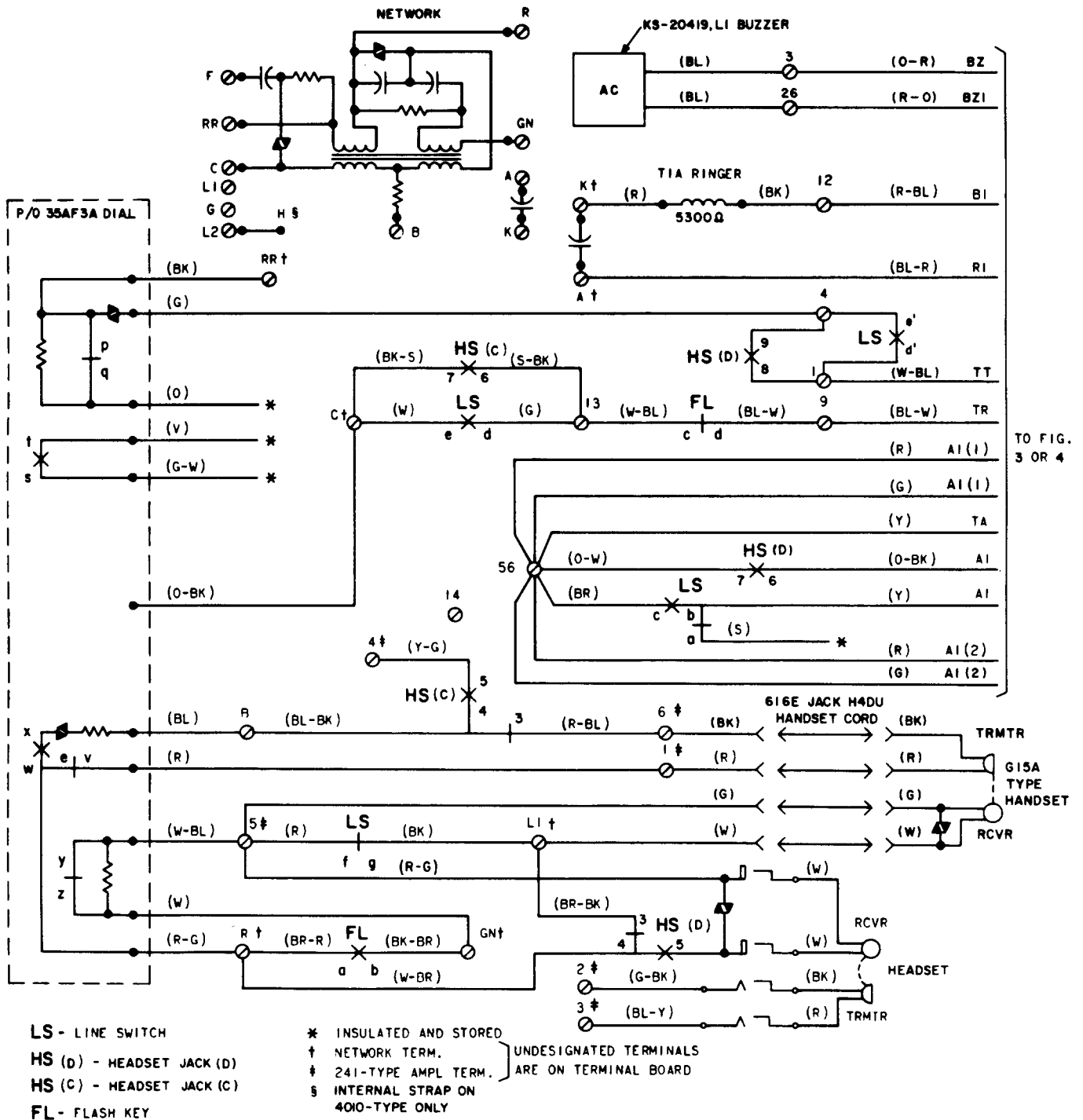

TO FIG. 3 OR 4

Fig. 3—2638CAMS1 and 2639DAMS1 Telephone Set, Connections

NOTES FOR FIGURES 4 AND 5:

1. THE 635AD5C KEY IS SUPPLIED WITH AN ADAPTER IN THE CUTOFF KEY POSITION. IN SETS EQUIPPED WITH D50AH (MD) OR D80D (MD) MOUNTING CORD, CONTACT STRIP ASSEMBLIES 840151039 AND 840151047 FURNISHED WITH THE 635AD5C KEY REPLACE THE 840151120 AND 840151138 ASSEMBLIES USED WITH THE 635A5C KEY. THE SLATE MOUNTING CORD PLUG CONNECTS TO THE ADAPTER. BALANCE OF PLUGS CONNECT DIRECTLY TO KEY.
2. IF A 635AD5C KEY IS ADDED IN THE FIELD, FOR RINGER CUTOFF TERMINATE THE (BL-Y) ADAPTER LEAD AS INDICATED IN NOTE 6 AND REMOVE (R) SLATE PLUG LEAD FROM TERMINAL 22, INSULATE AND STORE.
3. IF THE HOLD POSITION LAMP (6TH) 635A5C OR 635AD5C KEY IN THE FIRST MODULE IS USED FOR A VISUAL SIGNAL. REMOVE (Y-G) LAMP GROUND LEAD FROM STORED LOCATION IN FIRST MODULE AND CONNECT TO TERMINAL 22. CONNECT THE (G-Y) LAMP LEAD FROM THE PINK PLUG AND THE (R-G) LEAD FROM THE MOUNTING CORD USING A SPARE TERMINAL OR D-161488 CONNECTOR.
4. IN SETS EQUIPPED WITH A658A KEY, THE (G) CONTACT STRIP OR PLUG STRAP LEAD IS TERMINATED ON TERMINAL 10 AND (R) ON 11. IF A 658A KEY IS ADDED IN THE FIELD, LEADS MUST BE MOVED FROM PRECEDING MODULE CHAINING CIRCUIT TO TERMINALS 10 AND 11. PROVISIONS ARE MADE FOR MECHANICALLY STORING THE LIGHT BEIGE PLUG ON THE 658A KEY. NO ELECTRICAL CONNECTION IS MADE.
5. WHEN THE 658A KEY IS REQUIRED AS A DUAL PURPOSE KEY, REMOVE STRAP BETWEEN TERMINALS 10 AND 11. USE MTW CORD OF EQUIVALENT TO CONNECT TERMINAL 11 TO A GROUND OTHER THAN SIGNAL GROUND.
6. CUTOFF OF THE INTERNAL RINGER CAN BE PROVIDED USING THE 635AD5C KEY IN THE FIRST MODULE. TRANSFER B1 (R-BL) LEAD FROM TERMINAL 12 AND (BL-Y) ADAPTER LEAD TO SPARE TERMINAL OR D-161488 CONNECTOR. REMOVE (W-G) LEAD (SLATE PLUG) FROM TERMINAL 57 AND CONNECT TO 12.
7. WHEN 635AD5C KEY IS USED IN THE FIRST MODULE TO PROVIDE CUTOFF, SWITCHING, OR TRANSFER FEATURES, MOVE (W-BR) SLATE PLUG LEAD FROM TERM. 60 TO TERMINAL 11. THESE SERVICE FEATURES ARE PROVIDED BY AN AUXILIARY RELAY (229B KTU OR EQUIVALENT) SEPARATELY MOUNTED AND CONTROLLED BY THE CUTOFF KEY CONTACTS THROUGH LG5, C, S, S1 LEAD.
8. CONTROL LEADS CA TO CJ ARE CONNECTED TO TERMINALS 57 TO 65. THESE TERMINALS APPEAR ON MORE THAN ONE OF THE MODULE SHEETS OF FIG. 3 AND 4 BUT ARE THE SAME TERMINAL.
9. THESE CONTACT STRIPS ARE REQUIRED WHEN TELEPHONE SET IS EQUIPPED WITH THE D50AH (MD) OR D80D (MD) MOUNTING CORD. THESE CONTACT STRIPS SHOULD NOT BE USED WHEN TELEPHONE SET IS EQUIPPED WITH THE D50BD OR D80E MOUNTING CORD.
10. THE CURRENT 2 CODED TELEPHONE SETS HAVE THE (G-R) LEAD INSULATED AND STORED.

- \*- INSULATED AND STORED
- †- DEAD DRESSED
- ‡- LEAD COLOR IN D50BD MTG CORD
- §- LEAD COLOR IN D80E MTG CORD

Fig. 4—♦2638-Type Telephone Set Module and Connector Cable Arrangements (Notes)♦

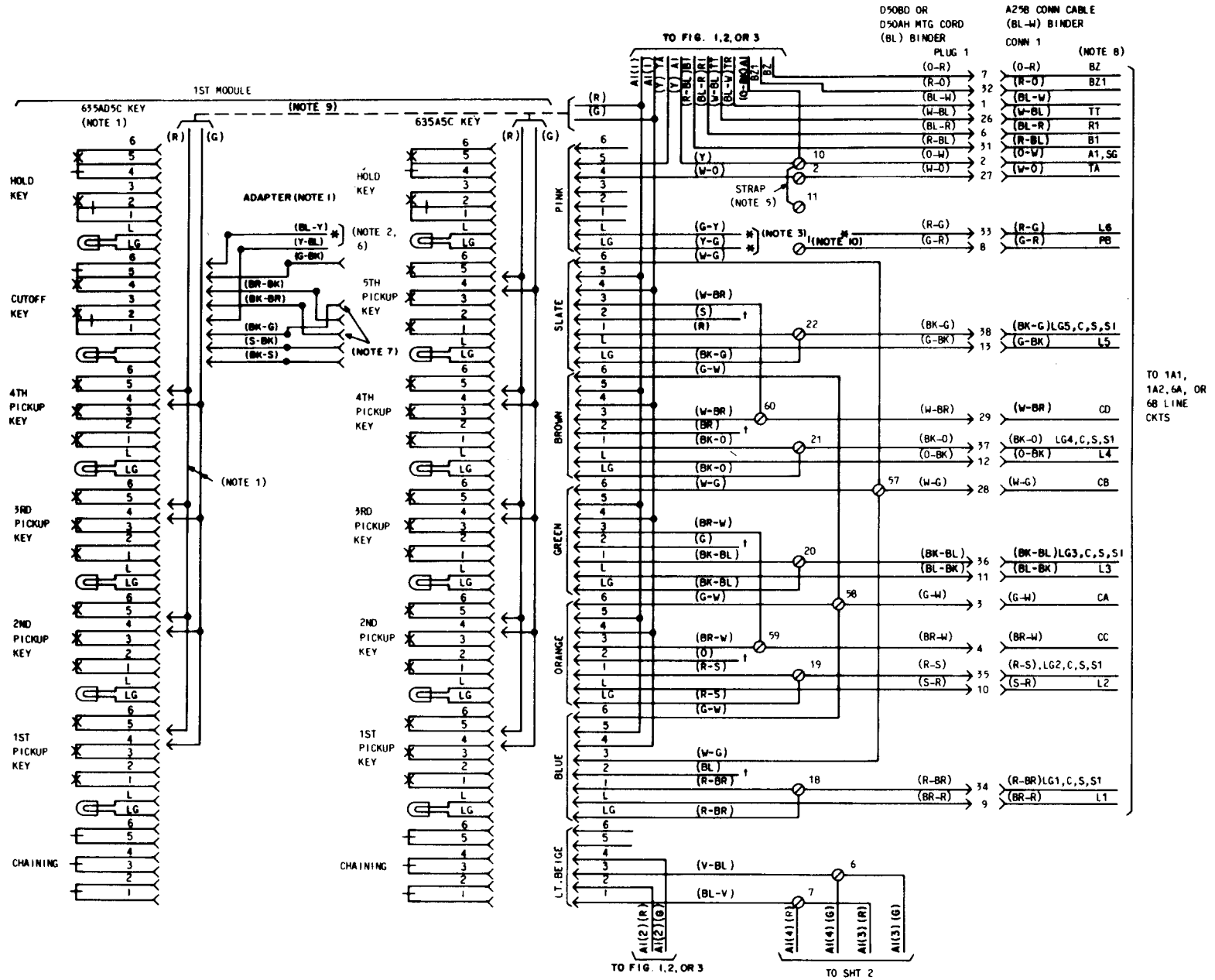

Fig. 4—2638-Type Telephone Set Module and Connector Cable Arrangements (Sheet 1 of 3)

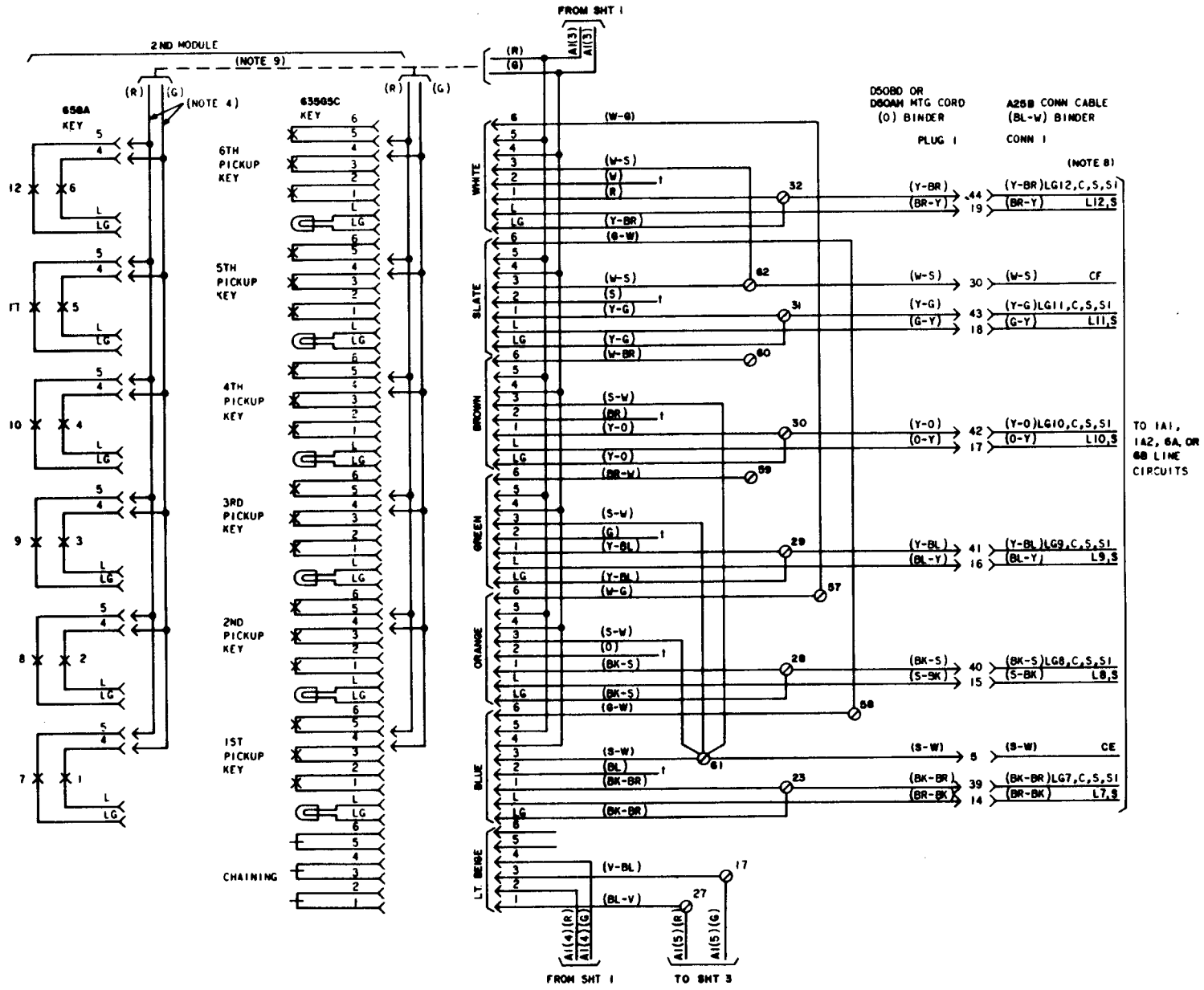

Fig. 4—2638-Type Telephone Set Module and Connector Cable Arrangements (Sheet 2 of 3)



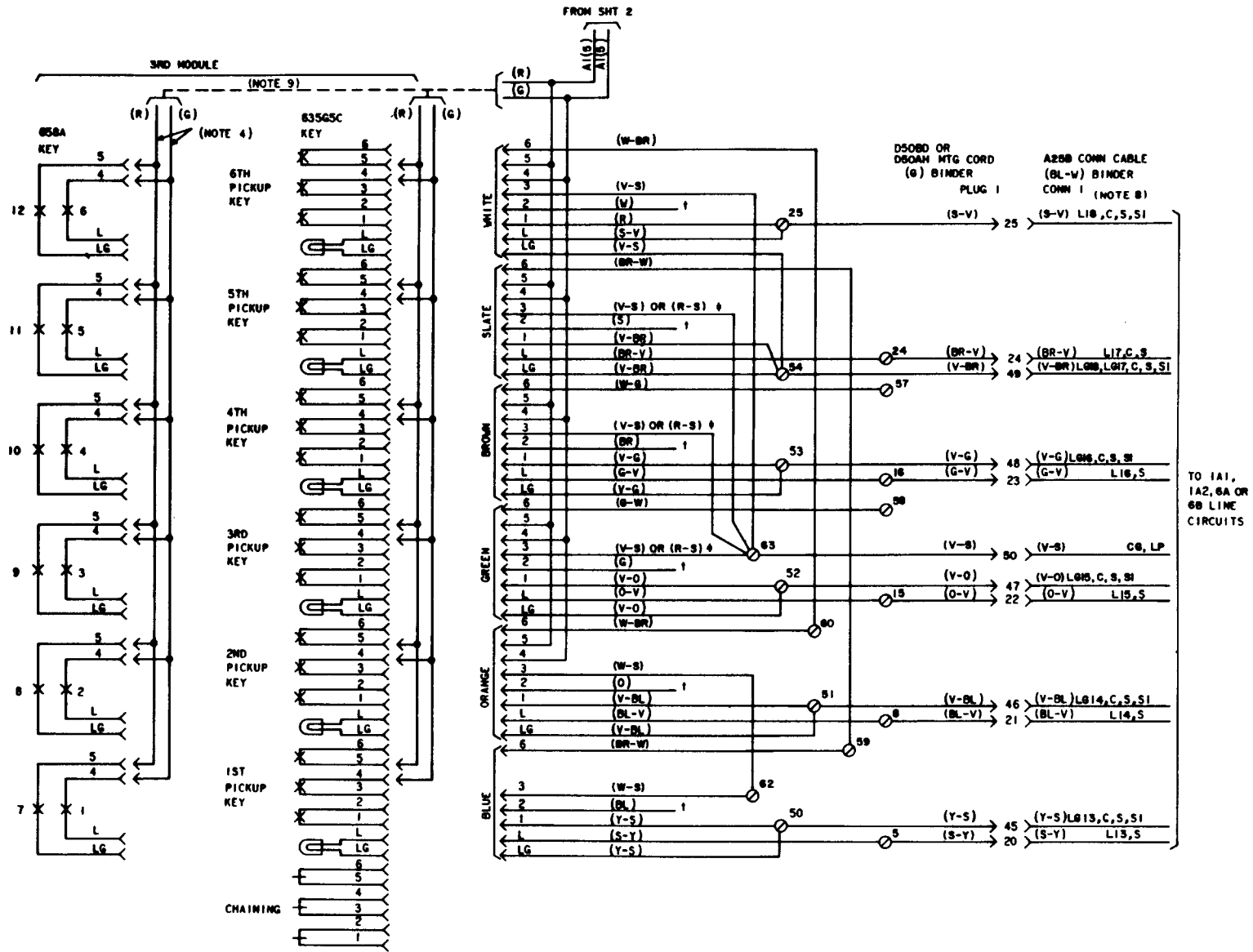

Fig. 4—2638-Type Telephone Set Module and Connector Cable Arrangements (Sheet 3 of 3)

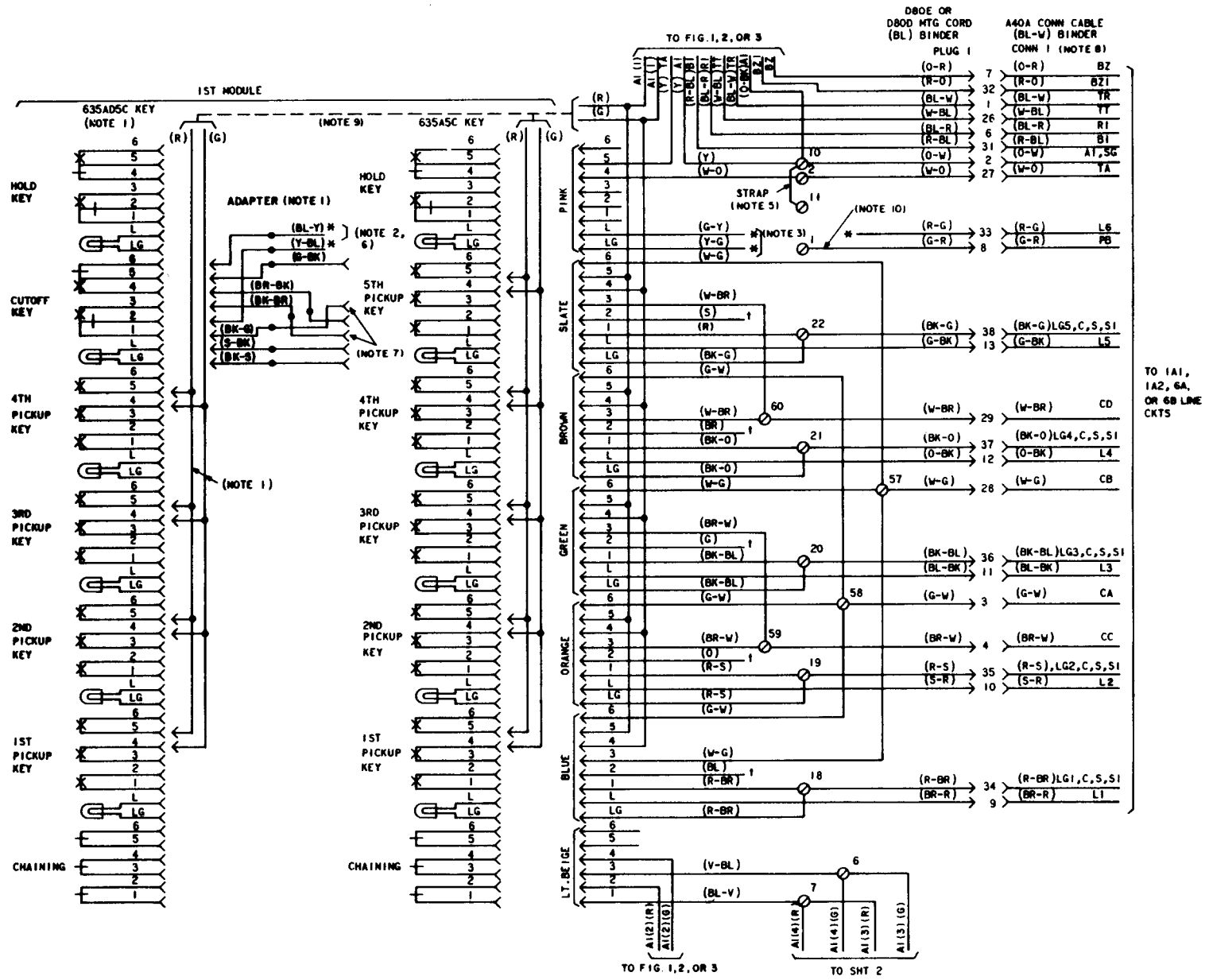

Fig. 5—2639-Type Telephone Set Module and Connector Cable Arrangements (Sheet 1 of 5)

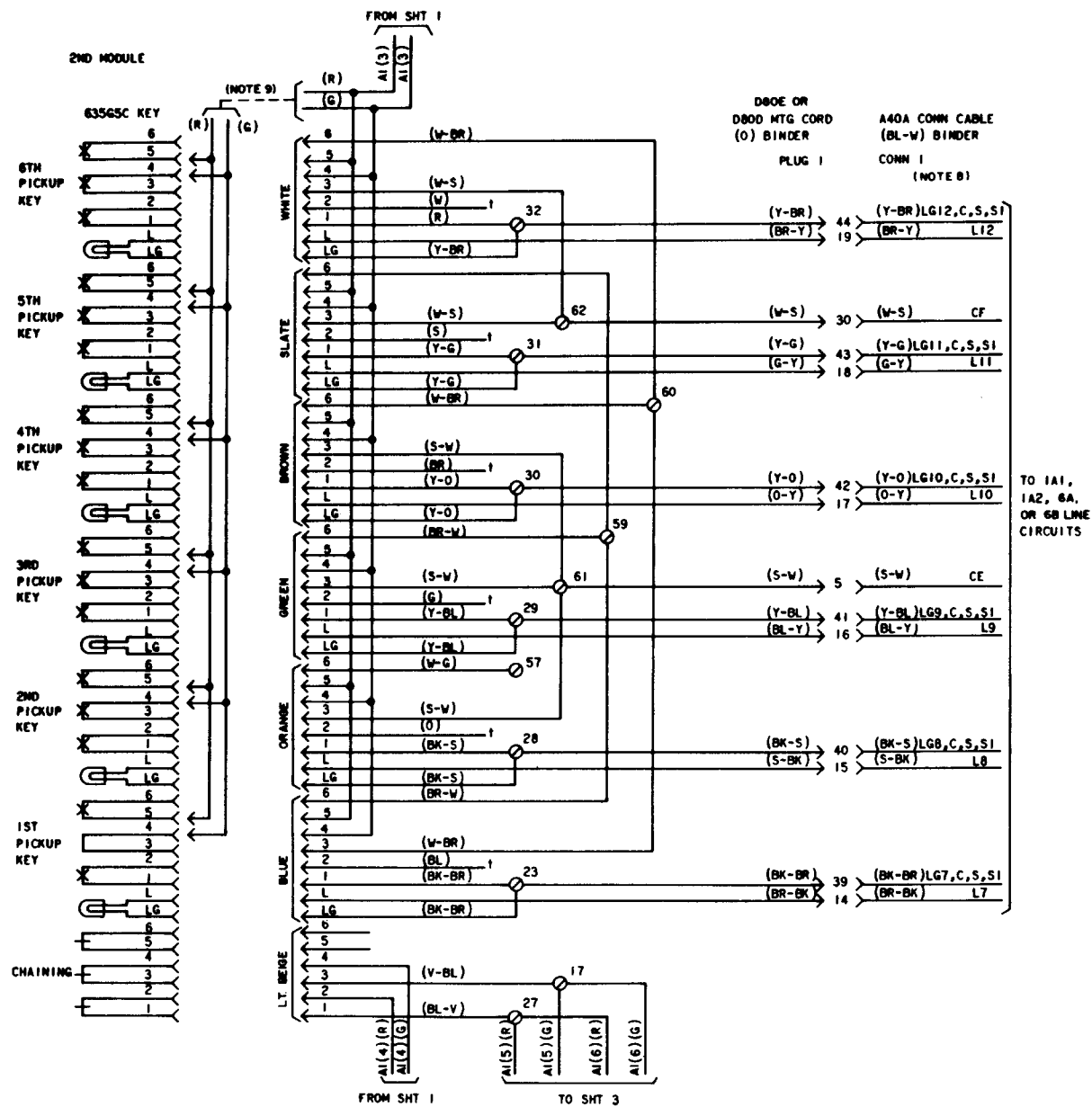

Fig. 5—2639-Type Telephone Set Module and Connector Cable Arrangements (Sheet 2 of 5)

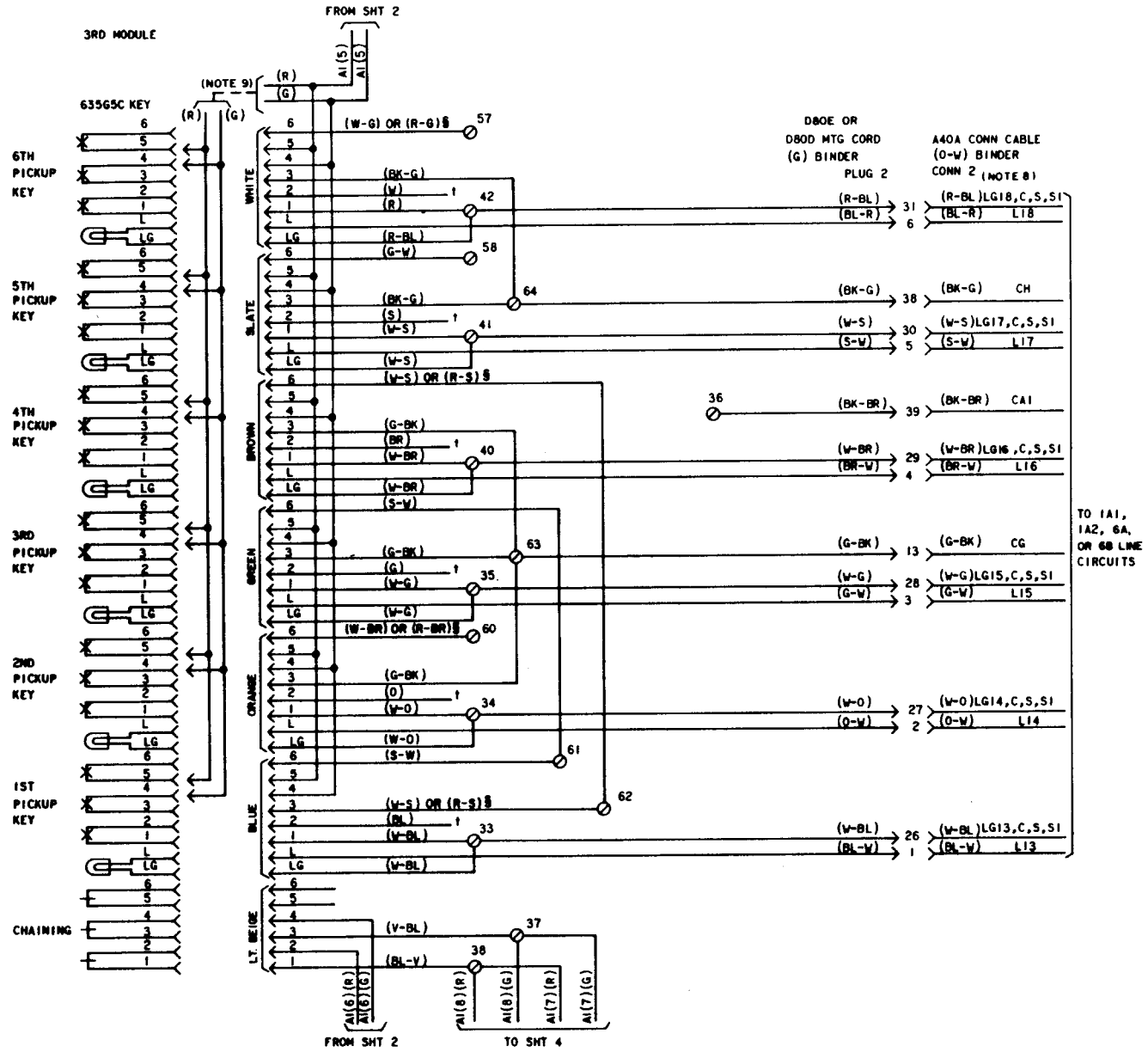

Fig. 5—2639-Type Telephone Set Module and Connector Cable Arrangements (Sheet 3 of 5)

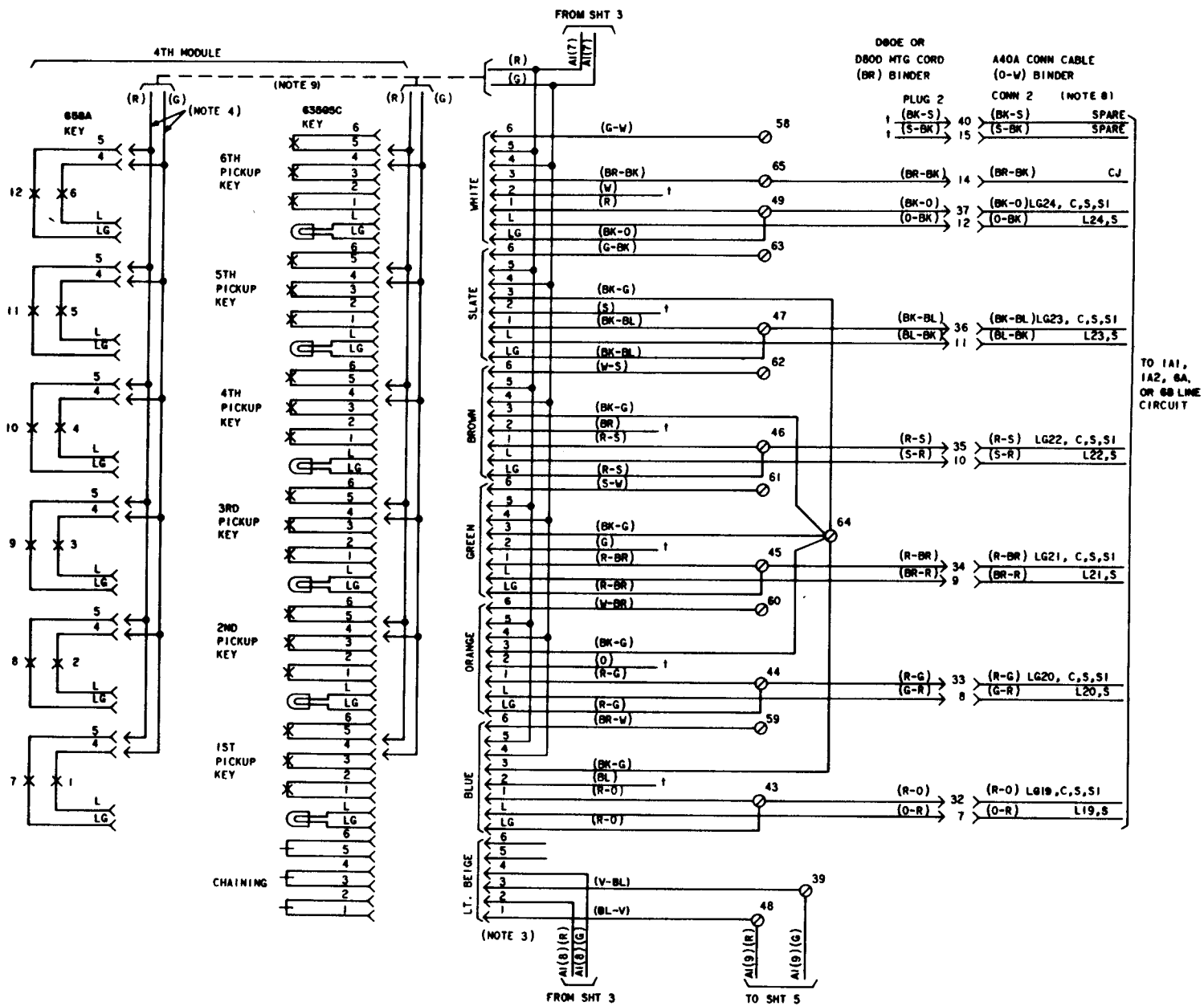

Fig. 5—2639-Type Telephone Set Module and Connector Cable Arrangements (Sheet 4 of 5)†

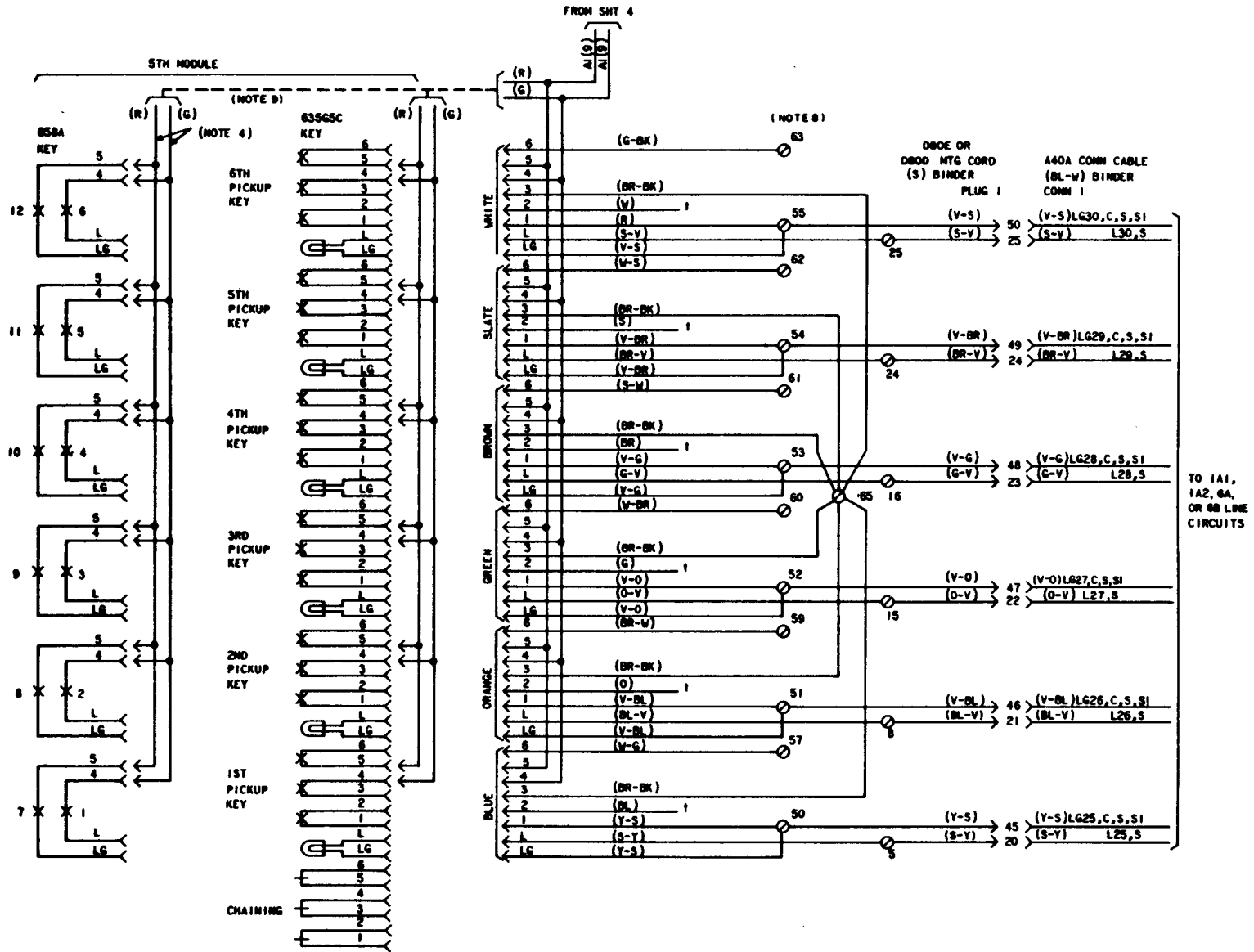

Fig. 5—2639-Type Telephone Set Module and Connector Cable Arrangements (Sheet 5 of 5)

**TABLE B**

**PICKUP-SIGNAL KEY CONVERSION—3RD MODULE, 2638-TYPE TELEPHONE SET**

| NO. OF SIGNAL KEYS | KEY PLUG LEADS |     |      |     |            |      |      |     |            |     |     |             |            |     |     |             |            |      |      |             |            |     |      |     |
|--------------------|----------------|-----|------|-----|------------|------|------|-----|------------|-----|-----|-------------|------------|-----|-----|-------------|------------|------|------|-------------|------------|-----|------|-----|
|                    | 1ST PICKUP     |     |      |     | 2ND PICKUP |      |      |     | 3RD PICKUP |     |     |             | 4TH PICKUP |     |     |             | 5TH PICKUP |      |      |             | 6TH PICKUP |     |      |     |
|                    | BL             | Y-S | BR-W | W-S | O          | V-BL | W-BR | W-S | G          | V-O | G-W | V-S<br>R-S† | BR         | V-G | W-G | V-S<br>R-S† | S          | V-BR | BR-W | V-S<br>R-S† | W          | V-S | W-BR | V-S |
| 1                  | *              | 50  | 59   | 62  | *          | 51   | 60   | 62  | *          | 52  | 58  | 63          | *          | 53  | 57  | 63          | *          | 54   | 59   | 63          | 10         | †   | *    | *   |
| 2                  | *              | 50  | 59   | 62  | *          | 51   | 60   | 62  | *          | 52  | 58  | 63          | *          | 53  | 57  | 63          | 10         | †    | *    | *           | 10         | †   | *    | *   |
| 3                  | *              | 50  | 59   | 62  | *          | 51   | 60   | 62  | *          | 52  | 58  | 63          | 10         | †   | *   | *           | 10         | †    | *    | *           | 10         | †   | *    | *   |
| 4                  | *              | 50  | 59   | 62  | *          | 51   | 60   | 62  | 10         | †   | *   | *           | 10         | †   | *   | *           | 10         | †    | *    | *           | 10         | †   | *    | *   |
| 5                  | *              | 50  | 59   | 62  | 10         | †    | *    | *   | 10         | †   | *   | *           | 10         | †   | *   | *           | 10         | †    | *    | *           | 10         | †   | *    | *   |
| 6                  | 10             | †   | *    | *   | 10         | †    | *    | *   | 10         | †   | *   | *           | 10         | †   | *   | *           | 10         | †    | *    | *           | 10         | †   | *    | *   |

\* Insulated and stored.

† From LG terminal of plugs — insulate and store.

‡ Lead color in D50BD mounting cord.

**TABLE C**

**PICKUP-SIGNAL KEY CONVERSION—5TH MODULE, 2639-TYPE TELEPHONE SET**

| NO. OF SIGNAL KEYS | KEY PLUG LEADS |     |     |       |            |      |      |       |            |     |      |       |            |     |     |       |            |      |     |       |            |     |      |       |
|--------------------|----------------|-----|-----|-------|------------|------|------|-------|------------|-----|------|-------|------------|-----|-----|-------|------------|------|-----|-------|------------|-----|------|-------|
|                    | 1ST PICKUP     |     |     |       | 2ND PICKUP |      |      |       | 3RD PICKUP |     |      |       | 4TH PICKUP |     |     |       | 5TH PICKUP |      |     |       | 6TH PICKUP |     |      |       |
|                    | BL             | Y-S | W-G | BR-BK | O          | V-BL | BR-W | BR-BK | G          | V-O | W-BR | BR-BK | BR         | V-G | S-W | BR-BK | S          | V-BR | W-S | BR-BK | W          | V-S | G-BK | BR-BK |
| 1                  | *              | 50  | 57  | 65    | *          | 51   | 59   | 65    | *          | 52  | 60   | 65    | *          | 53  | 61  | 65    | *          | 54   | 62  | 65    | 10         | †   | *    | *     |
| 2                  | *              | 50  | 57  | 65    | *          | 51   | 59   | 65    | *          | 52  | 60   | 65    | *          | 53  | 61  | 65    | 10         | †    | *   | *     | 10         | †   | *    | *     |
| 3                  | *              | 50  | 57  | 65    | *          | 51   | 59   | 65    | *          | 52  | 60   | 65    | 10         | †   | *   | *     | 10         | †    | *   | *     | 10         | †   | *    | *     |
| 4                  | *              | 50  | 57  | 65    | *          | 51   | 59   | 65    | 10         | †   | *    | *     | 10         | †   | *   | *     | 10         | †    | *   | *     | 10         | †   | *    | *     |
| 5                  | *              | 50  | 57  | 65    | 10         | †    | *    | *     | 10         | †   | *    | *     | 10         | †   | *   | *     | 10         | †    | *   | *     | 10         | †   | *    | *     |
| 6                  | 10             | †   | *   | *     | 10         | †    | *    | *     | 10         | †   | *    | *     | 10         | †   | *   | *     | 10         | †    | *   | *     | 10         | †   | *    | *     |

\* Insulated and stored.

† From LG terminal of plugs — insulate and store.