

## TELEPHONE SETS—630 AND 1630 SERIES IDENTIFICATION AND ASSEMBLY OF PARTS

### 1. GENERAL

**1.01** This section identifies the various codes of 630 and 1630 series telephone sets, lists component parts, and shows parts assembled. It may be used to select particular telephone set needed to meet various service requirements.

**1.02** This section is reissued to incorporate information in the identification, assembly, selection, and maintenance sections of 630 and 1630 series telephone sets. It also includes information on the 600 and 601 series telephone sets which are rated Manufacture Discontinued (MD).

**1.03** Sets which have been modified by use of a mounting cord other than that specified will be marked in yellow ink in the area in front of the ringer. For example: E W D200F mtg. cord.

### 2. IDENTIFICATION

**2.01** These are Call Director, multibutton telephone sets arranged to work with 1A, 1A1, 1A2, and 6A key telephone system circuits.

**2.02** The 630 series set is equipped with a rotary dial and the 1630 series set with a TOUCH-TONE dial (Fig. 1 and 2).

**2.03** These sets accommodate three to five plug-in modular units. Sets which accommodate three modular units are 18-button sets. Sets which accommodate five modular units are 30-button sets.

**2.04** These sets are also manufactured with jacks for optional use with 52A or 53A head telephone sets or G3AR hand sets.

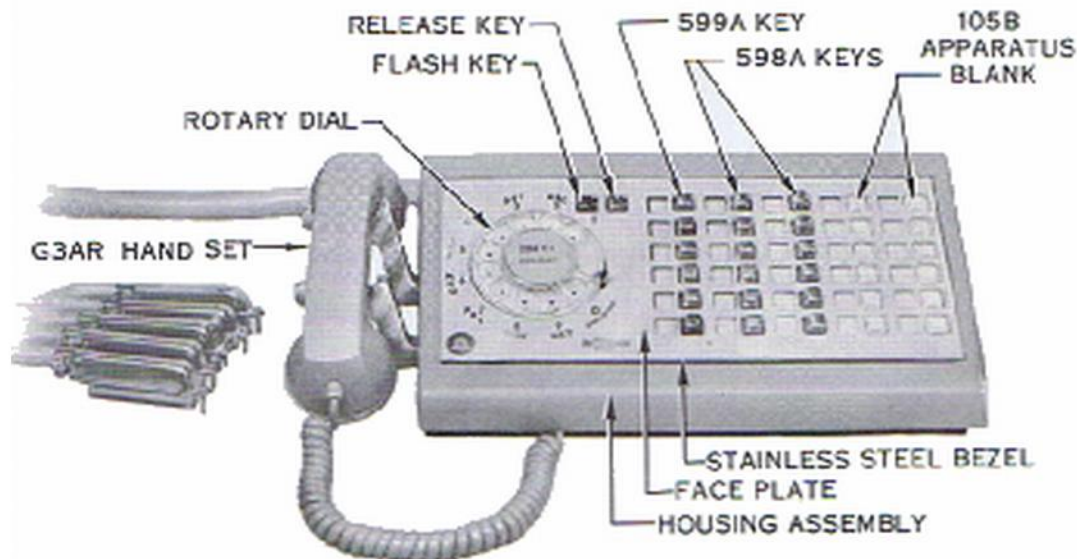

Fig. 1 — 637-Type Telephone Set with Jacks (All Purpose)



Fig. 2 - 1630-Type Telephone Set

2.05 These sets can be divided into three general types:

- (1) All purpose (Fig. 1 and 2).
- (2) Limited use (Fig. 3 and 4).
- (3) Concentrator (Fig. 5 and 6).

2.06 Limited use sets may be used with 1A1, 1A2, and 6A key telephone systems only. These sets are not available with jacks for headset operation.

2.07 Concentrator type sets are used with 1A1, 1A2, or 6A key telephone systems only. A separate KTU concentrator is required with each set. A 235A KTU is required for the 18-button set and a 236A KTU for the 30-button set. These sets are intended for use primarily at installations where congested or restricted diameter conduit systems limit the size of cables which can be run to the station. These sets are available with and without headset jacks.

2.08 The 630 and 1630 series telephone sets are available in colors listed in Table A.

2.09 Table B lists set code number and specific information.

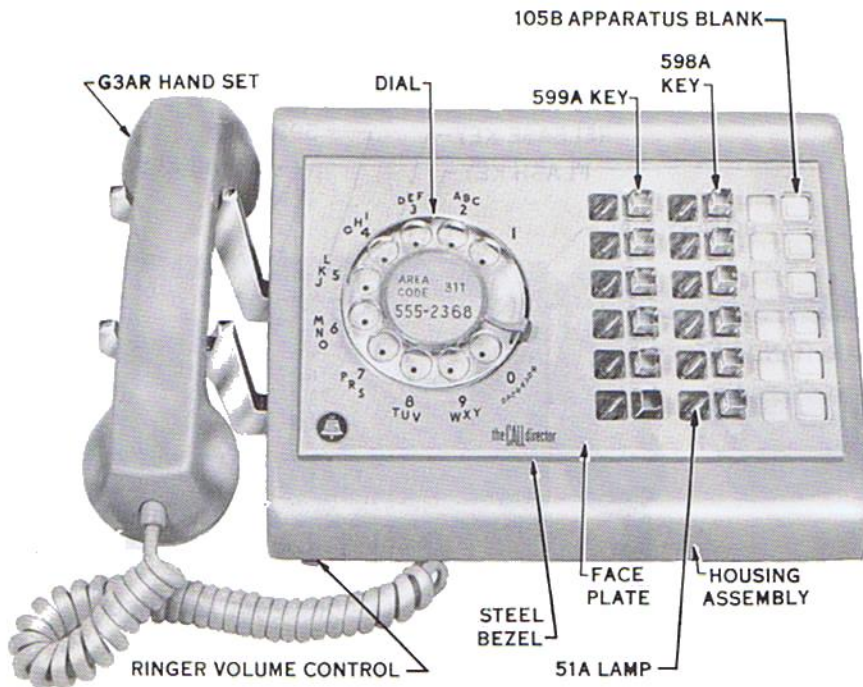

Fig. 3 - 630-Type Telephone Set

**TABLE A****COLORS**

Promoted*		Nonpromoted†	
Moss Green	(-51)	Black	(- 3)
White	(-58)	Yellow	(-56)
Light Beige	(-60)	Pink	(-59)
Light Gray	(-61)	Aqua Blue	(-62)
		Turquoise	(-64)

\* Indicates sets manufactured in quantity.

† Indicates sets manufactured in limited quantity; obtainable on special order only.

### 3. COMPONENTS

**3.01** The talk, dial, and ringer circuits in these Call Director sets are similar to the circuits employed in the 500 and 1500 series multibutton sets.

**3.02** The Call Director sets arranged for use with an operator head telephone set or a plug-ended handset require a flash and release key assembly, two jacks, and a transistorized amplifier. These components are in addition to those common to all of these sets.

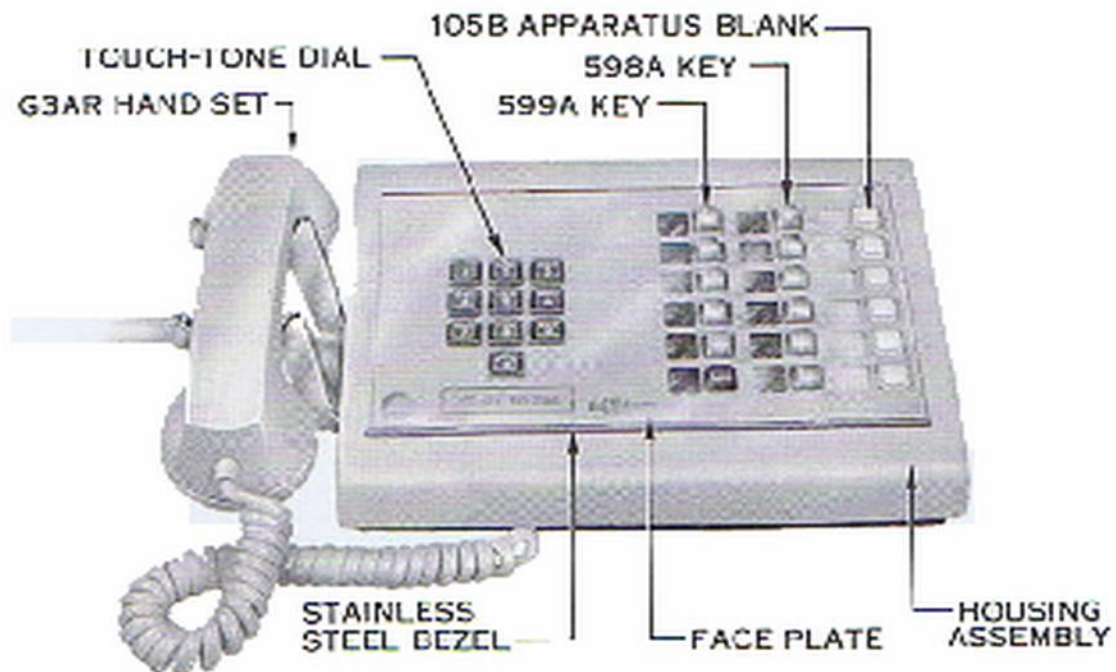

**Fig. 4 – 1632-Type Telephone Set without Jacks (Limited Use)**



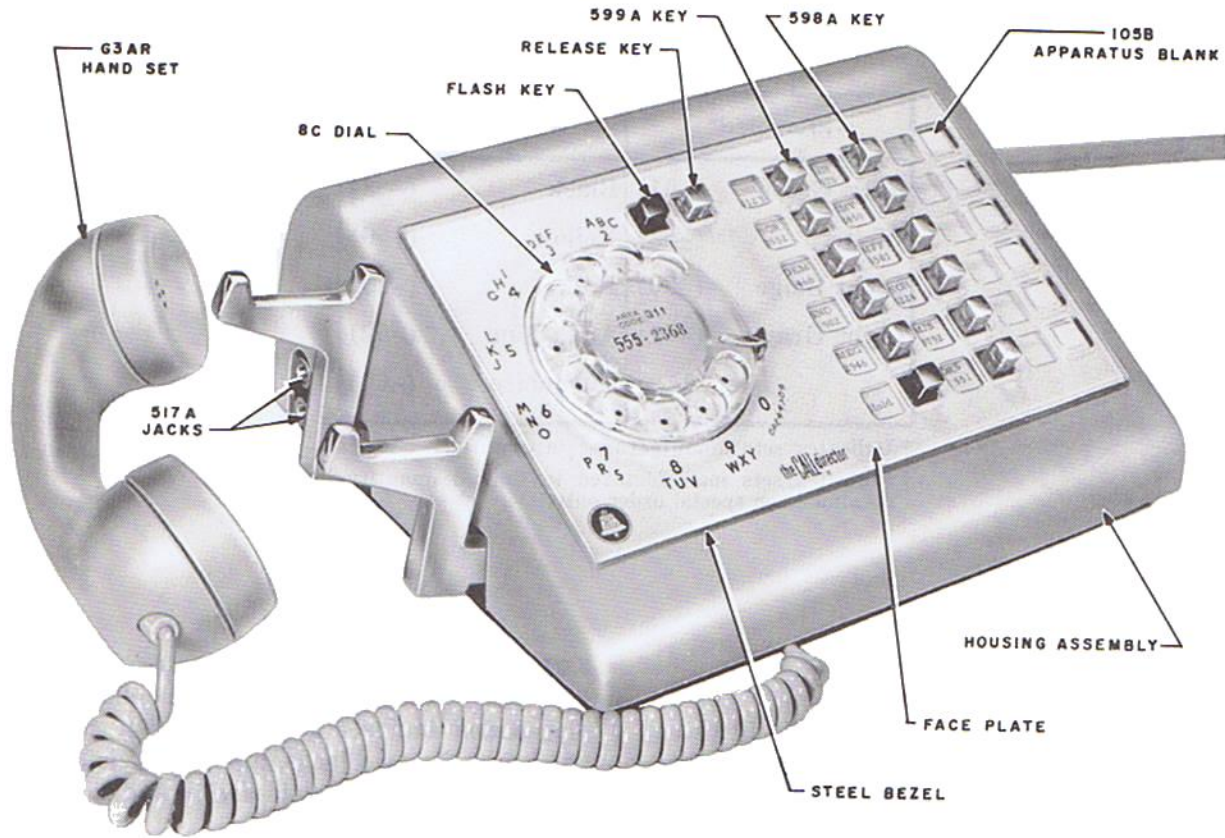

Fig. 5 — 638-Type Telephone Set

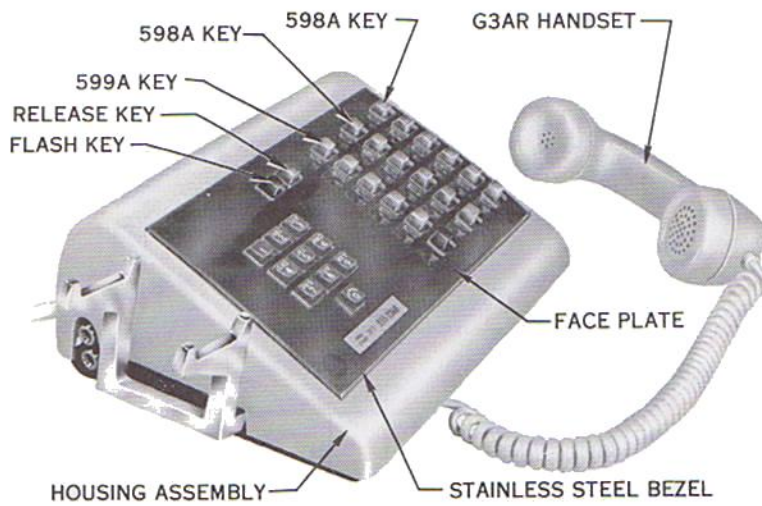

Fig. 6 — 1638-Type Telephone Set with Jacks (Concentrator Use)



Fig. 7 – Mounting Cord and Connector Cable



Fig. 8 – Mounting Cord and Connector Cable, Mated

3.03 All sets are equipped with a bracket for mounting internal buzzers.

3.04 The mounting cords provided with these sets are available in set colors. These cords are plug-ended and mate with plug-ended connector cables (Fig. 7 and 8).

3.05 A stainless steel bezel provided with each set is used as a holder for the colored mat and faceplate. The components for each Call Director are shown by set code number in Tables C and D.

#### 4. **FACTORY OPTIONS**

4.01 The sets are factory wired for use with 1A1 or 1A2 key telephone systems. All 598- and/or 599-type key button positions are equipped with 51A lamps.

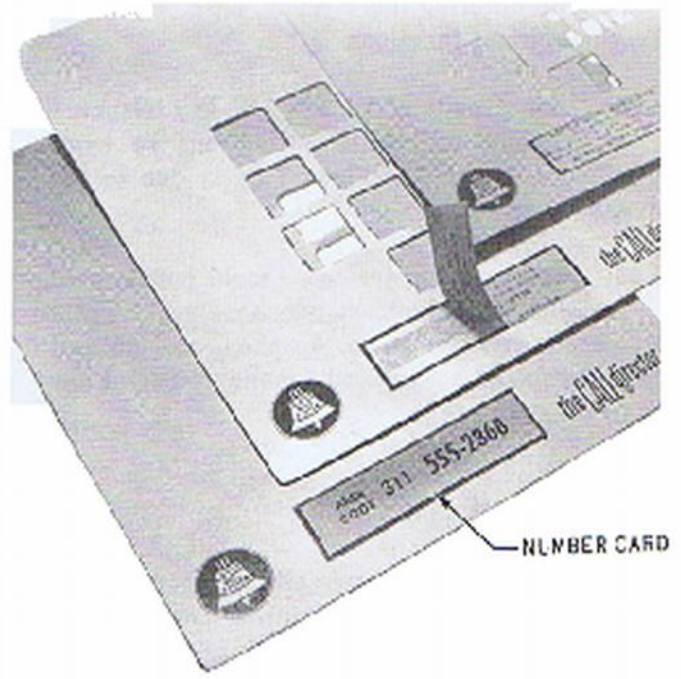

Fig. 9 – Colored Mats for Call Director



4.02 Designation strips and instruction pamphlets are shipped with each set. The sets are also furnished with two blocking rings and five colored mats (Fig. 9).

4.03 The concentrator type sets are shipped with insulating details. These are used when pickup keys are converted to signaling. Six of these details are provided in 18-button sets and twelve with 30-button sets.

5. **CONVERSIONS**

5.01 The 600 and 601 series telephone sets can be converted to 630 series telephone sets. For conversion procedure, see Table E.

5.02 Provision is made in the telephone sets currently being manufactured to allow rotary and TOUCH-TONE dials to be interchanged. If an interchange of dials is desired, it is necessary to change the faceplate assembly and add P-26E197 and P-26E198 dial adapter brackets to the rotary dial (Fig. 10).

6. **RESTRICTIONS**

6.01 It is not recommended to mix 1A2 line circuits with 1A1 or 1A line circuits on any set, due to differing line circuits, flash, wink, and time-out circuit functions.

6.02 Line circuits of 1A and 1A1 key telephone systems cannot be mixed on the same 6-button modular key unit. This is due to the modular key unit wiring.

6.03 Speakerphone systems should not be used with jack-equipped telephone sets. These sets are wired so that speakerphone and headset features should not be used simultaneously on the same set.

7. **FEATURES**

7.01 Sets which are currently being manufactured provide for mounting two KS-8100 type buzzers. The first buzzer can be mounted on the buzzer support bracket (Fig. 11), which is furnished equipped with the necessary mounting

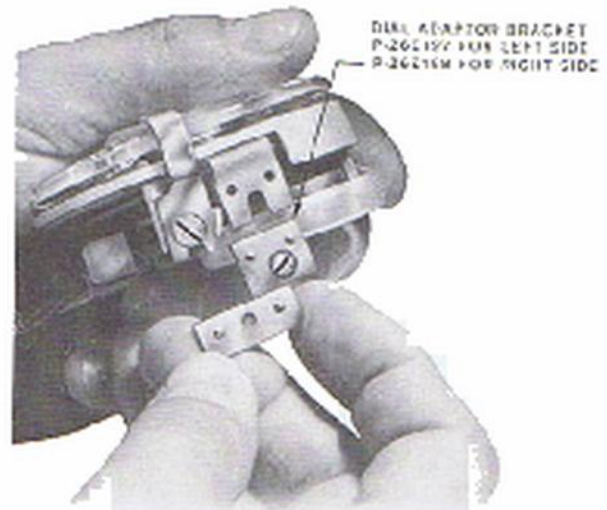

Fig. 10 — Placing Dial Adapter Brackets

details. This buzzer can be adjusted by removing the telephone set bezel and faceplate assembly without removing the housing.

7.02 A second KS-8100 type buzzer can be mounted beneath the dial mounting plate (Fig. 12). The dial mounting plate must be temporarily removed from the set to gain access to the two nylon screws and four insulating washers.

7.03 To install a 7-type buzzer, remove buzzer cover and buzzer support bracket. Mount buzzer in place of the removed buzzer support bracket.

8. **ASSEMBLY OF PARTS**

8.01 To remove bezel assembly (Fig. 13):

- (1) Gently pry up top of bezel to release spring catches.
- (2) Tip forward and remove.

8.02 To remove 51A lamp:

- (1) Remove bezel assembly.
- (2) Remove light shield.
- (3) Insert orange stick beneath lamp.
- (4) Lift lamp from socket.

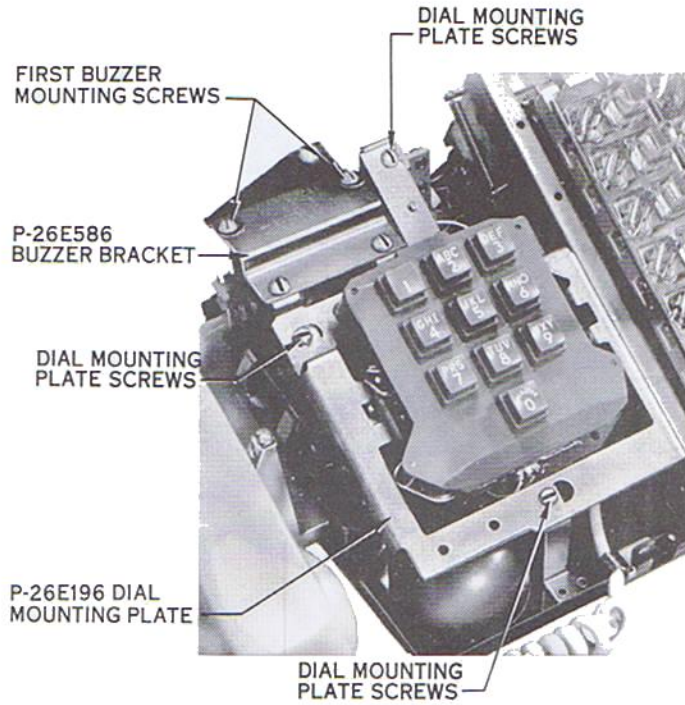

Fig. 11 - 1630-Type Telephone Set

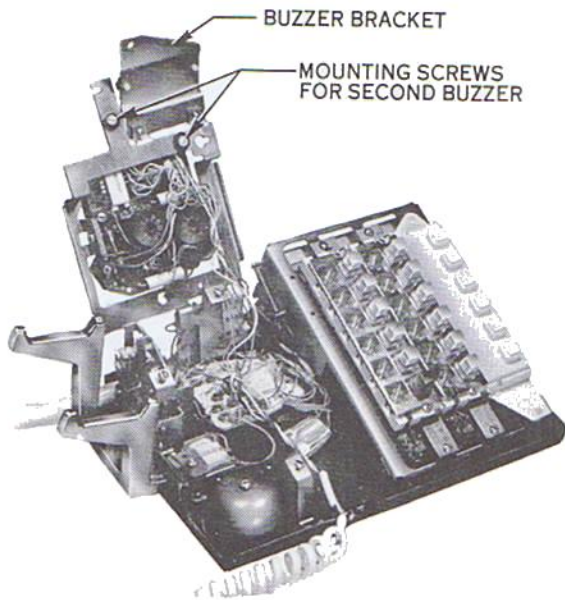

Fig. 12 - Mounting Location for Second Buzzer

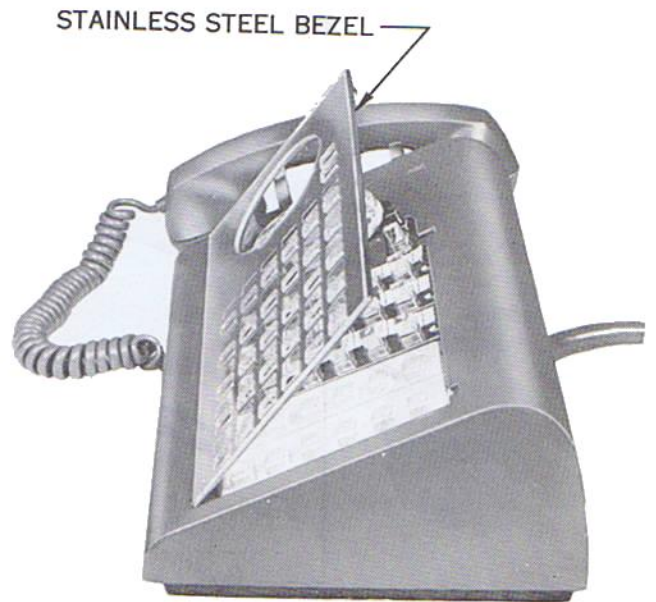

Fig. 13 - Removal of Bezel and Faceplate Assembly



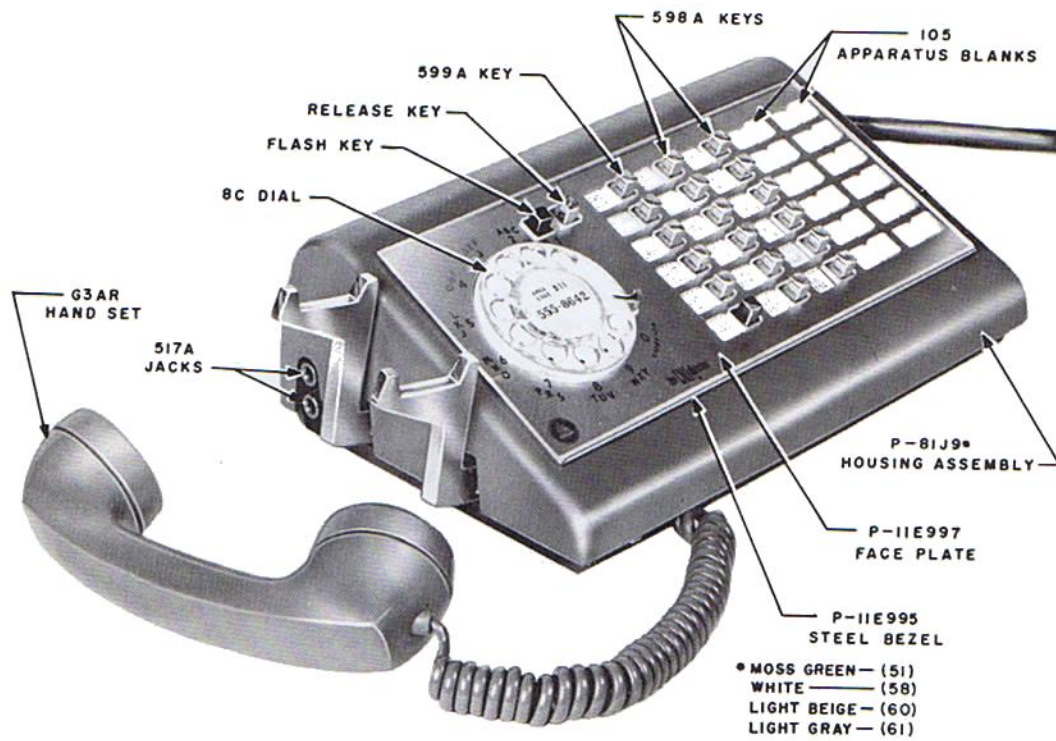

Fig. 14 - 639-Type Telephone Set

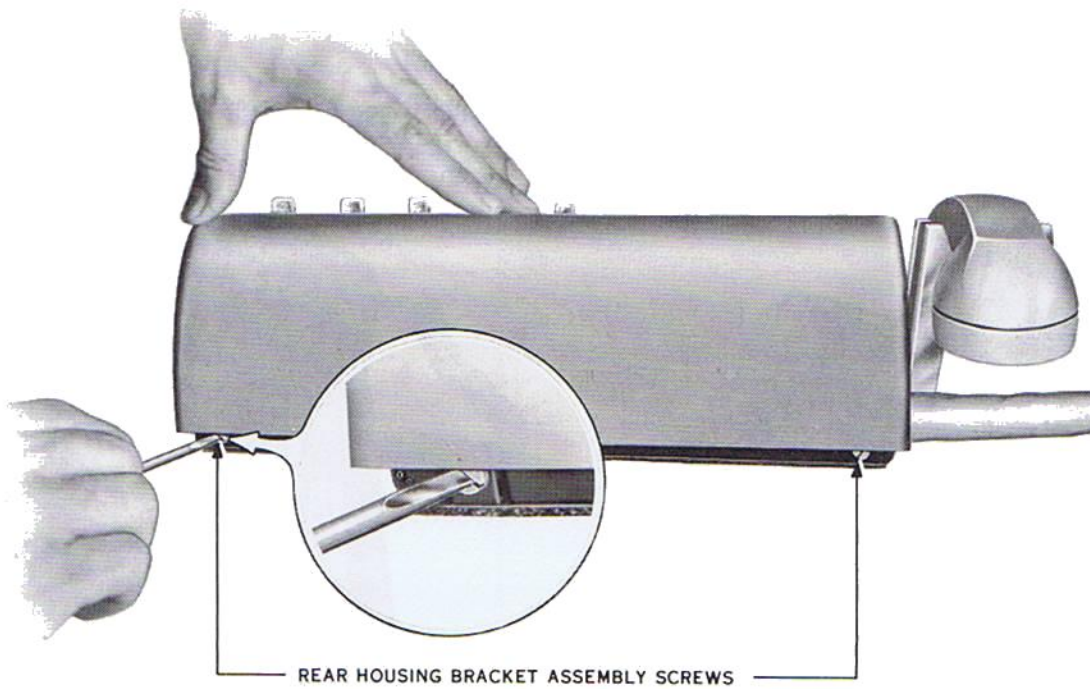

Fig. 15 - Method of Removing Housing



**Housing**

8.03 To remove housing (Fig. 15):

- (1) Remove bezel assembly.
- (2) Loosen two screws at rear of housing.
- (3) Lift rear of housing.
- (4) Move housing forward to free front mounting hooks.

**Key**

8.04 To remove key:

- (1) Remove bezel assembly.
- (2) Remove housing assembly.
- (3) Loosen screws at top and bottom of key (Fig. 16).
- (4) Grasp both ends of key and pull up to free connector.

(5) Slide key toward back of set until front end of key clears mounting frame.

(6) Raise front end of key to clear mounting frame.

(7) Slide key forward and up.

8.05 To install key (Fig. 17):



*When key is ordered separately, remove spring and pin from end of latch bar (Fig. 18) before installing.*

(1) Hold key by both ends of frame.

(2) Lower upper end of key into key well.

(3) Slide key toward rear of well until lower end clears mounting frame and goes into key well.

(4) Engage latch bar, plug, and connector.

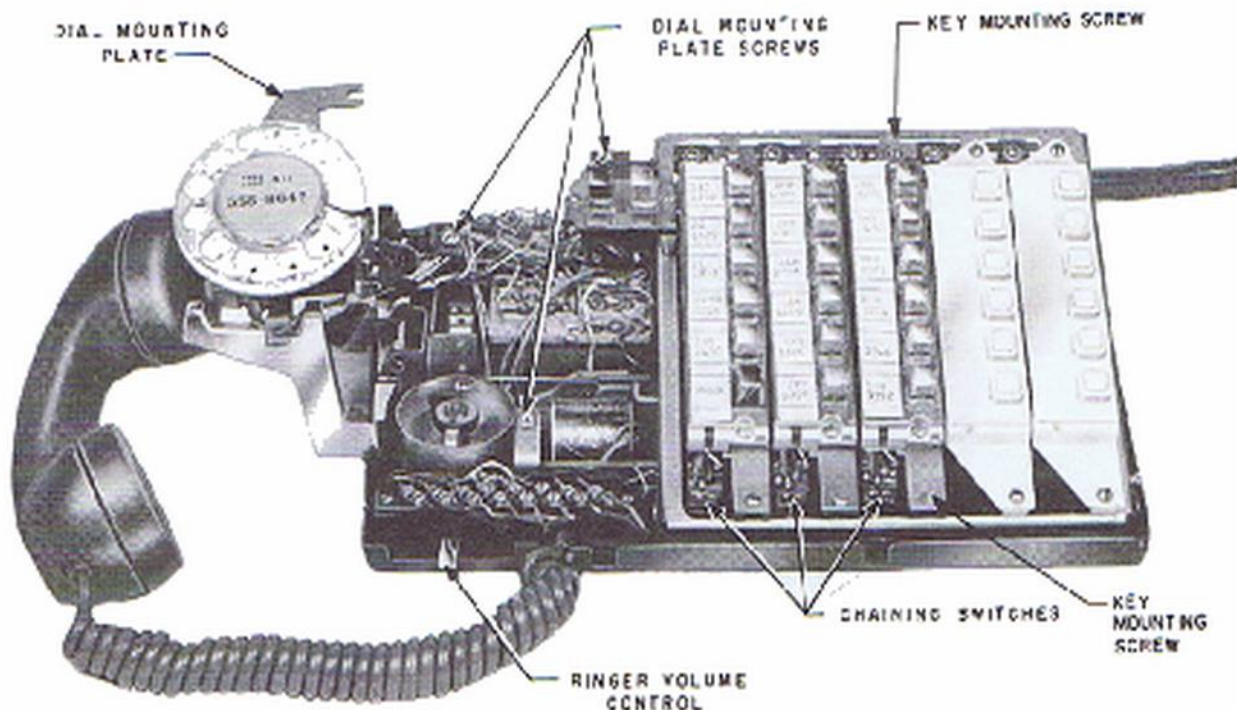

Fig. 16 — 639-Type Telephone Set, Dial Mounting Plate Lifted

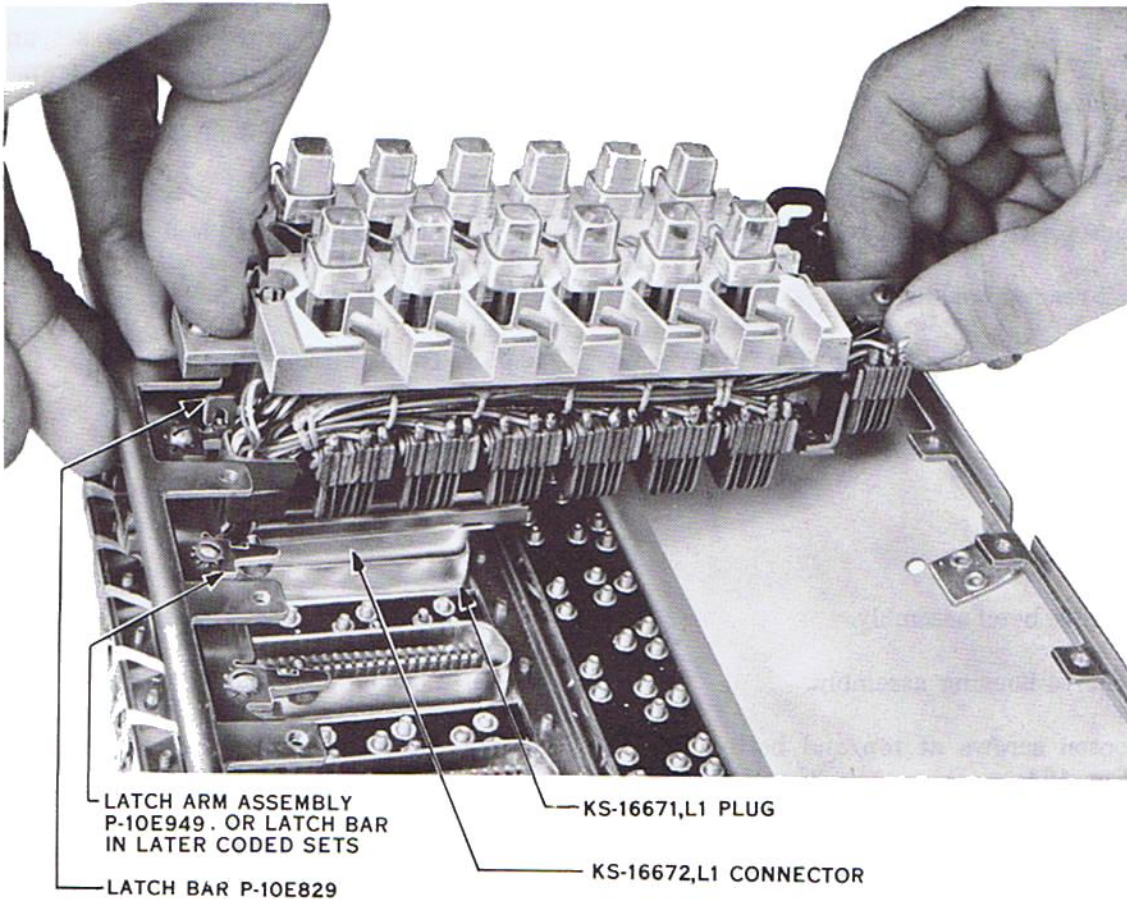

Fig. 17 — Method of Placing Key

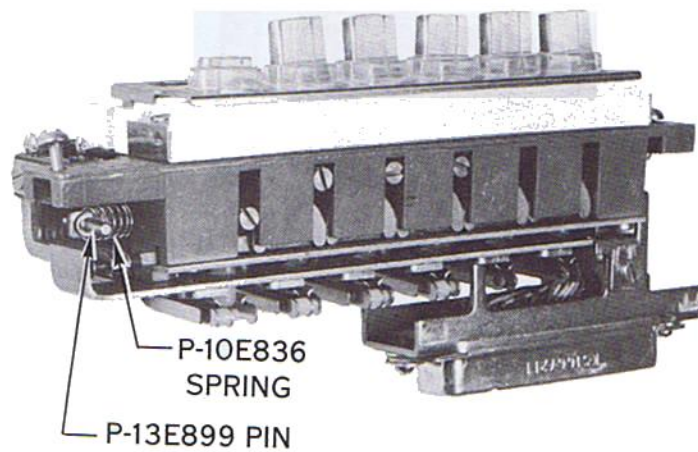

Fig. 18 — Latch Bar Spring and Pin



- (5) Push key firmly into place.
- (6) Tighten screws at top and bottom of key.
- (7) Test key for operation.
- (7) Remove mounting cord assembly screws (Fig. 19).
- (8) Pull down on mounting cord frame to disengage connector plugs (Fig. 20).

### Mounting Cord Assembly

**8.06** To remove mounting cord assembly:

- (1) Remove bezel assembly.
- (2) Remove housing assembly.
- (3) Remove mounting cord clamp.
- (4) Loosen key frame locking screws (Fig. 19).
- (5) Raise key frame.
- (6) Disconnect miscellaneous spade-tipped cord conductors.

### Dial

**8.07** To remove TOUCH-TONE dial:

- (1) Remove bezel and housing assemblies.
- (2) Remove buzzer mounting bracket.
- (3) Loosen dial mounting plate screws (Fig. 11).
- (4) Move mounting plate to left and lift off.
- (5) Disconnect dial leads.

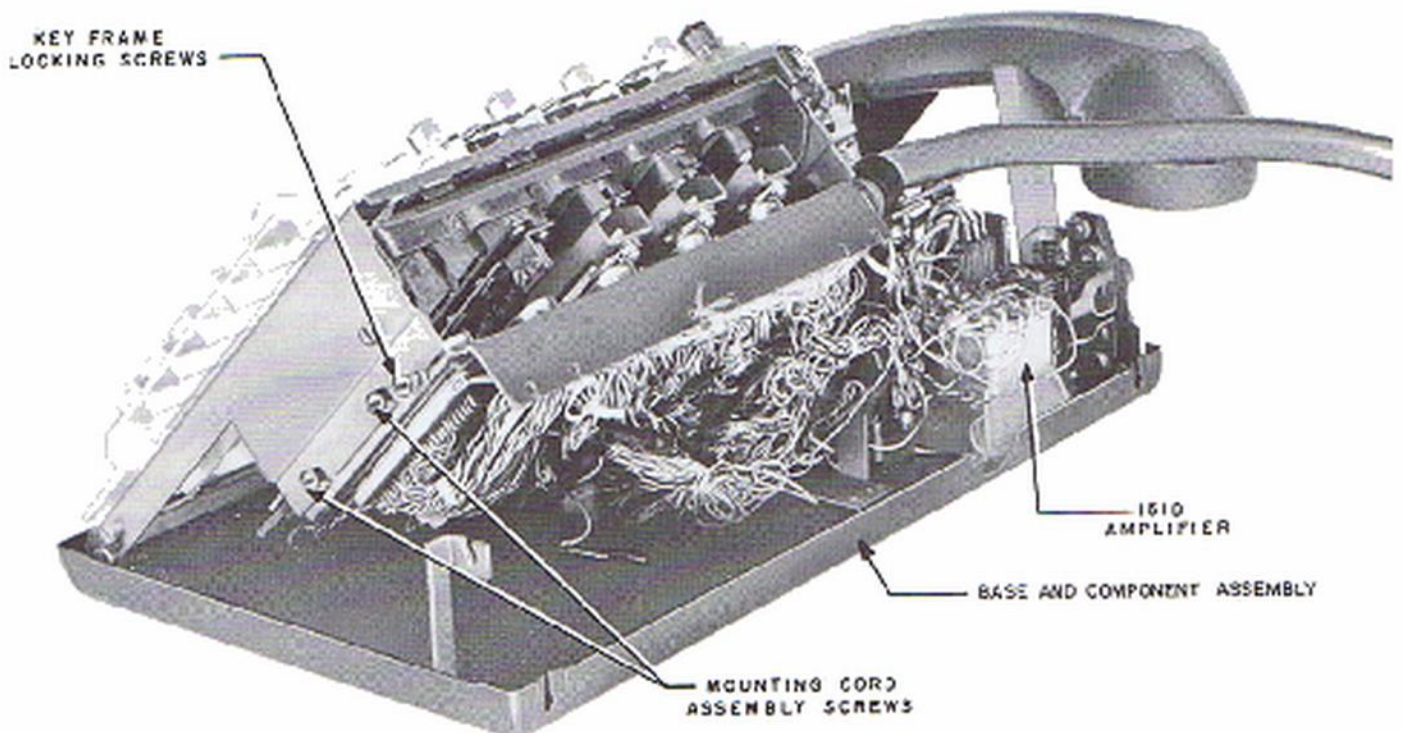

**Fig. 19 — 639-Type Telephone Set, Key Frame Lifted, Rear View**

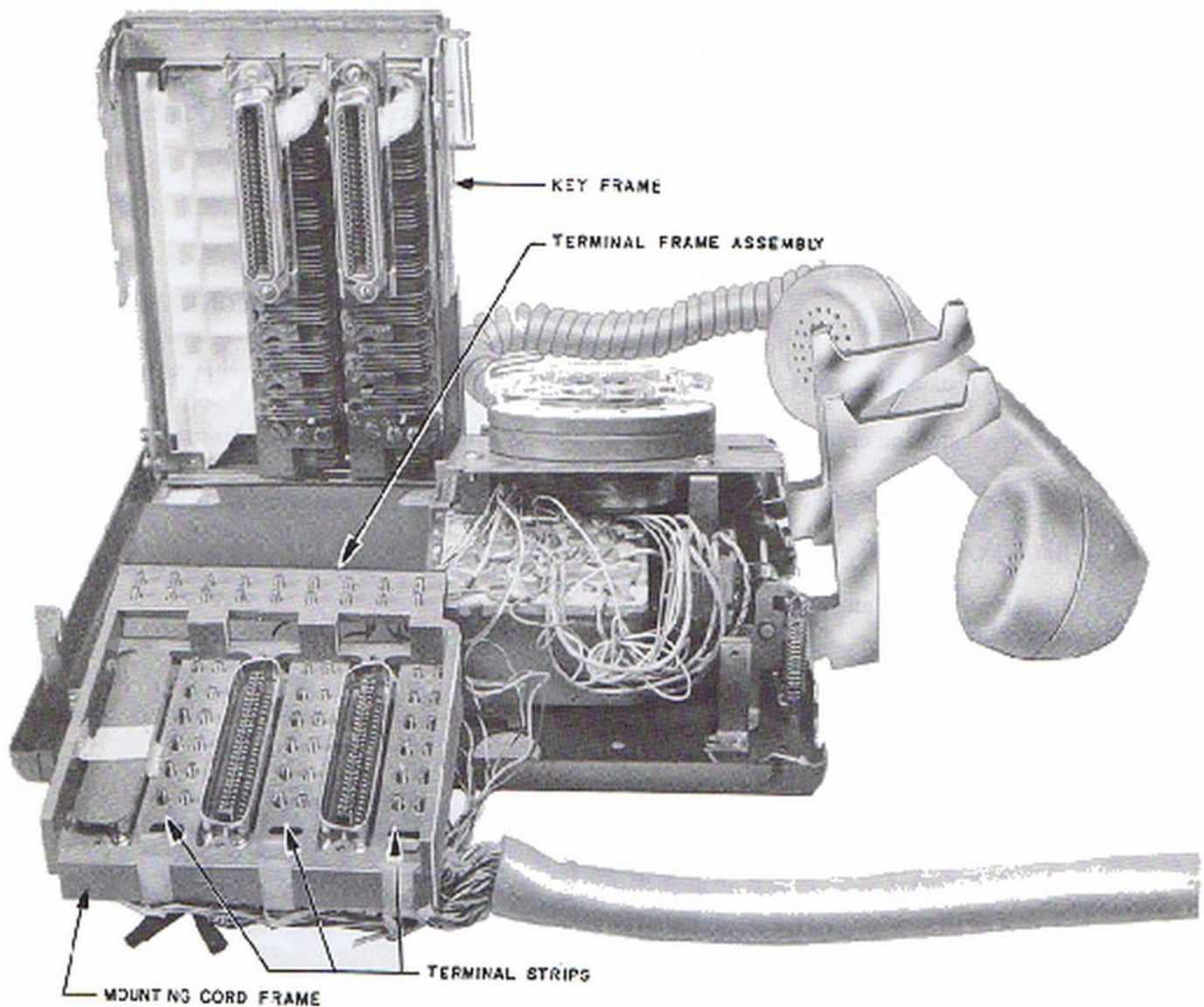

Fig. 20— 630-Type Telephone Set Showing Removal of Cord Frame

- (6) Remove dial mounting screws (Fig. 21).
- (7) Hold dial mounting plate in hand (Fig. 22).
- (8) Insert screwdriver blade as shown in Fig. 22.

**Caution:** No downward pressure on the screwdriver is required.

- (9) Tip screwdriver handle outward until positioning studs release. This action will raise side of dial (Fig. 23).
- (10) Grasp dial on diagonal corners (Fig. 24) and lift out. This method of handling dial will prevent damage of dial contacts.



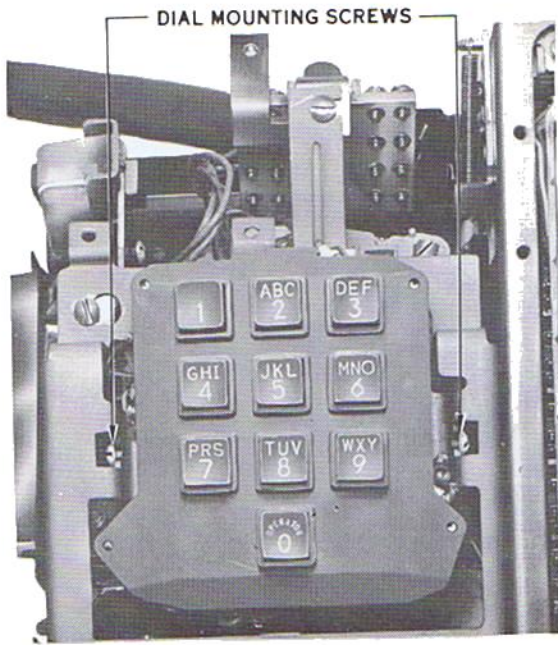

Fig. 21 - 1630-Type Telephone Set,  
Dial Mounting Screws

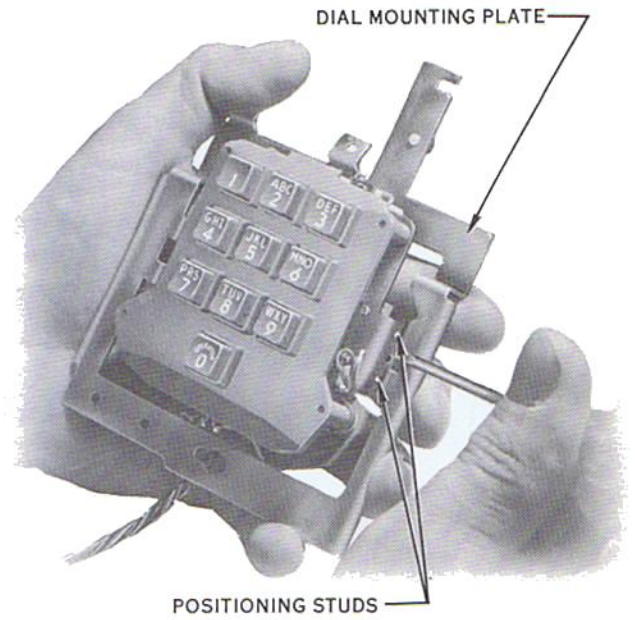

Fig. 23 - Removing Dial From  
Dial Mounting Plate

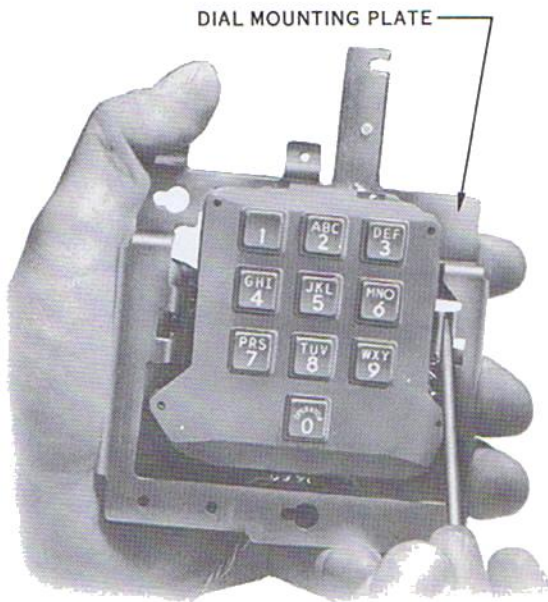

Fig. 22 - Removing TOUCH-TONE Dial  
From Dial Mounting Plate

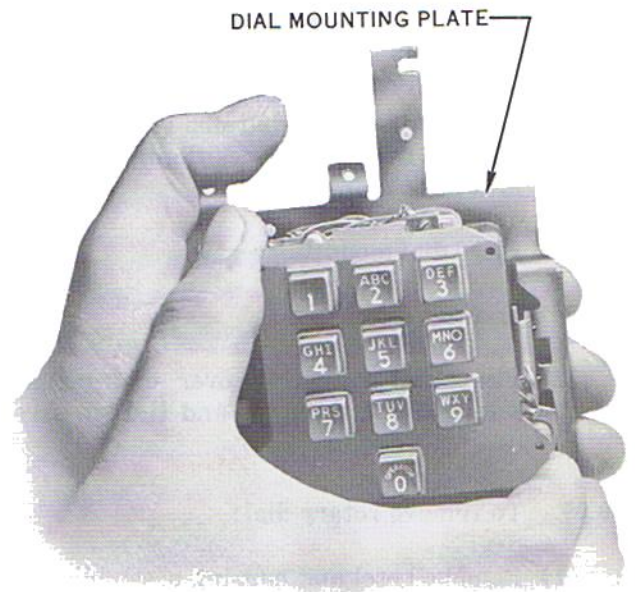
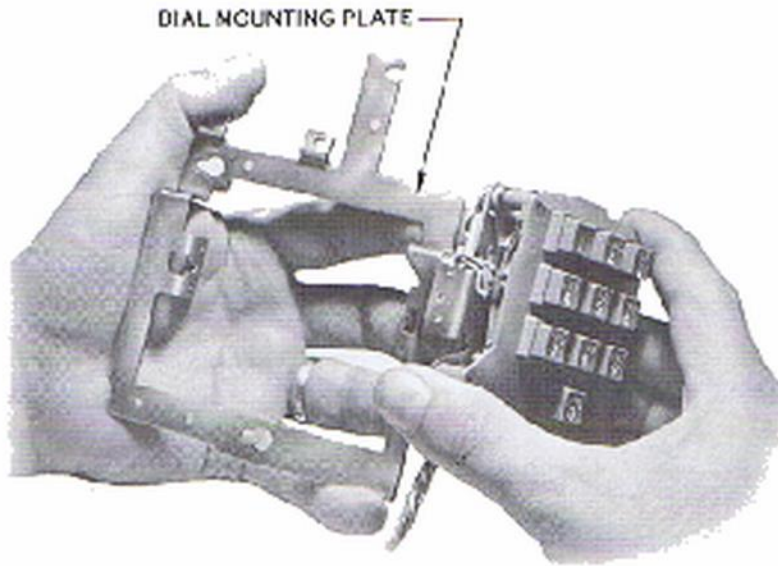

Fig. 24 - Lifting Dial From  
Dial Mounting Plate



**Fig. 25 — Holding Dial and Dial Bracket for Dial Replacement**

**8.08 To install dial:**

- (1) Hold mounting plate in hand (Fig. 25).
- (2) Grasp dial by diagonal corners (Fig. 25).
- (3) Lower side into dial mounting plate until positioning studs engage positioning holes.
- (4) Hold side of mounting plate on fingers (Fig. 26). Place thumb on top of dial beside middle row of pushbuttons (Fig. 26). Press dial downward until positioning studs snap into positioning holes.
- (5) Place dial mounting screws.
- (6) Connect dial leads.
- (7) Place dial mounting over dial mounting screws, slide to right, and tighten screws.

- (4) Move mounting plate to left and lift off.
- (5) Disconnect dial leads.
- (6) Remove dial mounting screws.

**8.09 To remove rotary dial:**

- (1) Remove bezel and housing assemblies.
- (2) Remove buzzer mounting bracket.
- (3) Loosen screws securing dial mounting plate.

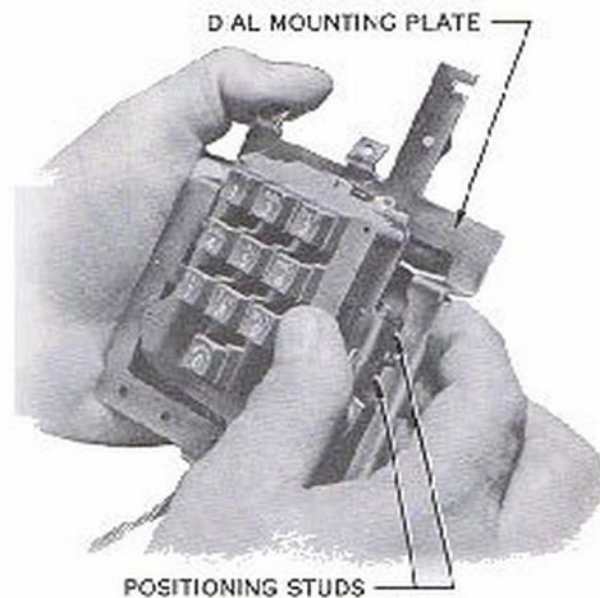

**Fig. 26 — Placing Dial on Dial Mounting Plate**



- (7) Hold dial mounting plate in hand (Fig. 27).
- (8) Insert screwdriver blade between dial and dial mounting plate with tip of blade under dial adapter bracket screw (Fig. 27). No downward pressure is required.
- (9) Tip screwdriver handle outward (Fig. 28). This action will disengage positioning studs and raise side of dial.
- (10) Grasp dial in hand and lift out.

#### 8.10 To install rotary dial:

- (1) Grasp dial mounting plate in hand.
- (2) Grasp dial in other hand and lower one side of dial into dial mounting plate until positioning studs engage positioning holes (Fig. 29).
- (3) Hold opposite side of dial mounting plate on fingers and with thumb in a position above dial finger stop. Press downward until positioning studs snap into positioning holes (Fig. 29).

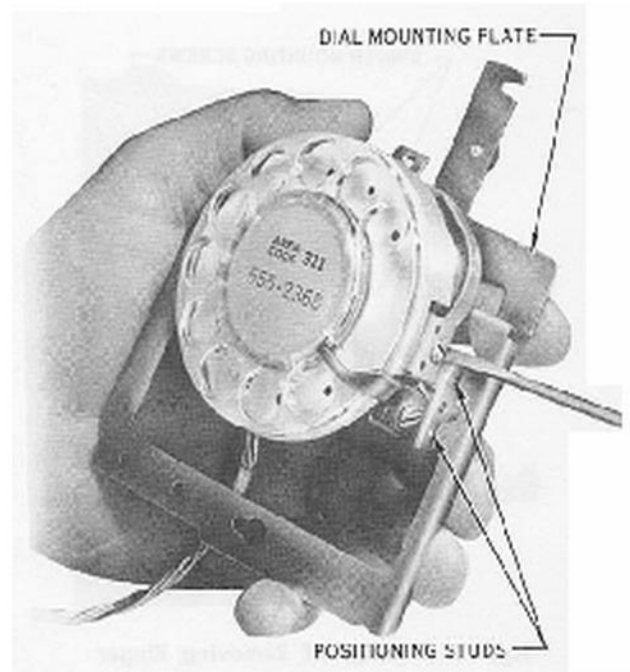

Fig. 28 – Removing Dial from Dial Mounting Plate

**Caution:** Press downward slowly, but firmly, or the excessive pressure may cause positioning studs to slide past positioning holes.

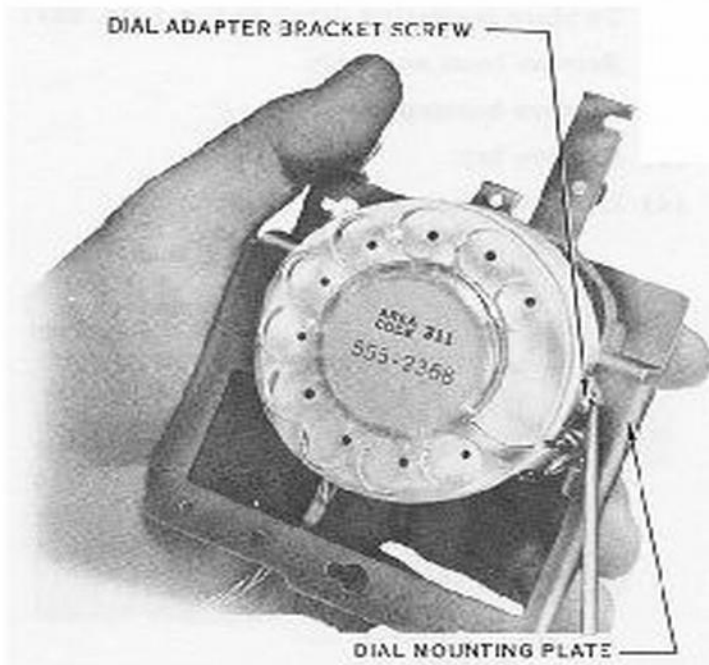

Fig. 27 – Holding Dial and Dial Mounting Bracket

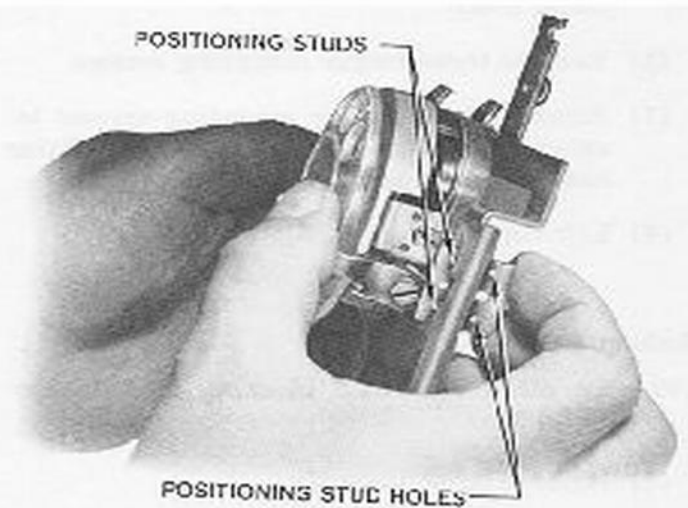

Fig. 29 – Placing Rotary Dial in Dial Mounting Plate

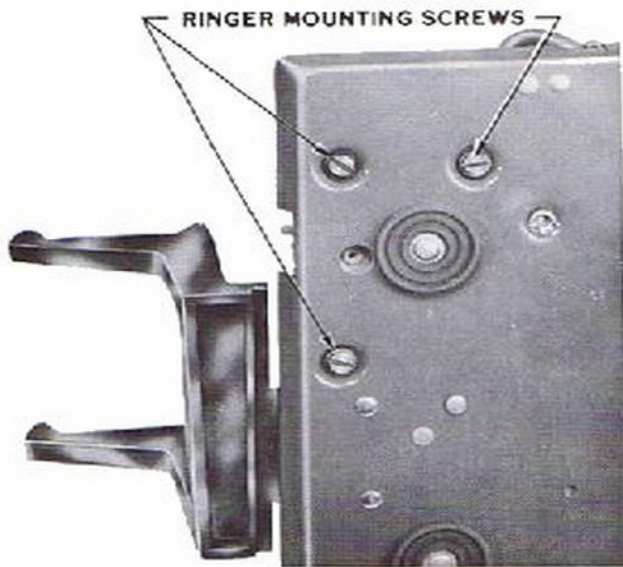

Fig. 30 – Method of Removing Ringer

**Ringer**

8.11 To remove ringer:

- (1) Remove bezel.
- (2) Remove housing.
- (3) Remove dial mounting plate.
- (4) Disconnect ringer leads.
- (5) Lift key and cord frame (earlier manufactured sets).
- (6) Remove three ringer mounting screws.
- (7) Remove three ringer mounting screws located in bottom of set (Fig. 30) (later manufactured sets).
- (8) Lift ringer out.

**Blocking Ring**

8.12 To place P-12A859 blocking ring in key (Fig. 31):

- (1) Remove bezel assembly.
- (2) Remove housing assembly.
- (3) Remove key.

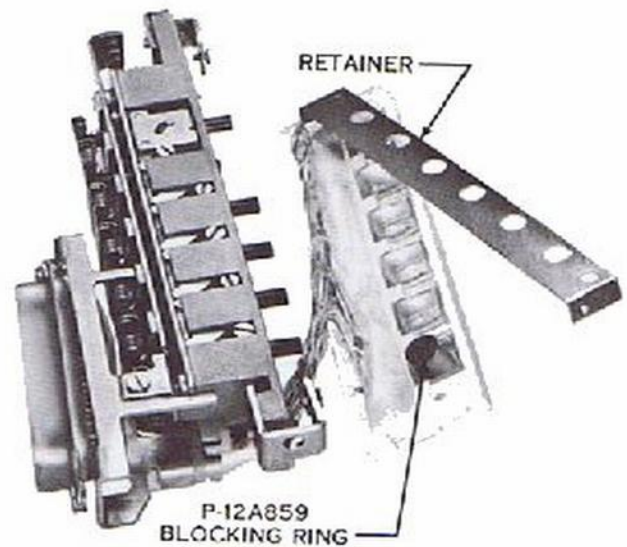

Fig. 31 – Method of Placing Blocking Ring

- (4) Remove lamp block assembly.
- (5) Remove button retainer.
- (6) Place blocking ring over plunger.
- (7) Replace button retainer and lamp block assembly.

**Insulating Detail**

8.13 To place insulating detail in key (Fig. 32):

- (1) Remove bezel assembly.
- (2) Remove housing assembly.
- (3) Remove key.
- (4) Insert insulating detail (Fig. 32).

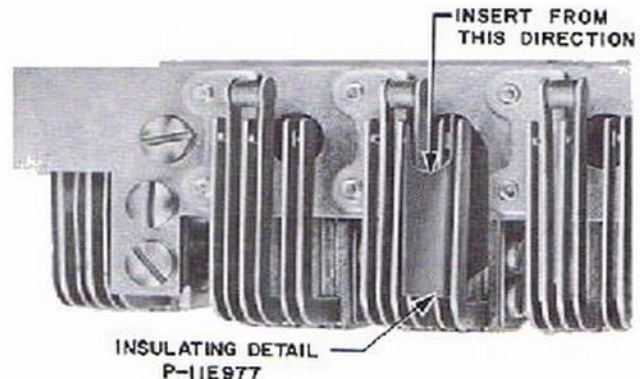
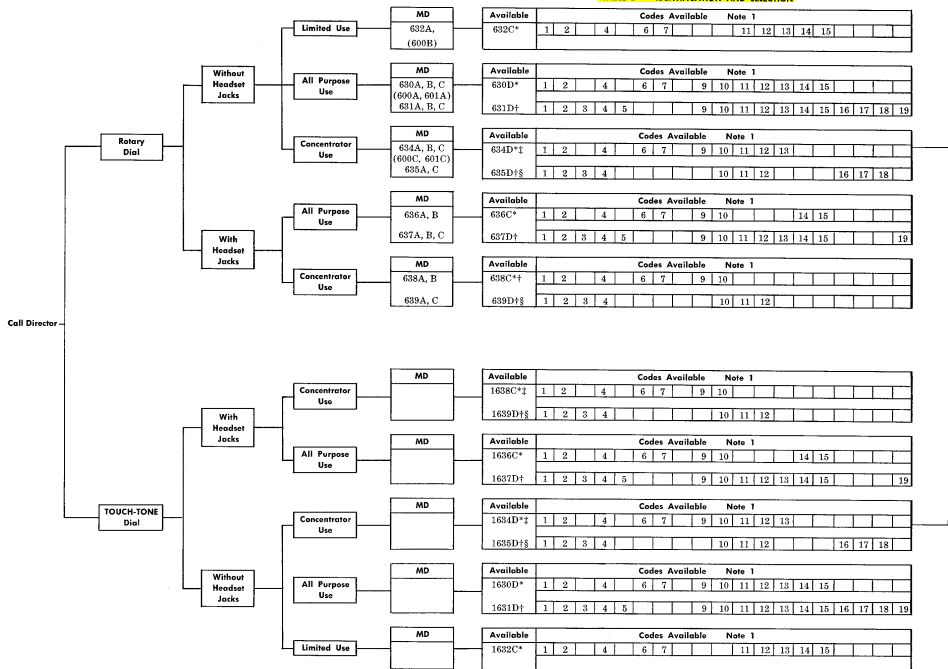

Fig. 32 – Part of 590 Series Key with P-11E977 Insulating Detail when Converted for Signaling



TABLE B IDENTIFICATION AND SELECTION



Code	Modular Key Arrangements** - 18 Button Sets		
	1st or Left Position	2nd Position	3rd Position
1	599A	598A	105B
2	599A	598A	598A
3			
4	599A	598A	617A
5			
6	599B	598A	105B
7	599B	598A	598A
8			
9	598A	598A	105B
10	598A	598A	598A
11	599A	598A	667A
12	599A	617A	667B
13	599B	598A	667B
14	599A	598A	59A
15	599B	598A	59A

Note: When ordering telephone sets, this code number must be succeeded by desired color code number. See Table A for color code.

- \* 18 button set
- † 30 button set
- ‡ 235A KTU must be used with each set
- § 236A KTU must be used with each set
- \*\* Component Description:
- 59A — lamp socket
- 105B — Apparatus blank
- 598A — Ps Ps Ps Ps Ps
- 599A — H Ps Ps Ps Ps
- 599B — H Ps Ps Ps C
- 617A — 12 button, 12 single make contacts
- 667A — Speakerphone transmitter
- 667B — Speakerphone transmitter

Code	Modular Key Arrangements** - 30 Button Sets				
	1st or Left Position	2nd Position	3rd Position	4th Position	5th Position
1	599A	598A	598A	105B	105B
2	599A	598A	598A	598A	105B
3	599A	598A	598A	598A	598A
4	599A	598A	598A	598A	617A
5	599A	598A	598A	617A	59A
6					
7					
8					
9	599A	598A	598A	105B	59A
10	599B	598A	598A	105B	105B
11	599B	598A	598A	598A	105B
12	599B	598A	598A	598A	599B
13	598A	598A	598A	105B	105B
14	598A	598A	598A	598A	105B
15	598A	598A	598A	598A	598A
16	599A	598A	598A	105B	667B
17	599A	598A	598A	598A	667B
18	599A	598A	598A	617A	667B
19	599A	598A	598A	598A	59A

**TABLE C**  
**TELEPHONE SET COMPONENTS AND CONNECTOR CABLE**

Type Set (Note 1)	Housing Assembly*	Bezel Assembly	Mounting Cord*†	Dial	Ringer	Hand Set*	Network	Amplifier	Swchk Assembly	A-Type Connector Cable	Buzzer Mounting Bracket
630A	P-81L5 --	P-11E903	D120A --	6L-41	D1A	G3AR --	425B			A75A	65A
630B			D120B --								
630C			D120C --								
630D	P-84C0 --	P-26E199		8C-58	N1A		4010B				P-26E586
631A	P-81L4 --	P-11E902	D200A --	6L-41	D1A		425B			A100A or A100D	65A
631B			D200B --								
631C			D200F --								
631D	P-84C1 --	P-26E212		8C-58	N1A		4010B				
632A	P-81L5 --	P-11E903	D94A --	6L-41	D1A		425B			A75A	65A
632C	P-84C0 --	P-26E199	D94B --	8C-58	N1A		4010B				P-26E586
634A	P-81L5 --	P-11E903	D50A --	6L-41	D1A		425E			A25B	65A
634B			D50B --								
634C			D50L --								
634D	P-84C0 --	P-26E199		8C-58	N1A		4010B				P-26E586
635A	P-81L4 --	P-11E902	D80A --	6L-41	D1A		425B			A40A	65A
635C			D80B --								
635D	P-84C1 --	P-26E212		8C-58	N1A		4010B				P-26E586
636A†	P-81J8 --	P-11E994	D120B --		D1B		425D	151D	P-11E987	A75A	71A
636B†			D120C --								
636C†	P-84C2 --	P-26E199			N1A		4010B	241A	P-24E770		P-26E586
637A†	P-81J9 --	P-11E995	D200B --		D1B		425D	151D	P-11E987	A100A or A100D	71A
637C†			D200F --								
637D†	P-84C3 --	P-26E212			N1A		4010B	241A	P-24E770		P-26E586
638A†	P-81J8 --	P-11E994	D50B --		D1B		425D	151D	P-11E987	A25B	71A
638B†			D50L --								
638C†	P-84C2 --	P-26E199			N1A		4010B	241A	P-24E770		P-26E586

**TABLE C (Contd)**  
**TELEPHONE SET COMPONENTS AND CONNECTOR CABLE**

Type Set (See Note)	Housing Assembly*	Bezel Assembly	Mounting Cord*†	Dial	Ringer	Hand Set*	Network	Amplifier	Switchhook Assembly	A-Type Connector Cable	Buzzer Mounting Bracket
639A†	P-81J9 --	P-11E995	D80A --	25B3	D1B	G3AR --	425D	151D	P-11E987	A40A	71A
639C†			D80B --								
639D†	P-84C3 --	P-26E212			N1A		4010B	241A	P-24E770		P-26E586
1630D	P-84C0 --	P-26E199	D120C --		N1A		4010B			A75A	P-26E586
1631D	P-84C1 --	P-26E212	D200F --							A100A or A100D	
1632C	P-84C0 --	P-26E199	D94B --							A75A	
1634D			D50L --				A25B				
1635D	P-84C1 --	P-26E212	D80B --						A40A		
1636C†	P-84C2 --	P-26E199	D120C --					241A	P-24E770	A75A	
1637D†	P-84C3 --	P-26E212	D200F --							A100A or A100D	
1638C†	P-84C2 --	P-26E199	D50L --							A25B	
1639D†	P-84C3 --	P-26E212	D80B --							A40A	
600A	P-81F5 --		D120A --	6L-41	D1A		425E			M150A or A75A	65A
600B			D94A --								
600C			D50A --								
601A	P-81F4 --		D200A --							M200A, A100A, or A100D	
601C			D80A --				A40A				

Note: All sets in above table use a G3AR hand set.

\* Add color suffix when ordering.

† Indicates these sets are equipped with two 517A jacks arranged to receive a 289B plug for headset operation.

‡ Indicates mounting cords are supplied in 3-foot lengths.



MATS AND FACEPLATES

TABLE D  
MATS AND FACEPLATES

Telephone Set		Faceplate Assembly *	Faceplate Only	Nonglare Faceplate Assembly *	Nonglare Faceplate Only	Set of five Mats	Individual Mats										
Type	Code						Gold	Blue	Green	Cream White	Silver						
630A 634A	1, 2, 6, 7, 9, and 10	20A	P-11E904	20A1	P-25E620	P-13E549	P-11E897	P-11E898	P-11E899	P-11E900	P-11E901						
	3, 8, 11, and 13	20C	P-12E438	20C1	P-25E622	P-13E550	P-12E444	P-12E445	P-12E446	P-12E447	P-12E448						
	4	20B	P-12E440	20B1	P-25E621	P-13E549	P-11E897	P-11E898	P-11E899	P-11E900	P-11E901						
	5 and 12	20D	P-12E439	20D1	P-25E623	P-13E550	P-12E444	P-12E445	P-12E446	P-12E447	P-12E448						
	1, 2, 6, 7, 9, and 10	20A	P-11E904	20A1	P-25E620	P-13E549	P-11E897	P-11E898	P-11E899	P-11E900	P-11E901						
630B 630D	4	20B	P-12E440	20B1	P-25E621	P-13E550	P-12E444	P-12E445	P-12E446	P-12E447	P-12E448						
	11 and 13	20C	P-12E438	20C1	P-25E622												
	12	20D	P-12E439	20D1	P-25E623												
	14 and 15	20J	P-15E710	20J1	P-25E628												
	1, 2, 6, 7, 8, 9, and 10	20A	P-11E904	20A1	P-25E620												
630C	4	20B	P-12E440	20B1	P-25E621	P-13E550	P-11E897	P-11E898	P-11E899	P-11E900	P-11E901						
	11 and 13	20C	P-12E438	20C1	P-25E622												
	12	20D	P-12E439	20D1	P-25E623												
	14 and 15	20J	P-15E710	20J1	P-25E628												
	1, 2, 3, 10, 11, 12, 13, 14, and 15	21A	P-11E905	21A1	P-25E629							P-13E552	P-11E892	P-11E893	P-11E894	P-11E895	P-11E896
631A	4	21B	P-12E441	21B1	P-25E630	P-13E552	P-11E892	P-11E893	P-11E894	P-11E895	P-11E896						
	5	21E	P-12E733	21E1	P-25E633												
	6, 7, 16, and 17	21C	P-12E442	21C1	P-25E631							P-13E553	P-12E459	P-12E460	P-12E461	P-12E462	P-12E463
	8 and 18	21D	P-12E443	21D1	P-25E632												
	9 and 19	21F	P-12E734	21F1	P-25E634												
631B 631D	1, 2, 3, 10, 11, 12, 13, 14, and 15	21A	P-11E905	21A1	P-25E629	P-13E552	P-11E892	P-11E893	P-11E894	P-11E895	P-11E896						
	4	21B	P-12E441	21B1	P-25E630												
	5	21E	P-12E733	21E1	P-25E633												
	9 and 19	21F	P-12E734	21F1	P-25E634												
	16 and 17	21C	P-12E442	21C1	P-25E631							P-13E553	P-12E459	P-12E460	P-12E461	P-12E462	P-12E463
18	21D	P-12E443	21D1	P-25E632													
600A 600B 600C			P-10E945† P-10E946				P-11E012	P-11E013	P-11E014	P-11E015	P-10E935						
601A 601C			P-10E945† P-10E947				P-11E016	P-11E017	P-11E018	P-11E019	P-10E948						

TABLE D (Contd)

Telephone Set		Faceplate Assembly *	Faceplate Only	Nonglare Faceplate Assembly *	Nonglare Faceplate Only	Set of five Mats	Individual Mats											
Type	Code						Gold	Blue	Green	Cream White	Silver							
631C	1, 2, 3, 10, 11, 12, 13, 14, and 15	21A	P-11E905	21A1	P-25E629	P-13E552	P-11E892	P-11E893	P-11E894	P-11E895	P-11E896							
	4	21B	P-12E441	21B1	P-25E630													
	5	21E	P-12E733	21E1	P-25E633													
	9	21F	P-12E734	21F1	P-25E634													
	16 and 17	21C	P-12E442	21C1	P-25E631							P-13E553	P-12E459	P-12E460	P-12E461	P-12E462	P-12E463	
	18	21D	P-12E443	21D1	P-25E632													
	19	21K	P-12E740	21K1	P-25E638													
	632A 632C	1, 2, 6, and 7	20A	P-11E904	20A1							P-25E620	P-13E549	P-11E897	P-11E898	P-11E899	P-11E900	P-11E901
		4	20B	P-12E440	20B1							P-25E621						
11 and 13		20C	P-12E438	20C1	P-25E622													
12		20D	P-12E439	20D1	P-25E623													
14 and 15		20J	P-15E710	20J1	P-25E628													
634B 634C 634D	1, 2, 6, 7, 9, and 10	20A	P-11E904	20A1	P-25E620	P-13E549	P-11E897	P-11E898	P-11E899	P-11E900	P-11E901							
	4	20B	P-12E440	20B1	P-25E621													
	11 and 13	20C	P-12E438	20C1	P-25E622													
	12	20D	P-12E439	20D1	P-25E623													
635A 635C 635D	1, 2, 3, 10, 11, and 12	21A	P-11E905	21A1	P-25E629	P-13E552	P-11E892	P-11E893	P-11E894	P-11E895	P-11E896							
	4	21B	P-12E441	21B1	P-25E630													
	16 and 17	21C	P-12E442	21C1	P-25E631							P-13E553	P-12E459	P-12E460	P-12E461	P-12E462	P-12E463	
	18	21D	P-12E443	21D1	P-25E632													
636A 636B 636C	1, 2, 6, 7, 9, and 10	20E	P-11E996	20E1	P-25E624	P-13E564	P-12E003	P-12E004	P-12E005	P-12E006	P-12E007							
	4	20F	P-12E747	20F1	P-25E625													
	14 and 15	20H	P-15E711	20H1	P-25E627													
637A 637C 637D	1, 2, 3, 10, 11, 12, 13, 14, and 15	21G	P-11E997	21G1	P-25E635	P-13E551	P-11E998	P-11E999	P-11E000	P-11E001	P-11E002							
	4	21H	P-12E748	21H1	P-25E636													
	5	21J	P-12E746	21J1	P-25E637													
	9 and 19	21K	P-12E740	21K1	P-25E638													
638A 638B 638C	1, 2, 6, 7, 9, and 10	20E	P-11E996	20E1	P-25E624	P-13E564	P-12E003	P-12E004	P-12E005	P-12E006	P-12E007							
	4	20F	P-12E747	20F1	P-25E625													
	1, 2, 3, 10, 11, and 12	21G	P-11E997	21G1	P-25E635							P-13E551	P-11E998	P-11E999	P-11E000	P-11E001	P-11E002	
4	21H	P-12E748	21H1	P-25E636														

TABLE D (Contd)  
MATS AND FACEPLATES

Telephone Set		Faceplate Assembly *	Faceplate Only	Nonglare Faceplate Assembly *	Nonglare Faceplate Only	Set of five Mats	Individual Mats										
Type	Code						Gold	Blue	Green	Cream White	Silver						
1630D 1634D	1, 2, 6, 7, 9, and 10	120A	P-26E230	120A1	P-26E255	P-26E217	P-26E330	P-26E340	P-26E350	P-26E360	P-26E370						
	4	120B	P-26E231	120B1	P-26E256												
	11 and 13	120C	P-26E232	120C1	P-26E257							P-26E219	P-26E332	P-26E342	P-26E352	P-26E362	P-26E372
	12	120D	P-26E233	120D1	P-26E258												
	14 and 15	120J	P-26E238	120J1	P-26E263												
1631D	1, 2, 3, 10, 11, 12, 13, 14, and 15	121A	P-26E280	121A1	P-26E305	P-26E220	P-26E380	P-26E390	P-26E400	P-26E410	P-26E420						
	4	121B	P-26E284	121B1	P-26E309												
	5	121E	P-26E286	121E1	P-26E311												
	9 and 19	121F	P-26E288	121F1	P-26E313												
	16 and 17	121C	P-26E283	121C1	P-26E308							P-26E222	P-26E382	P-26E392	P-26E402	P-26E412	P-26E422
	18	121D	P-26E281	121D1	P-26E306												
	1632C	1, 2, 6, and 7	120A	P-26E230	120A1							P-26E255	P-26E217	P-26E330	P-26E340	P-26E350	P-26E360
C4	120B	P-26E231	120B1	P-26E256													
11 and 13	120C	P-26E232	120C1	P-26E257													
12	120D	P-26E233	120D1	P-26E258													
14 and 15	120J	P-26E238	120J1	P-26E263													
1635D	1, 2, 3, 10, 11, and 12	121A	P-26E280	121A1	P-26E305	P-26E220	P-26E380	P-26E390	P-26E400	P-26E410	P-26E420						
	4	121B	P-26E284	121B1	P-26E309												
	16 and 17	121C	P-26E283	121C1	P-26E308												
	18	121D	P-26E281	121D1	P-26E306												
1636C	1, 2, 6, 7, 9, and 10	120E	P-26E234	120E1	P-26E259	P-26E218	P-26E331	P-26E341	P-26E351	P-26E361	P-26E371						
	4	120F	P-26E235	120F1	P-26E260												
	14 and 15	120H	P-26E237	120H1	P-26E262												
1637D	1, 2, 3, 10, 11, 12, 13, 14, and 15	121G	P-26E289	121G1	P-26E314	P-26E221	P-26E381	P-26E391	P-26E401	P-26E412	P-26E422						
	4	121H	P-26E285	121H1	P-26E310												
	5	121J	P-26E287	121J1	P-26E312												
	9 and 19	121K	P-26E282	121K1	P-26E307												
1638C	1, 2, 6, 7, 9, and 10	120E	P-26E234	120E1	P-26E259	P-26E218	P-26E331	P-26E341	P-26E351	P-26E361	P-26E371						
	4	120F	P-26E235	120F1	P-26E260												
1639D	1, 2, 3, 10, 11, and 12	121G	P-26E289	121G1	P-26E314	P-26E221	P-26E381	P-26E391	P-26E401	P-26E412	P-26E422						
	4	121H	P-26E285	121H1	P-26E310												

\* Consists of a faceplate and five mats colored gold, blue, green, cream white, and silver.  
† Plastic faceplate to cover dial.

**TABLE E**  
**CONVERSION OF 600 AND 601-TYPE SETS\***

Convertible Telephone Sets*		Required Components		
From	To	Bezel	Faceplate Assembly	Slotted Housing
600A	630A	P-11E903	20A‡	P-81L5‡
600B	632B			
600C	634A			
601A	631A	P-11E902	21A‡	P-81L4‡
601C	635A			

\* Conversion procedure:

- (1) Remove faceplate, mat, and housing.
- (2) Remove three metal clips from the dial which support dial faceplate.
- (3) Remove wire clips at top and bottom of each modular unit.
- (4) Install new housing, bezel, and faceplate assembly.

‡ Add color suffix when ordering.

‡ Consists of faceplate and five mats colored gold, blue, green, cream white, and silver.