

KS-19340 BOOTH — INDOOR

INSTALLATION

1. GENERAL

1.01 This section describes how to install the KS-19340 wooden telephone booth and booth components.

1.02 This section is reissued to:

- Add information on KS-19340, List 56 sign control assembly
- Add information on KS-19340, List 57 and List 58 signs
- Revise illustrations

Since this reissue covers a general revision, arrows ordinarily used to indicate changes have been omitted.

2. LOCATING

2.01 The overall dimensions of a single booth are shown on Fig. 1.

2.02 The overall width of multiple installations (up to five) is shown in Table A.

TABLE A

NO. OF BOOTHS	OVERALL WIDTH
2	5 Ft.
3	7 Ft. 5-5/8 In.
4	9 Ft. 11-1/4 In.
5	12 Ft. 4-7/8 In.

2.03 Booth location should be:

- Within full view of public
- Readily accessible to customer
- Free of hazards

- Away from heat, flushing traps, or sinks
- Clear of wall switches, outlets, or fuse boxes
- In sufficient space to permit access to top of booth for maintenance purposes.

3. ASSEMBLING AND PLACING

3.01 Booths are shipped assembled unless order states otherwise. When shipped unassembled, all necessary screws and material are included in the shipment.



...Screw holes are aligned to simplify assembly in the field. When assembled, the sides of the booth unit shall make contact with the panels or separators along entire length of the booth unit.

PANELS AND SEPARATORS

3.02 End panels and separators are attached with eight No. 10 by 1-3/4 BH wood screws. The back panel is attached with ten No. 9 by 1-3/4 FH wood screws.

3.03 A booth separator should be substituted for a finished end panel when the end of the booth is not exposed.

LEVELING

3.04 Set booth level on floor so that it does not rock. Where floor is uneven or not level, place wooden shims under the proper side of booth to level it. Shims also should be placed under the middle of floor to prevent sagging. To prevent binding, the top of door must be aligned parallel with booth door frame when door is closed.

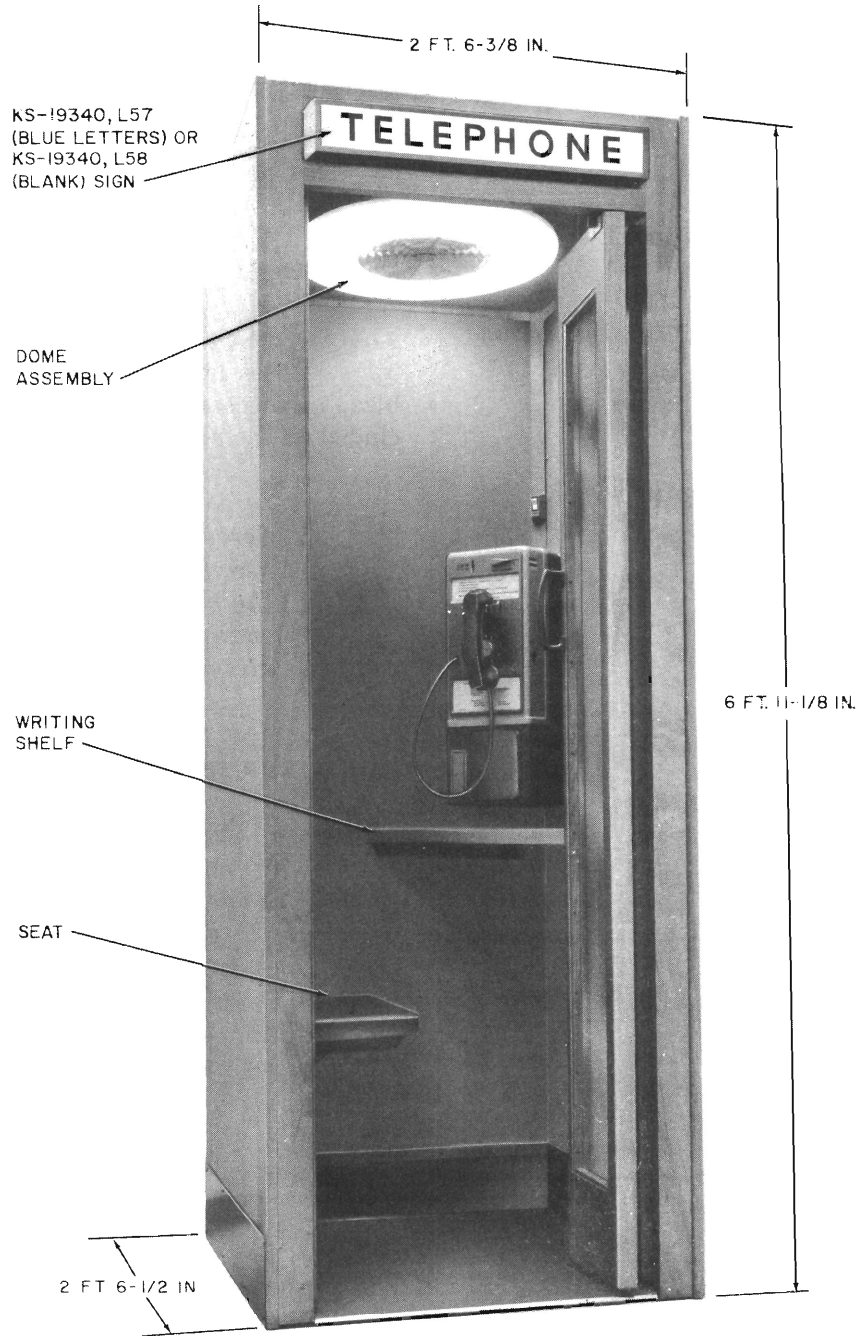

Fig. 1 — KS-19340 Booth

3.05 The booth must be level to insure proper operation of the coin telephone. Level as follows:

- (1) Place a dime (or mark a 3/4 in. circle) as shown in Fig. 2.
- (2) Suspend a plumb line (obtain locally), as shown in Fig. 2, from a tack placed temporarily in center of top edge of booth.

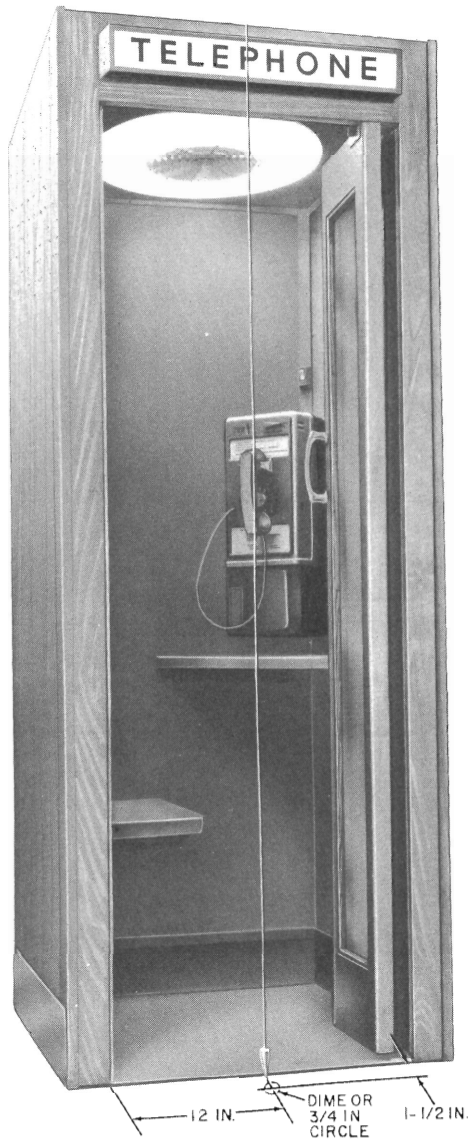

Fig. 2 — KS-19340 Booth With Plumb Line

(3) Shim the booth, as described in 3.04, until the plumb line is centered within area of dime or marked circle.

3.06 Avoid setting booths on floor with considerable slope such as ramps or inclined passageways. When this location cannot be avoided, be sure each booth is placed level with a minimum amount of step-up. In multiple installations of this type:

- Attach separator to highest booth first.
- Line up booths so that the fronts present a straight line before attempting to fasten them together.
- Exposed gap of 1/4-inch or more between the floor and the booth requires sealing with strips of wood. Stain strips to match the finish of the booth.

4. TELEPHONE WIRING

4.01 When selecting the type wire or cable, refer to section entitled Selection of Wire and Cable.

4.02 Signaling ground requirements are shown in Table B.

TABLE B

NUMBER OF BOOTHS	OPTIONS		
	CABLE PAIRS	CONDUCTORS OF STATION WIRE	NO. 14 GROUND WIRE
1 to 6	1	1	1
6 to 12	2	2	1
12 or more	1 pr per 6 booths	1 pr per 6 booths	1

4.03 When using triple conductor wire, run wire to the 42A connecting block of each booth. This connecting block is located in the ceiling on the rear of the booth.



... To gain access to this connecting block, remove the roof assembly which is held in place by four No. 9 by 1-inch flat-head screws.

4.04 Inside wiring cable terminates on a suitable connecting block. This block should be installed in the immediate vicinity or in the ceiling of one booth.

4.05 When a subscriber set is required, drill a 5/8-inch hole for access to the wiring channel in accordance with Fig. 3.



Exercise care when drilling to prevent bit from marring end panel.

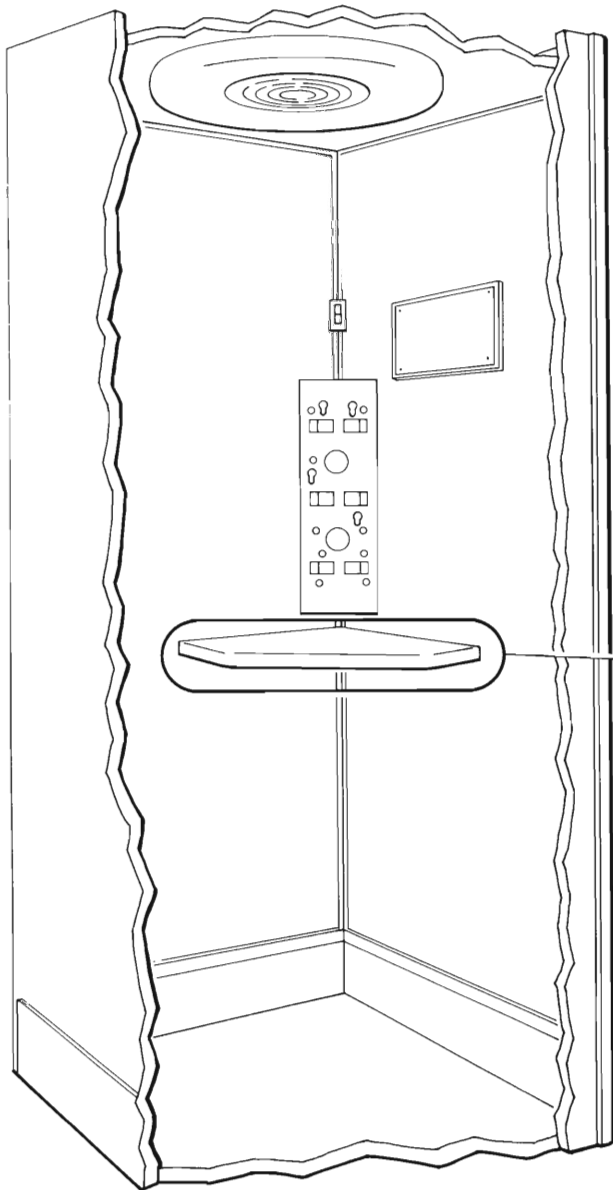

SUBSCRIBER SET INSTALLATION

4.06 The writing shelf is equipped with brackets for accepting the subscriber set mounting plate. Install the plate in accordance with Fig. 4.

5. ELECTRICAL WIRING

5.01 A 3-wire, grounded electrical outlet should be provided at booth location. Ensure that the third wire is grounded.

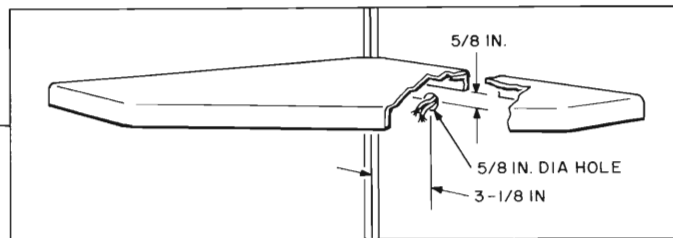

Fig. 3 — Requirements for Subscriber Set Wire Access Hole

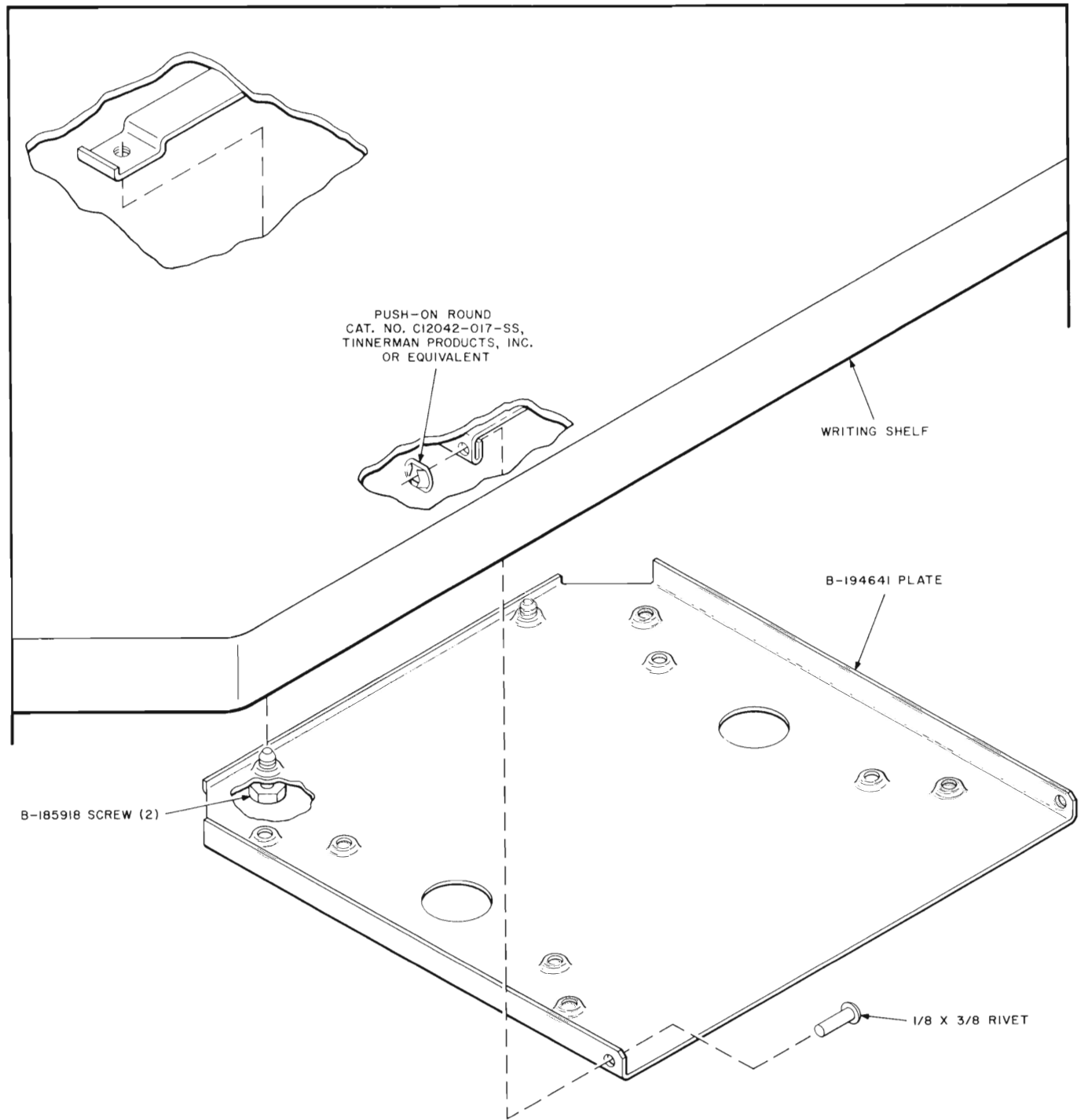

Fig. 4 — Subscriber Set Mounting

5.02 The booth is equipped with a KS-19425, List 22 cable assembly. This assembly is a rubber-covered 3-wire cord 64 inches long equipped with a 3-wire plug which terminates in the electrical receptacle located in the ceiling of the booth.



A ground wire (No. 14 gauge) is connected between the ground terminal of the electrical receptacle and the back-board. The purpose of this ground wire is to prevent exposing customers to electric shock from defective current-carrying coin telephone mounted in the booth. Verify that there is continuity between the ground terminal in the electrical receptacle and the coin telephone.

5.03 Connect the power cord to the spare receptacle of adjacent booth in multiple installations.

KS-19340, LIST 56 SIGN CONTROL ASSEMBLY

5.04 The KS-19340, List 56 sign control assembly (Fig. 5) is optional. It may be used to provide switch control for the illuminated KS-16422 telephone sign when it is installed in the vicinity of the booth.

5.05 If it becomes necessary to add this assembly to an existing booth, perform the following operations:

(1) Remove four wood screws and remove roof from booth.

(2) Mark the location for drilling a hole in ceiling in accordance with Fig. 6.

(3) Using a large expansive bit or equivalent, drill a 1-5/16 inch diameter hole in the position marked to a depth of approximately 1/8-inch.



... This 1-5/16 inch hole will accept the ring nut on the switch (Fig. 6).

(4) Complete the drilling of the hole through the ceiling using a 1/2-inch bit.



Use extreme care when the bit breaks through the ceiling to prevent splintering.

(5) Remove the cover from the receptacle housing of the sign control assembly.

(6) Secure the sign control assembly in the position shown in Fig. 7 with the switch plunger protruding through the hole drilled in (4).

(7) Secure the receptacle housing to the ceiling using two No. 10 by 3/8 RH wood screws.

(8) Connect the cable of the sign control assembly to the electrical receptacle (Fig. 7).

(9) Install the roof on the booth using four No. 9 by 1-inch FH wood screws.



Fig. 5 — KS-19340, List 56 Sign Control Assembly

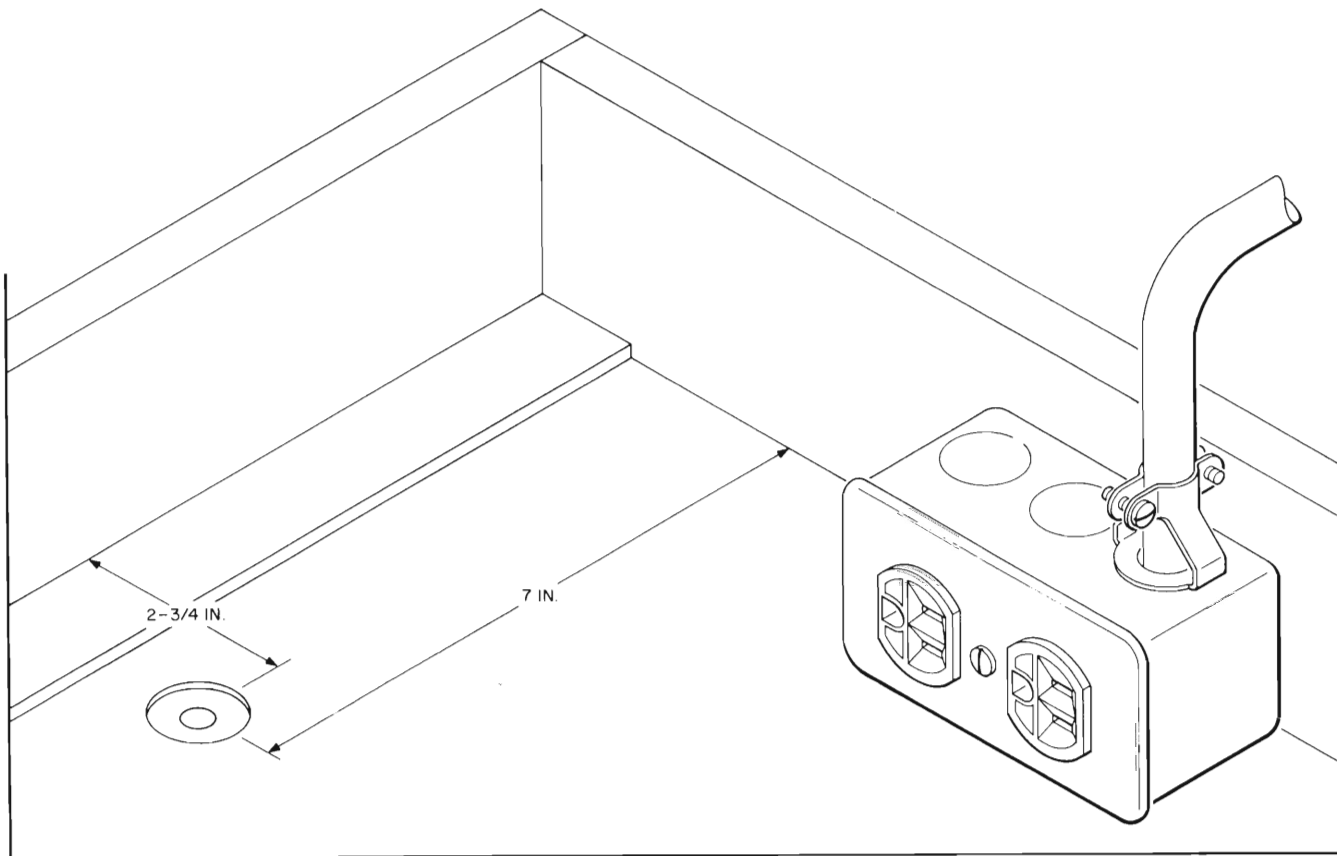

Fig. 6 — Location of Hole for Sign Control Assembly

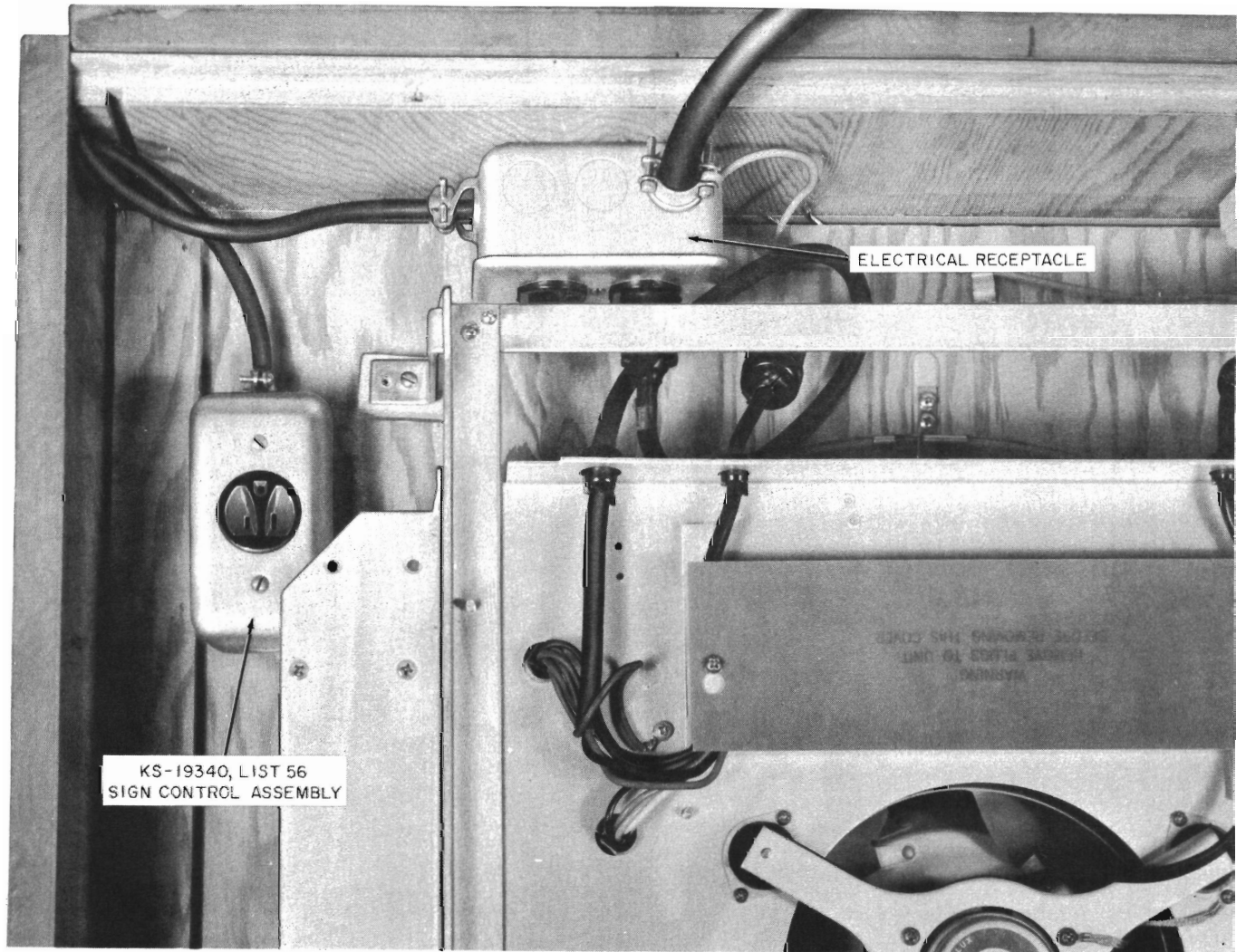

Fig. 7 — Location of Sign Control Assembly