

KEY EQUIPMENT—4A

COMMON BATTERY TALKING—COMMON BATTERY SIGNALING CONNECTIONS

1. GENERAL

1.01 This section contains connections for the 4A key equipment. Refer to SD-69087-01 for full schematics of components used in the system.



To minimize the possibility of crosstalk, the wiring between the subscriber set, 6026-type key, and dial should not exceed 10 feet. Avoid paralleling with other telephone wires.

1.02 This section is reissued to:

- Revise Fig. 3, 10, 11, and 12 to show factory strap between terminals 4 and 5 of 6026B key which is to be removed.

2. CONNECTION INDEX

Fig. 1—685A Subset and Rotary Dial, With Hold

Fig. 2—685A Subset and Rotary Dial, With or Without A Lead Control

Fig. 3—688C Subset and Rotary Dial, With Hold

Fig. 4—688A (MD) Subset and Rotary Dial, A Lead Control

Fig. 5—688B (MD) Subset and Rotary Dial, A Lead Control

Fig. 6—688C Subset and Rotary Dial, A Lead Control

Fig. 7—688C Subset and 1025A3 (MD) Dial, A Lead Control

Fig. 8—688C Subset and 1025W3A (MD) Dial, A Lead Control

Fig. 9—688C Subset and 1035C3A Dial, A Lead Control

Fig. 10—688C Subset and 1025A3 (MD) Dial, With Hold

Fig. 11—688C Subset and 1025W3A (MD) Dial, With Hold

Fig. 12—688C Subset and 1035C3A Dial, With Hold

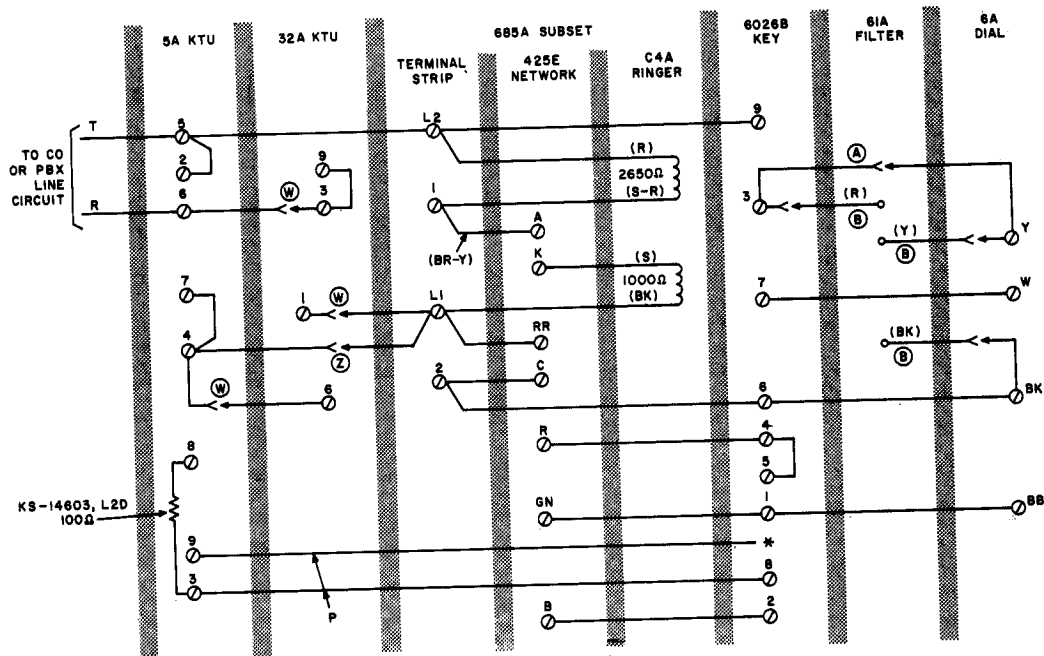

- * INSULATE AND STORE
- (W) LOOP LESS THAN 300 OHMS
- (Z) LOOP MORE THAN 300 OHMS
- (A) WITHOUT 61A FILTER
- (B) WITH 61A FILTER

Fig. 1—685A Subset and Rotary Dial, With Hold

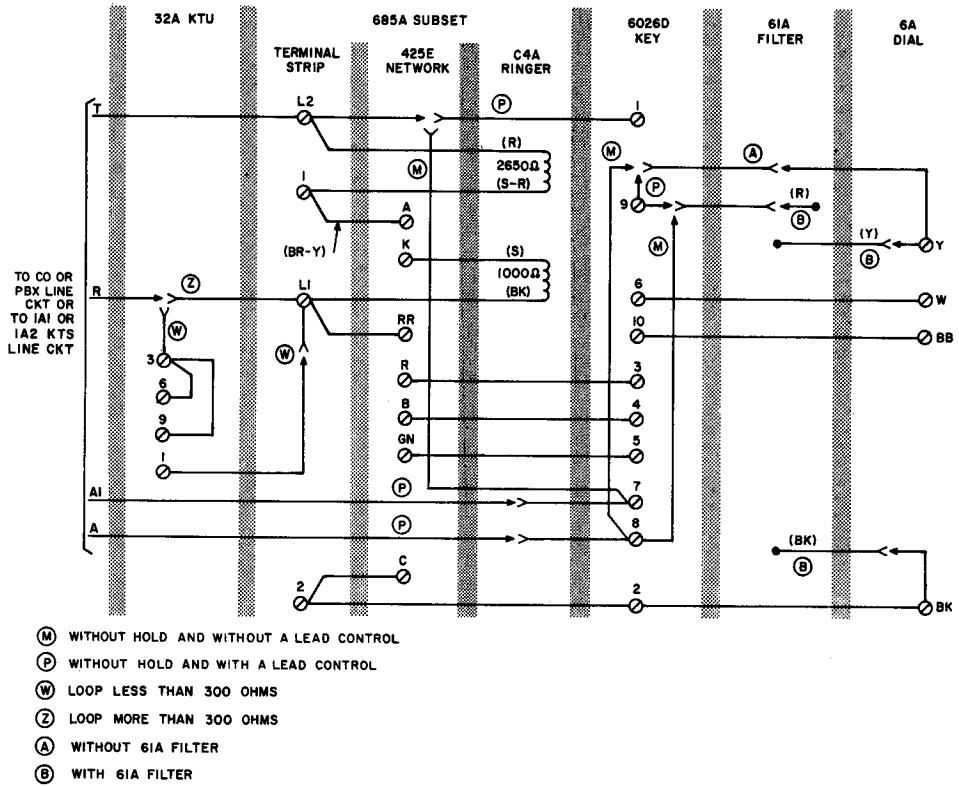

Fig. 2—685A Subset and Rotary Dial, With or Without A Lead Control

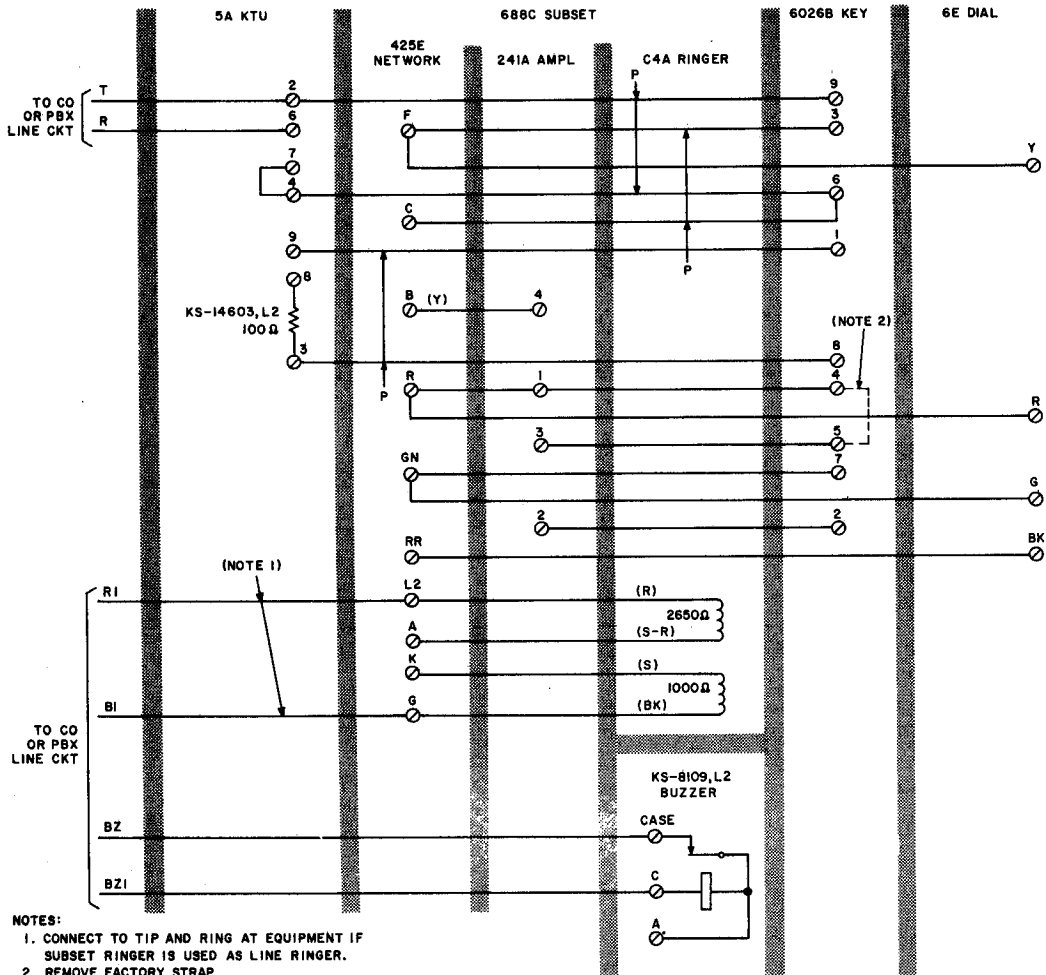
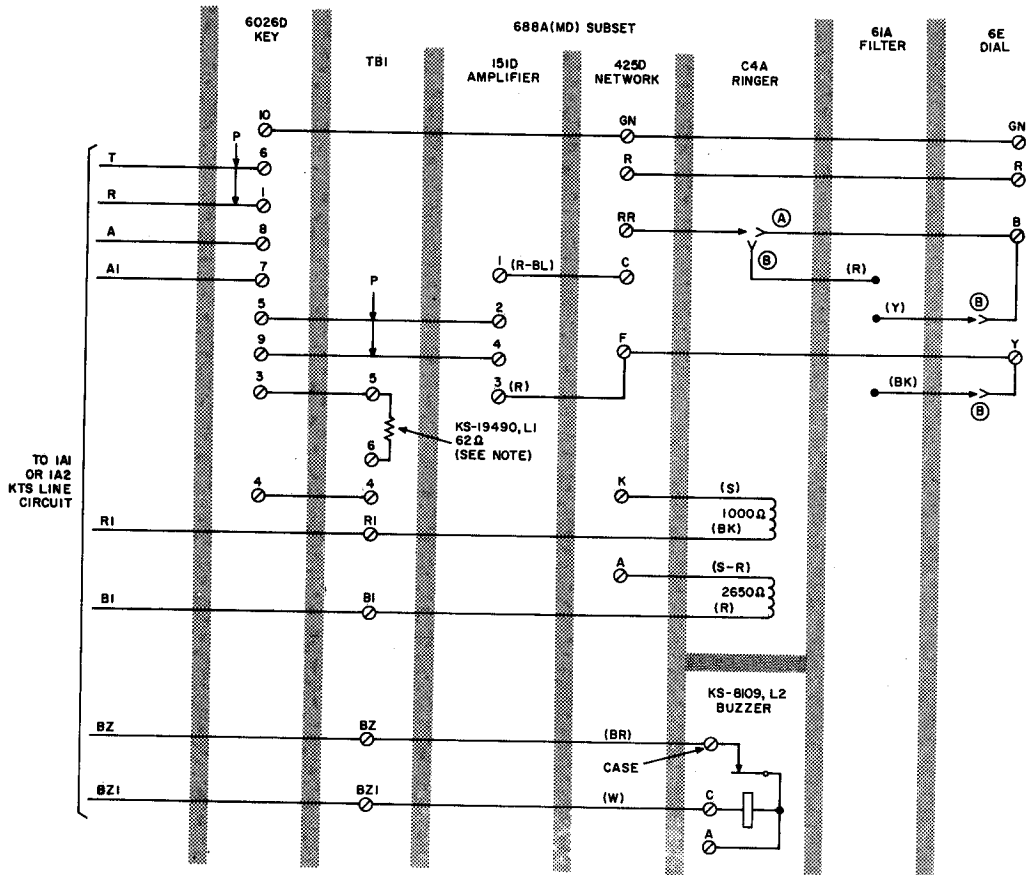

Fig. 3—688C Substation and Rotary Dial, With Hold



NOTE:
IF MORE TRANSMITTER GAIN IS REQUIRED,
REPLACE WITH A 30 OHM RESISTOR.

- (A) WITHOUT 61A FILTER
- (B) WITH 61A FILTER

Fig. 4—688A (MD) Subset and Rotary Dial, A Lead Control

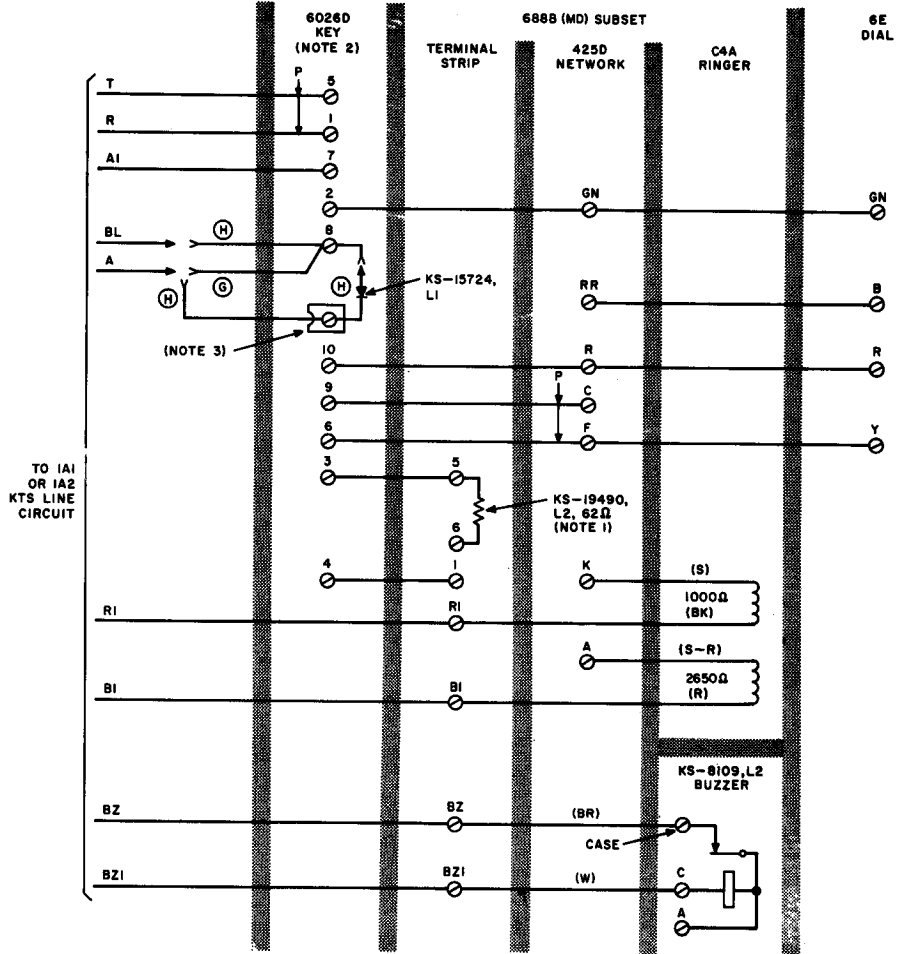

- NOTES:
1. IF MORE TRANSMITTER GAIN IS REQUIRED, REPLACE WITH 30Ω RESISTOR.
 2. MODIFY KEY BY MOVING (BK) SPADE-TIPPED LEAD CONNECTED TO VARISTOR FROM TERMINAL 3 TO 2.
 3. USE D-161488 CONNECTOR.
- ⓐ WITHOUT BUSY LAMP.
 ⓑ WITH BUSY LAMP.

Fig. 5—688B (MD) Subset and Rotary Dial, A Lead Control

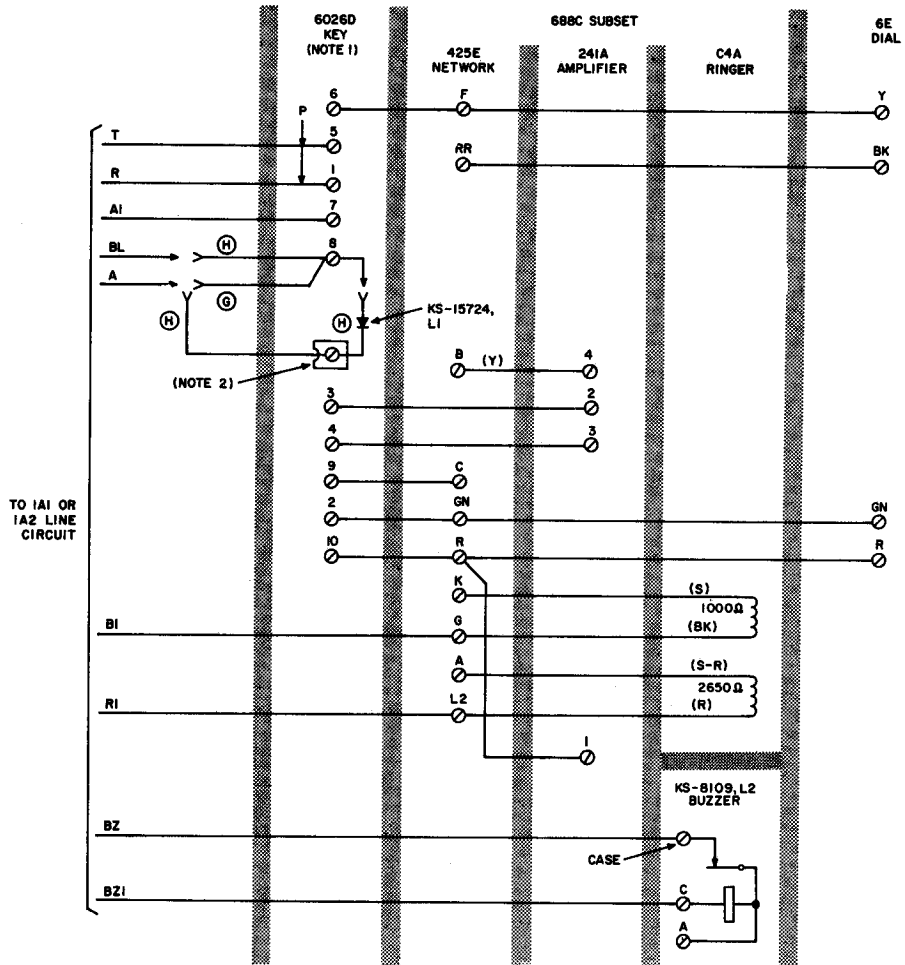

NOTES:

1. MODIFY KEY BY MOVING (BK) SPADE-TIPPED LEAD CONNECTED TO VARISTOR FROM TERMINAL 3 TO 2.
 2. USE D-161488 CONNECTOR.
- ⓐ WITHOUT BUSY LAMP
- ⓑ WITH BUSY LAMP

Fig. 6—688C Subset and Rotary Dial, A Lead Control

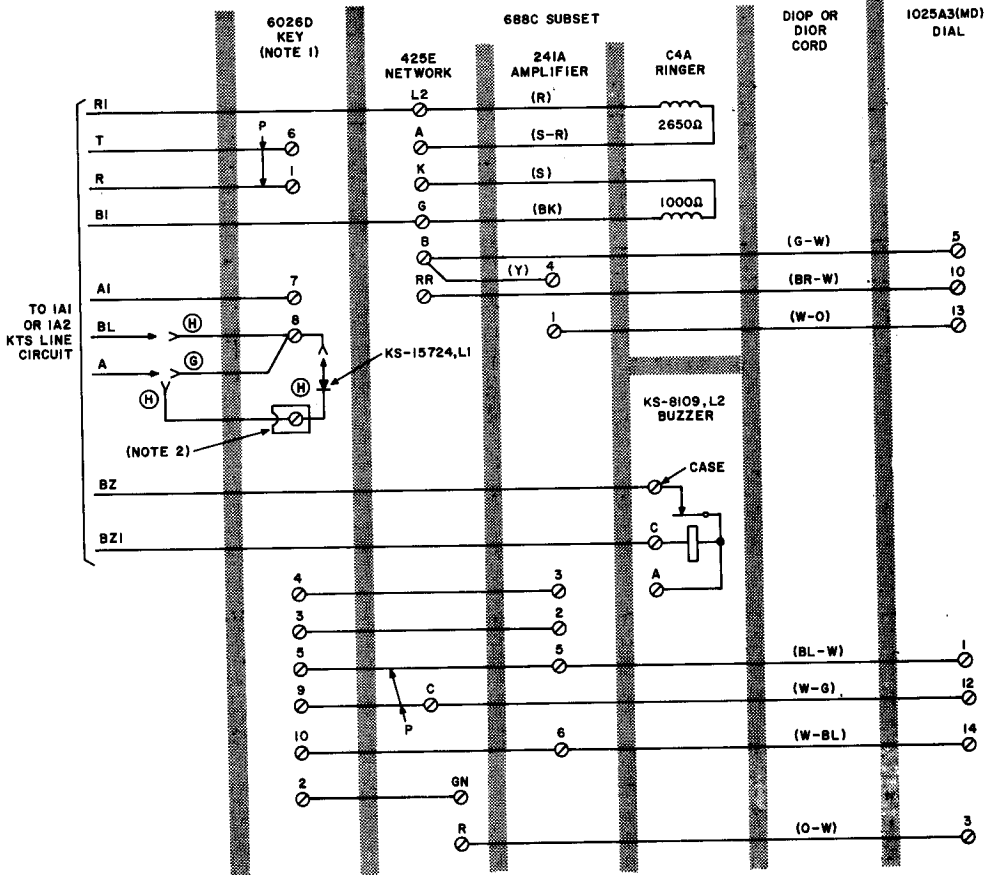

NOTES:

1. MODIFY KEY BY MOVING (BK) SPADE-TIPPED LEAD CONNECTED TO VARISTOR FROM TERMINAL 3 TO 2.
2. USE D-161488 CONNECTOR.

- (G) WITHOUT BUSY LAMP
- (H) WITH BUSY LAMP

Fig. 7—688C Subset and 1025A3 (MD) Dial, A Lead Control

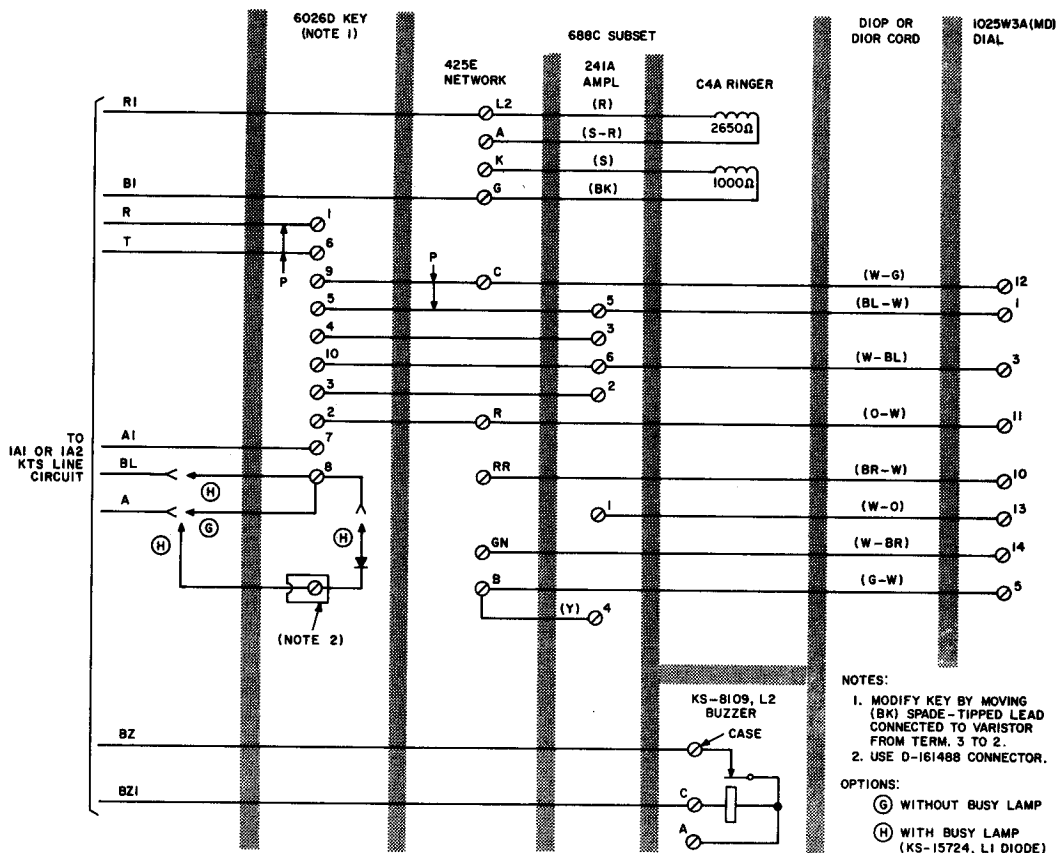

Fig. 8—688C Subset and 1025W3A (MD) Dial, A Lead Control

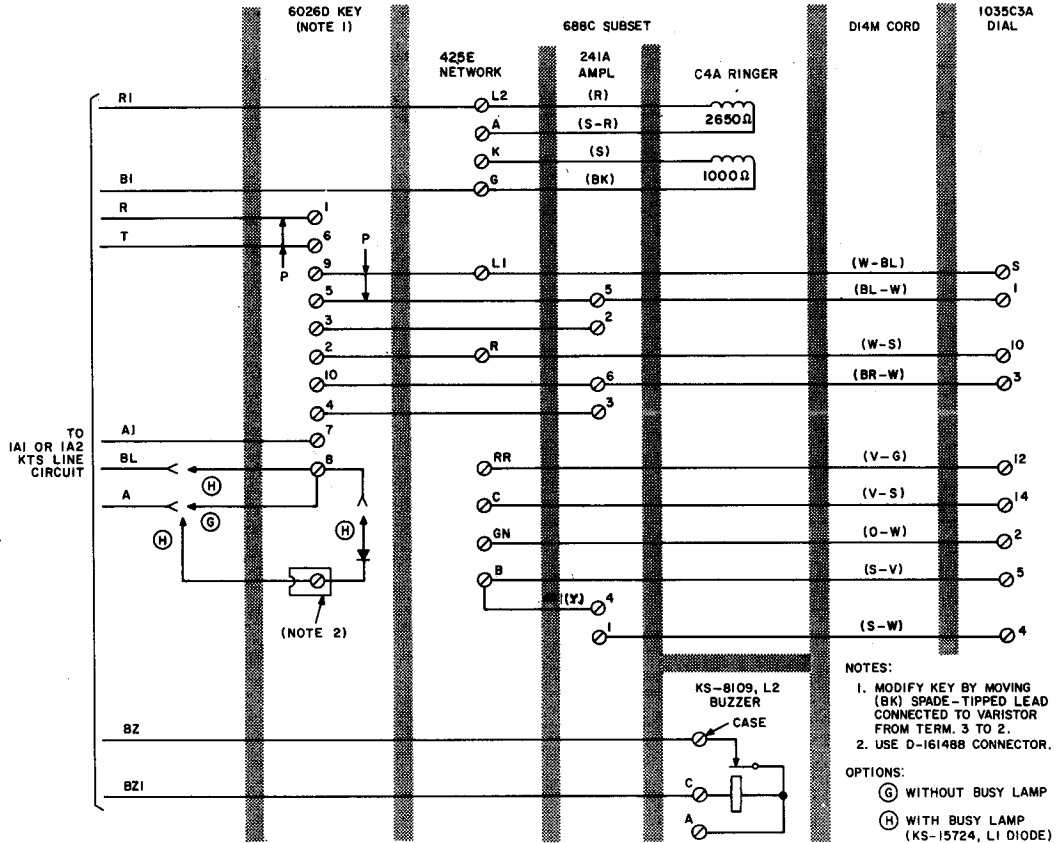

Fig. 9—688C Subset and 1035C3A Dial, A Lead Control

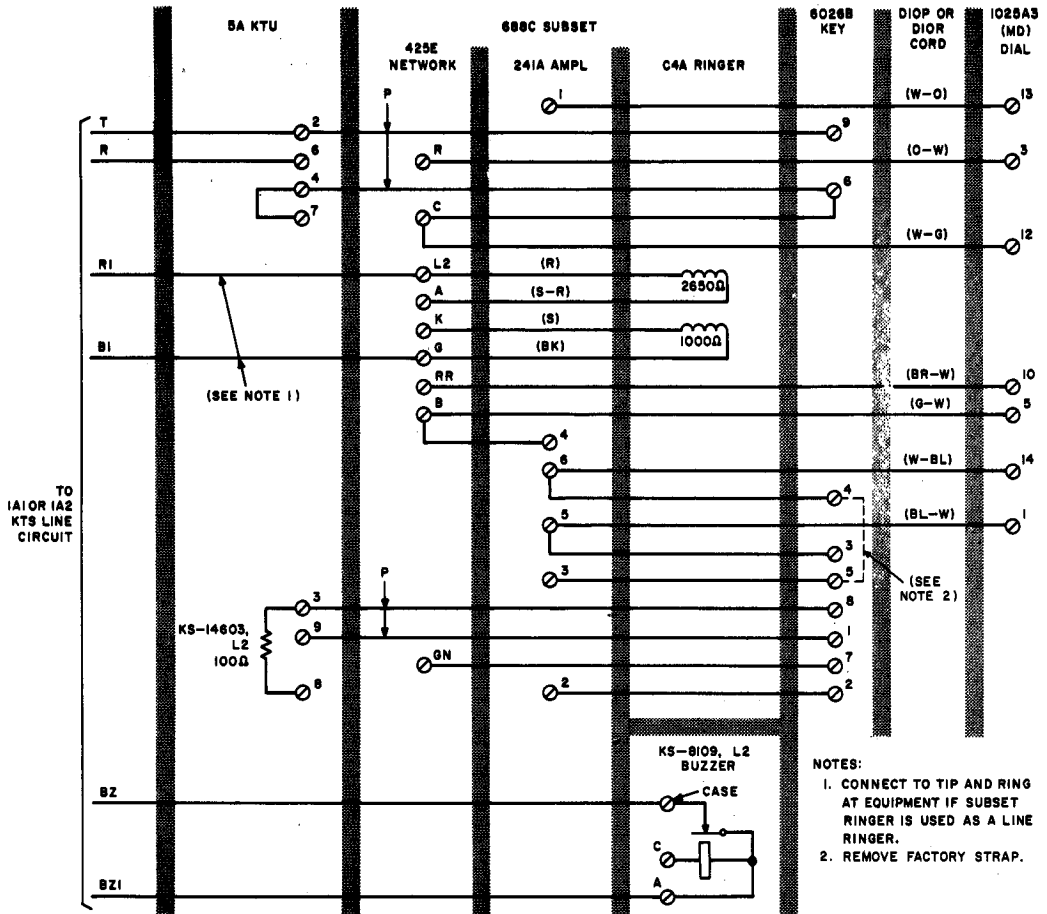

Fig. 10—688C Substation and 1025A3 (MD) Dial, With Hold

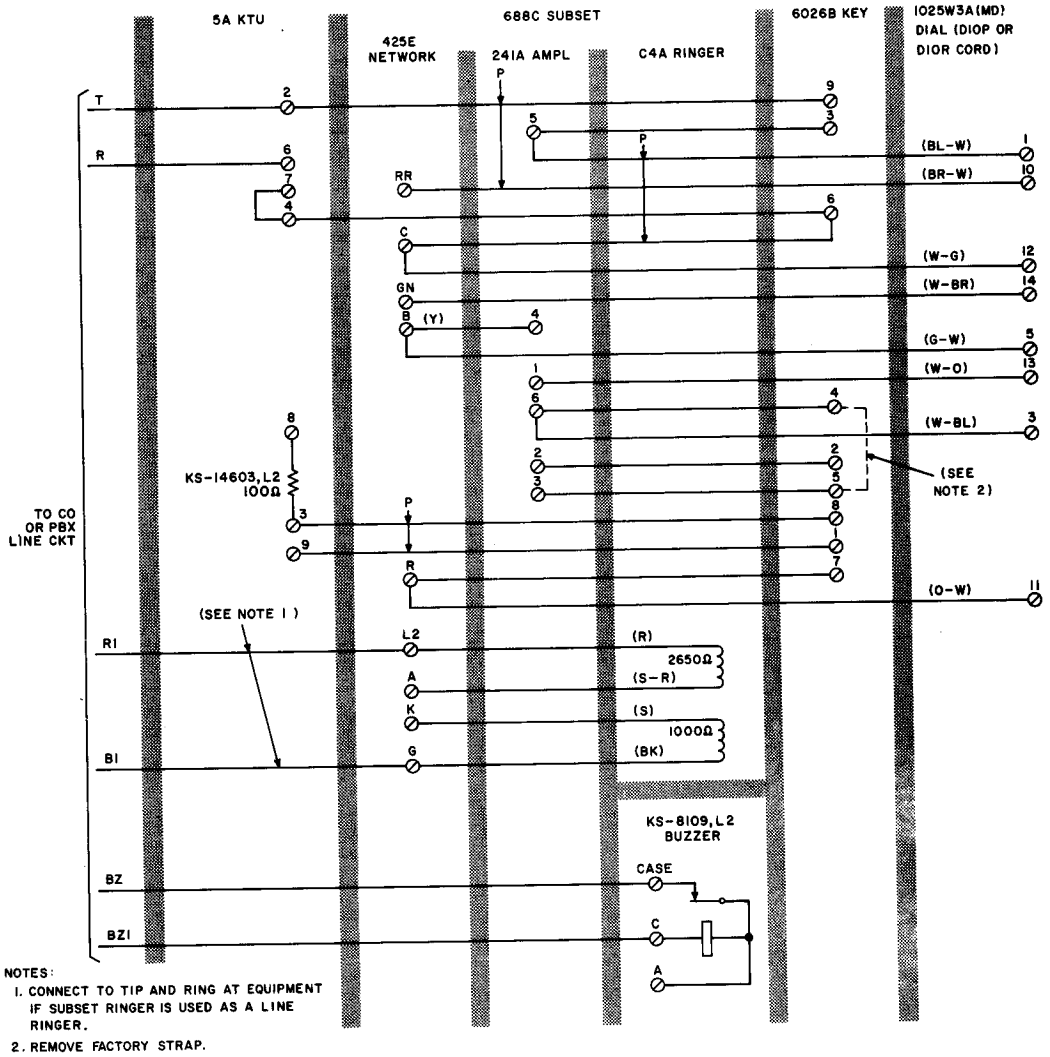

Fig. 11—688C Subset and 1025W3A (MD) Dial, With Hold

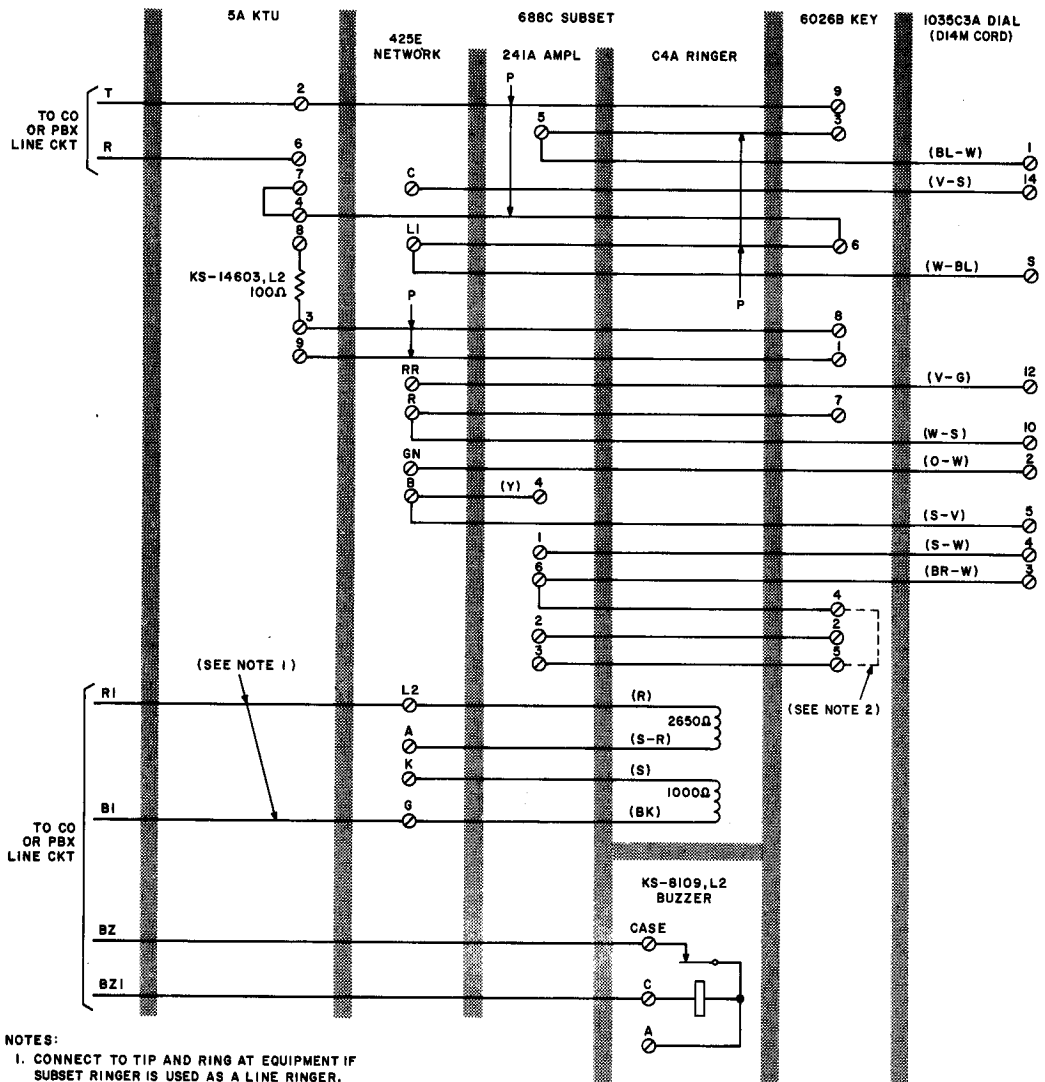

Fig. 12—688C Subset and 1035C3A Dial, With Hold