

## KS-16765, LISTS 1 AND 2 ANNOUNCEMENT SETS IDENTIFICATION AND MAINTENANCE

### 1. GENERAL

**1.01** Refer to CD- and SD-95286-01 for List 1 and CD- and SD-95283-01 for List 2 announcement sets.

**1.02** This section is reissued to emphasize the importance of regular lubrication and to add new lubrication requirements.

### 2. IDENTIFICATION

**2.01** The KS-16765, Lists 1 and 2 announcement sets (Fig. 1) feature:

- (a) Recording and reproducing of announcements on a magnetic recording band.
- (b) Announcement recording capacity of 2 minutes with provision for increasing to 3 minutes on most sets.



*Recording capacity of 3 minutes is provided on announcement sets with List 3 recorders. Announcement sets equipped with B-650412 drive assemblies, may be identified by a black star located at the upper right corner of the announcement set nameplate or identified by checking the serial number of the announcement set. All Lists 1 and 2 announcement sets having serial numbers higher than 22737 and 19395, respectively, can be arranged for 3-minute recording capacity by installing the B-650417 drive pulley. Sets without the black star and with serial numbers lower than 22737 and 19395, respectively, are limited to a 2-minute recording capacity.*

- (c) Adjustment for limiting announcement recording interval to less than maximum capacity.

- (d) Variable cycle that automatically adjusts reproduce cycle to length of recorded announcement.

**2.02** List 1 announcement set is designed and intended for:

- (a) Loop start operation.
- (b) Installation on a customers premises.
- (c) Remote control, up to several hundred feet, by either the pushbutton of a key telephone set or a 6040H or 6041H key with a 500-type telephone.

**2.03** List 2 announcement set is designed and intended for:

- (a) Ground start operation.
- (b) Central office installation or when used with a 2A, 2B, or 3A ACD installation on a customers premises
- (c) Local control using the dictate-check key on the announcement set with an operator telephone set plugged into the telephone jacks (Fig. 4).
- (d) Use with the KS-16765, List 7 mounting bracket and KS-16765, List 8 connecting cord if the set is to be mounted in a 23-inch relay rack.

**2.04** Lists 1 and 2 sets may be wall mounted or placed on a desk, table, or shelf.

**2.05** Each set weighs approximately 40 pounds and is housed in a metal cabinet that has a removable front and back (Fig. 2, 3, 4, and 5). The cover has a blue gray enamel finish and the chassis has a light olive gray finish. Dimensions are shown in Fig. 1.

### NOTICE

Not for use or disclosure outside the  
Bell System except under written agreement

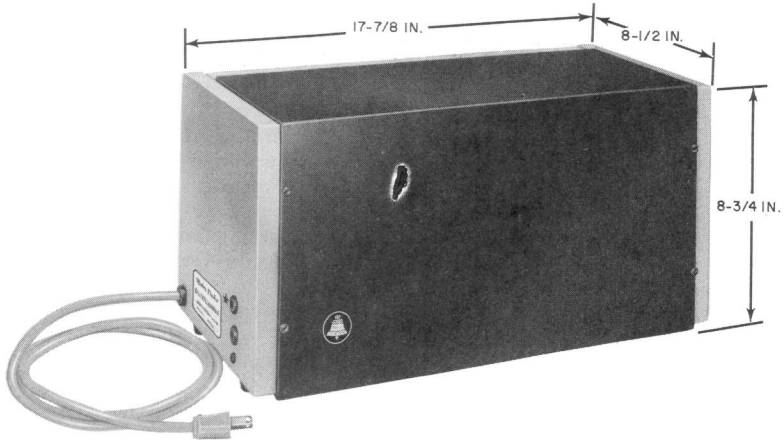

Fig. 1—KS-16765, Lists 1 and 2 Announcement Set Dimensions

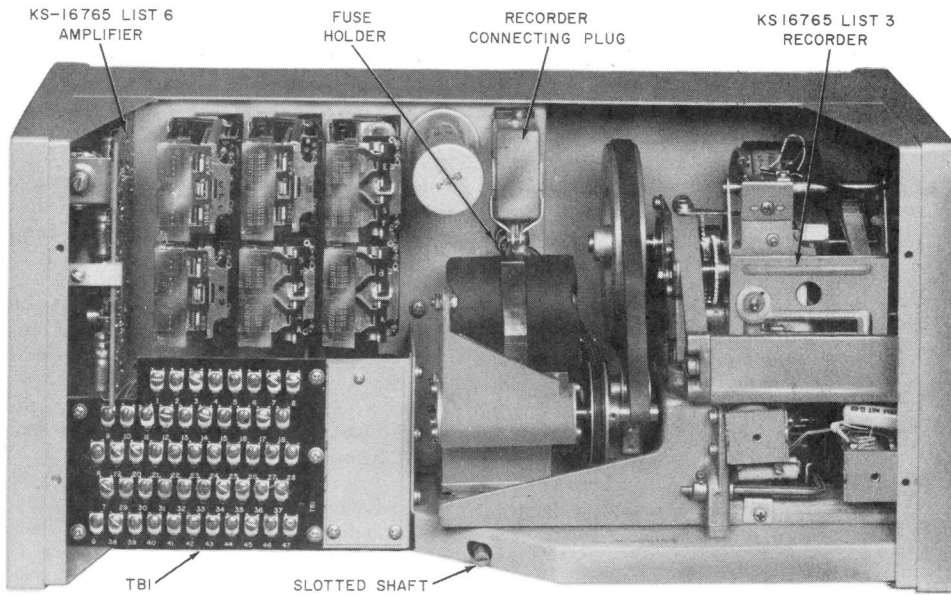

Fig. 2—KS-16765, List 1 Announcement Set, Front Cover Removed

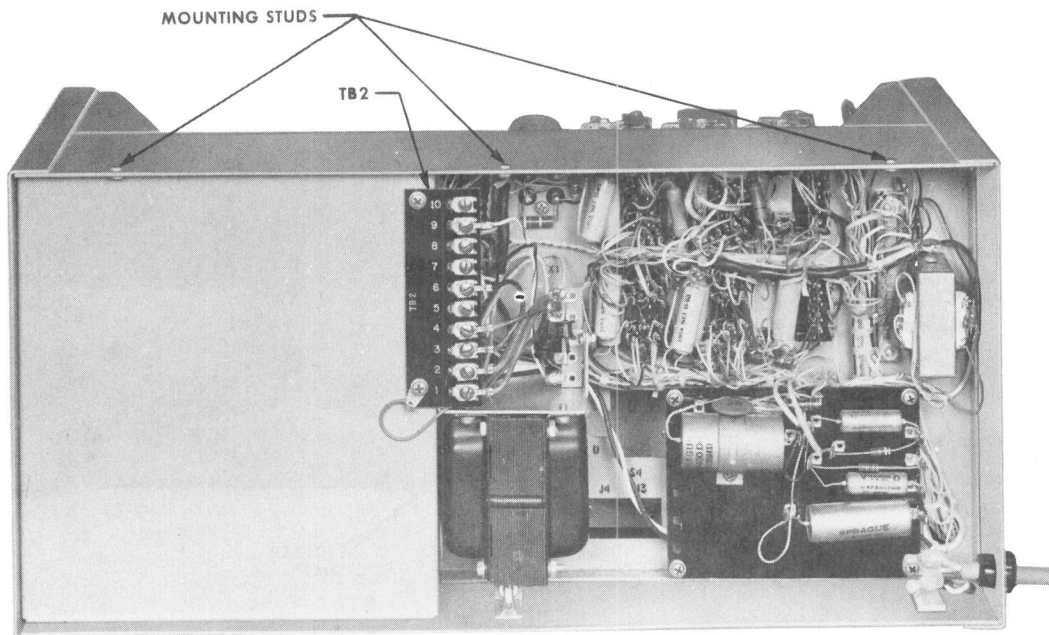

Fig. 3—KS-16765, List 1 Announcement Set, Rear Cover Removed

**2.06** A power source of 110/125-volt, 60 cycle ac is required for these sets. Outlet and power are provided by the customer.

**2.07** A 1/2-amp fuse is provided in these sets for electrical protection (Fig. 2 and 4).

**2.08** The KS-16765, Lists 1 and 2 announcement sets (Fig. 2, 3, 4, and 5) incorporate the following:

- KS-16765, List 3 Recorder
- KS-16765, List 6 Amplifier
- Chassis

**2.09** The KS-16765, List 3 recorder (Fig. 6 and 7) is the announcement recording mechanism. It consists of a magnetic record-reproduce head, an apparatus for tracking and switching, and a magnetic recording band on a drum. The drum is revolved by the B-650412 drive assembly (Fig. 10)

which is fitted with one of the two interchangeable pulleys that control the maximum recording duration.

**2.10** The B-650417 3-minute pulley (Fig. 8) is used to increase the maximum announcement recording capacity from 2 to 3 minutes. The 3-minute pulley reduces the angular speed of the recording drum, thereby increasing the announcement capacity.



*Earlier announcement sets without a black star beside the nameplate cannot be fitted with the 3-minute pulley and are limited to a recording duration of 2 minutes.*

**2.11** As shown in Fig. 8 the 3-minute pulley differs from the 2-minute in that the smaller diameter extension is not provided and hence, the flat drive belt is driven directly from the shaft.

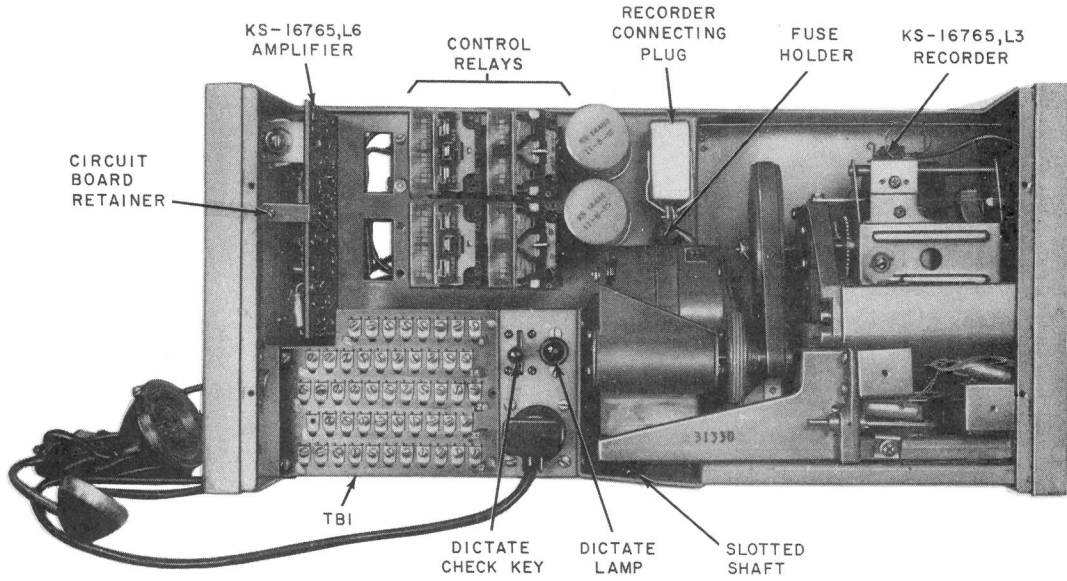

Fig. 4—KS-16765, List 2 Announcement Set, Front Cover Removed

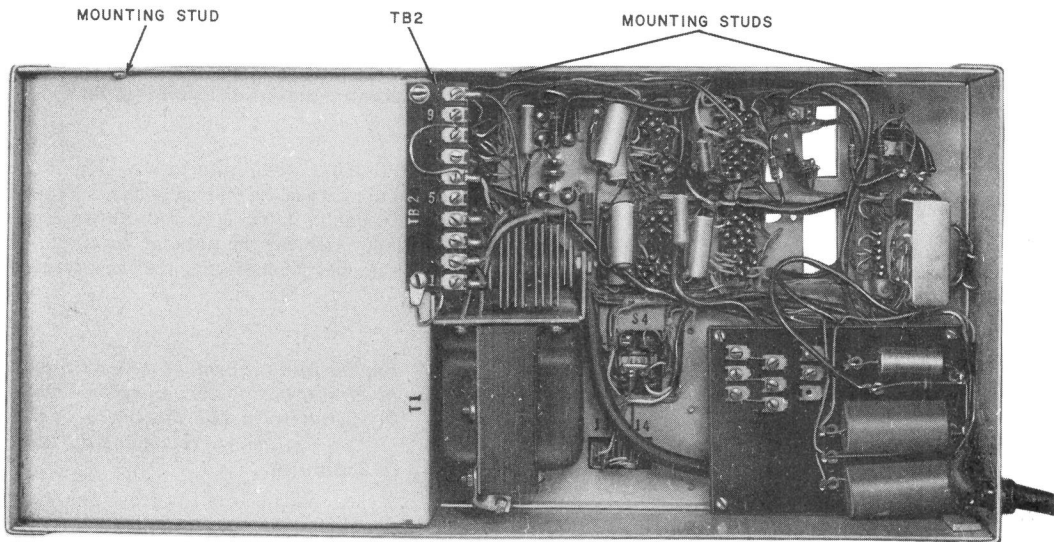

Fig. 5—KS-16765, List 2 Announcement Set, Rear Cover Removed

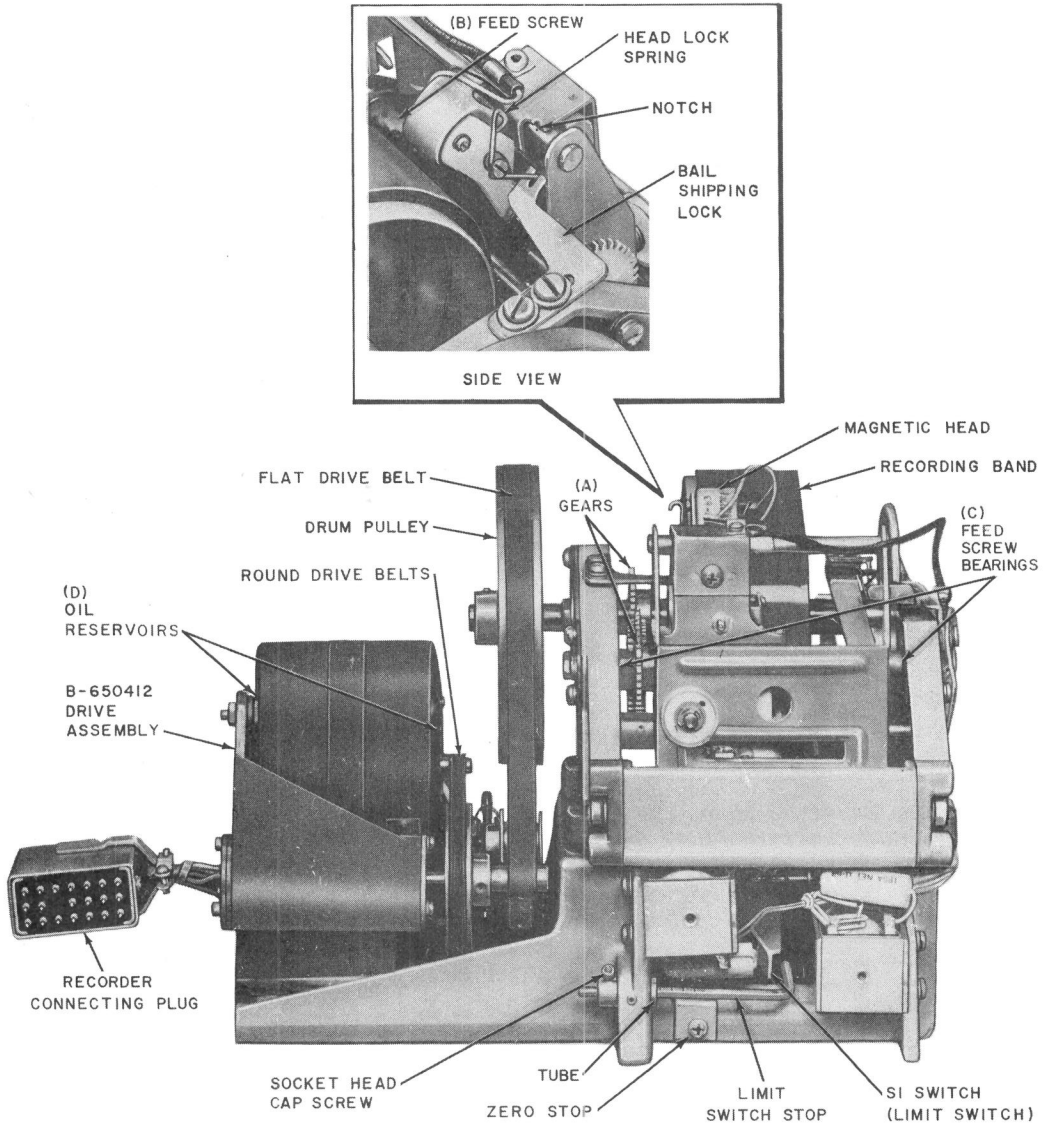

Fig. 6—KS-16765, List 3 Recorder, Front View

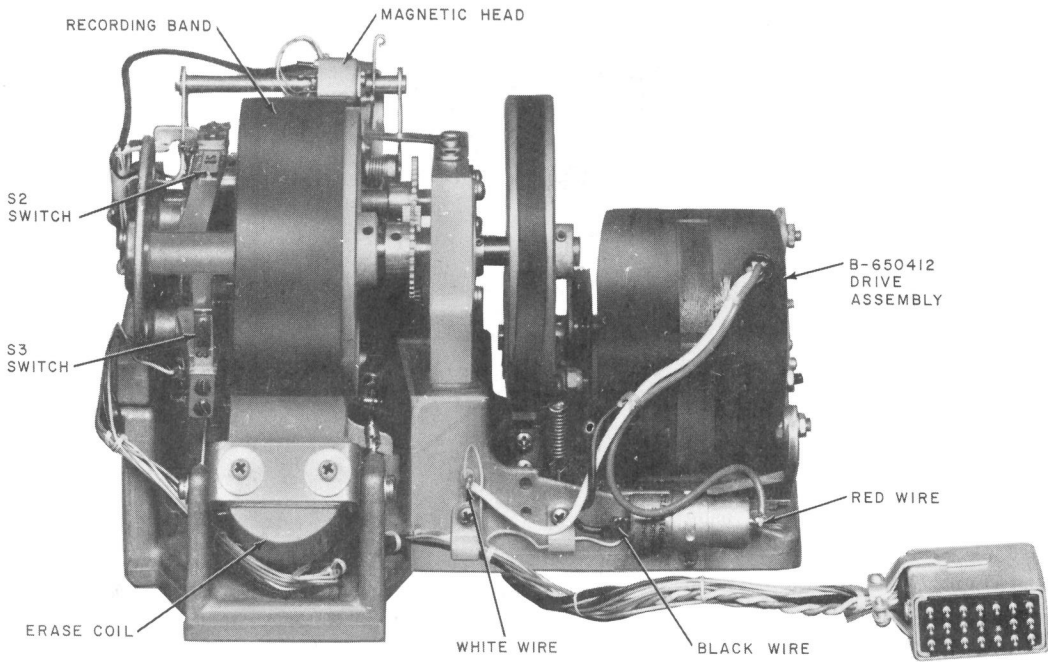

Fig. 7—KS-16765, List 3 Recorder, Rear View



*The B-650417 3-minute pulley is not furnished as part of the set and must be ordered separately.*

2.12 Facilities are provided for limiting the maximum recording interval to any portion of the total capacity. This is accomplished by adjustment of the limit switch stop (Fig. 6).

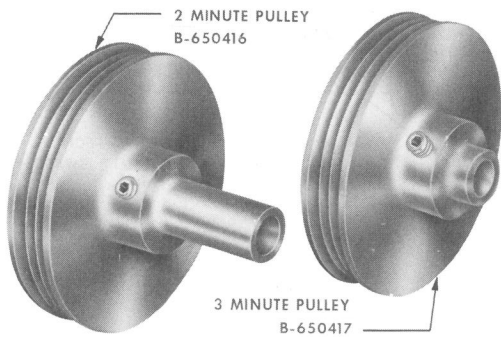

Fig. 8—Drive Pulleys



*The seven marks on the limit switch stop may be used as guides for setting the maximum recording interval.*

MARK	2-MINUTE CAPACITY TIME IN SEC.	3-MINUTE CAPACITY TIME IN SEC.
	(B-650416 PULLEY)	(B-650417 PULLEY)
1	0	0
2	15	22-1/2
3	30	45
4	45	67-1/2
5	60	90
6	90	135
7	120	180

**2.13** For intervals other than those shown, it will be necessary to estimate the setting between the two appropriate marks. The mark nearest the bent end of the stop (No. 1) represents 0 second.

**2.14** The KS-16765, List 6 amplifier (Fig. 9) is of printed wiring board construction and provides amplification for both recording and reproducing, an automatic volume control feature for minimizing variation in level of recorded speech, and a high frequency oscillator to provide the bias current required for magnetic recording. List 6 amplifier supersedes List 4 amplifier and may be used as a replacement in all Lists 1 and 2 announcement sets.



*Earlier type KS-16765, Lists 1 and 2 announcement sets are equipped with List 4 amplifiers. List 4 amplifier should not be used in List 1 sets with serial numbers above 8135 or in List 2 sets with serial numbers above 5558.*

**2.15** Earlier type KS-16765, Lists 1 and 2 announcement sets that have a 60 Hz hum in the output of the set, can be upgraded in the field with a kit of parts to reduce the hum level. This kit is to be ordered directly from the manufacturer. The kit of parts consists of a 10 ohm, 3 watt resistor and 750 ufd capacitor. Sets manufactured after the first quarter of 1971 are equipped with this modification. Installation information for this kit of parts is contained in the kit of parts package.

Ordering information for the modification kit is as follows:

(Qty) KS-16765 Filter Assembly Kit

Order directly from: Wilcox Electric, 14th and Chestnut Street, Kansas City, Missouri, 64127

Cost and shipping charges billed by manufacturer.

### 3. MAINTENANCE

**3.01** Work performed in customers' premises should be limited to:

- Verification and analysis of trouble
- Adjustments, lubrication, and cleaning as described in this section
- Replacement and repair of major components

**3.02** Requirements that are gauged by eye should be checked with gauges if there is any doubt.

**3.03** Refer to Table A for piece part information.

**3.04** Clean recording band and head on every maintenance visit.



*Before performing any maintenance on the set, disconnect power cord from the ac outlet.*

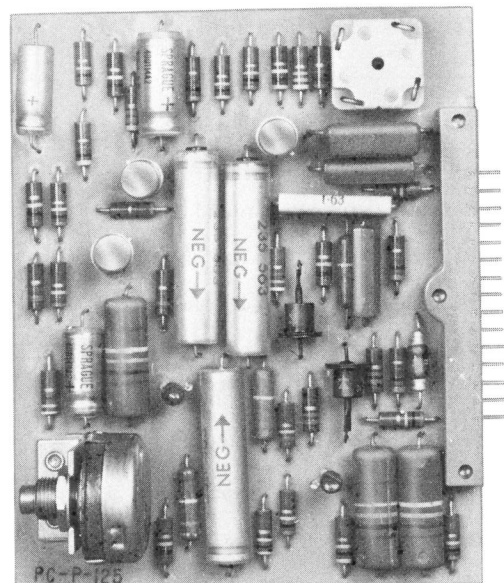

**Fig. 9—KS-16765, List 6 Amplifier**

TABLE A

PART	ORDERING INFORMATION	REMARKS	FIG.
Recorder	KS-16765, List 3	Announcement Mechanism	Fig. 4
Drive Assembly	B-650412	Component of KS-16765 List 3 Recorder	Fig. 6
Motor	B-650418	Component of B-650412 Drive Assembly	Fig. 6, 10
Drive Belt*	B-651981	Component of B-650412 Drive Assembly	Fig. 6, 10
Belt†‡	B-651703-1	Component of KS-16765, List 3 Recorder	Fig. 6
Belt	B-651703-2	Used on List 1 announcement sets equipped with KS-15914, List 1 or List 2 motors	
Pulley, 2-minute	B-650416	Component of B-650412 Drive Assembly	Fig. 8
Pulley, 3-minute	B-650417	Used to convert announcement set to 3-minute announcement interval	Fig. 8
Pulley Assembly	B-190932	"Idler Pulley Assembly"—Component of List 3 Recorder	Fig. 10
Spring	B-190920	"Idler Tension Spring"—Component of List 3 Recorder	Fig. 10
Stop	B-190915	Announcement Length Adjustment	Fig. 6
Amplifier	KS-16765, List 6	Printed Wiring Card for Recording and Reproducing	Fig. 9
Cover Assembly	B-190892	Front Cover of Announcement Set	Fig. 1
Cover, Rear	B-190890	Rear Cover of Announcement Set	
Fuse	AGC 1/2 amp; obtain locally	Provides Electrical Protection	Fig. 2, 4
Screw	B-190900	Captive screws of Front Cover Assembly	Fig. 1

\* Referred to in text as round drive belt.

† Referred to in text as flat drive belt.

‡ Furnished with B-650412 drive assembly.

**Note:** Parts identified by B-Number, Order As "B-....., part of KS-16765, List 1, 2 Announcement Sets."

#### REPLACEMENT OF MAJOR COMPONENTS

##### 3.05 KS-16765, List 3 recorder (Fig. 6 and 7):

- (1) Remove announcement set front cover.
  - Loosen four captive screws on front cover (Fig. 1).
  - Remove cover by sliding forward.
- (2) Remove recorder connecting plug from plug-in receptacle.

- (3) Remove List 3 recorder.
  - Remove three retaining screws located on bottom of announcement set.
  - Grasp recorder by its motor and chassis and carefully withdraw it from the cabinet.
- (4) Insert new recorder into cabinet.
  - Tighten three retaining screws.
- (5) Release bail shipping lock.
  - Loosen mounting screws.



- Move bail shipping lock to extreme position away from bail.
  - Position bail shipping lock to maintain adequate clearance between end of lock and head mounting bracket.
  - Tighten mounting screws.
- (6) Disengage head lock spring.
- Disengage head lock-spring from screw head located on the record-reproduce head.
  - Place head lock spring in notch on carriage bracket. Do not permit spring to rest on slide rod.
- (7) Adjust announcement record capacity as described in 3.22.
- (8) Insert recorder connecting plug into plug-in receptacle.
- (9) Replace announcement set cover and tighten four captive screws.

**3.06 KS-16765, List 6 amplifier (Fig. 2, 4, and 9):**

**Caution: Do not remove or plug in List 4 or 6 amplifier while power is on. Failure to observe this precaution may cause failure of or damage to electron tube filaments.**

- (1) Remove announcement set cover (3.05).
- (2) Remove List 6 amplifier.
  - Loosen retaining screw of circuit board retainer.
  - Carefully remove amplifier from its plug-in receptacle.
- (3) Insert new amplifier into plug-in receptacle, tighten screw of circuit board retainer.
- (4) Replace announcement set cover.
  - Tighten four captive screws.



**Earlier type KS-16765, Lists 1 and 2 announcement sets are equipped with List 4 amplifiers. Faulty List 4 amplifiers may be replaced in these sets with either List 4 or List 6 amplifier. List 6 amplifier can be used in all KS-16765, Lists 1 and 2 announcement sets. List 4 amplifier can only be used in List 1 sets with serial number 8135 or lower and in List 2 sets with serial number 5558 or lower.**

**3.07 Power Supply—Modification to Reduce 60 Hz Hum Level:**

**Caution: Remove power cord before performing any work on the power supply to prevent shock and damage to equipment.**

- (a) Complete installation procedure is included with the kit of parts for both List 1 and List 2 announcement sets. A complete schematic of the power supply will be found in SD-95286-01 and SD-95283-01 for the KS-16765, Lists 1 and 2 sets, respectively.

**3.08 Relays and Fuses (Fig. 2 and 4):** Relays in these announcement sets shall be maintained and adjusted in accordance with Division 040 of the Plant Series covering wire spring relays.

**3.09** Circuit requirement table for these relays is included in SD-95286-01 and SD-95283-01.

**3.10** Faulty relays will necessitate replacement of the announcement set.

**3.11** The line fuse provided for this set is mounted just below the recorder connector plug (Fig. 2 and 4). The set is equipped with a 1/2-amp AGC fuse. Sets equipped with 1 ampere AGC fuse will be changed to the 1/2 ampere AGC fuse. For fuse inspection or replacement, remove recorder connector plug from receptacle, turn fuse holder counterclockwise and withdraw.

**3.12 B-650412 Drive Assembly (Fig. 10):**

- (1) Remove announcement set cover (3.05).
- (2) Remove List 3 recorder (3.05).
- (3) Remove flat drive belt.

- (4) Remove drive assembly.
  - Unsolder motor leads.
  - Remove four Phillips head screws located on bottom of casting.
  - Lift out drive assembly.
- (5) Remove idler pulley assembly, tension spring and associated nut, washers and details. Install these items on the new B-650412 drive assembly (Fig. 10).
- (6) Install new drive assembly.
  - Tighten four Phillips head screws.

- Solder motor leads (Fig. 7).

- (7) Install flat drive belt (3.17).



***Before securing List 3 recorder to cabinet, energize recorder and run to observe that flat drive belt runs squarely on drum pulley and does not slip or bind.***

- (a) If belt runs to either side of pulley, correct by loosening mounting screws and pivoting idler pulley assembly. Tighten mounting screws after adjusting.
- (b) If belt slips or binds, correct by moving idler tension spring to another hole on idler pulley arm.

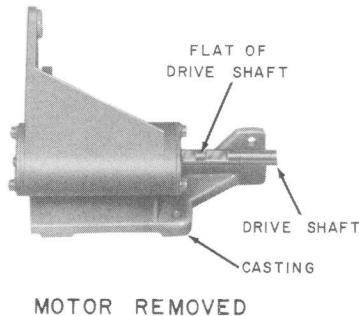
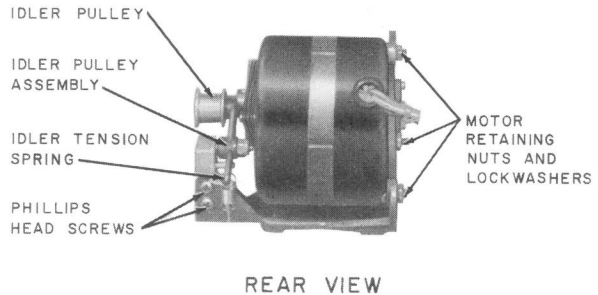
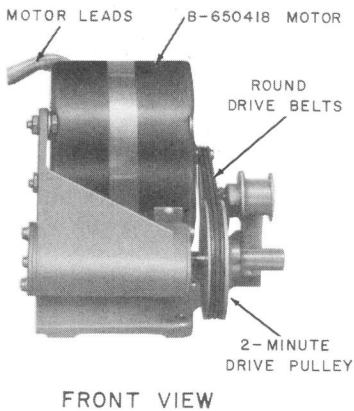

**Fig. 10—B-650412 Drive Assembly**

- (8) Insert List 3 recorder into cabinet.
- Tighten three retaining screws.
- (9) Insert recorder connecting plug into plug-in receptacle.
- (10) Replace announcement set cover.
- Tighten four captive screws.

### 3.13 **Motor Replacement (Fig. 10):**

- (1) Remove List 3 recorder (3.05).
- (2) Remove flat drive belt.
- (3) Remove drive assembly.
- Unsolder motor leads.
  - Remove four Phillips head screws located on bottom of casting.
  - Lift out drive assembly.
- (4) Remove three round drive belts from motor shaft and drive pulley.
- (5) Disengage idler tension spring.
- (6) Remove idler pulley assembly.
- Remove two Phillips head screws located on mounting bracket.
- (7) Remove 2-minute drive pulley (Fig. 8).
- Loosen set screw located on collar of pulley.
  - Slide pulley off drive shaft.
- (8) Remove motor.
- Remove three nuts and lock washers.
  - Lift off motor.
- (9) Install new motor.
- Tighten three nuts and lock washers.
- (10) Replace 2-minute drive pulley (Fig. 8).

- Insert pulley on shaft.
- Align pulley with motor shaft.
- Tighten set screw.

**Note:** Tighten set screw against the flat of the drive shaft.

- (11) Install three round drive belts (3.18).
- (12) Replace idler pulley assembly.
- Tighten two Phillips head screws.
- (13) Engage idler tension spring.
- (14) Install drive assembly.
- Tighten four Phillips head screws.
  - Solder motor leads (Fig. 7).
- (15) Install flat drive belt, and observe the **Read** (3.17).
- (a) If belt runs to either side of pulley, correct by loosening mounting screws and pivoting idler pulley assembly. Tighten mounting screws after adjusting.
- (b) If belt slips or binds correct by moving idler tension spring to another hole on idler pulley arm.
- (16) Insert List 3 recorder in cabinet.
- Tighten three retaining screws.
- (17) Insert recorder connecting plug into plug-in receptacle.



**Earlier type announcement sets are equipped with KS-15914, List 1 or 2 motor. Faulty List 1 or 2 motor may be replaced with B-650412 drive assembly:**

### 3.14 **To install B-650412 drive assembly:**

- (1) Remove List 3 recorder (3.05).
- (2) Remove flat drive belt and discard.

- (3) Remove motor assembly.
    - Unsolder motor leads (Fig. 7).
    - Remove four Phillips head screws located on bottom of casting.
    - Lift out motor.
  - (4) Remove idler pulley assembly, tension spring and associated nut, washers and details. Install these items on the B-650412 drive assembly.
  - (5) Install B-650412 drive assembly.
    - Tighten four Phillips head screws.
    - Solder motor leads (Fig. 7).
  - (6) Install B-651703-1 flat drive belt, and observe the **Read** (3.17).
    - (a) If belt runs to either side of pulley, correct by loosening mounting screws and pivoting idler pulley assembly. Tighten mounting screws after adjusting.
    - (b) If belt slips or binds, correct by moving idler tension spring to another hole on idler pulley arm.
  - (7) Insert List 3 recorder into cabinet.
    - Tighten three retaining screws.
  - (8) Insert recorder connecting plug into plug-in receptacle.
- (3) Remove three round drive belts.
  - (4) Remove drive assembly.
    - Remove four Phillips head screws located on bottom of casting.
    - Lift out drive assembly.
  - (5) Disengage idler tension spring.
  - (6) Remove 2-minute drive pulley.
    - Loosen set screw located on collar of pulley.
    - Slide pulley off shaft.
  - (7) Install 3-minute pulley:
    - Insert pulley on drive shaft.
    - Align pulley with motor shaft.
    - Tighten set screw against the flat of the drive shaft.
  - (8) Install drive assembly.
    - Tighten four Phillips head screws.
  - (9) Install flat drive belt, and observe the **Read** (3.17).
  - (10) Insert List 3 recorder into cabinet.
    - Tighten three retaining screws.
  - (11) Insert recorder connecting plug into plug-in receptacle.

### 3.15 B-650417, 3-Minute Pulley (Fig. 8):



*KS-16765, Lists 1 and 2 announcement sets equipped with B-650412 drive assemblies may be converted from 2-minute announcement recording capacity to 3-minute by installing the B-650417, 3-minute pulley.*

### 3.16 Procedure for converting:

- (1) Remove List 2 recorder (3.05).
- (2) Remove flat drive belt.

### Belt Replacement



*Replace belts if they are broken, cracked, nicked, stretched, or have oil or grease on their surfaces.*

### 3.17 Flat Drive Belt:

- (1) Remove faulty flat drive belt from drum pulley and drive pulley shaft.
- (2) Install new flat drive belt with unground (shiny) side in contact with the drum pulley,

on center of drum pulley, and so that edges of belt will not ride up on the flanges of the idler pulley (Table A).



**Before securing List 3 recorder to cabinet, energize recorder and run to observe that flat drive belt runs squarely on drum pulley and does not slip or bind.**

**Note:** Flat rubber drive belts B-651703-1 for use with B-650412 drive assembly (Part of List 3 recorder) are larger in diameter than belts B-651703-2 used with KS-15914 (MD), List 1 or 2 motor (Part of List 3 recorder).

### 3.18 Round Drive Belt:

- (1) Remove flat drive belt from drum pulley and drive pulley shaft.
- (2) Remove faulty round drive belt.
- (3) Install new round drive belt.
  - Verify that drive belts are parallel with each other between the motor shaft and drive pulley.
- (4) Install flat drive belt, and observe *Read* (3.17).

### MECHANICAL ADJUSTMENTS (Fig. 6 and 7)

#### 3.19 Zero Position of Carriage Assembly:

Position where the side of the carriage nearest the motor is in contact with the adjacent side of the bail assembly with the bail assembly in the unoperated position.

**3.20 Zero Position of the Limit Switch:** Position where the limit switch lever is in contact with the zero stop with the carriage assembly in the zero position.

**3.21 Magnetic Head in the Electrically Operated Position:** Position where the magnetic head is in contact with the surface of the recording band and the half nut and feed screw of the carriage assembly are engaged.

**Note:** To engage magnetic head in the electrically operated position, carefully rotate drum pulley by hand to position where switch

3 is operated. Supply 48 volts dc to pins 7 (-) and 14 (+) of connecting plug of List 3 recorder.

#### 3.22 Announcement Length Adjustment (Fig. 6):

The announcement set is shipped with the announcement length adjusted for 30 seconds, however this adjustment may be set for an interval up to the maximum capacity by adjustment of the limit switch stop. The seven marks on the limit switch stop may be used as guides for setting the maximum announcement recording interval. For intervals other than those shown, it will be necessary to estimate the setting between the two appropriate marks. The mark nearest the bent end of the stop (No. 1) represents 0 seconds. To change announcement record interval, proceed as follows:

- (1) Loosen socket head cap screw.
- (2) Position the limit-switch stop to desired setting, desired setting should be flush with left side of tube.
- (3) Tighten socket head cap screw.

#### 3.23 Switch Springs (S1, S2, and S3) (Fig. 6 and 7):

##### (a) Contact separation and follow:

- (1) In the unoperated position, S1 switch contacts shall have a separation between contacts of:

Min. 0.008 inch

Max. 0.015 inch

Gauge by eye

- (2) In the unoperated position, S2 and S3 switch contacts shall have a separation between contacts of:

Min. 0.006 inch

Max. 0.015 inch

Gauge by eye.

- (3) When S2 and S3 switches are operated by the insulated pin of the drum, the contact follow shall be:

Min. 0.010 inch

Max. 0.020 inch

Gauge by eye.

- (4) Contact separation and follow of these springs are interdependent. Care should be taken when adjusting to meet one requirement that the other is also met. Adjustments should be made using the No. 534E spring adjuster on the stationary springs, and the No. 524A or No. 524B spring adjuster on the operating springs. To adjust, place the adjuster on the spring and slide it back to where the spring leaves the insulator. Adjust the spring up or down as required.

(b) **Contact alignment (Fig. 11):**

- (1) The contacts shall line up so that the width on the contact surface of each contact bar falls wholly within the length of its mating bar.

Gauge by eye.

- (2) If any switch fails to meet the contact alignment requirement, replace List 3 recorder.

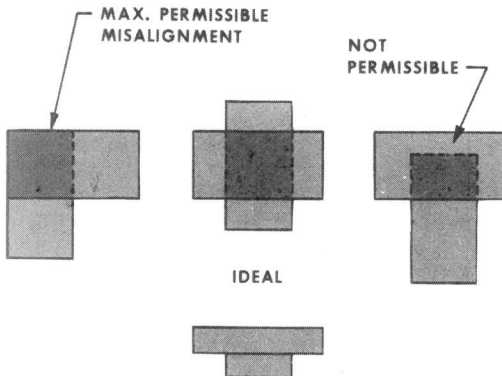

**Fig. 11—Contact Alignment**

- 3.24 Erase Coil (Fig. 12):** The erase coil assembly shall be so positioned that the central plane of the pole piece gap is radial with respect to the recording band. Gauge by eye.

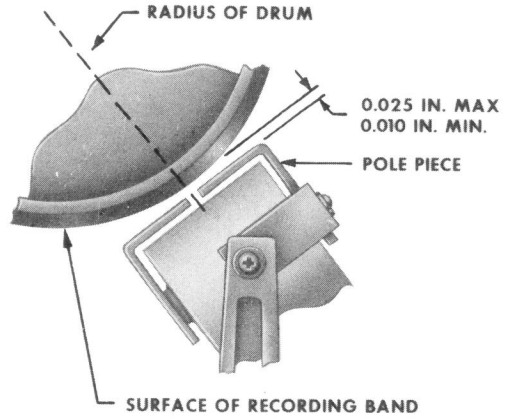

**Fig. 12—Erase Coil Clearance**

(a) **To adjust pole piece:**

- (1) Loosen the 3 screws that fasten the pole piece bracket to the base.
- (2) Adjust erase coil forward or backward to correct position.
- (3) Tighten screws.

There shall be a clearance between the recording band and the surface of the erase coil pole pieces throughout one complete revolution of the drum of:

Min. 0.010 inch

Max. 0.025 inch

Gauge by eye.

(b) **To adjust separation:**

- (1) Loosen the two screws that fasten erase coil to bracket.

- (2) Move erase coil either toward or away from drum to correct position.
- (3) Keep same separation over the width of the drum.
- (4) Tighten screws after making adjustment.

### 3.25 *Magnetic Head Lifter Tab Position (Fig. 13):*

With magnetic head in electrically operated position, the clearance between the magnetic head bracket and the tab shall be a minimum of 1/32-inch. Gauge by eye. (Fig. 13A). With magnetic head in electrically operated position, the clearance between the magnetic head and the tab shall be a minimum of 1/32 inch. Gauge by eye, (Fig. 13B). With the magnetic head unoperated, the clearance between the magnetic head and the recording band shall be a minimum of 1/32 inch. Gauge by eye. Head lifter tab may be bent to meet these requirements. Use No. 325 adjuster. **Do not damage wiring.**

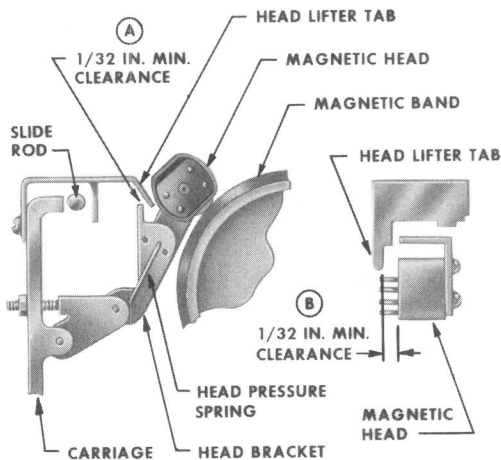

Fig. 13—Head Lifter Tab Clearance

**3.26 Carriage:** The carriage assembly shall return freely and without hesitation to its starting position.

**Note:** Check this requirement in several positions, one of which is close to the zero position of the carriage.

Head retainer shipping lock spring shall be in the notch provided on the carriage and should not bear on the slide rod.

### 3.27 *Limit Switch:*

- (a) Replace recorder if:
  - Limit switch does not return freely to its zero position when limit switch arm is released by operation of L2 solenoid.
  - Message is clipped on reproduce.

**3.28 Magnetic Head Pressure (Fig. 14):** With the magnetic head in the electrically operated position, the pressure of the magnetic head on the recording band shall be a minimum of 28 grams, a maximum of 43 grams. Use No. 68B gauge to measure this quantity by placing tip of gauge under recording head bracket between the two mounting screws and measuring the pressure on a line passing through the drum center and between the two screws. The end of the head pressure spring shall be placed in the hole which provides the maximum pressure within the permissible range.

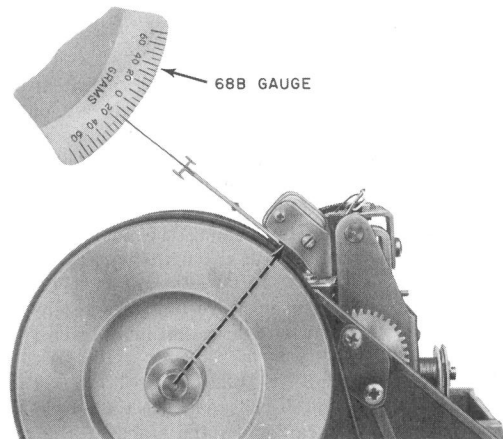

Fig. 14—Magnetic Head Pressure

**3.29 Bail Stop Position (Fig. 15):** With the magnetic head in the electrically operated position, the clearance between the side of the slot in the bail assembly and the side of the bail stop

farthest from the drum shall be 1/32-inch minimum throughout the entire carriage travel. If the clearance between the bail stop and bail assembly in the operated position is not satisfactory, adjust the bail stop as required by using the No. 325B adjuster to bend the bail stop. Check clearance with the 92K feeler gauge. This requirement should be checked everytime the recorder is lubricated.

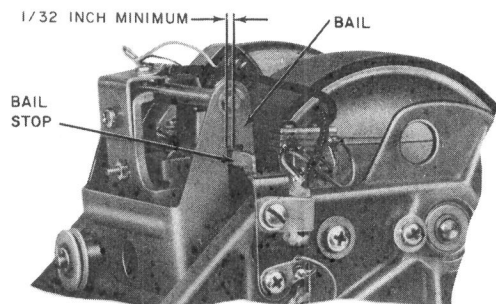

Fig. 15—Bail Stop Adjustment

## LUBRICATION

**3.30** The life and continued proper operation of the announcement set is dependent upon a well administered and properly executed lubrication program. Therefore, it is critically important that before being placed in operation, the announcement set shall have been lubricated as specified and that after being placed in service, the set must be lubricated every three months with the KS-16326, List 1 oil and KS-19139, List 4 lubricant as specified in 3.37. Experience may prove that sets receiving severe service may need lubricating more often.

**3.31** One drop of KS-16326, List 1 oil is the amount of oil discharged from the nozzle of the No. 486A oil can when the sides of the oil can are depressed once and held depressed until the drop is released from the nozzle.

**3.32** A film of KS-19139, List 4 lubricant is the amount of lubricant deposited on the surface of a part after being brushed with the KS-14164 brush which has been dipped into the lubricant to

a depth of 3/8-inch and brushed lightly against the side of the container as the brush is removed.

### 3.33 Lubricate as follows:

**Caution:** Do not allow any KS-16326, List 1 oil or KS-19139, List 4 lubricant to get on the recording band, drive belt, pulley surfaces, or motor shaft.

- (a) Apply a thin film of KS-19139, List 4 lubricant to surfaces of all gear teeth, Fig. 6(A), threads of feed screw, Fig. 6(B), and half nut which is mounted on bracket assembly. Stir lubricant thoroughly before using.
- (b) Apply two drops of KS-16326, List 1 oil to the bearings at each end of the feed screw, Fig. 6(C). Apply where feed screw enters bearing.

**Caution:** Do not remove feed screw bearing plate or bail stop.

#### (c) Motors:

- (1) Sets equipped with KS-15914, List 1 motor require two drops of KS-16326, List 1 oil to each of the two motor shaft bearing oil holes and two drops to the oil hole of the rear bearing of motor. Keep oil off motor shaft, belt, and band.

- (2) Sets equipped with KS-15914, List 2 motor, no lubrication of motor required.

- (3) Sets equipped with B-650412 drive assembly containing a B-650418 motor requires two drops of KS-16326, List 1 oil to each of the two oil reservoirs [one at the shaft and one at the rear of the motor, Fig. 6(D)], as applicable. Earlier models of the motor require no lubrication.

(d) Record of Lubrication: The telephone company should maintain a record showing the dates lubricants were applied to the recording band (3.34), the gear teeth, feed screw, and half nut [3.33(a)], and the feed screw bearings and motor [3.33 (b) and (c)].



**CLEANING**

**Note:** Always clean recording band and head on same visit. The recording band shall be cleaned and lubricant every three months.

**3.34 To clean recording band:**

- (1) Moisten a clean KS-2423 twill jean or other approved lint-free cloth slightly with KS-16328, List 2 cleaner-lubricant.
- (2) Wipe recording band thoroughly.
- (3) Wipe dry with another clean, dry, lint-free cloth.
- (4) Repeat if necessary. The band should have a dry polished surface with no trace of dirt remaining.
- (5) After cleaning, lubricate the band, by applying a thin film of G.E. SF-1147 200 Cs silicone oil to the recording band using a KS-2423 cloth.

**3.35 To clean recording head pole piece.**

- (1) Pivot head away from recording band and lock against carriage with head locking spring.
- (2) Place a clean, dry KS-2423 cloth over band and adjacent parts to prevent damage by cleaner.

(3) Moisten another clean KS-2423 cloth with KS-16328, List 2 cleaner and rub surface of pole piece clean.

(4) Dry recording head surface and any surfaces contacted by the cleaner with a clean KS-2423 cloth.

**3.36** For more detailed information on the maintenance and lubrication of the KS-16765, List 3, refer to Sections 034-354-701 and 034-354-801.

**3.37 Ordering Information for Lubricants:**

KS-19139, List 4  
(Lubricant)

American Oil and  
Supply Company  
238 Wilson Avenue  
Newark, New Jersey  
07105

G. E. SF-1147  
(Silicone Oil)

Wilcox Electric  
Company  
14th and Chestnut  
Street  
Kansas City, Missouri  
64127  
Part # 264847-1

KS-16328, List 2  
(Cleaner-Lubricant)

WECO Supply Center  
650 Liberty Avenue  
Union, New Jersey  
07083

KS-16326, List 1  
(Oil)