

COMMON AUDIBLE SIGNALING KEY TELEPHONE SYSTEMS

GENERAL

- 1.01** This section provides a general description of common audible signaling arrangements, especially those using diode matrix or signal control relays. It also describes the need and use of the 141A protector and 840A diode assembly.
- 1.02** This section is reissued to provide information about the 840A diode assembly and to add a note limiting the use of the 141A protector.
- 1.03** Common audible signaling provides for:
- Signaling one station from more than one CO, Centrex, PBX, or intercom line
 - Signaling more than one station from one CO, Centrex, PBX, or intercom line
 - Signaling combinations of the previous arrangements (with these combinations, a diode matrix or signal control relay is required).
- 1.04** Common audible signaling arrangements, which utilize a local frequency generator (110 volts, 30 Hz) for operating ringers, can be subjected to voltage spikes of sufficient amplitude to damage key telephone units (KTUs) and/or blow fuses. Depending on the phase of the current through the ringer when the current is interrupted, voltage spikes of either polarity can appear on the RC lead.
- 1.05** To protect against these ringer transients, a 141A protector is connected between the B1 and R1 terminals in the station cable to each ringer.
- Note:** ♦The 141A protector is not required if a 400G or 400H KTU is used in the line circuit.♦

2. COMMON AUDIBLE SIGNALING CIRCUITS-OPERATION

- 2.01** A simplified schematic of one audible signal operated from two lines is shown in Fig. 1. A call on line 1 operates relay R in line circuit 1 causing contact R to make. The ac signal is applied through diode CR1. Diode CR1 allows the positive components of the ac signal to operate the common audible signal. Diode CR2 isolates line circuit 2 from this signal. A call on line 2 will result in relay R in line circuit 2 operating and applying the ac signal via CR2.
- 2.02** If the station audible signal (Fig. 1) will be rung only from lines 1 and 2, and if these lines will not ring any other station, the diodes and diode matrix are not required.
- 2.03** *Common Ringing Lead:* A simplified schematic of one line operating two-station audible signals is shown in Fig. 2. A call on line 1 operates relay R, causing contact R to make. The ac signal is applied through diodes CR1 and CR2. The positive components of the ac signal operates both station audible signals.
- 2.04** If no other line will ring station A or B (Fig. 2), the diodes and matrix are not required. Ringers in the stations can be rung directly from tip and ring of the line.
- 2.05** A simplified schematic of a two line, three-station common audible signaling arrangement is shown in Fig. 3. A call on line 1 results in a signal at stations A and B, but not C since diode CR3 blocks the path. A call on line 2 results in a signal at stations B and C, but not A due to diode CR2. Station B is common to lines 1 and 2. Stations A and B are common to line 1. Stations B and C are common to line 2.

NOTICE

Not for use or disclosure outside the
Bell System except under written agreement

3. COMMON AUDIBLE SIGNALING APPLICATIONS

3.01 An example of a diode matrix installation is shown in Fig. 4. To the left is a schematic representation of the 1A1 matrix block at the right. Diodes (446 type or equivalent) are connected so their arrows point towards the station audible signals, permitting five signaling leads to control six audible signals. The block could also be wired to permit six signaling leads to control five audible signals by connecting the signaling leads at the left side (A-F) and the audible signals at the top (1-5). For this configuration all diodes must be connected so their arrows point toward the audible signals.



All line circuits connected to a diode matrix must be supplied from the same ringing supply and interrupter contact.

3.02 A strap is used to connect a signaling lead to an audible signal if neither is common to any other signaling lead or audible signal. An example of this is the strap between signaling lead 5(CA) and audible signal F (Fig. 4).

3.03 Diode control limits the type of audible signal to either all ringers or all ac buzzers (do not mix). **To avoid diode failure, never use dc buzzers.** When ringers are used, the ringing capacitor of each station should be disconnected and bypassed and the red ringer lead should be connected to the diode matrix.



A positive component results after an ac signal has passed through a diode in the direction of the "arrow." This positive component cannot pass through a diode against the arrow. On this principle a diode matrix separates audible signals and signaling leads. ALL DIODES AND RINGERS (IF USED) MUST BE POLARIZED IN THE SAME DIRECTION.

3.04 The matrix in Fig. 4 is arranged so that:

CALL ON LINE	STATION(S) SIGNALLED
1*	B
2	A, B, and C
3	A, C, and D
4	A, C, and E
5*	F

* Signaling leads 1 and 5, corresponding to lines 1 and 5, are not common signaling leads since they each control only one audible signal.

3.05 For a detailed description of the 1A1 matrix blocks, see Section 461-620-100.

3.06 Section 518-215-403 provides functional schematics of the 402A and 404A (diode matrix) KTUs.

3.07 Common audible signaling can also be accomplished with the use of signal control relays in place of a diode matrix. The same principles apply. Instead of diodes, relay contacts connect the ringing leads to the proper ringers. Section 518-310-401 provides various connections using the 227B KTU as a common audible signal control.

3.08 ♦To provide common audible signaling on large key systems, a matrix arrangement can be provided by using 66B- or 66M-type connecting blocks and 840A diodes. The 840A diode is an assembly consisting of a 533F diode connected to two spring contacts encapsulated in a clear plastic housing. The 840A diode is inserted on adjacent terminals of the 66-type connecting blocks.♦

3.09 ♦A typical common audible signaling arrangement using a 66B-type connecting block, and 840A diode for signaling one common audible signal from three CO/PBX lines, is shown in Fig. 6. Refer to Fig. 7 for the polarity designation of the 840A diode.♦

4. 141A PROTECTOR

4.01 The 141A protector (Fig. 5) consists of 68,000 ohm, 1/2-watt resistor in a blue molded assembly. The dimensions of the protector are 6/10-inch by 1/2-inch by 3/10-inch, and it is designed to be installed on 66-type connecting blocks having quick-connect terminals.

4.02 The 141A protector is inserted between the B1 and R1 terminals in the station cut-down field (Blue Field) without affecting the cut-down multiple. See Fig. 1, 2, and 3.

03 For new key telephone system (KTS) installations, every station served by a local

frequency generator should be protected by 141A protectors. At existing installations, protectors should be installed for each station (served by a local frequency generator) during routine servicing of the installation.

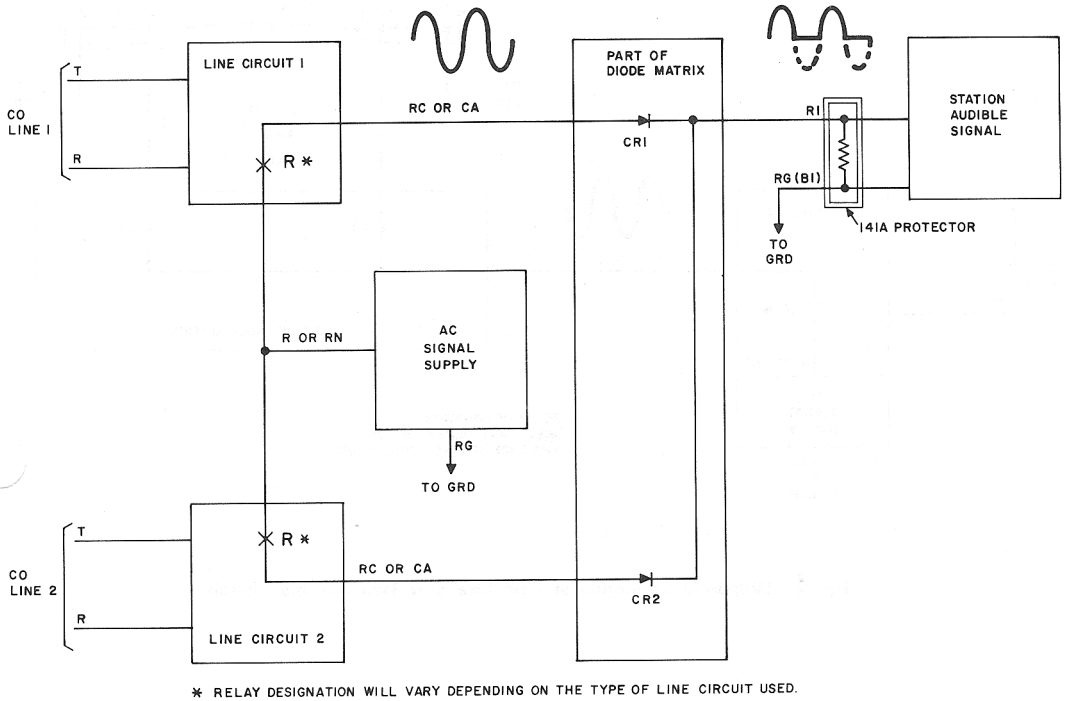

Fig. 1—Simplified Schematic of Two Lines and One Audible Signal

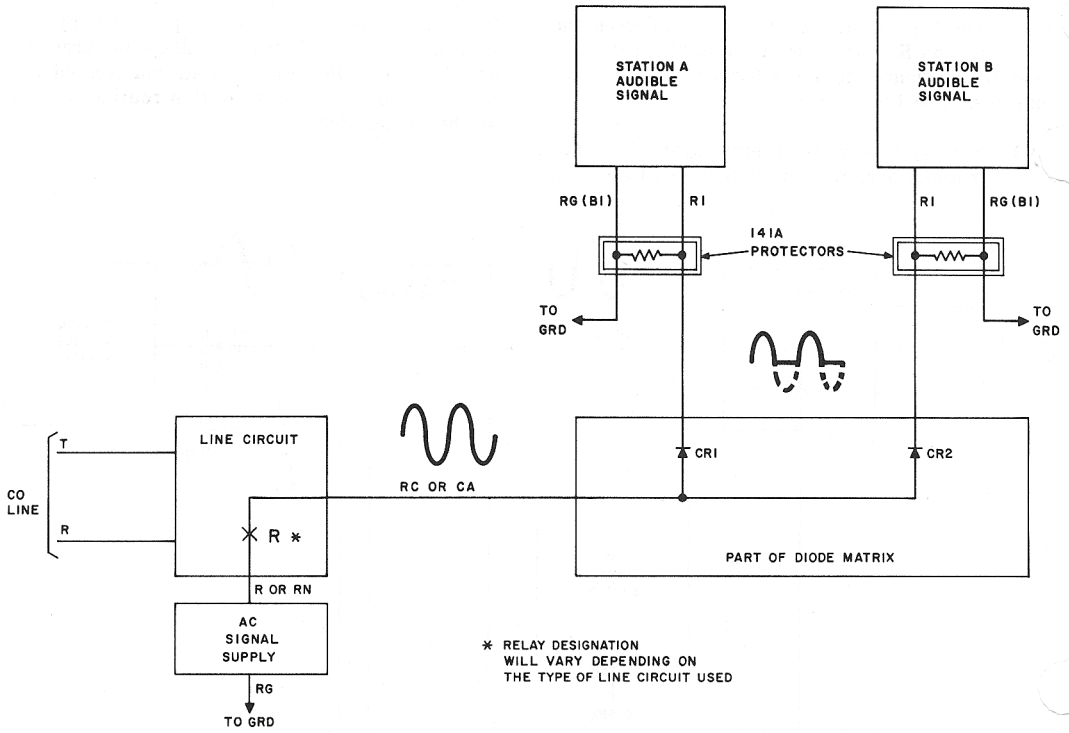

Fig. 2—Simplified Schematic of One Line and Two Audible Signals

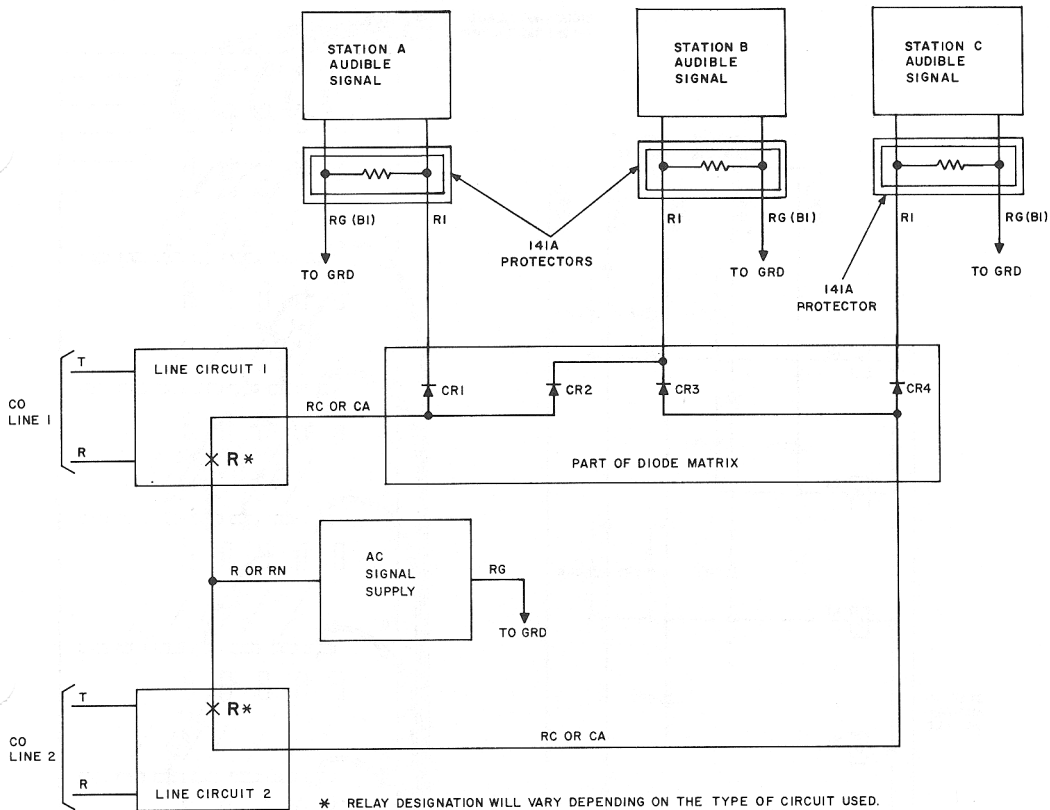

Fig. 3—Simplified Schematic of Two Lines and Three Audible Signals

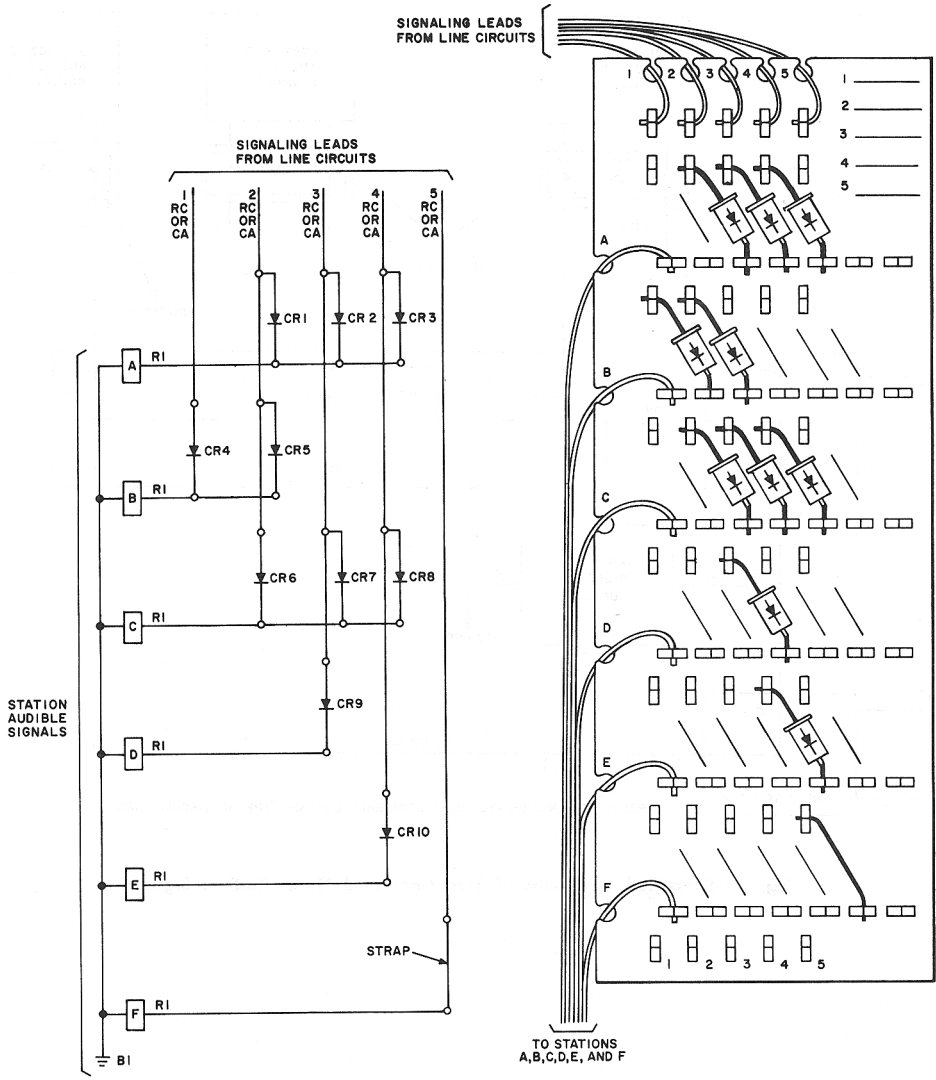

Fig. 4—1A1 Matrix Block Application

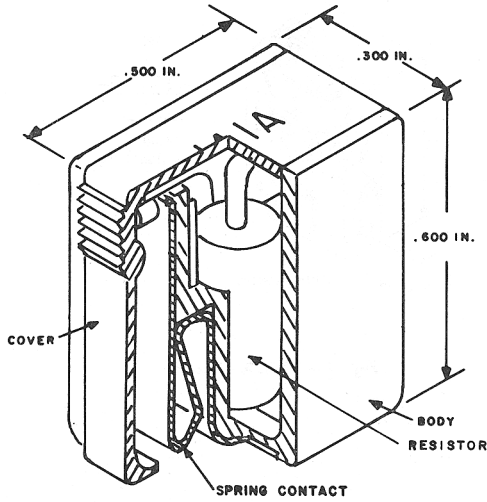

Fig. 5—141A Protector

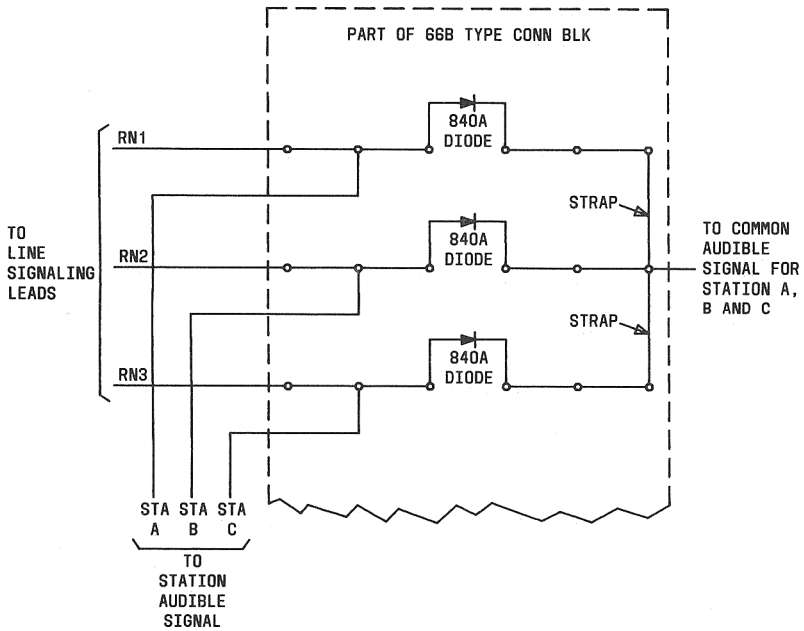

Fig. 6—Typical Common Audible Signaling Arrangement on 66-Type Connecting Block With 840A Diode

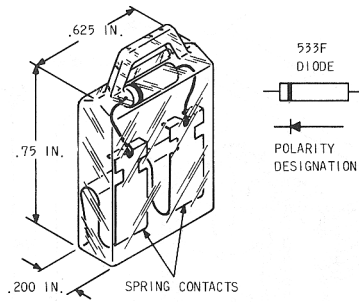

Fig. 7—840A Diode