

## PANELS

### 583- AND 584-TYPE

### CONNECTIONS AND MAINTENANCE

#### 1. GENERAL

**1.01** Information in this section was formerly contained in Section 518-270-401 which is hereby canceled. Information has been added on the 584C panel, which replaces the 584B panel used in large centralized installations of 1A2 Key Telephone System arrangements.

**1.02** This issue of the section is based on the following drawings:

SD-69502-01, Issue 2D

SD-69552-01, Issue 4D

SD-69591-01, Issue 1

If this section is to be used with equipment or apparatus reflecting later issues of the drawings, reference should be made to the SDs and CDs to determine the extent of the changes and the manner in which the section may be affected.

**1.03** Station, power, and interpanel connections to 583A and 594A panels are made to wire-wrap terminals. The KS-16363, List 1 hand grip wrapping tool should be used to wrap stripped wires. A KS-16492, List 2 unwrapping tool should be used to remove a wire-wrapped termination.



*Sections 069-132-811, 069-120-811, 075-120-701, and 074-820-101 provide reference guides to tool identification, parts, operational requirements, and ordering information, plus approved preparation procedures for connecting wires to terminals.*

**1.04** Power and interpanel connections to 584B and 584C panels are made to screw terminals. Station connections are made by using connector cables.

#### 2. CONNECTIONS

**2.01** Fig. 1 shows various typical arrangements using 583- and 584-type panels. Refer to Fig. 1 for power connection figure reference and interpanel wiring used with the selected arrangement.

**2.02** Terminate station, CO, or PBX line connections directly to panels or to 66-type connecting blocks at the master distribution point (see Table A).

#### 2.03 *Connection Index*

Fig. 1—Block Diagram Showing Arrangements of 583A (MD), 584A (MD), 584B, and 584C Panels

Fig. 2—584A (MD) Panel Equipped with Interrupter (Panel can be used alone and also to control one other panel)

Fig. 3—583A (MD) or 584A (MD) Not Equipped With Interrupter or 412A KTU

Fig. 4—584B Panel Equipped With Interrupter (Panel not used to control other panels)

Fig. 5—584B Panel Equipped With Interrupter (Panel used to control one other panel)

Fig. 6—584B Panel Not Equipped With Interrupter or 412A KTU

Fig. 7—584C Panel Not Equipped With Interrupter or 412A KTU

Fig. 8—584C Panel Equipped With Interrupter (Panel not used to control other panels)

Fig. 9—584C Panel Equipped With Interrupter (Panel used to control one other panel)

Fig. 10—584B Panel Equipped With Interrupter (Master panel used to control up to

200 other panels each equipped with 412A KTU)

Fig. 11—584B Panel Equipped With 412A KTU (Panel used to control one other panel)

Fig. 12—584B Panel Equipped With 412A KTU (Panel not used to control other panels)

Fig. 13—584A (MD) Panel Equipped With 412A KTU (Panel used alone and also to control one other panel)

Fig. 14—584C Panel Equipped With 412A KTU (Panel not used to control other panels)

Fig. 15—584C Panel Equipped With Interrupter (Master panel used to control up to 200 other panels each equipped with 412A KTU)

Fig. 16—584C Panel Equipped With 412A KTU (Panel used to control one other panel)

Fig. 17—Modification of 584A (MD) Panel to Accept 412A KTU

Fig. 18—Manual Intercommunication Connections for 583A (MD) and 584A (MD) Panels

Fig. 19—Typical Functional Layout of 584C and B Panels Showing Line Circuit 1 Only

Table A—Connections to Distribution Points and/or to Panels

**3. MAINTENANCE**

**3.01** Maintenance on panels should be limited to tracing of wiring troubles, fuse replacement, and replacement of improperly operating KTUs.

**3.02** When trouble is encountered, proceed as follows:

- (a) Visit station reporting trouble
- (b) Determine if trouble is located at the individual station or common to the system.
- (c) If common to the system:
  - (1) Check power supply and fuses
  - (2) Determine which KTU is not operating properly
  - (3) Replace KTU with one known to be in operating condition to determine whether trouble is located in the KTU or in external circuitry.

**Note:** Ensure that the applicable options are correctly strapped on the replaced KTU.

- (4) If replacement of the KTU does not correct the trouble, it is external to the KTU and the complete wiring should be verified.

6  
5  
3

2 507

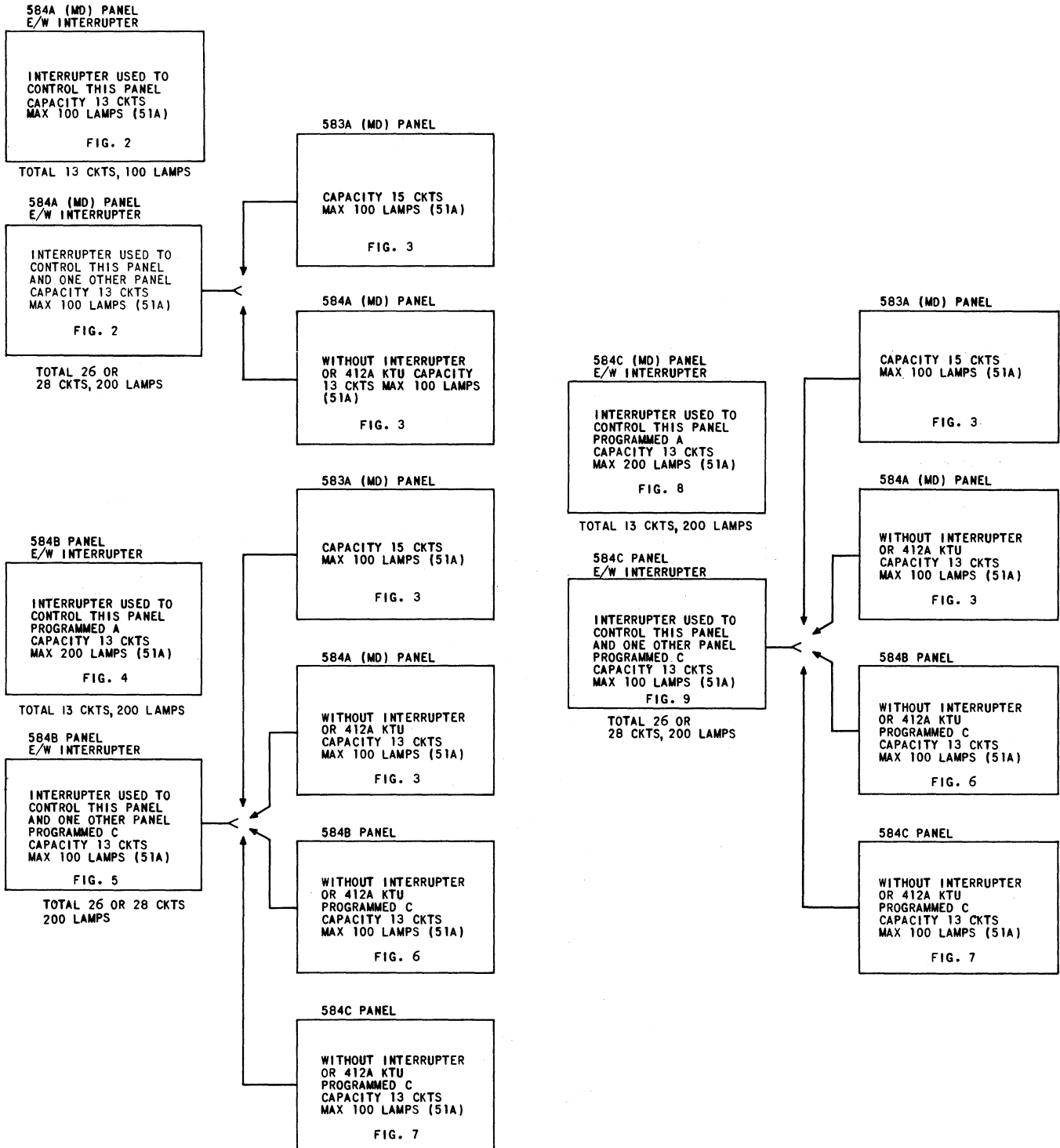

Fig. 1—Block Diagram Showing Arrangement of 583A (MD), 584A (MD), 584B, and 584C Panels (Sheet 1 of 3)

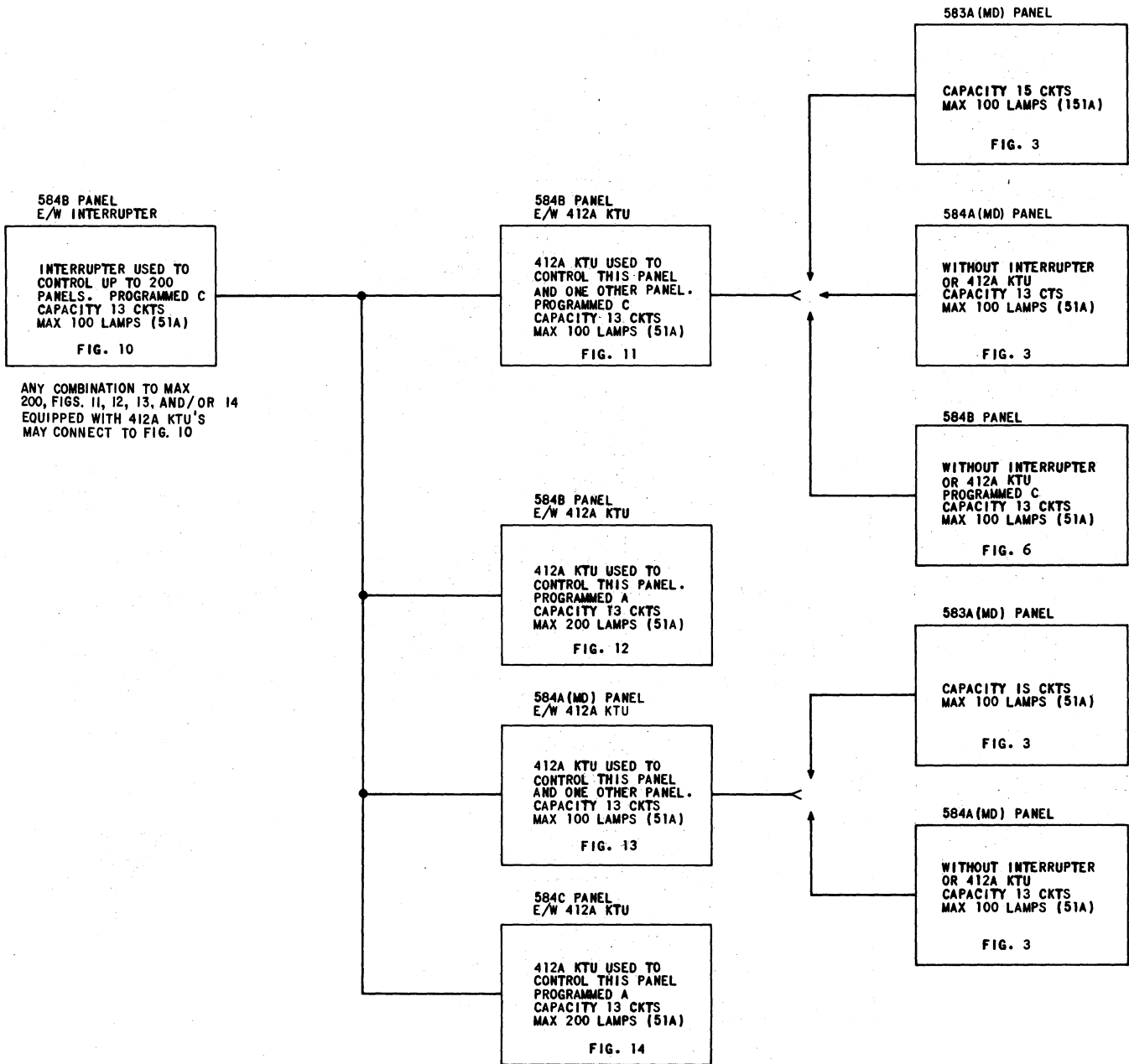

Fig. 1—Block Diagram Showing Arrangement of 583A (MD), 584A (MD), 584B, and 584C Panels (Sheet 2 of 3)

508  
2

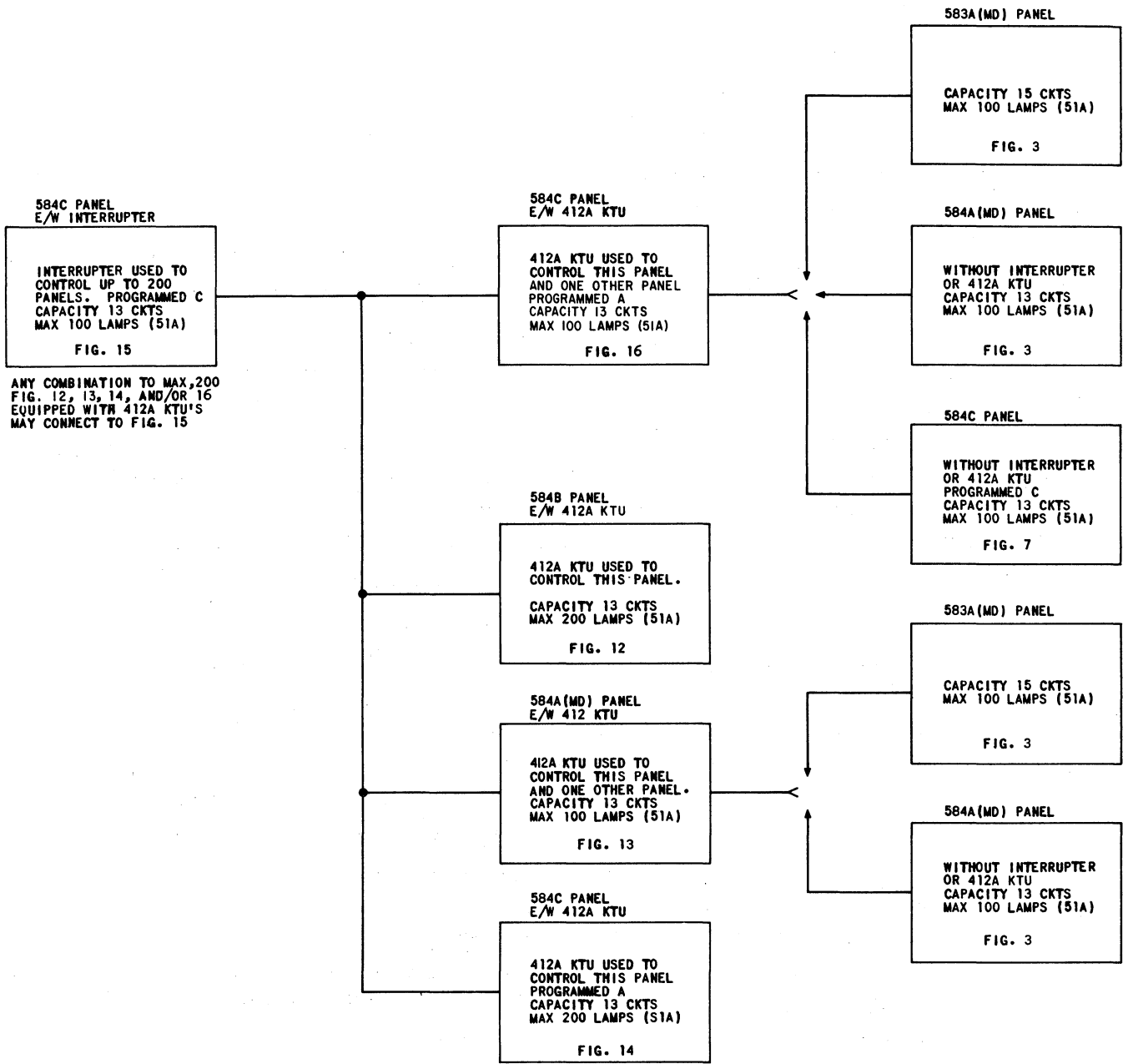

Fig. 1—Block Diagram Showing Arrangement of 583A (MD), 584A (MD), 584B, and 584C Panels (Sheet 3 of 3)

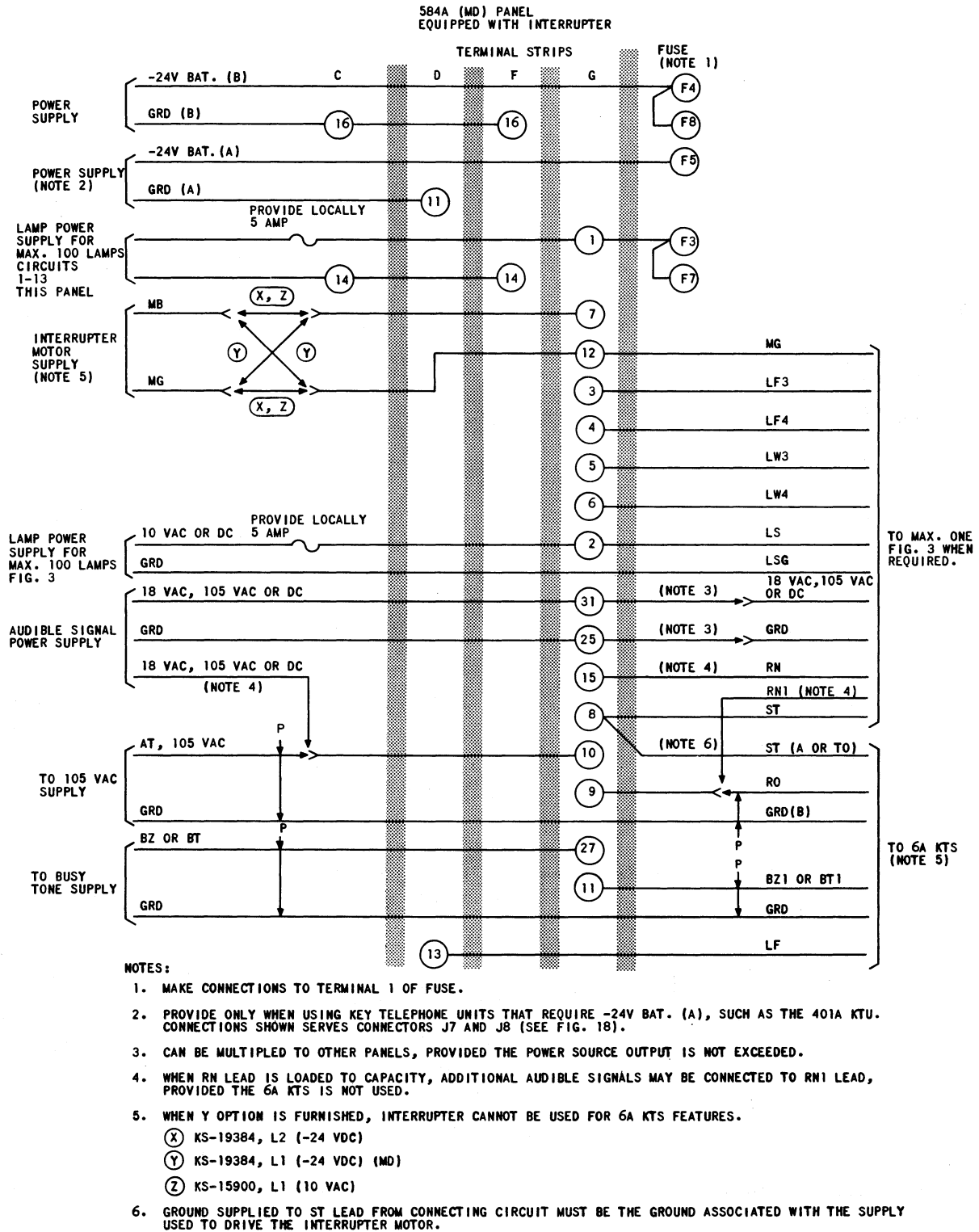
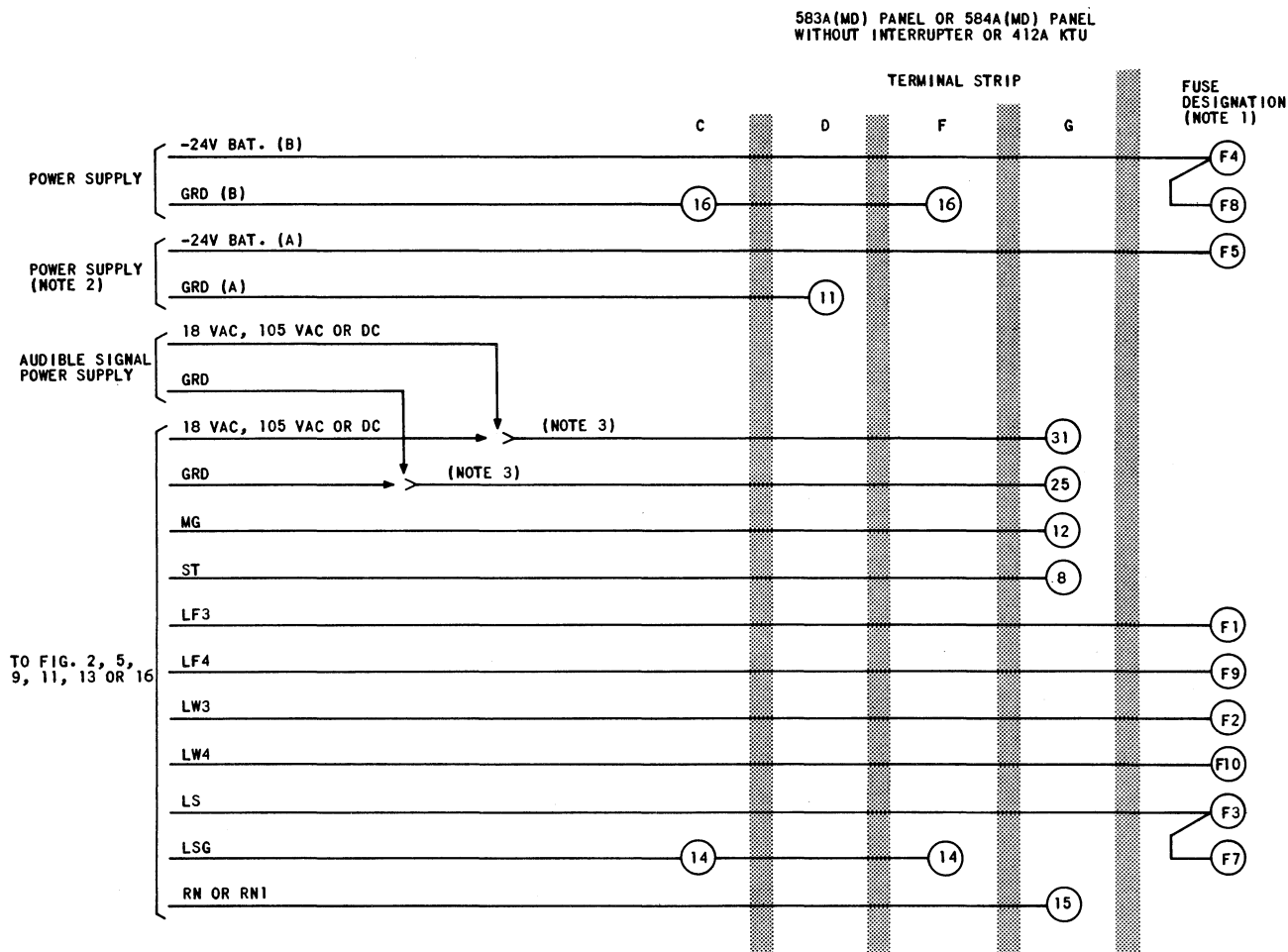

Fig. 2—584A (MD) Panel Equipped With Interrupter (Panel can be used alone and also to control one other panel)



NOTES:

1. MAKE CONNECTIONS TO TERMINAL 1 OF FUSE.
2. PROVIDE ONLY WHEN USING KEY TELEPHONE UNITS THAT REQUIRE -24V BAT. (A), SUCH AS THE 401A KTU. CONNECTION AS SHOWN SERVES CONNECTORS J7 AND J8 (SEE FIG. 18).
3. IF LEADS FROM PRECEDING PANEL ARE LOADED TO CAPACITY, PROVIDE SEPARATE AUDIBLE SIGNAL POWER TO THIS PANEL.

Fig. 3—583A (MD) or 584A (MD) Panel Not Equipped With Interrupter or 412A KTU

2 5 1 1

SECTION 518-215-410

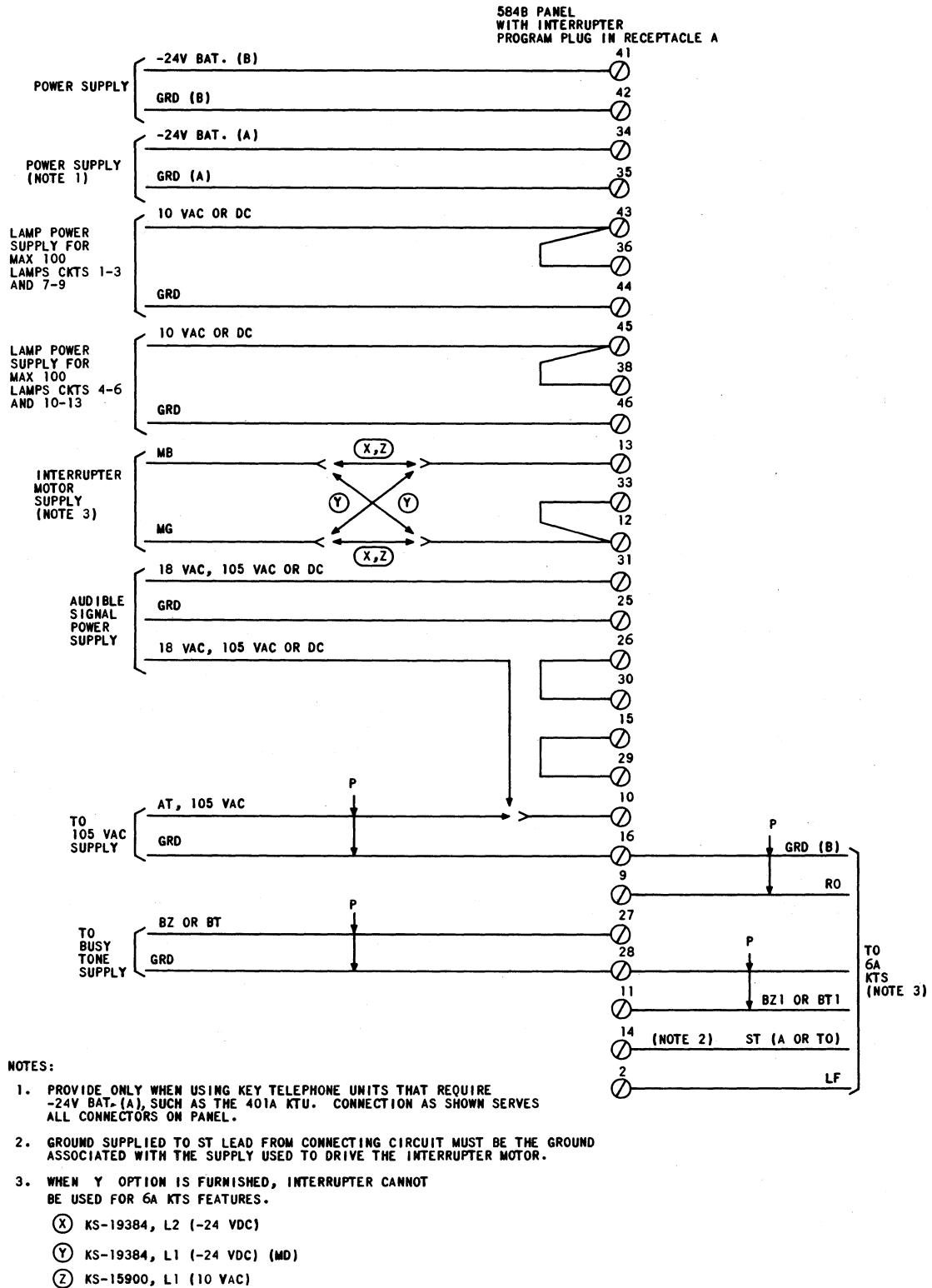

Fig. 4—584B Panel Equipped With Interrupter (Panel not used to control other panels)



584B PANEL  
WITH INTERRUPTER  
PROGRAM PLUG IN RECEPTACLE C

NOTES:

1. PROVIDE ONLY WHEN USING KEY TELEPHONE UNITS THAT REQUIRE -24V BAT.(A), SUCH AS THE 401A KTU. CONNECTIONS AS SHOWN ARE FOR ALL CONNECTORS ON PANEL.
  2. WHEN RN LEAD IS LOADED TO CAPACITY, ADDITIONAL AUDIBLE SIGNALS MAY BE CONNECTED TO RN1 LEAD, PROVIDED THE 6A KTS IS NOT USED.
  3. CAN BE MULTIPLIED TO OTHER PANELS, PROVIDED THE POWER SOURCE OUTPUT IS NOT EXCEEDED.
  4. WHEN Y OPTION IS FURNISHED, INTERRUPTER CANNOT BE USED FOR 6A KTS FEATURES.
- (X) KS-19384, L2 (-24 VDC)  
 (Y) KS-19384, L1 (-24 VDC) (MD)  
 (Z) KS-15900, L1 (10 VAC)
5. GROUND SUPPLIED TO ST LEAD FROM CONNECTING CIRCUIT MUST BE THE GROUND ASSOCIATED WITH THE SUPPLY USED TO DRIVE THE INTERRUPTER MOTOR.

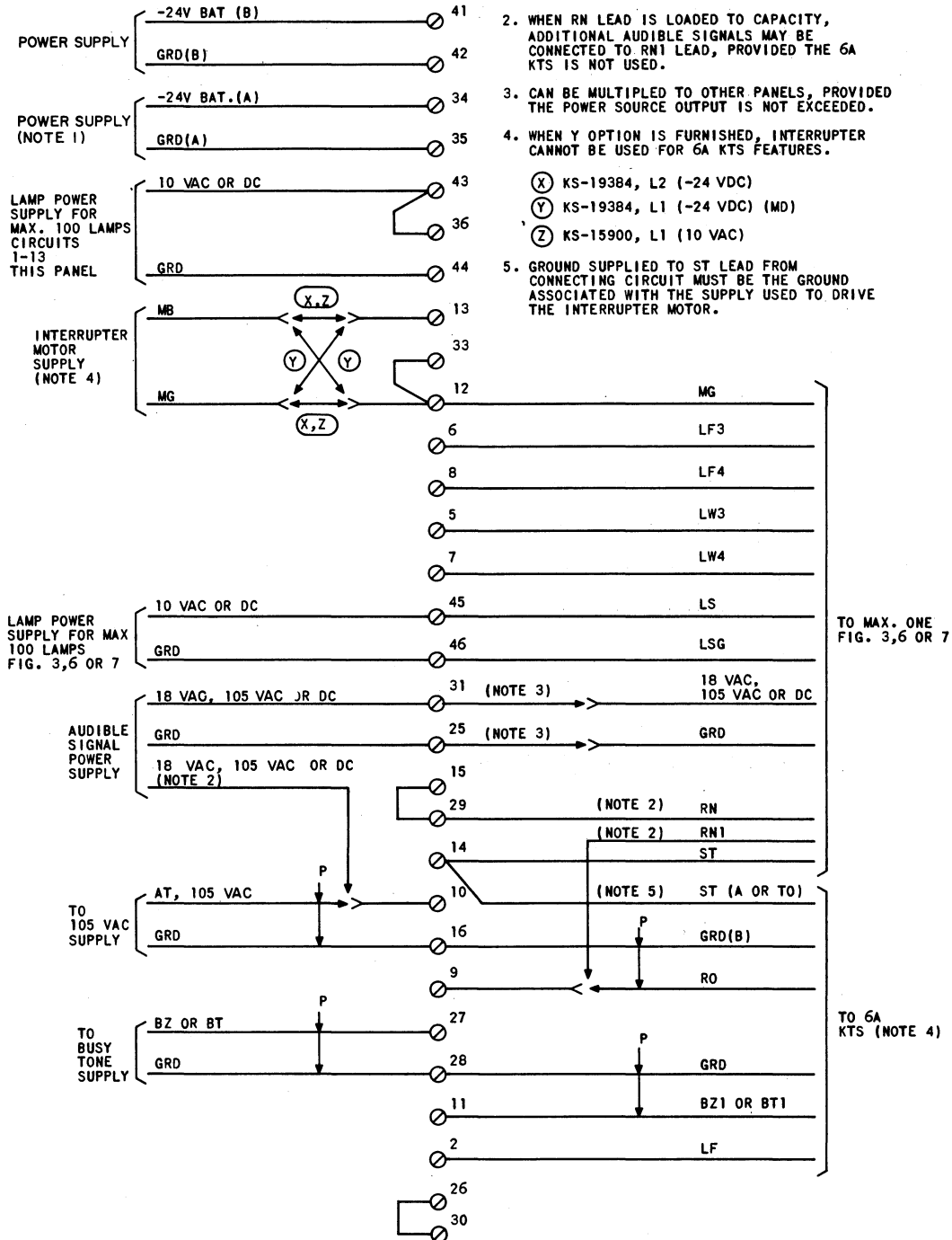
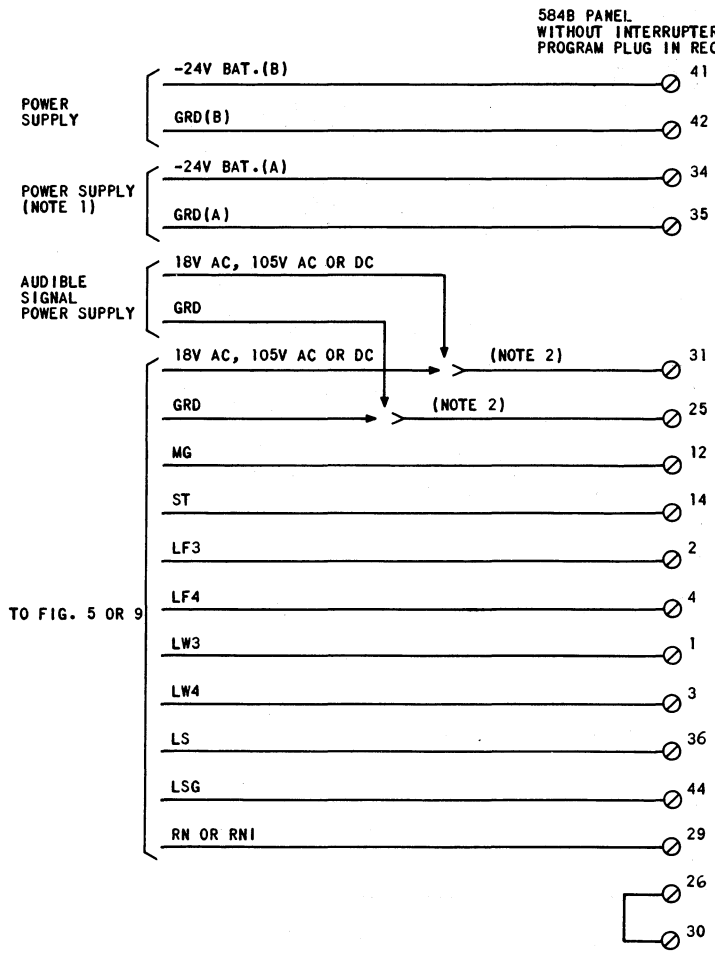

Fig. 5—584B Panel Equipped With Interrupter (Panel used to control one other panel)

SECTION 518-215-410



- NOTES:
1. PROVIDE ONLY WHEN USING KEY TELEPHONE UNITS THAT REQUIRE -24V BAT.(A), SUCH AS THE 401A KTU. CONNECTION AS SHOWN SERVES ALL CONNECTORS ON PANEL.
  2. IF LEADS FROM PRECEDING PANEL ARE LOADED TO CAPACITY, PROVIDE SEPARATE AUDIBLE SIGNAL POWER TO THIS PANEL.

Fig. 6—584B Panel Not Equipped With Interrupter or 412A KTU

514

584C PANEL  
WITHOUT INTERRUPTER  
OR 412A KTU  
USING PROGRAM C PLUG

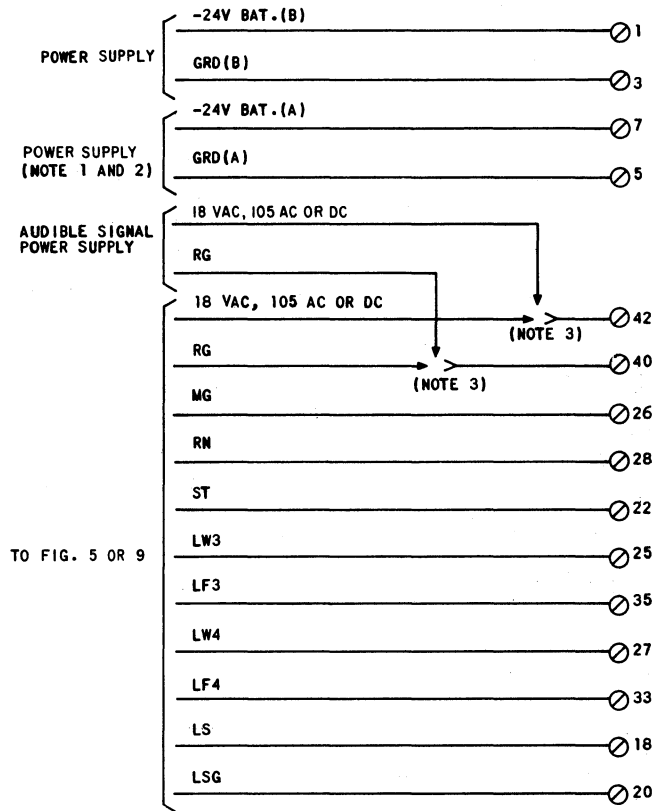

NOTES:

1. PROVIDE ONLY WHEN USING KEY TELEPHONE UNITS THAT REQUIRE -24V BAT.(A), SUCH AS THE 401A KTU.
2. WHEN MORE THAN ONE SUPPLY IS USED TO PROVIDE -24 VDC AND 10 VAC POWER, POWER SUPPLY GROUND TERMINALS ARE BOUNDED TOGETHER.
3. IF LEADS FROM PRECEDING PANEL ARE LOADED TO CAPACITY, PROVIDE SEPARATE AUDIBLE SIGNAL POWER TO THIS PANEL.

Fig. 7—584C Panel Not Equipped With Interrupter or 412A KTU

2 5 1 5

SECTION 518-215-410

584C PANEL  
EQUIPPED WITH INTERRUPTER  
USING PROGRAM A PLUG

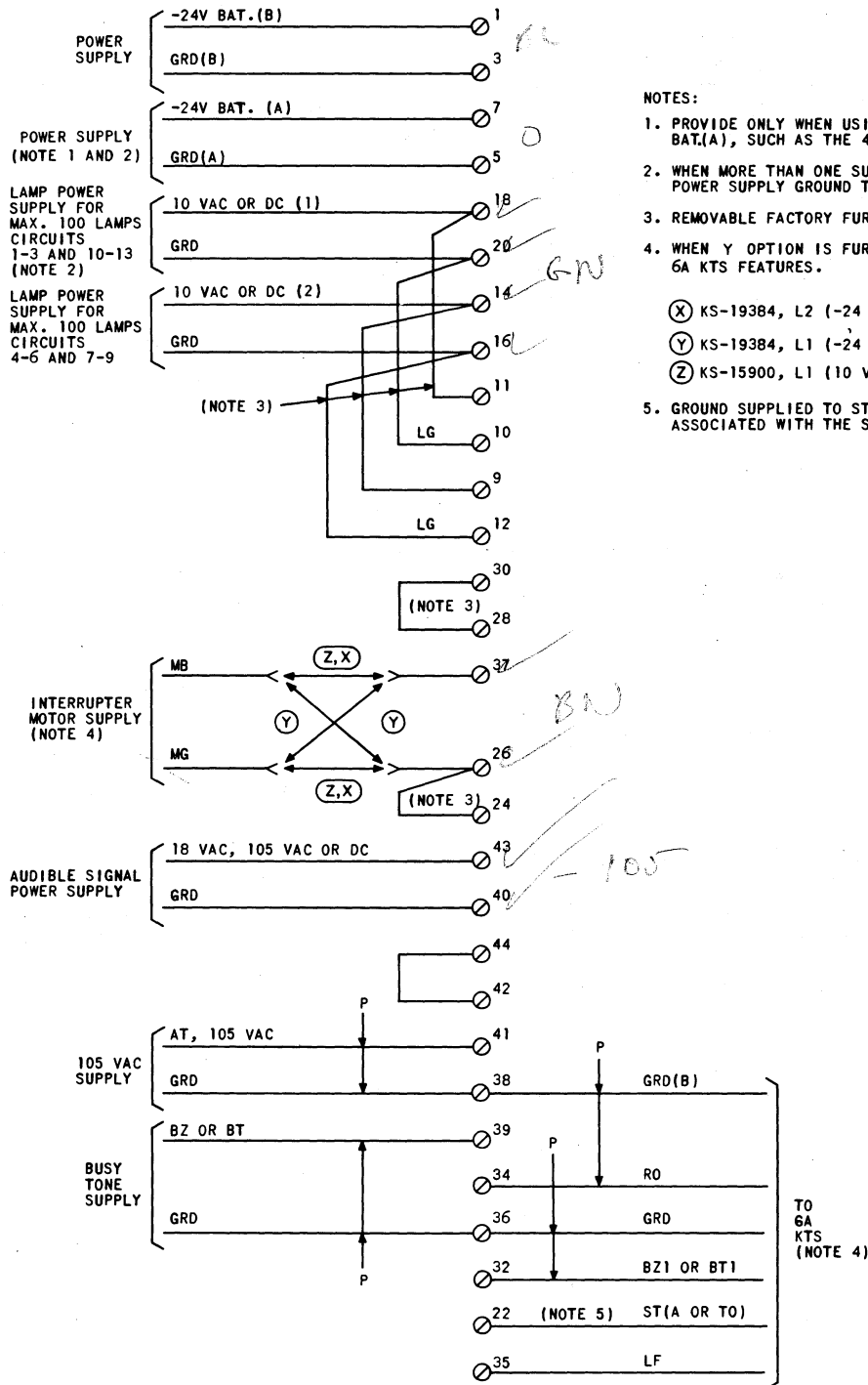

NOTES:

1. PROVIDE ONLY WHEN USING KEY TELEPHONE UNITS THAT REQUIRE -24V BAT.(A), SUCH AS THE 401A KTV.
2. WHEN MORE THAN ONE SUPPLY IS USED TO PROVIDE -24 VDC AND 10 VAC POWER, POWER SUPPLY GROUND TERMINALS ARE BONDED TOGETHER.
3. REMOVABLE FACTORY FURNISHED FIELD STRAP.
4. WHEN Y OPTION IS FURNISHED, INTERRUPTER CAN NOT BE USED FOR 6A KTS FEATURES.
  - (X) KS-19384, L2 (-24 VDC)
  - (Y) KS-19384, L1 (-24 VDC)(MD)
  - (Z) KS-15900, L1 (10 VAC)
5. GROUND SUPPLIED TO ST LEAD FROM CONNECTING CIRCUIT MUST BE THE GROUND ASSOCIATED WITH THE SUPPLY USED TO DRIVE THE INTERRUPTER MOTOR.

Handwritten notes on the right side of the page:

FEU - e  
10V - 100  
100 - 100  
"B" - BN  
"A" - SC

Fig. 8—584C Panel Equipped With Interrupter (Panel not used to control other panels)



SECTION 518-215-410

584B PANEL  
EQUIPPED WITH INTERRUPTER  
PROGRAM PLUG IN RECEPTACLE C

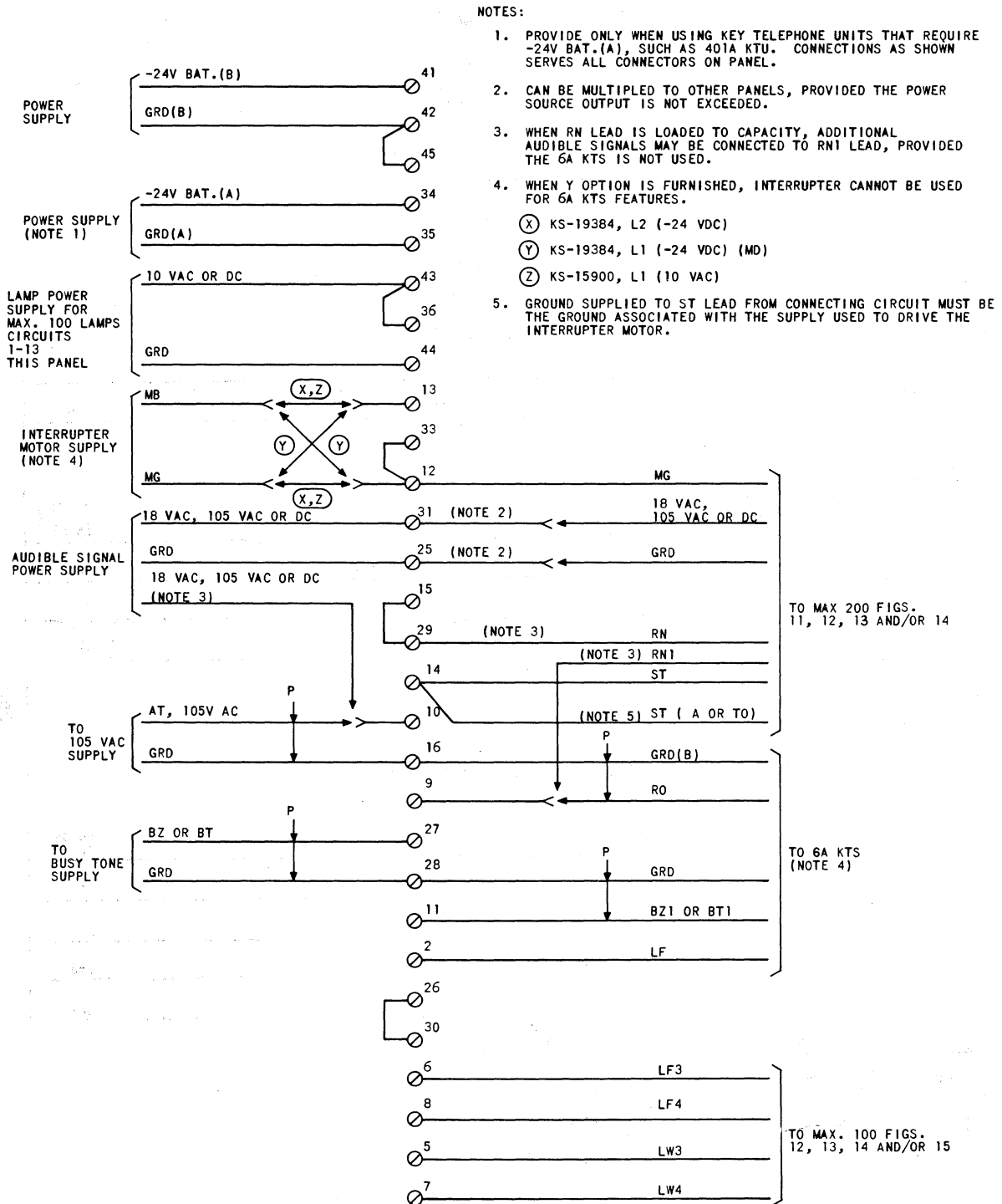

Fig. 10—584B Panel Equipped With Interrupter (Master panel used to control up to 200 other panels each equipped with 412A KTU)

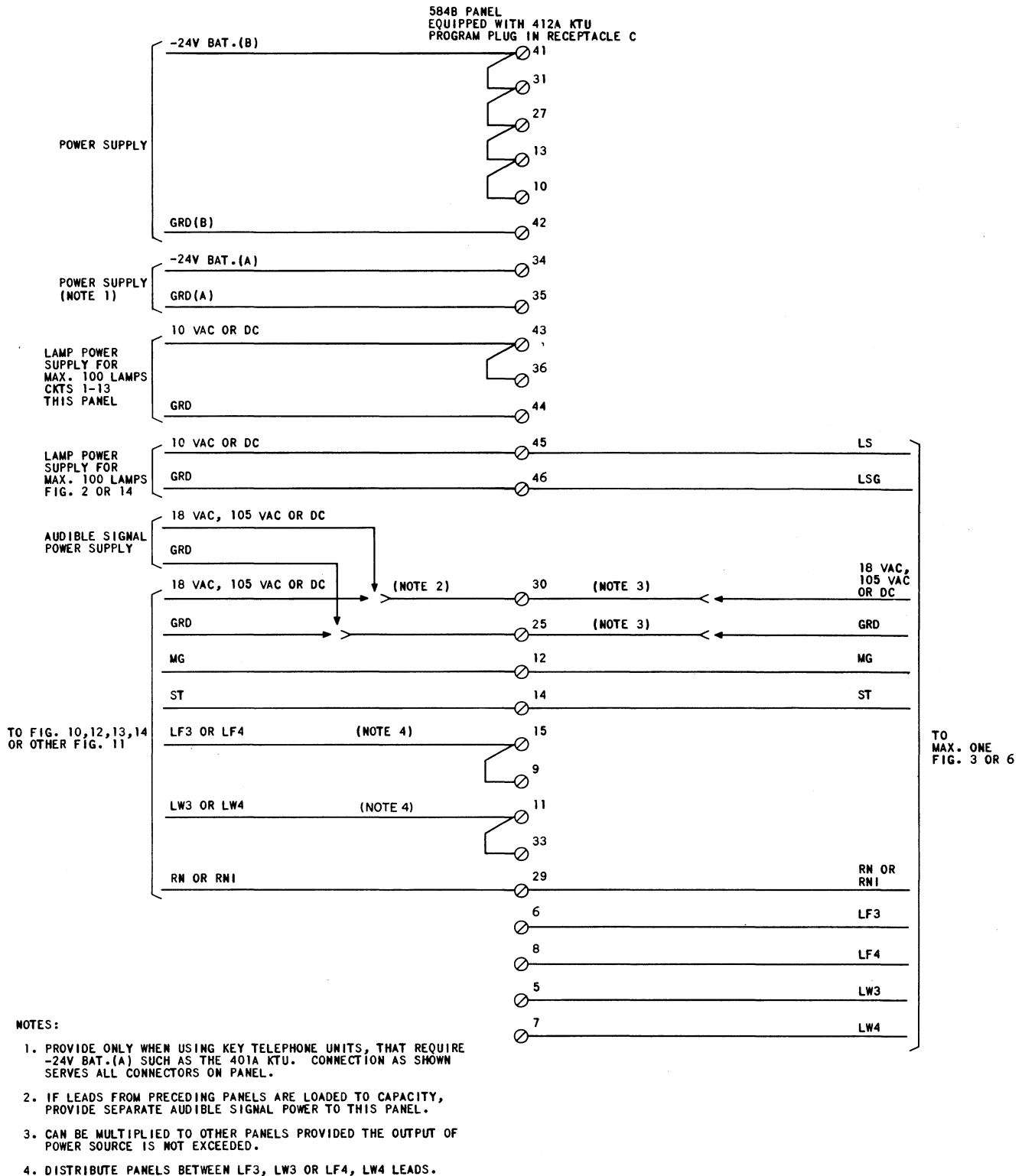

Fig. 11—584B Panel Equipped With 412A KTU (Panel used to control one other panel)

SECTION 518-215-410

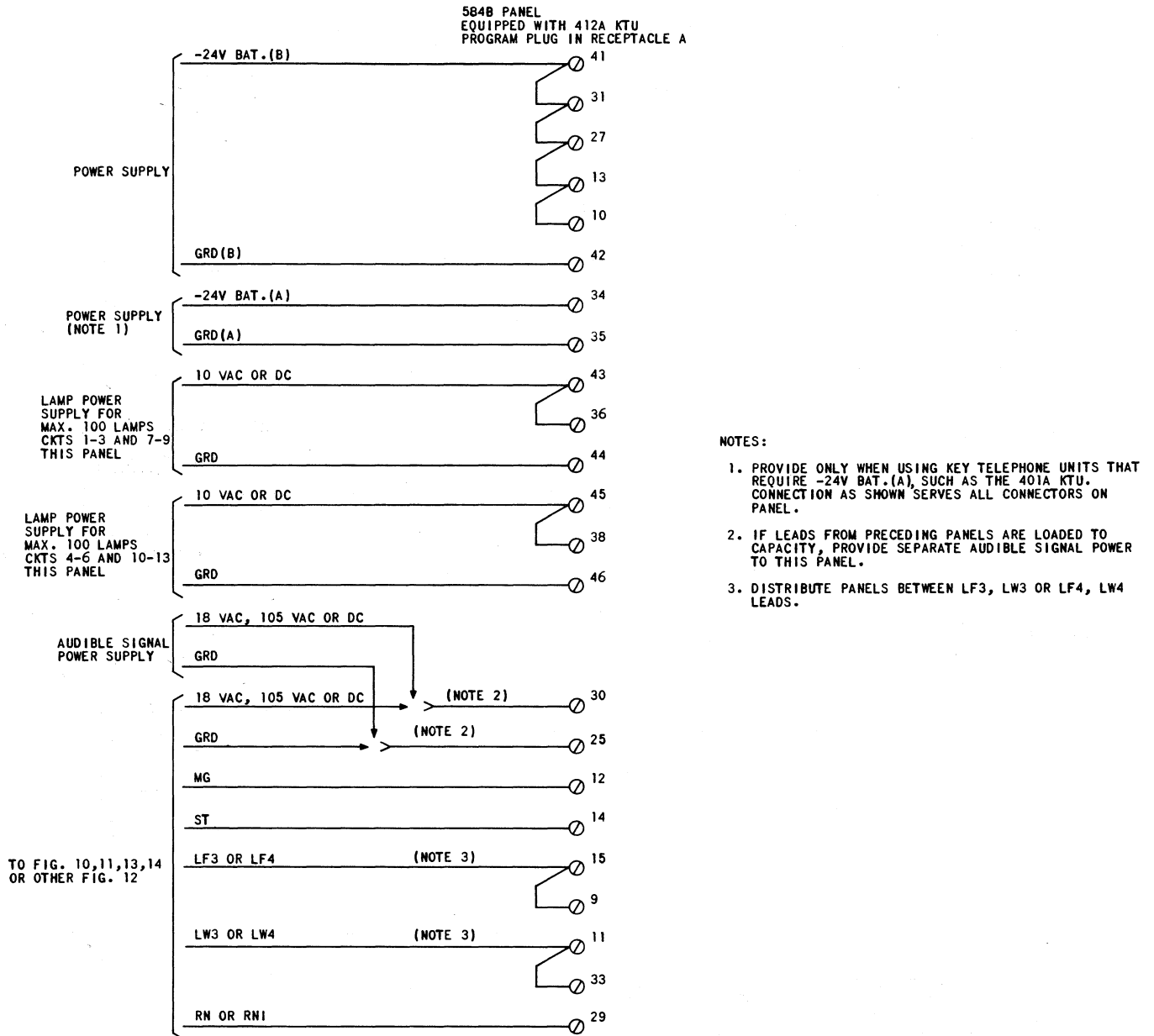
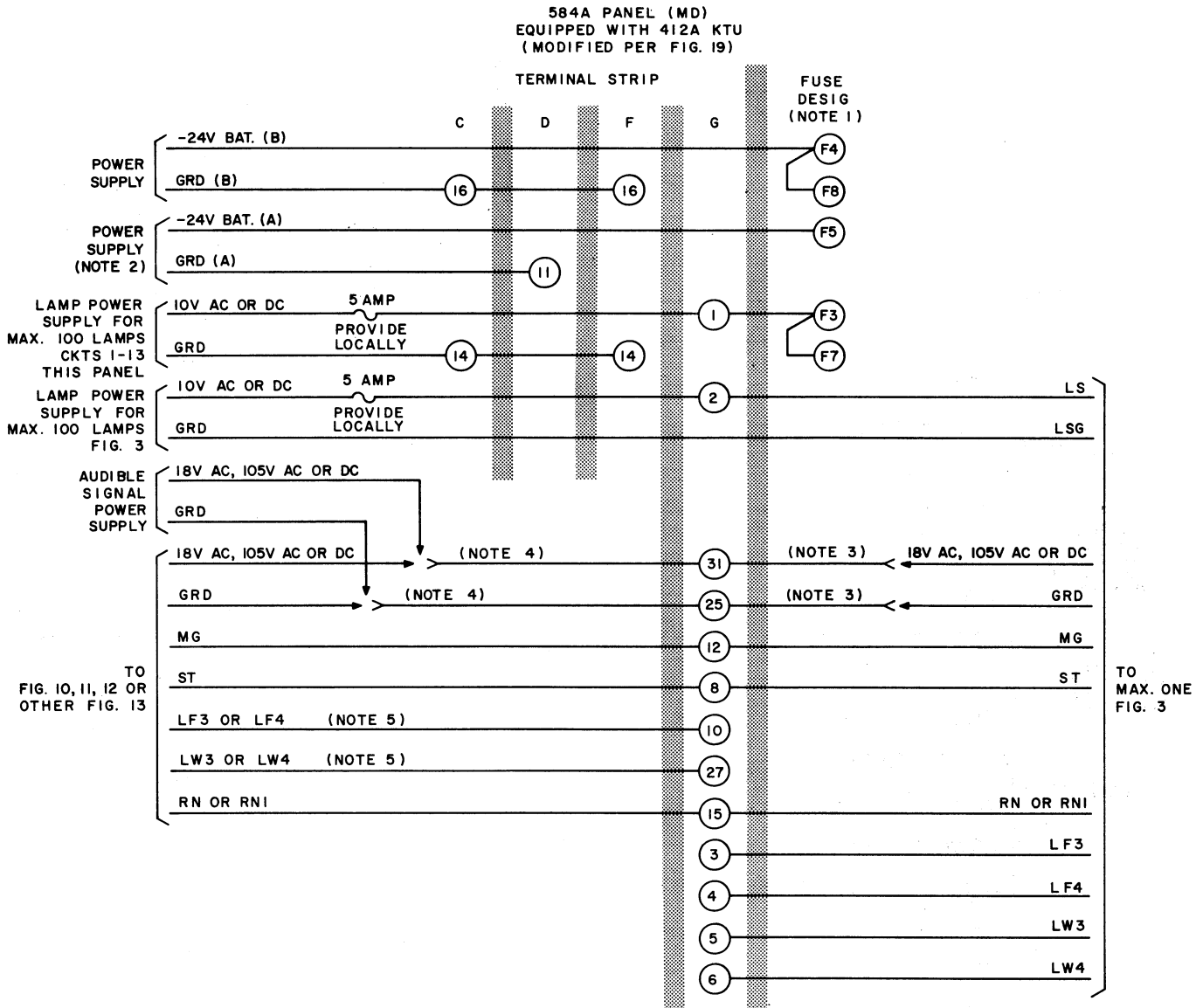

Fig. 12—584B Panel Equipped With 412A KTU (Panel not used to control other panels)





**NOTES:**

1. MAKE CONNECTIONS TO TERMINAL 1 OF FUSE.
2. PROVIDE ONLY WHEN USING KEY TELEPHONE UNITS THAT REQUIRE -24V BAT (A), SUCH AS THE 401A KTU. CONNECTION AS SHOWN SERVES CONNECTORS J7 AND J8 (SEE FIG. 18).
3. CAN BE MULTIPLIED TO OTHER PANELS PROVIDED THE OUTPUT OF POWER SOURCE IS NOT EXCEEDED.
4. IF LEADS FROM PRECEEDING PANELS ARE LOADED TO CAPACITY, PROVIDE SEPARATE AUDIBLE SIGNAL POWER TO THIS PANEL.
5. DISTRIBUTE PANELS BETWEEN LF3, LW3 OR LF4, LW4 LEADS.

**Fig. 13—584A (MD) Panel Equipped With 412A KTU (Panel used alone and also to control one other panel)**

SECTION 518-215-410

584C PANEL  
EQUIPPED WITH 412A KTU  
USING PROGRAM A PLUG

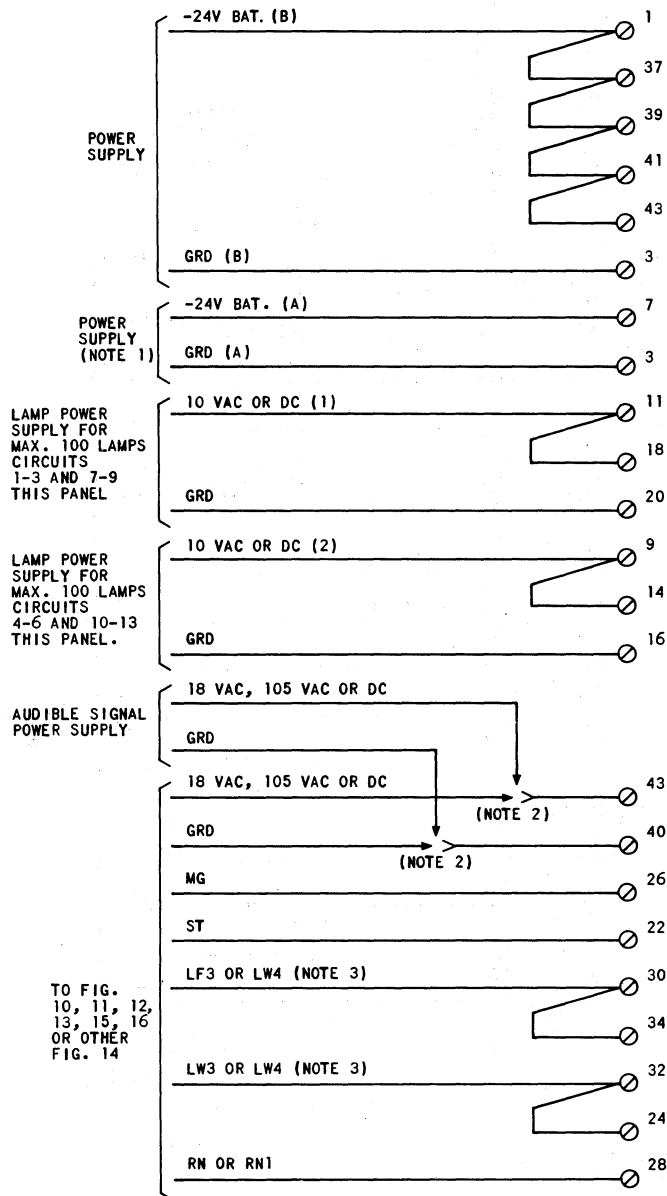

NOTES

1. PROVIDE ONLY WHEN USING KEY TELEPHONE UNITS THAT REQUIRE -24V BAT.(A), SUCH AS 401A KTU.
2. IF LEADS FROM PRECEDING PANEL ARE LOADED TO CAPACITY, PROVIDE SEPARATE AUDIBLE SIGNAL POWER TO THIS PANEL.
3. DISTRIBUTE PANELS BETWEEN LF3, LW3 OR LF4, LW4 LEADS.

Fig. 14—584C Panel Equipped With 412A KTU (Panel not used to control other panels)

584 C PANEL  
EQUIPPED WITH INTERRUPTER  
USING PROGRAM C PLUG

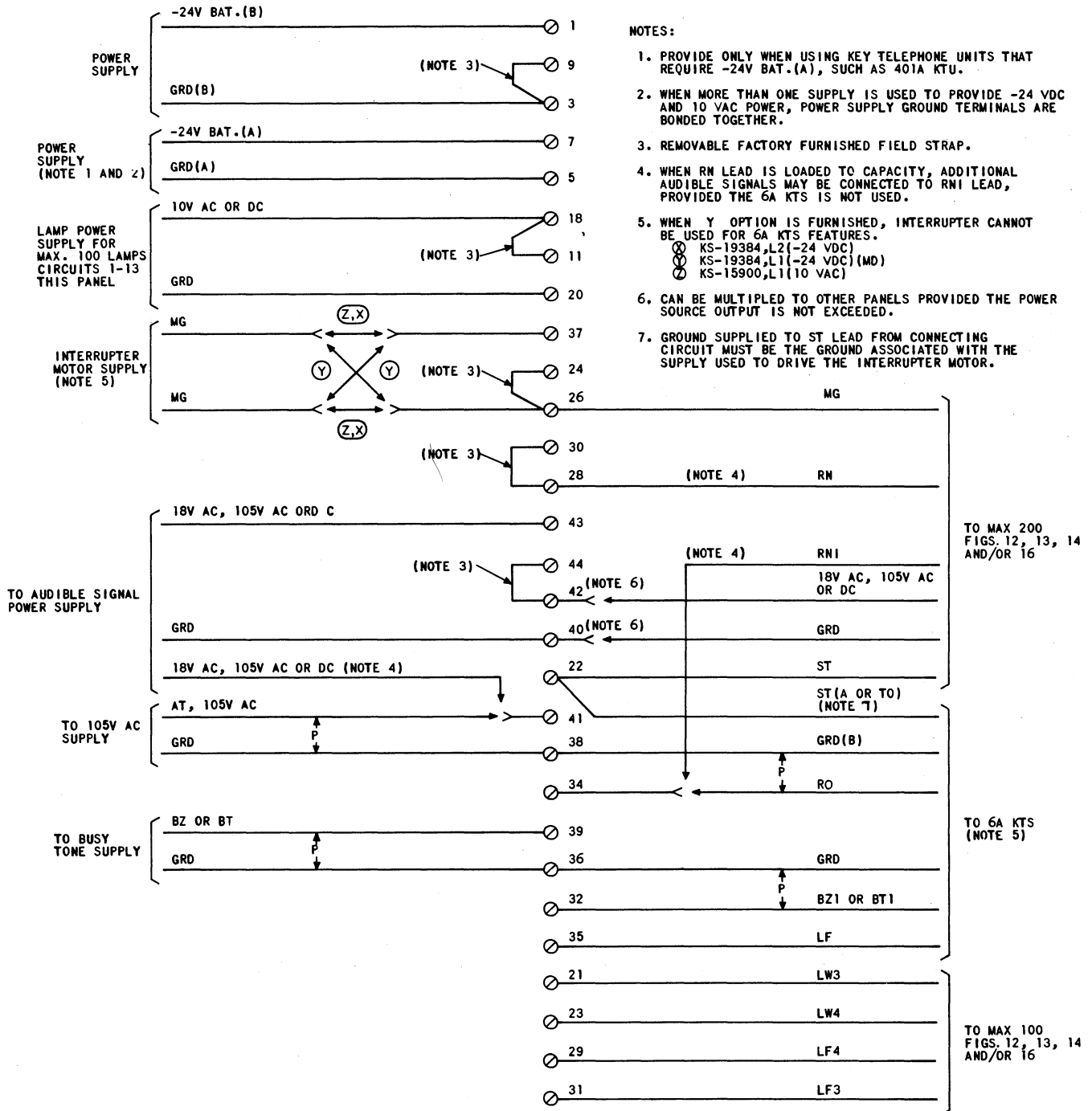

Fig. 15—584C Panel Equipped With Interrupter (Master panel used to control up to 200 other panels each equipped with 412A KTU)

SECTION 518-215-410

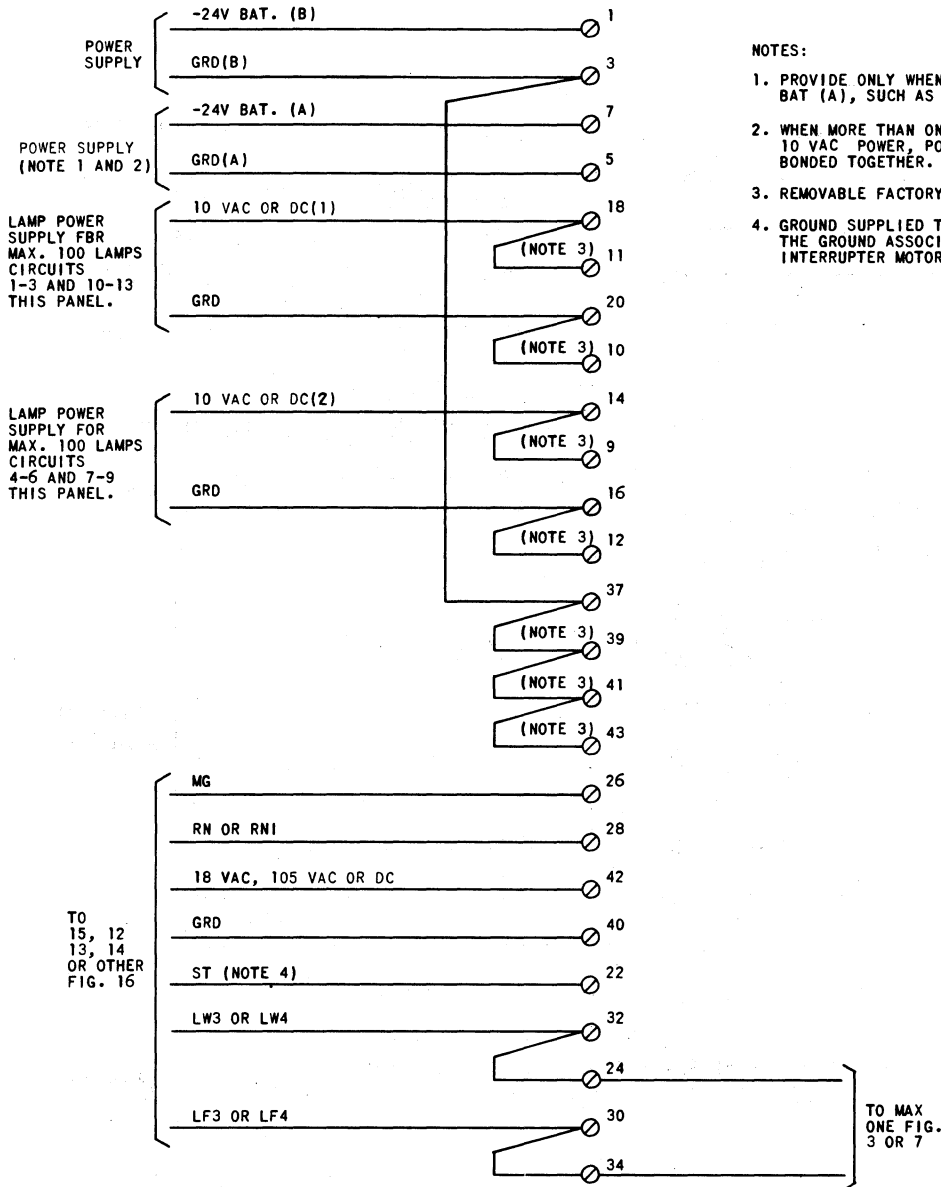

Fig. 16—584C Panel Equipped With 412A KTU (Panel used to control one other panel)

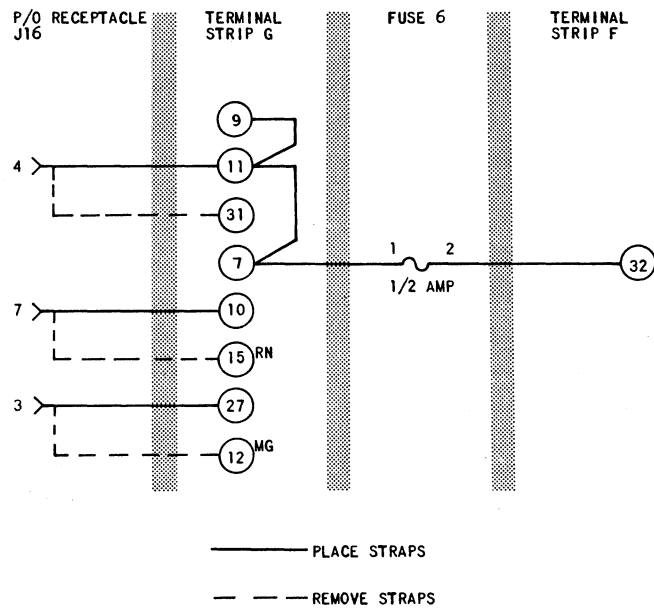
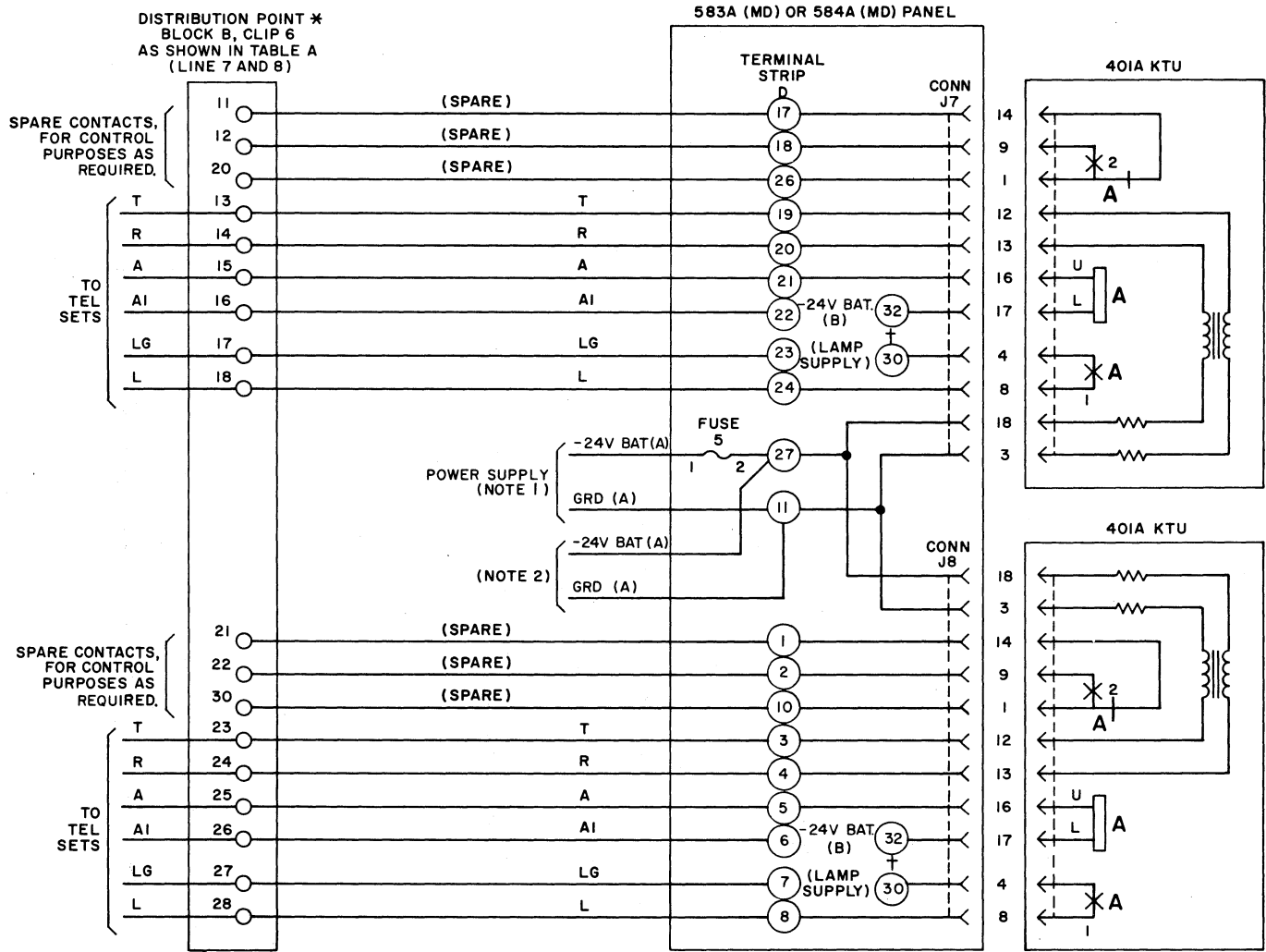

Fig. 17—Modification of 584A (MD) Panel to Accept 412A KTU

2 5 2 5

SECTION 518-215-410



NOTES:

1. A MAXIMUM OF SIX 401A KTUS CAN BE SERVED THROUGH FUSE 5. IF ADDITIONAL 401A KTUS ARE REQUIRED, -24V BAT. (A) MUST BE SUPPLIED THROUGH A SPARE FUSE.
  2. IF ADDITIONAL 401A KTUS ARE REQUIRED, MULTIPLE TO ANY DESIRED TERMINAL STRIP EXCEPT TERMINAL STRIP G (CONN J13), WITHIN THE LIMITATIONS OF NOTE 1.
- \* A MAXIMUM OF 3 STATION CABLES OR 2 STATION CABLES AND A DISTRIBUTING CABLE CAN CONNECT DIRECTLY TO PANEL.
- † FURNISHED WITH BASIC WIRING OF PANEL. FOR CLARITY, SAME TERMINAL SHOWN TWICE.

Fig. 18—Manual Intercommunication Connections for 583A (MD) and 584A (MD) Panels

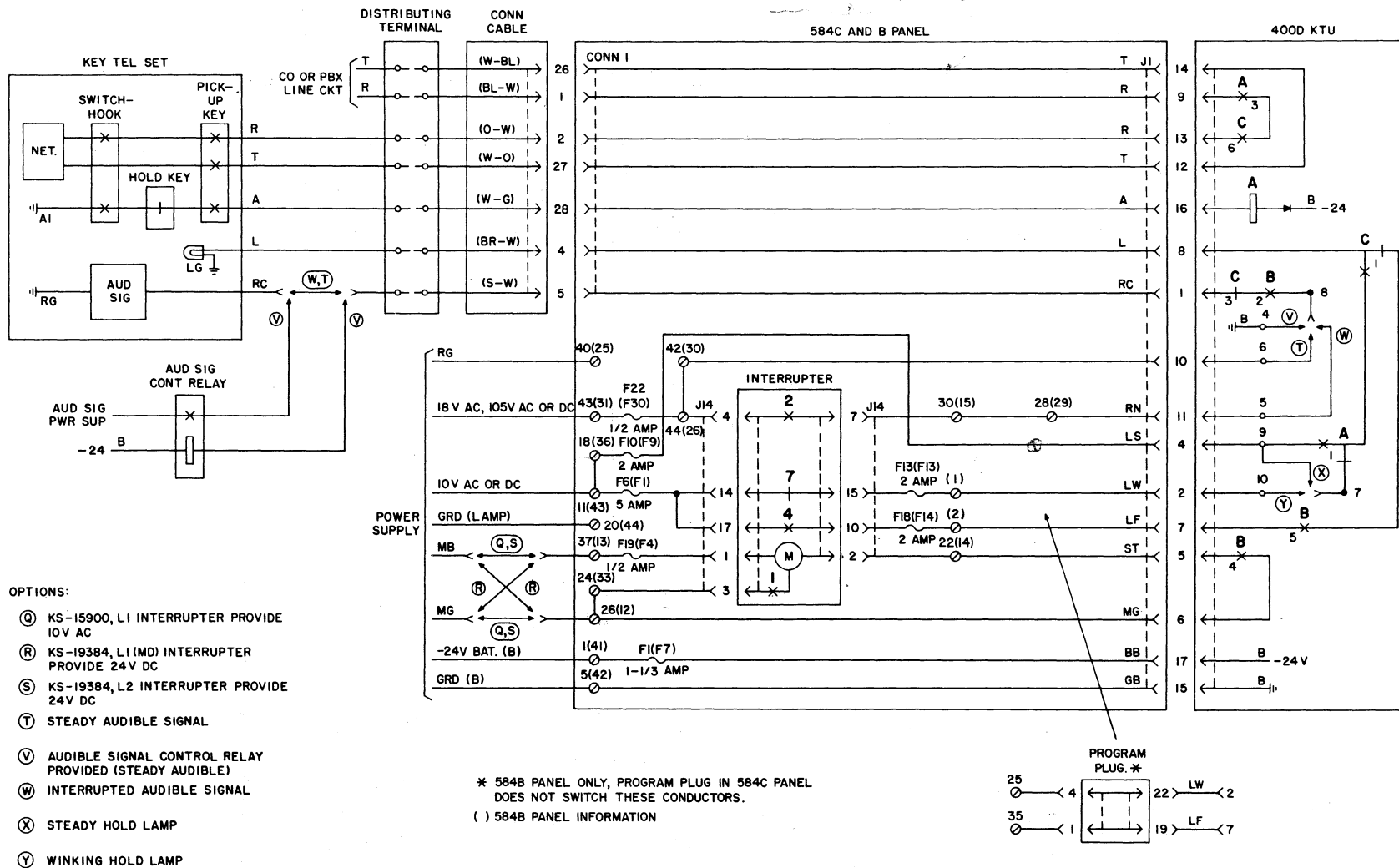

Fig. 19—Typical Functional Layout of 584C or B Panel Showing Line Circuit 1 Only

**TABLE A**  
**CONNECTIONS TO DISTRIBUTION POINT AND/OR TO THE PANELS**

CIRCUIT		LEAD DESIG	DISTRIBUTION POINT BLOCK A 66-TYPE CONNECTING BLOCK			TERMINAL ON PANEL			
			TERMINAL	CLIP	COLOR BL-W BINDER	583A	584A	584B AND 584C	
								TERMINAL	CONNECTOR
Line 1	CO PBX	T	1	6	W-BL	17A	26	1	
		R	2		BL-W	18A			1
	STA	T	3		W-O	19A	27		
		R	4		O-W	20A	2		
		A	5		W-G	21A	28		
		A1	6		G-W	22A	3		
		LG	7		W-BR	23A	29		
		L	8		BR-W	24A	4		
		RG	9		W-S	25A	30		
		RC	10		S-W	26A	5		
Line 2	CO PBX	T	11		R-BL	1A	31		
		R	12		BL-R	2A	6		
	STA	T	13		R-O	3A	32		
		R	14		O-R	4A	7		
		A	15		R-G	5A	33		
		A1	16		G-R	6A	8		
		LG	17		R-BR	7A	34		
		L	18		BR-R	8A	9		
		RG	19		R-S	9A	35		
		RC	20		S-R	10A	10		
Line 3	CO PBX	T	21		BK-BL	17B	36		
		R	22		BL-BK	18B	11		
	STA	T	23		BK-O	19B	37		
		R	24		O-BK	20B	12		
		A	25		BK-G	21B	38		
		A1	26		G-BK	22B	13		
		LG	27		BK-BR	23B	39		
		L	28		BR-BK	24B	14		
		RG	29		BK-S	25B	40		
		RC	30		S-BK	26B	15		
Line 4	CO PBX	T	31		Y-BL	1B	41		
		R	32		BL-Y	2B	16		
	STA	T	33		Y-O	3B	42		
		R	34		O-Y	4B	17		
		A	35		Y-G	5B	43		
		A1	36		G-Y	6B	18		
		LG	37		Y-BR	7B	44		
		L	38		BR-Y	8B	19		
		RG	39		Y-S	9B	45		
		RC	40		S-Y	10B	20		
Line 5	CO PBX	T	41		V-BL	17C	46		
		R	42		BL-V	18C	21		
	STA	T	43		V-O	19C	47		
		R	44		O-V	20C	22		
		A	45		V-G	21C	48		
		A1	46		G-V	22C	23		
		LG	47		V-BR	23C	49		
		L	48		BR-V	24C	24		
		RG	49		V-S	25C	50		
		RC	50		S-V	26C	25		



TABLE A (Cont)

CONNECTIONS TO DISTRIBUTION POINT AND/OR TO THE PANELS

CIRCUIT		LEAD DESIG	DISTRIBUTION POINT BLOCK B 66-TYPE CONNECTING BLOCK			TERMINAL ON PANEL			
			TERMINAL	CLIP	COLOR O-W BINDER	583A	584A	584B AND 584C	
								TERMINAL	CONNECTOR
Line 6	CO PBX	T	1	6	W-BL	1C	26	2	
		R	2		BL-W	2C	1		
	STA	T	3		W-O	3C	27		
		R	4		O-W	4C	2		
		A	5		W-G	5C	28		
		A1	6		G-W	6C	3		
		LG	7		W-BR	7C	29		
		L	8		BR-W	8C	4		
		RG	9		W-S	9C	30		
		RC	10		S-W	10C	5		
Line 7	CO PBX	T	11		R-BL	17D	31		
		R	12		BL-R	18D	6		
	STA	T	13		R-O	19D	32		
		R	14		O-R	20D	7		
		A	15		R-G	21D	33		
		A1	16		G-R	22D	8		
		LG	17		R-BR	23D	34		
		L	18		BR-R	24D	9		
		RG	19		R-S	25D	35		
		RC	20		S-R	26D	10		
Line 8	CO PBX	T	21		BK-BL	1D	36		
		R	22		BL-BK	2D	11		
	STA	T	23		BK-O	3D	37		
		R	24		O-BK	4D	12		
		A	25		BK-G	5D	38		
		A1	26		G-BK	6D	13		
		LG	27		BK-BR	7D	39		
		L	28		BR-BK	8D	14		
		RG	29		BK-S	9D	40		
		RC	30		S-BK	10D	15		
Line 9	CO PBX	T	31		Y-BL	17E	41		
		R	32		BL-Y	18E	16		
	STA	T	33		Y-O	19E	42		
		R	34		O-Y	20E	17		
		A	35		Y-G	21E	43		
		A1	36		G-Y	22E	18		
		LG	37		Y-BR	23E	44		
		L	38		BR-Y	24E	19		
		RG	39		Y-S	25E	45		
		RC	40		S-Y	26E	20		
Line 10	CO PBX	T	41		V-BL	1E	46		
		R	42		BL-V	2E	21		
	STA	T	43		V-O	3E	47		
		R	44		O-V	4E	22		
		A	45		V-G	5E	48		
		A1	46		G-V	6E	23		
		LG	47		V-BR	7E	49		
		L	48		BR-V	8E	24		
		RG	49		V-S	9E	50		
		RC	50		S-V	10E	25		

TABLE A (Cont)

CONNECTIONS TO DISTRIBUTION POINT AND/OR TO THE PANELS

CIRCUIT		LEAD DESIG	DISTRIBUTION POINT BLOCK C 66-TYPE CONNECTING BLOCK			TERMINAL ON PANEL			
			TERMINAL	CLIP	COLOR G-W BINDER	583A	584A	584B AND 584C	
								TERMINAL	CONNECTOR
Line 11	CO PBX	T	1	6	W-BL	17F		26	3
		R	2		BL-W	18F		1	
	STA	R	3		W-O	19F	27		
		R	4		O-W	20F	2		
		A	5		W-G	21F	28		
		A1	6		G-W	22F	3		
		LG	7		W-BR	23F	29		
		L	8		BR-W	24F	4		
		RG	9		W-S	25F	30		
		RC	10		S-W	26F	5		
Line 12	CO PBX	T	11		R-BL	1F	31		
		R	12		BL-R	2F	6		
	STA	T	13		R-O	4F	32		
		R	14		O-R	3F	7		
		A	15		R-G	5F	33		
		A1	16		G-R	6F	8		
		LG	17		R-BR	7F	34		
		L	18		BR-R	8F	9		
		RG	19		R-S	9F	35		
		RC	20		S-R	10F	10		
Line 13	CO PBX	T	21		BK-BL	17G	36		
		R	22		BL-BK	18G	11		
	STA	T	23		BK-O	19G	37		
		R	24		O-BK	20G	12		
		A	25		BK-G	21G	38		
		A1	26		G-BK	22G	13		
		LG	27		BK-BR	23G	39		
		L	28		BR-BK	24G	14		
		RG	29		BK-S	25G	40		
		RC	30		S-BK	26G	15		
Line 14	CO PBX	T	31		Y-BL	17H	41		
		R	32		BL-Y	18H	16		
	STA	T	33		Y-O	19H	42		
		R	34		O-Y	20H	17		
		A	35		Y-G	21H	43		
		A1	36		G-Y	22H	18		
		LG	37		Y-BR	23H	44		
		L	38		BR-Y	24H	19		
		RG	39		Y-S	25H	45		
		RC	40		S-Y	26H	20		
Line 15	CO PBX	T	41		V-BL	1H	46		
		R	42		BL-V	2H	21		
	STA	T	43		V-O	3H	47		
		R	44		O-V	4H	22		
		A	45		V-G	5H	48		
		A1	46		G-V	6H	23		
		LG	47		V-BR	7H	49		
		L	48		BR-V	8H	24		
		RG	49		V-S	9H	50		
		RC	50		S-V	10H	25		

Note: When using other than A65A connector cable with the 584B and 584C panel, these leads are spare and are dead-dressed long enough to reach any screw terminal and stored behind back panel.

2 530

(NOTE)