

**4A COMMUNICATION SYSTEM**  
**DESCRIPTION, ORDERING INFORMATION, AND OPERATION**  
**"COM KEY®" 416 KEY TELEPHONE SYSTEM**

|   | PAGE |  | PAGE |
|---|------|--|------|
| 1. GENERAL . . . . .  | 1    | CABLING RESTRICTIONS . . . . .   | 19   |
| 2. DESCRIPTION OF APPARATUS . . . . .                             | 4    | 5. METHOD OF OPERATION . . . . .   | 20   |
| BASIC FEATURES . . . . .  | 5    | ANSWERING CALLS USING HANDSET . . . . .  | 20   |
| OPTIONAL FEATURES . . . . .                                       | 6    | PLACING CALLS USING HANDSET . . . . .  | 20   |
| TELEPHONE SETS . . . . .  | 10   | HOLD OPERATION . . . . .   | 21   |
| PBX INTERFACE . . . . .   | 12   | ANSWERING CALLS USING BUILT-IN SPEAK-<br>ERPHONE (BIS) . . . . .   | 21   |
| FEDERAL COMMUNICATIONS COMMISSION<br>(FCC) REGISTRATION . . . . . | 12   | PLACING CALLS USING BUILT-IN SPEAKER-<br>PHONE . . . . .   | 22   |
| 3. ORDERING GUIDE . . . . .                                       | 12   | Built-In Speakerphone Operating Fea-<br>tures . . . . .  | 22   |
| A. Telephone Sets . . . . .                                       | 12   | ANSWERING INTERCOM CALLS AT HANDS-<br>FREE ANSWER ON INTERCOM (HFAI) STA-<br>TION . . . . .  | 22   |
| B. Optional Apparatus . . . . .                                   | 14   | HFAI OPERATING FEATURES . . . . .  | 23   |
| C. Optional Components . . . . .                                  | 15   | CALLING AN HFAI STATION . . . . .  | 23   |
| D. Interconnection Components . . . . .                           | 16   | 4A SPEAKERPHONE OPERATION . . . . .  | 23   |
| E. Replaceable Components . . . . .                               | 16   | MISCELLANEOUS OPERATING TECHNIQUES<br>. . . . .  | 24   |
| 4. INSTALLATION . . . . .   | 18   |  |      |
| PLANNING . . . . .  | 18   | 1. GENERAL   |      |
| ELECTRICAL PROTECTION . . . . .                                   | 18   | 1.01 This section contains descriptive, ordering,<br>and operation information for the 4A Commu-<br>nication System. Installation, connection, and main-<br>tenance information is now contained in Task<br>Oriented Practice (TOP) 518-450-107. |      |
| ELECTRO-MAGNETIC INTERFERENCE (EMI)<br>. . . . .                  | 18   |  |      |
| POWER REQUIREMENTS . . . . .                                      | 18   |  |      |
| Supplementary Power . . . . .                                     | 19   |  |      |

**NOTICE**  
Not for use or disclosure outside the  
Bell System except under written agreement

**Caution:** *The 4A System is designed to operate on CO/PBX loops of 20 milliamperes or greater. The 4A System is not intended for installations where off-premises extensions are required.*

**Warning:** *This equipment generates, uses, and can radiate radio frequency energy and if not installed and used in accordance with the instructions manual, may cause interference to radio communications. It has been tested and found to comply with the limits for a Class A computing device pursuant to Subpart J of Part 15 of Federal Communication Commission (FCC) rules, which are designed to provide reasonable protection against such interference when operated in a commercial environment. Operation of this equipment in a residential area is likely to cause interference in which case the user at his own expense will be required to take whatever measures may be required to correct the interference.*

**1.02** This section is reissued to remove the information relating to installation, connections, and maintenance. Since this reissue is a general revision, no revision arrows have been used to denote significant changes.

**1.03** The 4A System is a packaged, modular key telephone system having a maximum capacity of 16 stations with four common CO/PBX lines, one personal CO/PBX line per telephone, and two intercom paths. A wide selection of basic and optional features is available. The system includes five types of telephones: (1) primary sets, (2) basic satellite desk sets, (3) basic satellite wall sets, (4) satellite sets with built-in speakerphone (BIS), and (5) satellite sets with hands-free answer on intercom (HFAI). Each primary set contains the control circuitry for two CO/PBX lines and one intercom path and the power circuitry to serve itself and some combination of up to seven satellite sets. The addition of a second primary set doubles the capacity of the system; up to seven more satellite sets can be connected, with each station in the system now served by up to four CO/PBX lines and two intercom paths. The satellite sets provide the same basic services as the primary sets, but they do not contain control and power circuits.

**1.04** Because the control and power circuitry of the 4A System is contained in the primary station

sets, there is no need for separately mounted key service units such as most key systems require. The only equipment required in addition to the telephone sets are interconnecting cables, blocks, adapters, and small externally mounted units for some optional features. Systems with many optional features may require an externally mounted power unit.

**1.05** Each 4A station can be programmed by the customer to ring on any combination of the common CO/PBX lines. All stations have access to all common lines in the system; therefore, any set can be assigned as the attendant station, if one is required. Each station also has direct access to the ten intercom codes.

**1.06** All 4A telephone sets are available with either rotary or TOUCH-TONE® dialing. The primary set is available only in a desk-type model, but the basic satellite sets can be ordered in both desk and wall configurations. The BIS and HFAI sets are convertible from desk to wall mounting by means of a kit of parts. There are a total of ten telephone set codes in the 980-series (Table A). Figures 1 through 5 illustrate typical sets.

**1.07** The 4A System derives its ac power from a standard 117-volt 60-Hz source. The system components are protected by a self-resetting thermal cutout in the power supply of the primary station, making separate fusing unnecessary. The 19B4 power unit, used when supplementary dc power is required, has both input and output fusing.

**1.08** While the 980-series telephones provide more optional features than the 830 series manufacture discontinued (MD) used with the earlier 4A System the two series are compatible and interchangeable. They can coexist in the same system and 980-series sets can be used to replace 830-series sets in existing installations. However, if supplementary power is required, the primary sets must be from the 980 series.

**Note:** In a mixed system, optional code busy direct station selection (DSS) keys can only give busy indications for 980-series telephones.

**1.09** Certain components and apparatus used with the 4A System have been rated MD and replaced by new units. These units are listed in Table B. Throughout the rest of this practice, all references will be to the current versions of the units, **unless**

**TABLE A**  
**SUMMARY OF 4A COMMUNICATION SYSTEM TELEPHONE SETS AND OPTIONS**

| OPTIONS                             |   | COMPONENT(S) REQUIRED                                    | TELEPHONE SETS  |                            |                            |                  |                   |
|-------------------------------------|---|--|-----------------|----------------------------|----------------------------|------------------|-------------------|
|                                     |   |  | DESK<br>PRIMARY | BASIC<br>DESK<br>SATELLITE | BASIC<br>WALL<br>SATELLITE | BIS<br>SATELLITE | HFAI<br>SATELLITE |
|                                     |   |  | 981A01          | 981A02                     | 981A03                     | 983A01           | 983A02            |
|                                     |   |  | 2981A01         | 2981A02                    | 2981A03                    | 2983A01          | 2983A02           |
| Set<br>Options                      | Personal Line                                 | 30AM Apparatus Unit*<br>D-180758 Kit of Parts            | •               | •                          | •                          | •                | •                 |
|                                     | Privacy                                       | D-180729 Kit of Parts                                    | •               | •                          | •                          | •                | •                 |
|                                     | Wall Mounting                                 | D-180747 Kit of Parts                                    |                 |                            |                            | •                | •                 |
|                                     | Code Busy DSS Key                             | 664C Key   | •               | •                          | •                          | •                | •                 |
|                                     | Station Restriction                           | (Wiring Change Only)                                     | •               | •                          | •                          | •                | •                 |
|                                     | Impaired Hearing<br>Handset                   | G6BM Handset<br>D-180851 Kit of Parts                    | •               | •                          |                            | †                | †                 |
|                                     | Handset With More<br>Receive Gain Than G6BM   | D-180413 Handset<br>D-180851 Kit of Parts                | •               | •                          |                            | †                | †                 |
|                                     | Weak Speech Handset                           | G7BM Handset<br>D-180851 Kit of Parts                    | •               | •                          |                            | †                | †                 |
|                                     | Noisy Location Handset                        | G8BM Handset<br>D-180851 Kit of Parts                    | •               | •                          |                            | †                | †                 |
|                                     | Acoustic or Inductive<br>Coupling Handset     | G15A Handset<br>D-180851 Kit of Parts                    | •               | •                          |                            | †                | †                 |
|                                     | G-Type Handset Equipped<br>With Shoulder Rest | G4BM Handset<br>D-180851 Kit of Parts                    | •               | •                          |                            | †                | †                 |
|                                     | Long Loop, 3-dB Transmit<br>Gain              | G36AM Handset<br>D-180851 Kit of Parts                   | •               | •                          |                            | †                | †                 |
|                                     | External Speakerphone                         | 4A Speakerphone<br>D-180732 Kit of Parts                 |                 |                            |                            |                  | †                 |
|                                     | Repertory Dialing                             | Adjunct Repertory Dial<br>870A1 or 2870A1<br>D10Y50 Cord |                 | •                          |                            | †                | †                 |
|                                     | Built-In Speakerphone                         | (Factory-Installed)                                      |                 |                            |                            | •                |                   |
| Hands-Free Answering<br>on Intercom | (Factory-Installed)                           |  |                 |                            |                            | •                |                   |

See footnotes at end of table.

the procedures applying to the MD unit are different in any way; in the latter case, both units will be given separate coverage.

**1.10** Schematics of the telephone sets and apparatus units of the 4A System are contained in SD-69856-01. The schematic of the 1A transmitter-

receiver (built-in speakerphone module) is in SD-69800-01.

**1.11** For additional information on the following subjects, refer to the documents listed:

4A Speakerphone—Section 512-700-100

TABLE A (Contd)

## SUMMARY OF 4A COMMUNICATION SYSTEM TELEPHONE SETS AND OPTIONS

| OPTIONS           |  | COMPONENT(S) REQUIRED   | TELEPHONE SETS  |                            |                            |                  |                   |
|-------------------|--|---|-----------------|----------------------------|----------------------------|------------------|-------------------|
|                   |  |   | DESK<br>PRIMARY | BASIC<br>DESK<br>SATELLITE | BASIC<br>WALL<br>SATELLITE | BIS<br>SATELLITE | HFAI<br>SATELLITE |
|                   |  |   | 981A01          | 981A02                     | 981A03                     | 983A01           | 983A02            |
|                   |  |   | 2981A01         | 2981A02                    | 2981A03                    | 2983A01          | 2983A02           |
| System<br>Options | Power Failure Ringing                        | 24B Apparatus Unit  |                 |                            |                            |                  |                   |
|                   | Supplementary Alerting<br>Device Access      | 25A Apparatus Unit<br>KS-16626, L12 Relay<br>or<br>KS-16301, L17 Relay<br>Alerting Device and its<br>Power Unit |                 |                            |                            |                  |                   |
|                   | Preset Intercom Voice<br>Signaling           | 26A Apparatus Unit  |                 |                            |                            |                  |                   |
|                   | Telephone Company-<br>Provided Paging System | 109A Loudspeaker Set  |                 |                            |                            |                  |                   |
|                   | Customer-Provided Paging<br>System Interface | 27A Apparatus Unit†   |                 |                            |                            |                  |                   |
|                   | Background Music With Any<br>Paging System   | 33C Voice Coupler‡  |                 |                            |                            |                  |                   |
|                   | Music-on-Hold                                | 33C Voice Coupler‡<br>D-180980 Kit of Parts   | •               |                            |                            |                  |                   |
|                   | Tone-on-Hold                                 | D-180731 Kit of Parts   | •               |                            |                            |                  |                   |
|                   | External Ringing                             | E1CM, S1AMP, L1AM (MD),<br>or L1AMP Ringer  |                 |                            |                            |                  |                   |
|                   | Supplementary Power                          | 19B4 Power Unit   |                 |                            |                            |                  |                   |

\* Mounted external to telephone set.

† Option not offered when set is wall mounted.

‡ KS-16626L12 relay may also be required.

§ Only one 33C voice coupler is required per system.

33C Voice Coupler—Section 463-341-102

Adjunct Repertory Dials—Section 501-164-201

KS-16301L17 Relay—Section 463-110-100

KS-16626L12 Relay Set—Section 463-120-100

19B4 Power Unit—Section 167-440-201

Wall-Mounting Fasteners—Section  
080-720-105

E1-Type Ringers—Section 501-251-100

L1AM Ringer—Section 501-258-101

S1AMP Tone Ringer—Section 501-260-100

Electro-Magnetic Interference Protection—  
X-4235

## 2. DESCRIPTION OF APPARATUS

2.01 The 4A System consists primarily of key telephone sets and various connecting hardware

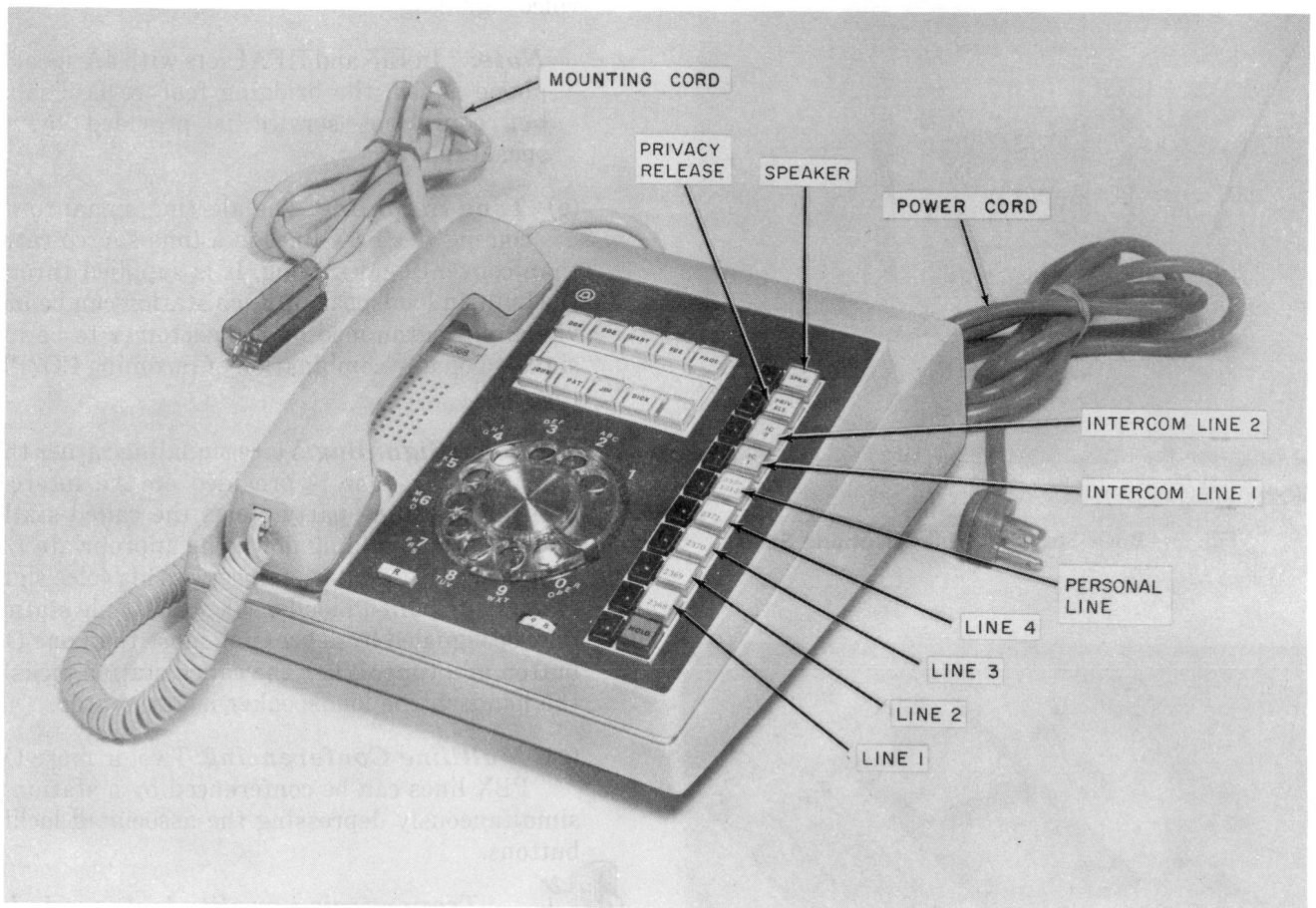

Fig. 1 — Primary Telephone Set

and cables. Basic operating features are supplied as part of the telephone sets, while additional apparatus, installed in the sets or externally, provides optional features.

#### BASIC FEATURES

**2.02** The following features are provided in all 4A System telephone sets and require no additional installation:

(a) **Pickup, Hold, and Illumination:** Standard key system pickup, hold, and line status lamp indications, including flash on incoming CO/PBX line calls, steady on answered calls, and wink-on-hold are provided. Systems with one primary set are limited to two common CO/PBX lines; systems with two primary sets can have up to four lines.

(b) **2-Path Intercom With DSS:** Two paths are provided for intercom calls, each associated with an IC button in the pickup key. A busy path is indicated by a steady lamp adjacent to the IC button. The DSS buttons allow one-way voice signaling of called stations without dialing. A two-way conversation is established when the called party goes off-hook and picks up the intercom path. Ten DSS codes are available; in systems with more than ten stations, codes must be shared. The intercom code is set at each station by means of a programming switch and may be reprogrammed by the customer. Systems with one primary set are limited to a single intercom path; systems with two primary sets have two paths.

(c) **Automatic Button Restoration (ABR):** Depressed line buttons are mechanically returned to the unoperated position when the hand-



Fig. 2—Basic Satellite Wall Telephone Set

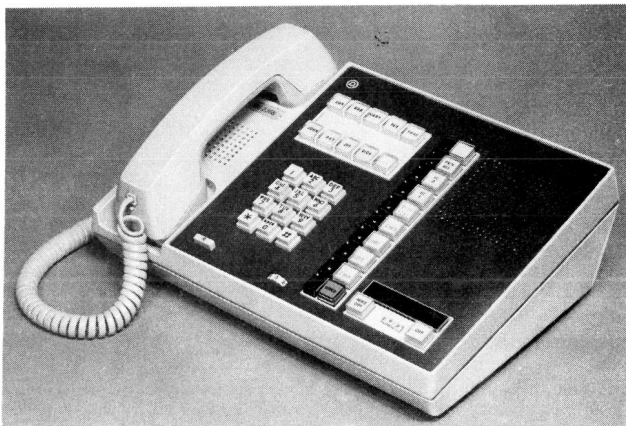

Fig. 3—Built-In Speakerphone (BIS) Satellite Telephone Set

set is placed on-hook. This prevents inadvertent intrusion into calls in progress when handset is picked up and prevents lines from being left bridged after a conference call.

(d) **Built-In Loudspeaker:** The built-in loudspeaker is bridged across the handset receiver when the locking SPKR button is operated, permitting other people in the area to hear both sides of a conversation. The loudspeaker has a thumbwheel volume control on the front of the

telephone. This loudspeaker also receives tone and voice signaling.

**Note:** In BIS and HFAI sets with 4A speakerphone added, the bridging feature is disabled but equivalent service is provided by the speakerphone.

(e) **Tone Signaling:** The alerting signal for incoming CO/PBX lines is a tone source rather than conventional ringing. It is supplied through the built-in loudspeaker. Each station can be individually programmed by the customer to be tone signaled on any combination of incoming CO/PBX lines.

(f) **Voice Signaling:** Voice signaling rather than ringing or tone is provided on the intercom paths. The calling party alerts the called station by voice while holding down the appropriate DSS button. The called station receives this voice signal through its built-in loudspeaker. Multiple stations may be signaled by depressing more than one DSS button at a time. When the called station picks up the handset, the loudspeaker is attenuated.

(g) **Multiline Conferencing:** Two or more CO/PBX lines can be conferenced by a station by simultaneously depressing the associated locking buttons.



**Transmission quality is degraded as more lines are added.**

**Note:** Intercom lines cannot be conferenced with CO/PBX lines.

(h) **Recall**—The R button, located below and to the left of the dial on each set, has two functions: (1) to drop a line and reoriginate dial tone without going back on-hook and (2) to signal [flash] the attendant when the 4A System is behind a PBX or Centrex. The R button should be used for these operations instead of depressing the switchhook which will cause the line or intercom buttons to restore.

(i) **Outgoing Service During Power Failure:** Outgoing CO/PBX calls can be made from the 4A System even when local power has failed.

#### OPTIONAL FEATURES

**2.03** The following options are available as separately installed items or as features of specific telephones:

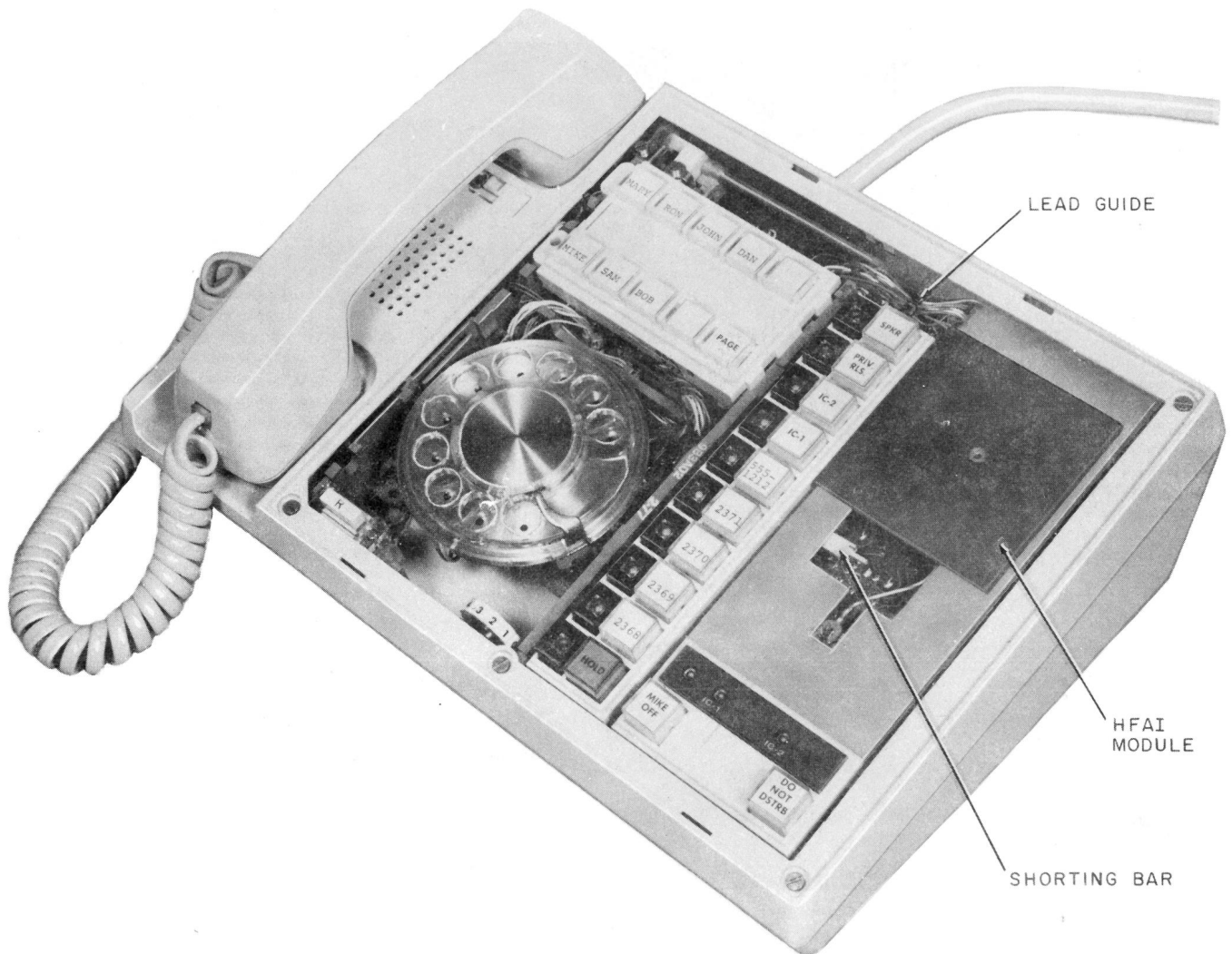

**Fig. 4—Hands-Free Answer on Intercom (HFAI) Satellite Telephone Set With Faceplate Removed**

(a) **Personal Line:** Each station in the 4A System can be provided with one noncommon, personal CO/PBX line. Each such line requires the installation of a separately mounted 30AM apparatus unit which provides standard key system pickup, hold, and line status lamp indications for that line. The personal line is assigned to a button in the line pickup key. A given personal line may be shared by more than one station in the system, and it will ring at every station where it is connected. Music- or tone-on-hold is available as an option with this feature.

(b) **TOUCH-TONE Dialing:** Rotary dialing can be replaced by TOUCH-TONE dialing by ordering appropriate telephone codes. Rotary dial and TOUCH-TONE\* telephone dial sets may be intermixed in the 4A System without additional equipment.

(c) **Privacy/Privacy Release:** A station equipped with the optional privacy feature is prevented from entering a CO/PBX call in progress. Privacy is implemented on a per-station basis

\*Trademark.



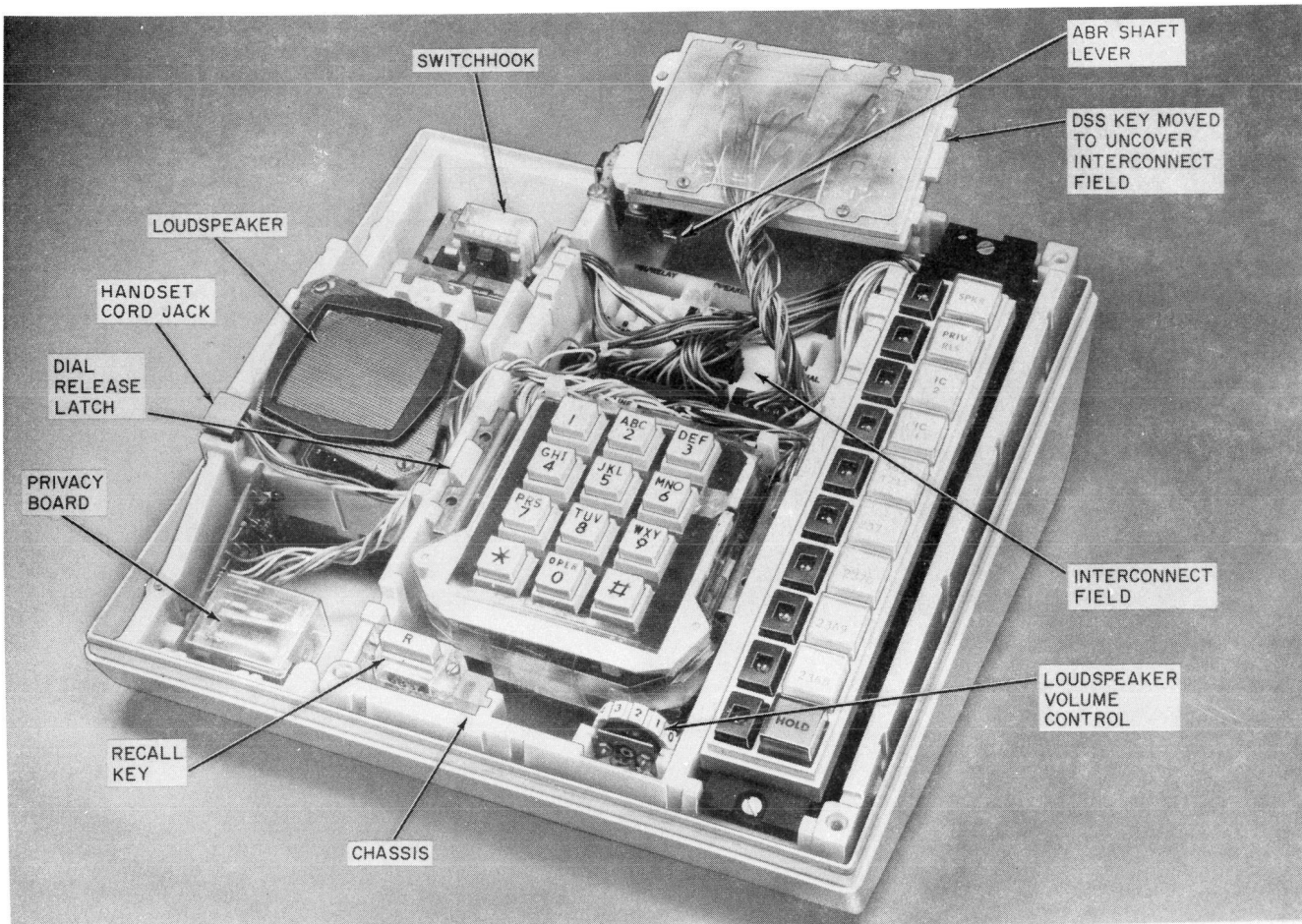

Fig. 5—Basic Satellite Desk Set With Faceplate and Upper Housing Removed

by installation of a D-180729 Kit of Parts. The station can be released from this condition by the operation of the privacy release feature at the *other* station(s) on the call. All 980-series telephone sets have the factory-wired PRIV RLS button, which should be designated only when at least one station in the system has privacy installed.

**Note:** The privacy feature applies to all CO/PBX lines but not to intercom lines.

(d) **Station Restriction:** Placing of all outgoing CO/PBX calls from a station can be prevented by shorting bar changes inside the set.

(e) **Music-on-Hold:** Music from customer-provided music source is supplied to CO/PBX lines placed on hold. Installation of one 33C Voice

Coupler per system and a separate D-180980 Kit of Parts in each primary station and each 30AM apparatus unit is required.

(f) **Tone-on-Hold:** An alternative to music-on-hold, it provides intermittent bursts of tone to CO/PBX lines placed on hold. Installation of a D-180731 Kit of Parts in each primary station and each 30AM apparatus unit is required.

(g) **Supplementary Alerting Device Access:** The operation of an external relay to control bells, gongs, horns, etc, by incoming ringing on CO/PBX lines and/or by depression of an assigned DSS button is provided. This feature requires installation of a 25A apparatus unit, an external relay, and a signal with its power source.



TABLE B

## STATUS OF MANUFACTURE DISCONTINUED (MD) COMPONENTS AND APPARATUS

| MD UNIT                             | REPLACED BY | REASON FOR CHANGE                               | APPLICATION OF MD UNIT                                   |
|-------------------------------------|-------------|---|--|
| 91A Connecting Block                | 91B         | Meet FCC Registration Requirements in 4A System | None, use 91B connecting block in all new installations. |
| 24A Apparatus Unit                  | 24B         | Meet FCC Registration Requirements in 4A System | Previously used unit can be reused in any installation   |
| 30A Apparatus Unit                  | 30AM        | Meet FCC Registration Requirements in 4A System | Previously used unit can be reused in any installation   |
| 33A Voice Coupler                   | 33C         | Meet FCC Registration Requirements in 4A System | Previously used unit can be reused in any installation   |
| D-180730 Music-On-Hold Kit of Parts | D-180980    | Meet FCC Registration Requirements in 4A System | Previously used unit can be reused in any installation   |
| 19B2 Power Unit                     | 19B4        | Meet New Underwriters Laboratories Standards    | Any installation   |
| 2012B Transformer                   | 2012D       | Design Improvement                              | Any installation   |

(h) **Paging:** Voice announcements can be made over 109A loudspeaker sets or a customer-owned and maintained paging system. The latter arrangement requires the use of a 27A apparatus unit to provide proper interface with the 4A System. Background music may be provided by means of customer-provided music and a 33C voice coupler (same source and coupler used for music-on-hold). The paging path is activated by operation of a DSS button assigned to this feature. The 109A loudspeaker contains two customer-accessible volume controls for adjusting background music and paging volume; background music is automatically muted during paging.

**Note:** For normal voice inputs, the minimum output of the 27A apparatus unit is -30 dBm into 600 ohms.

(i) **Preset Intercom Multiple Voice Signaling:** Allows any number of preselected stations and/or paging loudspeakers to be voice signaled simultaneously by means of a designated DSS button. A 26A apparatus unit is required for this feature.



**Remember that a DSS code used for supplementary signaling, paging, or preset intercom signaling is no longer available as a station code.**

(j) **Code Busy DSS Key:** Lamps in this DSS key indicate that one or more stations assigned to a DSS code are off-hook or being voice signaled. This feature can be implemented on a per-station basis by replacing the factory-installed DSS key with an identical size 664C key which contains LEDs.

**Note:** In systems where 980-series sets are mixed with 830-series sets, the 664C key will indicate busy 980-series sets only.

(k) **Power Failure Ringing:** The 24B apparatus unit provides two C4B ringers and associated circuitry to connect the ringers to the CO/PBX lines in the event ac power to the 4A System fails. Installation of a 24B for each primary station is required.

(l) **Hands-Free Answer on Intercom:** The HFAI is available only as a built-in feature of two 4A telephones (983A02 and 2983A02). It allows incoming intercom calls to be answered without any manual action by the called party; the microphone in the HFAI is turned on by the incoming call. The HFAI station user can operate a "mike-off" button to disable the microphone while still receiving voice signaling or use a "do-not-disturb" button to both disable the microphone and block voice signaling.

(m) **Speakerphone:** Speakerphone service permits hands-free conversations on CO/PBX and intercom lines and is available in the 4A System in two configurations only.

(1) Built-in speakerphone telephone sets (983A01 and 2983A01).

(2) An external 4A speakerphone connected to the HFAI telephone set. The installation of a D-180732 relay Kit of Parts is required. The 4A speakerphone cannot be used with any other 4A System telephone sets.



**In all telephones with speakerphone, the ability to bridge the set loudspeaker across the incoming line with the SPKR button is disabled.**

(n) **Repertory Dialing:** This feature is provided by connection of an 870A1 (rotary dial) or 2870A1 (TOUCH-TONE telephone dial) adjunct repertory dial with a D10Y-50 cord to desk models of satellite telephone sets. It allows numbers stored in the dial memory to be called by the operation of a single button.

(o) **Supplementary Power:** A 19B4 power unit can be used to increase the basic power capac-

ity of the 4A System and to compensate for the additional power required for HFAI sets, code busy DSS keys, and 109A paging loudspeakers. If any of these optional features are employed in the 4A System, supplementary power may be required.

**Note:** The 19B4 power unit supplies only 24-volt battery to the 4A System. The built-in power supplies in the primary sets continue to provide lamp power to the system and control circuit power to the primary sets when a 19B4 is connected.

(p) **External Ringing:** This feature is provided by connecting an external ringer (such as an E1CM, S1AMP, or L1AM) across the CO/PBX tip and ring leads at the network interface.

(q) **Special Purpose Handsets:** The K2C-50 handset supplied with each 4A System desk telephone can be removed and replaced with a standard G4 or G15 handset or with one designed for long loop, handicapped users, or noisy locations. A D-180851 Kit of Parts must be installed on the new handset to adapt it to the 4A System telephone. See Table A or paragraph 3.04(f) for handset used for special application.

## TELEPHONE SETS

**2.04** The 980-series telephone sets are completely new in design; all components are connected by means of plugs and jacks for quick assembly and replacement. Primary and basic satellite sets are packaged in housings of the same width, but the primary sets are somewhat deeper because of the control and power circuitry they contain. The BIS and HFAI satellite sets require a wider housing to accommodate their additional features.

**2.05** The basic features described in paragraph 2.02 appear in all sets. The 663A2 line key contains ten buttons—hold, four common CO/PBX lines, an optional personal line, two intercom paths, an optional privacy release, and built-in loudspeaker on/off control. The LED status lamps are associated with each line and intercom path button. The 664B DSS key consists of two horizontal rows of five buttons, each of which may be assigned to one or more stations, a paging loudspeaker, supplementary ringing or preset multiple signaling. Between the two rows of DSS buttons and under a hinged cover are the

programming switches for DSS code assignment and CO/PBX line ringing control. The built-in loud-speaker is located under the handset, and its volume control is below and to the right of the dial. The recall (R) key is below and to the left of the dial. All sets employ the K1C modular handset. The rotary dial is standard, but the TOUCH-TONE telephone dial is available.

**2.06** The internal arrangement of the telephones is based on the use of a molded plastic chassis to which the components of the set are attached and an electrical interconnect field into which the components are plugged (Fig. 5). The interconnect field also contains positions for plugging in optional features and switches a through h for adapting the set to options. Outside connections are made by way of the set mounting cord or separate cords for such optional features as personal lines, 4A speakerphone, and repertory dialing. In primary sets (Fig. 6), the mounting

cord plugs into a wiring harness which distributes leads to the line key and the control logic board. In the other desk-type sets, the mounting cord plugs directly into the line key. The system connector cable is intended to be plugged directly into the wall sets without the use of mounting cords, which are not supplied with wall sets.

**2.07** Mounted on the base of each primary set is a logic board containing control and power circuitry for two CO/PBX lines and one intercom path, and a transformer for supplying ac power to the logic board (Fig. 6). Up to seven satellite telephones can derive their power from one primary set. Each primary set contains a polarity guard circuit which prevents battery reversals on the CO/PBX lines from interfering with TOUCH-TONE calling and multi-line conferencing.

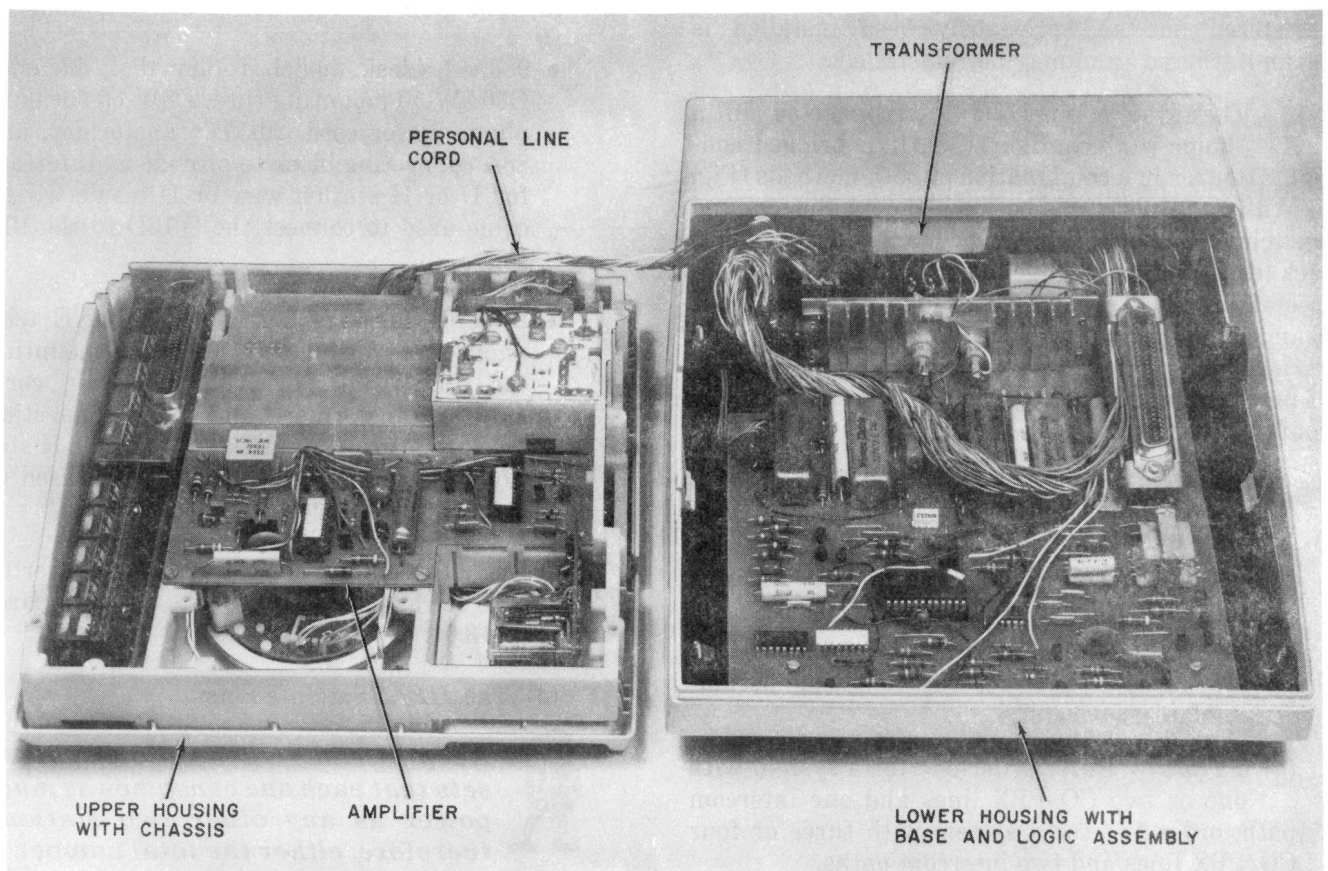

Fig. 6—Primary Set Disassembled

**PBX INTERFACE**

**2.08** The 4A System will interface with all PBXs except that it cannot provide for ground-start operation of CO trunks which bypass the PBX in the event of PBX power failure. In all other respects, the system performs on PBX lines in the same manner as on CO lines. For PBX use, the only restriction on the number of telephone sets is that each 25-pair connector cable system can serve a maximum of 2 primary stations and 14 satellite stations. Although 4A telephone sets behind a PBX have full capabilities, they can contact telephones in other systems only via PBX lines. To signal the PBX operator, the recall button must be used.

**FEDERAL COMMUNICATIONS COMMISSION (FCC) REGISTRATION**

**2.09** The 4A System was tested per, and complies with, the rules and regulations in Subpart D of Part 68 of the FCC rules. The FCC has defined a register-only date after which new product, which is registered, can be installed. Old product which is not registered but had previously been installed is "grandfathered" and may be reinstalled.

**2.10** The system may be interconnected in a "home-run" configuration, in a bridged configuration, or in a combination of both methods (Fig. 7). All interconnections between the 4A System and the telephone network must be made via a standard jack (eg, RJ11C or RJ14C) and fully protected premises wiring. The type of network address signaling is E and the ringer equivalence number for the system varies from one to five as a function of the number of power failure ringer apparatus units a particular configuration contains.

**3. ORDERING GUIDE****A. Telephone Sets**

**3.01** Order the required telephone sets from the following list. Sets are supplied in ivory only and are shipped with E-6723 key designation tabs and disposable faceplates. Order the following permanent faceplates separately:

(a) **Primary Sets:** Order one for a system with one or two CO/PBX lines and one intercom path; order two for a system with three or four CO/PBX lines and two intercom paths.

- 981A01 (desk model, rotary dial; includes D50AB-50 mounting cord)

- 2981A01 (desk model, TOUCH-TONE telephone set; includes D50AB-50 mounting cord).

(b) **Satellite Sets:** Order as required.

(1) Basic Satellite **Desk** Sets:

- 981A02 (desk model, rotary dial; includes D50AW-50 mounting cord)
- 2981A02 (desk model, TOUCH-TONE telephone set; includes D50AW-50 mounting cord).

(2) Basic Satellite **Wall** Sets:

- 981A03 (wall model, rotary dial; mounting cord not included)
- 2981A03 (wall model, TOUCH-TONE telephone set; mounting cord not included).

(3) The **BIS** Satellite Sets:

- 983A01 (desk model, rotary dial; includes D50AW-50 mounting cord, D8W-50 speakerphone power cord, 2012D transformer, and 86A connecting block to provide an interface for D or H station wire or D inside wiring cable used to connect the 2012D to the BIS set)
- 2983A01 (desk model, TOUCH-TONE telephone set; includes D50AW-50 mounting cord, D8W-50 speakerphone power cord, 2012D transformer, and 86A connecting block to provide an interface for D or H station voice or D inside wiring cable used to connect the 2012D to the BIS set).

**Note:** Desk model of BIS set can be converted to wall set by use of kit of parts listed in paragraph 3.04.

(4) The **HFAI** Satellite Sets:



**Keep in mind when ordering HFAI sets that each one consumes as much power as any other two stations; therefore, either the total number of stations in the system may have to be reduced or supplementary power used (see paragraph 4.10).**

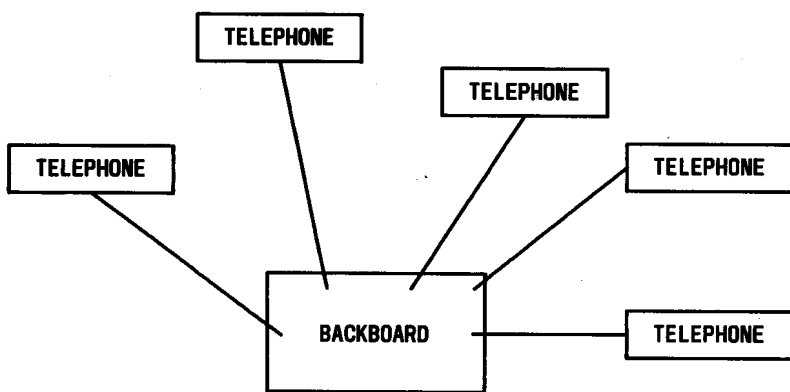

A. BASIC HOME-RUN WIRING SYSTEM

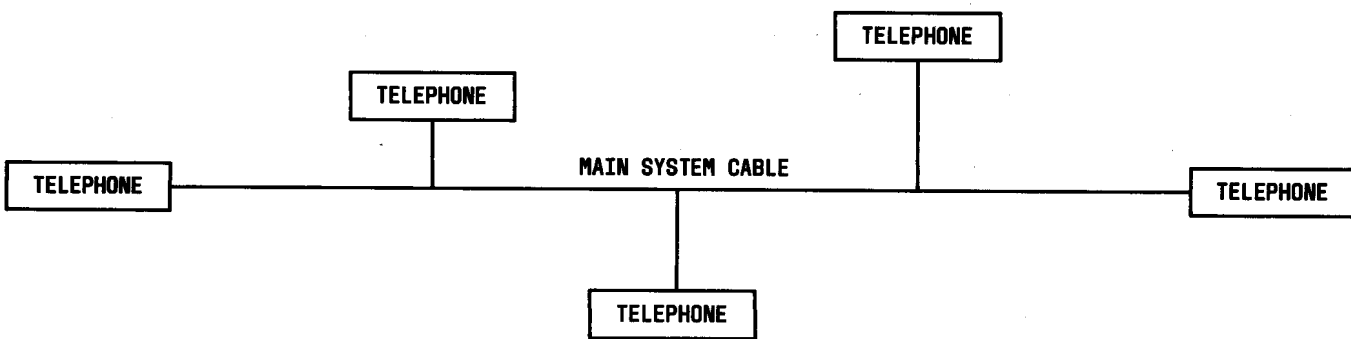

B. BASIC BRIDGED WIRING SYSTEM

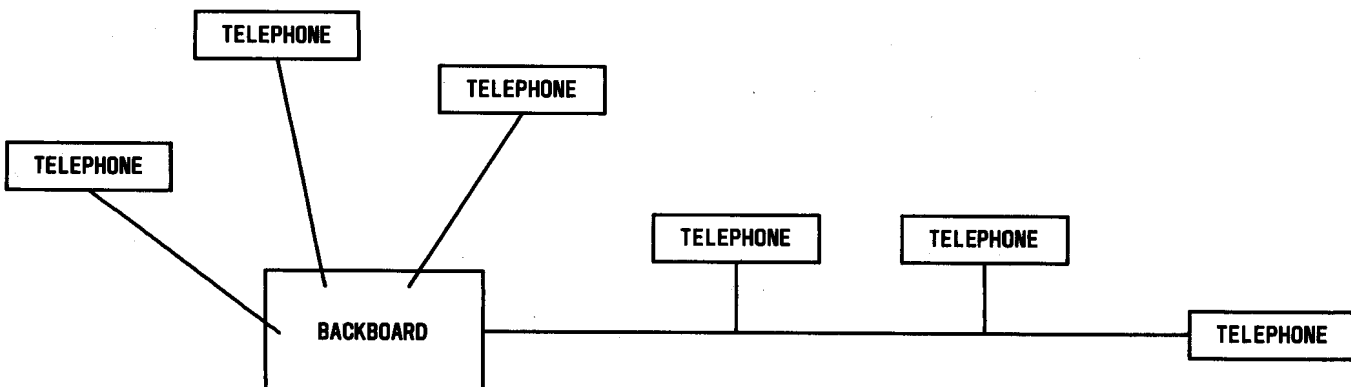

C. COMBINATION OF BRIDGED WITH HOME-RUN SYSTEM

Fig. 7—Simplified Block Diagram of Basic Wiring Methods

SECTION 518-450-106

- 983A02 (desk model, rotary dial; includes D50AW-50 mounting cord)
- 2983A02 (desk model, TOUCH-TONE telephone set; includes D50AW-50 mounting cord).

**Note:** Desk model of HFAI set can be converted to wall set by use of kit of parts listed in paragraph 3.04.

**3.02** Order the following as required depending on the types of telephones being installed:

- Block, Connecting, 91B (order one for each primary station)
- Faceplate, 61C-† (for 981-type sets)
- Faceplate, 261C-† (for 2981-type sets)
- Faceplate, 63D-† (for 983-type sets)
- Faceplate, 263D-† (for 2983-type sets)

†Add color code suffix as follows:

- Avocado (-100)
- Teak (-108)
- Walnut (-109)
- Gold (-111)
- Orange (-112)
- Brown (-113)
- Red (-114)
- Blue (-115)
- Black (-118)

**B. Optional Apparatus**

**3.03** Order the following apparatus as required to implement options (see Table A).

(a) **Personal Line:** Order as follows:

- Unit, Apparatus, 30AM (order one for each personal line to be installed; includes 95B1 power unit).
- D-180758 Kit of Parts (consists of 86A connecting block, D8W-50 cord, jack assembly, plug retainer, and mounting bracket; order one for each primary, basic satellite, or HFAI satellite set to be equipped with a personal

line; do not order for BIS satellite set to be equipped with a personal line).

(b) **External 4A Speakerphone:** Order one of each of the following for each HFAI station to be equipped:

- Adapter, 223C (includes D16H-50 cord and M2FG cord)
- D-180732 Kit of Parts (includes relay board and button stop for SPKR button)
- Loudspeaker, 108A (any color)
- Transmitter, 680A (any color)
- D-180508 Kit of Parts (provides ivory housing for loudspeaker and ivory trim for transmitter)
- Unit, Power, 85B1-49.

(c) **Repertory Dialing:** Order as follows:

- Dial, Repertory, Adjunct, 870A1 (rotary dial) or 2870A1 (TOUCH-TONE dialing) (order one for each desk-type satellite station to be equipped for repertory dialing)
- Cord, D10Y-50 (order one for connecting dial to telephone; 2 feet long)
- Unit, Power, 95B1 (order one for each repertory dial).

(d) **Power Failure Ringing:** Order as follows:

- Unit, Apparatus, 24B (order one for each primary set to be provided with power failure ringing).

(e) **Access to Supplementary Alerting Device:** Order as follows:

- Set, Relay, KS-16626L12 or Relay, KS-16301L17 (order one for use with 25A apparatus unit to operate an auxiliary signal)
- Unit, Apparatus, 25A (order one for each supplementary signaling device to be operated)
- Desired alerting unit and its power source.



(f) **Preset Intercom Voice Signaling:** Order as follows:

- Unit, Apparatus, 26A (order one for each preset intercom voice-signaling arrangement to be installed).

824013270 (P-40J327)—2 feet

824013288 (P-40J328)—4 feet

824013296 (P-40J329)—6 feet

824010995 (P-40J099)—12 feet.

(g) **Paging:** Order as follows:

- Set, Loudspeaker, 109A (order quantity required for paging and background music; includes wall mounting bracket with 85A connecting block attached, D8W cord, and four rubber washers).



*Each 109A loudspeaker consumes as much power as a primary, basic satellite, or BIS set. Refer to paragraph 4.11.*

- Coupler, Voice, 33C (one is required for background music on any paging system; **can be same one used for music-on-hold**)
- Unit, Apparatus, 27A (order one for interface between 4A System and a customer-owned and maintained [COAM] paging system).

**Note:** The 27A will not drive COAM speakers directly.

- Set, Relay, KS-16626L12 (order one for use with COAM paging system that requires a contact closure).

(h) **External Ringing:** Order as follows:

- Ringer, E1CM, S1AMP, or L1AM (order up to three for each CO/PBX line to be equipped with external ringing but no more than two if power failure ringing is provided).

(i) **Supplementary Power:** Order as follows:

- Unit, Power, 19B4 (order one if the power requirements of the system being installed exceed the capacity of the built-in power supplies in the primary sets; refer to paragraph 4.11 for details of calculating power requirements)
- Cord, Power (order one of required length for 19B4 power unit):

824013262 (P-40J326)—1-1/2 feet

### C. Optional Components

**3.04** Order the following components as required to implement options (see Table A).

(a) **Privacy:** Order as follows:

- D-180729 Kit of Parts (privacy circuit board; order one for each station to be locked out).

(b) **Music-on-Hold:** Order as follows:

- Coupler, Voice, 33C (order only one per system when music-on-hold is provided and/or when background music is provided on paging system)
- D-180980 Kit of Parts (music-on-hold circuit board; order one for each primary station and each personal line to be equipped with music-on-hold).

(c) **Tone-on-Hold:** Order as follows:

- D-180731 Kit of Parts (tone-on-hold circuit board; order one for each primary station and each personal line to be equipped).

(d) **Wall Mounting:** Order as follows:

- D-180747 Kit of Parts (order one for each BIS or HFAI set to be converted from desk set to wall set).

(e) **Code Busy Indication:** Order as follows:

- Key, 664C (code busy DSS key; order one for each station to be equipped for busy status indication; includes E-6873 key designation tabs).



*Each 664C key consumes as much power as a primary, basic satellite, or BIS set.*

(f) **Handsets for Special Applications:** Order as follows:

## SECTION 518-450-106

- Handset, G6BM (impaired hearing, modular)
- Handset, D-180413 (more receive gain than G6BM, modular)
- Handset, G7BM (weak speech, modular)
- Handset, G8BM (noisy location, modular)
- Handset, G15AM (general use, modular)
- Handset, G4BM (G-type equipped with shoulder rest, modular)
- Handset, G36AM (long loop, 3-dB transmit gain, modular)
- D-180851 Kit of Parts (ivory transmitter and receiver covers; order one for each handset).

### D. Interconnection Components

**3.05** Unless otherwise noted, the following list consists of typical components recommended for interconnecting the parts of the 4A System.

- (a) Adapter, 3-Way Bridging, KS-19252 type
- (b) Block, Connecting, 91B (**required** for connecting primary set to network interface and system cable)
- (c) Blocks, Connecting, 66-Type in various configurations:
  - Backboard, 184A1 (includes two 66B4-25 blocks)
  - Backboard, 184B2 (includes four 66B4-25 blocks)
  - Block, Connecting, 66E3-25
  - Adapter, 161A (adapts 66-type terminals for spade-tipped leads).
- (d) Cables, Connector (for system cabling between telephone sets; specify desired length):
  - A25B (single-ended)
  - A25B (double-ended)
  - A25D (single-ended)

- B25A (double-ended).

(e) Cable, D Inside Wiring

(f) Cord, D50AB-50 (7 feet or 18 feet; extension mounting cord for satellite sets; **not intended for extending primary set mounting cord**)

(g) Cord, D4BU or D6AP (double-ended, modular)

(h) Wire, Station, D, H, or SK.

### E. Replaceable Components

**3.06 All Sets:** Order as follows:

- Amplifier, 841009103
- Dial, as required per Table C
- Assembly, Loudspeaker, 841009053
- Cord, H4DU-50 (handset cord)
- Form, E-6723 (key designation tabs for line keys and standard DSS keys)
- Form, E-6873 (key designation tabs for code busy DSS keys)
- Handset, K2C-50
- Jack, 616JK (handset jack)
- Key, 663A2 (line key) for use in all sets
- Key, 663A3 (line key) for use in non-HFAI and non-BIS sets
- Key, 664B (DSS key)
- Key, 683C (recall key)
- D-180828 Kit of Parts (963E-2 connectors for use as shorting bars on interconnect field)
- Potentiometer, 842618985 (loudspeaker volume control).

**3.07 Primary Sets:** Order as follows:

- Assembly, Base, and Logic, 841009087 (includes base, control logic board, and wiring harness)

TABLE C

## DIAL ORDERING INFORMATION

| TYPE DIAL                                  | TELEPHONE SET        |             |
|--|----------------------|-------------|
|  | PRIMARY OR SATELLITE | BIS OR HFAI |
| Rotary Dial Without Brackets               | * or †               | ‡           |
| Rotary Dial With Brackets                  | † or §               | §           |
| TOUCH-TONE Telephone Dial Without Brackets | ¶ or ††              | ††          |
| TOUCH-TONE Telephone Dial With Brackets    | ** or ††             | ‡‡          |

\* Order Dial, Rotary 8SA-119

† Order Assembly, Dial, Rotary 841015001

‡ Order Dial, Rotary 8TA-119

§ Order Assembly, Dial, Rotary 841010770

¶ Order Dial, TOUCH-TONE Telephone 35AY3A

\*\* Order Assembly, Dial TOUCH-TONE Telephone 841015019

†† Order Dial, TOUCH-TONE Telephone 35AU3A

‡‡ Order Assembly, Dial, TOUCH-TONE Telephone 841010762

- Assembly, Field, Interconnect, 841009954
- Cord, D50AB-50 (mounting cord, 7-foot only)
- Housing, Upper, 61AU-50
- Housing, Lower, 61BL-50
- Transformer, KS-21361L5 (includes 6-foot power cord and heat sink).

**3.08 Basic Satellite Sets:** Order as follows:

- Assembly, Field, Interconnect, 841009954 (wall sets only)
- Assembly, Field, Interconnect, 841009988 (desk sets only)
- Cord, D50AW-50 (mounting cord, desk sets only)
- Housing, Lower, 61AL-50 (desk sets only)
- Housing, Upper, 61AU-50
- Housing, Wall, 61AY-50 (wall sets only).

**3.09 BIS Satellite Sets:** Order as follows:

- Assembly, Field, Interconnect, 841015449
- Circuit, Interface Signaling, Voice, 841010788
- Cord, D8W-50
- Cord, D50AW-50
- Housing, Lower, 63AL-50
- Housing, Upper, 63AU-50
- Transformer, 2012D
- Transmitter-Receiver, 1A (BIS module).

**3.10 HFAI Satellite Sets:** Order as follows:

- Assembly, Field, Interconnect, 841015050
- Cord, D50AW-50
- Housing, Lower, 63AL-50
- Housing, Upper, 63AU-50

- Module, HFAI, 841010796.

#### 4. INSTALLATION

##### PLANNING

**Caution:** *Remind the customer that after installation has been finished, primary station power cords must remain plugged in or service will be interrupted.*

**4.01** Consult with the customer to determine where the 4A System stations should be installed, optional features desired, the best routes for interconnecting cables, intercom code assignments, paging requirements, and the optimum locations for connecting blocks, apparatus units, adapters, etc.

**Caution:** *If supplementary power from a 19B-type power unit is needed, the "home-run" method of cabling must be used.*

**4.02** Select the most appropriate method of interconnecting the stations of the 4A System (Fig. 7). Use existing cabling from a previous installation, if possible.

**Caution:** *The 91-type connecting block must always be used for connecting a primary set into the 4A System.*

**4.03** Select and order the appropriate apparatus according to the job requirements (see ORDERING GUIDE).

##### ELECTRICAL PROTECTION

**4.04** Under normal conditions, the 4A System will provide satisfactory performance in the presence of surges in the telephone plant caused by lightning. If care is exercised to follow good protection practices as discussed in Sections 518-010-105, 876-100-100, and 876-300-100, there should be no need to install a coupled bonding conductor.

**4.05** ***Coupled Bonding Conductor:*** Under unusual circumstances, a particular installation may experience a high incidence of lightning-related troubles. This might be due to the excessive length of the bonding conductor between the protector and power grounds. Where the length of the bond between these grounds exceeds 20 feet, use of a coupled bonding conductor is recommended.

**4.06** A coupled bonding conductor follows the same route as the inside wiring cable. This conductor can consist of a shield, spare pairs of the inside wiring cable, or a 6-gauge wire tie-wrapped to unshielded cable. It is connected to the lug on the building entrance facility protector and to the equipment single point ground terminal. ***Due to the mutual coupling between this wire and the tip and ring conductors, the potential difference appearing between the equipment ground and the protector lug is minimized.***

**4.07** In an actual 4A System installation, the coupled bonding conductor should be connected between the green wire ground terminal of the 117-volt 60-Hz power outlet serving each primary set, 19B4 power unit, or 30AM apparatus unit and the protector lug (Fig.8). To facilitate connection to the power outlet green wire ground, an outlet adapter such as the Hubbell part 5291 (brown) or 5291-1 (ivory) can be used.

##### ELECTRO-MAGNETIC INTERFERENCE (EMI)

**4.08** The 4A System has been designed with adequate electro-magnetic interference (EMI) protection for most installations. However, a few installations very near radio transmitters may require additional EMI protection for either tip and ring or intercom circuits. For these locations, order 981/2981 or 983/2983-type telephone sets modified per BSRs 361.387.

##### POWER REQUIREMENTS

**Caution:** *Plug primary set and power unit cords into grounded outlets only, in order to meet Underwriter's Laboratory conditions for listing and to provide proper system static electricity discharge protection. Make no connections between any point in the system and building ground, except for the plug-ended 117-volt power cords and the 33-type voice coupler.*

**4.09** The customer is responsible for providing suitable 117-volt 60-Hz power outlets, not under control of switches, for the following apparatus of a 4A System installation: each primary set, 19B-type power unit, BIS station, 4A speakerphone, repertory dial, and 30A-type apparatus unit. The outlets should be separately fused, where possible, to avoid accidental system shutdown.

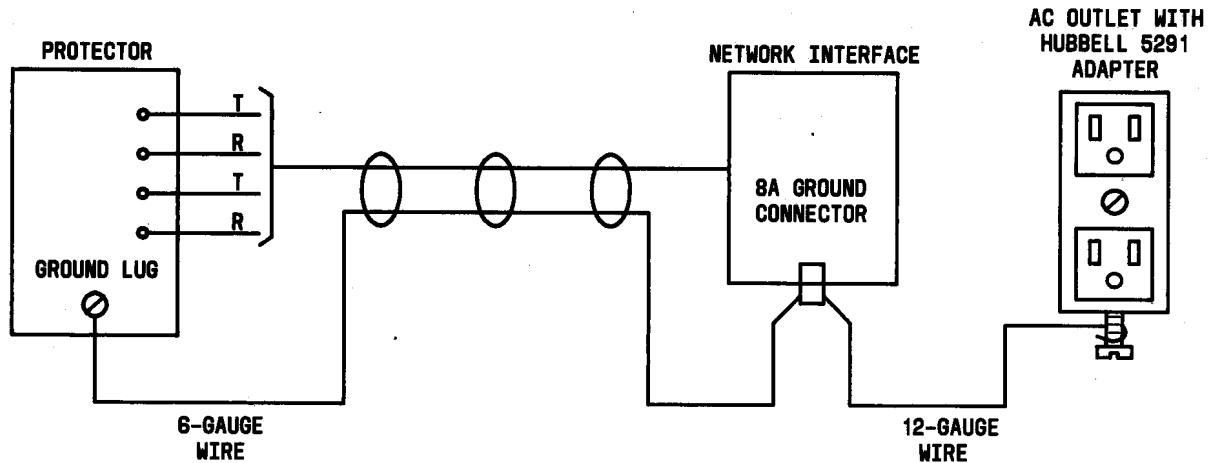

Fig. 8—Typical Arrangement of Coupled Bonding Conductor

#### Supplementary Power

4.10 Sufficient power is available from the built-in power supplies in the primary sets for most 4A System installations. However, a concentration of optional features (HFAI sets, 109A loudspeakers, code busy DSS keys) can make it necessary to install a 19B4 power unit for supplementary power.

4.11 In order to determine whether supplementary power is required, follow this procedure to get the **station equivalent number** of the installation.

- (a) Calculate the values below based on the particular equipment being installed:

(Number of non-HFAI sets, including primary sets)  $\times 1 =$  \_\_\_

(Number of HFAI sets)  $\times 2 =$  \_\_\_

(Number of 664C code busy DSS keys in excess of two per system)  $\times 1 =$  \_\_\_

(Number of 109A loudspeaker)  $\times 1 =$  \_\_\_

Sum (station equivalent numbers) = \_\_\_

- (b) If the system has one primary station and the station equivalent number is greater than 8, install a 19B4 power unit and use the "home-run" method of system connection.

- (c) If the system has two primary stations and the station equivalent number is greater than 16,

install a 19B4 power unit and use the "home-run" method of system connection.

**Example:** Installation has one primary set, four basic satellite sets with code busy DSS keys, two HFAI sets, one BIS set, and one 109A loudspeaker.

- (d)  $6 \times 1 = 6$  (non-HFAI sets)

$2 \times 2 = 4$  (HFAI sets)

$2 \times 1 = 2$  (664C keys)

$1 \times 1 = 1$  (loudspeaker)

Sum = 13.

Therefore, a 19B4 power unit is required.



**Supplementary power cannot extend the system capability (either 1 or 2 primary sets) beyond 16 station sets or 32 station equivalents.**

#### CABLING RESTRICTIONS

**Caution:** No more than 2000 running feet (total) of cable should be used for interconnecting the stations in any installation.

- 4.12 **Station Interconnection:** In installations where bridged cabling is used the maximum

distance between any satellite station and both primary stations or between primary stations must not exceed the restrictions in Table D. In a small system where only one primary station is required and bridged cabling is used, the total number of station equivalents must not exceed eight since supplementary power cannot be used. When two primary sets are used with bridged cabling, the limit is sixteen.

**4.13 Personal Line Cabling:** Personal lines do not utilize the system interconnection cables but require separate connections between stations and 30AM apparatus units. Figure 9 illustrates the limitations on the connection of personal lines. Bridged cabling can connect a maximum of 16 sets to a 30AM apparatus unit.

TABLE D

## LIMITATIONS ON CABLE LENGTH AND SYSTEM SIZE IN BRIDGED SYSTEM

| NUMBER OF STATION EQUIVALENTS | MAXIMUM CABLE FEET FROM SATELLITES TO BOTH PRIMARY STATIONS (NOTE) |
|-------------------------------|--|
| 10 or less                    | 1000   |
| 11                            | 900  |
| 12                            | 800  |
| 13                            | 700  |
| 14                            | 600  |
| 15                            | 500  |
| 16                            | 400  |

**Note:** Sum of cable length from satellite set to first primary set and cable length from satellite set to second primary set. Total number of feet in any installation shall not exceed 2000 feet.

## 5. METHOD OF OPERATION

## ANSWERING CALLS USING HANDSET

**5.01 Incoming Call on CO/PBX Line:** When a tone signal sounds and a CO/PBX line button lamp flashes, answer the call as follows:

- (a) Lift the handset.
- (b) Depress the line button where the lamp is flashing. The tone ringing is silenced and the lamp goes steady.
- (c) Talk with the calling party. [While the call is in progress, the level of incoming voice and tone signaling from the loudspeaker is reduced unless the built-in loudspeaker service is being used (paragraph 5.29).]

**5.02 Intercom Call:** When an intercom voice signal is heard and an intercom path button lamp lights, answer the call as follows:

- (a) Listen for instructions from the calling party.
- (b) If a two-way conversation is to be conducted, lift the handset and depress the proper intercom path button to establish the talking path.

## PLACING CALLS USING HANDSET

**5.03 Outgoing Call on CO/PBX Line** as follows:

- (a) Lift the handset.
- (b) Depress an idle line button (line 1 through 4 or the personal line). The associated lamp lights steady.
- (c) When dial tone is heard, dial the desired number.

**Note:** When making several calls in quick succession, use the RECALL button to get dial tone instead of hanging up the handset after each call.

**5.04 Intercom Call** as follows:

- (a) Lift the handset.
- (b) Depress an idle intercom path button (1 or 2). The associated lamp lights at all stations. (There is no dial tone on intercom.)



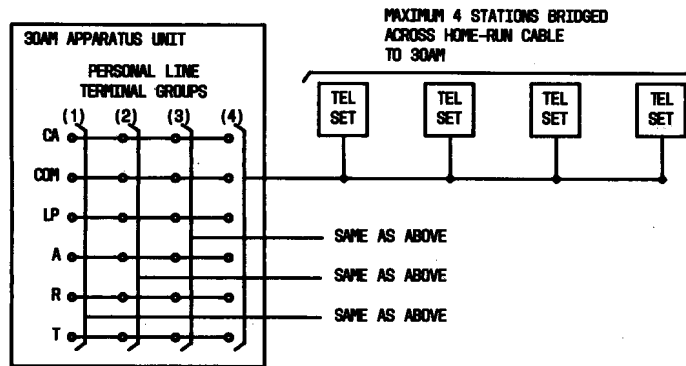

MAXIMUM CABLE LENGTHS

| NO. OF SETS BRIDGED PER TERMINAL GROUP | MAX. CABLE FEET FROM 30AM TO FARTHEST STATION * |
|--|---|
| 1                                      | 1600  |
| 2                                      | 800   |
| 3                                      | 500   |
| 4                                      | 400   |

\* TOTAL CABLE LENGTH FROM 30AM TO ALL STATIONS MUST NOT EXCEED 2000 FEET.

Fig. 9—Personal Line Cabling Limitations



**On outgoing intercom calls from stations equipped with the standard DSS key, the calling party has no way of knowing beforehand if the code being called is busy. At stations having a code busy DSS key, the code of any station which is off-hook or being voice signaled is identified by a steady light in the DSS button.**

- (c) To voice signal the called station, depress and hold the DSS button corresponding to the code of the called station. Transmit the one-way message to the called station. Release the DSS button when the message is completed.
- (d) When the called party answers [as described in paragraph 5.02(b)], a two-way conversation path is established and the DSS button need not be depressed again.

**Note:** Multiple stations can be signaled by operating more than one DSS button at a time or by using the preset multiple voice-signaling option (see paragraph 5.31).

## HOLD OPERATION

**5.05** Any CO/PBX line call can be put on hold while the station is used for another call:

- (a) Tell the distant party that you are going to put the call on hold.
- (b) Depress the HOLD button momentarily. The CO/PBX line button restores to its unoperated position and its lamp changes from steady to wink.

**5.06** To pick up a line on hold, depress the winking line button. The button locks down, the lamp changes from wink to steady, and the connection is established again.

## ANSWERING CALLS USING BUILT-IN SPEAKERPHONE (BIS)

**Note:** On BIS satellite sets, incoming tone ringing and intercom voice signaling are transmitted over the loudspeaker mounted under the handset. Two-way speakerphone conversations

utilize the loudspeaker in the speakerphone module on the right side of the set.

**5.07 Incoming Call on CO/PBX Line:** When a tone signal sounds and a CO/PBX line button lamp flashes, answer the call as follows:

- (a) Depress the line button where the lamp is flashing. The tone ringing is silenced, the lamp goes steady, and the speakerphone turns on automatically. The red speakerphone lamp lights.
- (b) Face the set and carry on the conversation in a normal voice. The volume of the incoming call can be adjusted with the control on the speakerphone module.
- (c) When the conversation is finished, depress the speakerphone OFF button.

**Note:** Whenever the speakerphone OFF button is operated, all depressed CO/PBX line or intercom path buttons will restore.

**5.08 Intercom Call:** When an intercom voice signal is heard and an intercom path button lamp lights, answer the call as follows:

- (a) Listen for instructions from the calling party.
- (b) If a two-way conversation is to be conducted, depress the proper intercom path button to turn on the speakerphone and establish a talking path.
- (c) When the conversation is finished, depress the speakerphone OFF button.

**PLACING CALLS USING BUILT-IN SPEAKERPHONE**

**5.09 Outgoing Call on CO/PBX Line** as follows:

- (a) Depress an idle line button (line 1 through 4 or the personal line). The lamp next to the button lights and dial tone is heard on the speakerphone loudspeaker.
- (b) Dial the desired number.
- (c) When the call is finished, depress the speakerphone OFF button.

**5.10 Intercom Call as follows:**

- (a) Depress an idle intercom path button. The lamp next to the button lights and the speak-

erphone turns on. The red speakerphone lamp lights. No dial tone is heard.

- (b) To voice signal the called station, depress and hold the appropriate DSS button, face the set, and transmit the one-way message via the speakerphone microphone. Speak in a normal voice. Release the DSS button when the message is completed.
- (c) When the called party answers, a two-way conversation path is established. Carry on the conversation using the built-in speakerphone.
- (d) When the call is finished, depress the speakerphone OFF button. Depressed intercom button will restore.

**Built-In Speakerphone Operating Features**

**5.11 Mike Off:** To interrupt transmission to the distant party during a speakerphone call, depress and hold down the MIKE OFF button. Incoming conversation from the distant party is not affected.

**5.12 Transferring From Speakerphone to Handset:** Simply pick up the handset and continue the call in the normal way. The speakerphone turns off automatically.

**5.13 Transferring From Handset to Speakerphone:** Hold down the line button(s) and hang up the handset. The line button(s) remains operated and the speakerphone is turned on. Continue the call using the built-in speakerphone.

**ANSWERING INTERCOM CALLS AT HANDS-FREE ANSWER ON INTERCOM (HFAI) STATION**

**Note:** The HFAI feature is used only for answering intercom calls originated at other stations. To place an intercom call from an HFAI station, use the standard procedure described in paragraph 5.04 or the 4A speakerphone (paragraph 5.21) if one is connected.

**5.14** Incoming intercom calls at an HFAI station turn on the transmitting microphone in the HFAI module so that the calls can be answered without any manual action. The calling party controls the microphone, turning it on when the DSS button is released following a voice announcement, and turn-

ing it off when the DSS button is depressed. The operation of the HFAI feature is as follows:

- (a) An incoming call is preceded by a medium pitch (625-Hz) tone burst over the set's built-in speaker. One of the two green lamps on the HFAI module stays on throughout the call, indicating which intercom path is being used; the red lamp turns on when the caller releases the DSS button, indicating that the microphone is on.
- (b) While the red lamp is on, face the set and answer the call in a normal voice.
- (c) Continue the conversation with the distant party, speaking only when the red lamp is on.
- (d) No action is required at the HFAI station when the call ends. When the caller hangs up, the mike and IC lamps go out and the HFAI module turns off.

#### HFAI OPERATING FEATURES

**5.15 Mike Off:** To interrupt transmission to the distant party during an HFAI call, depress the locking MIKE OFF button on the HFAI module. Incoming conversation from the caller is not affected. To release the MIKE OFF button, depress it again. While the MIKE OFF button is depressed, the microphone is totally disabled and cannot be turned on by the distant party.

**5.16 Do-Not-Disturb:** If reception of incoming intercom calls at the HFAI station is not desired, depress the locking DO NOT DSTRB button. This causes a low pitch (156-Hz) tone to be transmitted to any caller who has called the station by operating a DSS button; it also disables the amplifier in the local set, preventing reception of intercom voice signals. To return to the normal HFAI mode, redepress the DO NOT DSTRB button, unlocking it.

**5.17 Transferring From HFAI Mode to Handset:** Tell the caller that transfer from the HFAI mode to handset is taking place and that operation of the DSS button is no longer required. Depress the proper IC button on the line key, pick up the handset, and continue the call in the normal manner.

#### CALLING AN HFAI STATION

**5.18** Place an intercom call to an HFAI station as follows:

- (a) Lift the handset.
- (b) Depress an idle intercom path button. The associated lamp lights at all stations.
- (c) Depress and hold the DSS button corresponding to the code of the HFAI station.
- (d) If the HFAI station is not busy and not in the "do-not-disturb" mode, a medium pitch tone burst is heard when the DSS button is depressed to voice signal the station. Make the announcement to the HFAI station after the tone. Release the DSS button to hear the HFAI station's response.

**Note:** After the HFAI station has answered, operation of the DSS button to talk again does not result in any more tones.

- (e) If the HFAI station is in the "do-not-disturb" mode, a continuous low pitch tone is heard when the DSS button is depressed. The call cannot be completed. Hang up and call again later.
- (f) If the HFAI station is busy with another call, no return signal is heard. Hang up and call again later.

#### 4A SPEAKERPHONE OPERATION

**5.19** The 4A speakerphone can be installed only with an HFAI station telephone set. It is used to provide optional hands-free operation on CO/PBX line calls or outgoing intercom calls.

**5.20 Incoming Calls:** When a tone signal sounds and a CO/PBX line button lamp flashes, answer the call as follows:

- (a) Depress the line button where the lamp is flashing.
- (b) Operate the ON button of the speakerphone transmitter. The tone ringing will be silenced and the lamp will go steady.
- (c) Talk with the calling party using the transmitter and the loudspeaker.
- (d) When the conversation is over, operate the OFF switch on the speakerphone transmitter.

**Note:** Operation of the speakerphone OFF switch does not cause line buttons to pop up. To

restore line buttons, lift the handset momentarily. Always do this after a conference call.

**5.21 Outgoing Calls** as follows:

- (a) Depress an idle line or intercom button.
- (b) Operate the ON button of the speakerphone transmitter. Dial tone is heard on CO/PBX lines but not on intercom.
- (c) Dial the desired CO/PBX number or voice signal the desired station.
- (d) When the called party answers, use the transmitter and the loudspeaker to carry on the conversation.
- (e) When the conversation is over, operate the OFF button on the speakerphone transmitter. [See Note following paragraph 5.20(d).]

**5.22** When it is not desired to transmit conversation from the surrounding area to the distant station, disable the transmitter by holding down the ON button. Incoming conversation will not be affected.

**5.23** To transfer from speakerphone to handset operation during a conversation, simply lift the handset. Transfer occurs automatically.

**5.24** To transfer from handset to speakerphone operation during a CO/PBX line conversation:

- (a) Put the line on hold.
- (b) Hang up the handset.
- (c) Turn the speakerphone on.
- (d) Depress the CO/PBX line button.

**5.25** To transfer from handset to speakerphone operation during an intercom call:

- (a) Hang up the handset.
- (b) Turn the speakerphone on.
- (c) Depress the IC button.

**MISCELLANEOUS OPERATING TECHNIQUES**

**5.26 Multiline Conferencing:** Two or more CO/PBX lines and any 4A System station can be

conferenced by placing several successive calls on hold and then picking them up together as follows:

- (a) Establish a CO/PBX line connection either by answering an incoming call or completing an outgoing call.
- (b) Put the call on hold by depressing the HOLD button; the line button will restore to its unoperated position and its lamp will wink.
- (c) Establish another CO/PBX line call.
- (d) While holding down the second line button, depress the held line button. The local station and the two CO/PBX lines are then conferenced together.
- (e) Additional CO/PBX lines may be added by repeating (b), (c), and (d).

**Note:** The number of lines which can be conferenced satisfactorily is limited because transmission quality among the lines will be degraded as more lines are added.

- (f) To put all the outside lines on hold simultaneously, depress the HOLD button; to reenter the conference, simultaneously depress the line buttons again.



**Intercom and CO/PBX lines cannot be conferenced together.**

**5.27 Multistation Conferencing:** To add other stations in the system to a CO/PBX line call, follow this procedure:

- (a) Place the CO/PBX line call on hold.
- (b) Using the intercom, call the station or stations wanted in the conference and tell each to pick up the line on hold.
- (c) Return to the held line by picking it up at the local station again. The conference is established when the other stations pick up the held line also.
- (d) If any of the stations to be conferenced has the **privacy** feature, all the stations should hold down their PRIV RLS buttons until everyone has picked up the held line.
- (e) Any station can hang up during the conference without affecting the other parties.

**5.28 Repertory Dialing:** At stations where a repertory dialing adjunct is attached, outside dialing can be done either on the telephone set dial, the dial on the adjunct, or by means of the memory buttons on the adjunct. Refer to Section 501-164-202 for detailed information on the operation of the repertory dialer.

**5.29 Built-In Loudspeaker Service (Stations Without Speakerphone):** To amplify and broadcast to the surrounding area the incoming part of a telephone conversation, depress the SPKR button on the line key. The button locks down until depressed again. Adjust the output to the desired level with the thumbwheel volume control. When the conversation is over, release the SPKR button before replacing the handset so that feedback "squeal" does not occur when the handset is brought near the speaker.



**Incoming voice and tone signaling is not attenuated in the off-hook condition if the SPKR button is locked down. This button is not linked to the ABR mechanism.**

**5.30 Paging:** The paging system is used in the same way as voice signaling on intercom. To make an announcement, go off-hook, select an idle intercom path, depress the DSS button of the paging code. Transmit the message over the handset while holding down the DSS paging button.

**5.31 Preset Multiple Voice Signaling on Intercom:** This feature is used in the same way as voice signaling a single station. Go off-hook, select an idle intercom path, then depress the DSS button corresponding to the preset group of stations to be signaled. Transmit the message over the handset while holding down the DSS code button.

**5.32 Supplementary Signaling:** To operate an auxiliary signal via a 25A apparatus unit, momentarily depress the DSS button assigned to supplementary signaling. Repeat the operation as required.