

COMMON SYSTEMS
CABLE RACK REQUIREMENTS

Contents	Page		
1. GENERAL	1	A. Junctions	10
A. Description And Sizes	2	B. Terminations	11
B. Safe Loads	2	C. Spiral and Vertical Offsets	11
C. Planning	4	3. SUPPORT	12
General	4	4. BRACING	14
Rack Sizing	6	A. General	14
Cable Route Diversity	6	B. Fiber Optic Cable Racks	15
Entrance Cable Rack	7	5. CDO EQUIPMENT BRACING	15
Lineup Cable Racks	7	6. MISCELLANEOUS CABLE SUPPORTS	16
Cross Aisle Cable Racks	8	7. REFERENCES	17
Main Aisle Cable Racks	8	8. PBS D LIST	18
Via Cable Racks	8	9. REASON FOR REISSUE	18
D. Cable Pileup Monitoring	9		
E. Cable Rack Restriction Markings ...	9		
F. At Customer Premises	9		
2. ASSEMBLY	10		

1. GENERAL

1.01 This section provides the guidelines for engineering and installing cable rack arrangements in network equipment environments. The guidelines shall be followed when providing power and switchboard cable racks for a new office and for growth to an existing office by all SBC-LECS. The guidelines shall also be applied when all or a portion of network equipment is to be removed from an office and the cable racking above the removed equipment will remain in place. Refer to material ordering drawing MS006-151 for the cable rack and assembly hardware associated with this section. Refer to part 6 of this section for additional cable rack engineering references.

1.02 This section shall be used in conjunction with BSP 800-006-150MP *Common Systems Network Facility Auxiliary Framing and Bracing Engineering Requirements*, and BSP 800-003-150MP *Central Office Cable And Wire Installation And Removal Requirements Cable Racks and Raceways*.

The following is a list of terms and their meanings as used in this document:

TERM	MEANING
BRACE / BRACING	The diagonal member that is used to prevent swaying or whipping of a cable rack.
CABLE HOLE	An opening in a wall, partition, or floor for passage of cable and wire.
CABLE RACK	The supporting structure for dc power and copper communications cable.
POWER CABLE RACK	Cable rack that is dedicated (restricted) to the routing and support of office and equipment dc power distribution cables only.
SWITCHBOARD CABLE RACK	Cable rack that is used for routing and support of network switching and transmission cables in general. Switchboard cable racks may contain certain types of equipment dc power distribution cables.

A. Description and Sizes

1.03 Cable racks used in network facilities shall be of the steel ladder type construction shown in Fig. 1A. Cable racks shall consist of 2 x 3/8 inch rectangular side rails called “stringers” between which are welded on 9 inch centers 1 x 1/2 inch cross members called “straps”. The first and every other strap of cable racks wider than 24 inches shall be reinforced with a 1 inch by 1/4 inch steel bar.

1.04 Fig. 1A also indicates the standard widths of cable rack used in network facilities. Commercially available cable racks having widths different than those shown in Fig. 1A are acceptable for use when they are appropriate for the cabling needs of a particular equipment or office arrangement. Other than their width, the construction of commercial cable racks used in network facilities for equipment cabling shall agree with 1.04 and Fig. 1A.

1.05 Bar type cable racks shall not be provided for new or growth of existing office cable rack arrangements. Fig. 1B depicts the construction characteristics of bar type cable rack which is no longer approved for use in network facilities because of their fixed uprights (horns) and their seismically inferior construction. Reference to bar type cable racks is included in this section for discussion purposes only because the rack type exists in some network buildings. Fig. 19 depicts T-Section for Bar type over aisle to ladder type cable rack. Fig. 1C depicts joining bar type to ladder type cable rack of the same width. When a new cross aisle rack tees into an existing bar type cable rack, finishing caps shall be installed at the end of all cross straps that project within the T-intersection. The finishing caps shall be secured to the cable rack horns by coating the inside of the caps with an adhesive prior to placing the caps on the horns.

B. Safe Loads

1.06 The permissible pileups of cabling on horizontal cable racks are provided in TABLE A. The purpose of cable pileup restrictions are to ensure the weight of installed cable for an equipment area is evenly distributed across its ultimate support members such as ceiling anchors and/or equipment frameworks, and to facilitate the removal of cable that is no longer in service. Generally, cable pileup shall not exceed the width of the cable rack for cable racks less than 15 inches wide, or as indicated below for cable racks 15 inches and greater in width. The 5 foot and 6 foot spacing of supports refers to the overall supporting scheme of an equipment or cable racking area, not to any one support span along a run of cable rack. Refer to the cable rack planning part of this section.

TABLE A
PERMISSIBLE CABLE PILEUPS

SECURED POWER CABLE			SECURED SWITCHBOARD CABLE		
RACK WIDTH	SUPPORTS ON		RACK WIDTH	SUPPORTS ON	
	5' CENTERS	6' CENTERS		5' CENTERS	6' CENTERS
5"	Width Of Rack	Width Of Rack	5"	5"	5"
1'-0" to 1'-8"	7"	6"	1'-0" to 2'-1"	12"	10"
UNSECURED SWITCHBOARD CABLE					
RACK WIDTH	SUPPORTS ON				
	5' CENTERS	6' CENTERS			
5" to 1'-0"	Width Of Rack	Width Of Rack			
1'-3" to 2'-1"	15"	12"			

1.07 The cable pileup of vertical cable racks passing through building floors shall not exceed 12 inches for switchboard cable racks or 7 inches for power cable racks. To provide the space required to properly close and fire/smoke stop a cable hole, the pile-up on all vertical racks shall be additionally limited so that cable is not closer than 3 inches to the face of the cable hole.

1.08 TABLE B can be used to estimate the weight of cable on a cable rack. The weights for switchboard cable listed in TABLE B are based on TABLE A pileup restrictions and; the assumption there is a cable density of 0.6 pounds per square inch (cross sectional area) of unsecured switchboard cable per linear foot of cable rack, and a density of 0.8 pounds per square inch (cross sectional area) of secured switchboard cable per linear foot of cable rack. These densities include an allowance for secondary power distribution cables which are usually installed on switchboard racks.

TABLE B
APPROXIMATE WEIGHT OF CABLE RACKS AT FULL CAPACITY

Cable Rack Width	Cable Type	Cable Rack Support Spacing			
		5'-0"		6'-0"	
		lbs / Linear Ft	Total Weight	lbs / Linear Ft	Total Weight
1'-0"	Secured	105.6	528	105.6	633.6
	Unsecured	79.2	396	79.2	475
	Power	108	540	86.4	518.4
1'-3"	Secured	134.4	672	112	672
	Unsecured	126	630	100.8	604.8
	Power	135	675	108	648
1'-8"	Secured	182.4	912	152	912
	Unsecured	171	855	136.8	820.8
	Power	189	945	151.2	907.2
2'-1"	Secured	230.4	1152	192	1152
	Unsecured	216	1080	172.8	1036.8

1.09 The weight of power cable varies noticeably with its diameter and no simple average exists for estimating power cable weight according to the cable pileup on a cable rack. The pile-up information for power racks mentioned in 1.07 and in TABLE B are based on all cable being 750 kcm having an overall outside diameter of 1.34 inches, a per linear foot weight of 2.7 pounds, and a maximum pileup of 5 layers of cable (7") for 5'-0" cable rack support spacing schemes and 4 layers for 6'-0" support spacing schemes per the following:

- A 1'-0" cable rack equates to cable layers of 5 high by 8 wide (40 cables total).
- A 1'-3" cable rack equates to cable layers of 5 high by 10 wide (50 cables total).
- A 1'-8" cable rack equates to cable layers of 5 high by 14 wide (70 cables total).

1.10 For the purpose of determining the spacing of cable rack supports for other than normal applications or office conditions, the safe loads for beam clamps, ceiling inserts, threaded rods, etc. may be considered to be as shown in TABLE C.

TABLE C
SAFE LOADS OF EQUIPMENT ENVIRONMENT APPARATUS

APPARATUS	SAFE LOADS (in pounds)
5/8-11 threaded inserts	1200
Ceiling insert (set in place when ceiling is poured)	1200
Acme type beam clamps	800
5/8" drop-in anchors	480
3/8" drop-in anchors	300
3/8" lag screws in wood 2" or more	300
Framing channels (paired 2 x 9/16 x 3/16" steel)	
Span Between Supports	
Up to 2'-0"	2000
2'-0" to 3'-0"	1500
3'-0" to 5'-0"	1000
5'-0" to 7'-0"	700
7'-0" to 8'-0"	500
Embedded ceiling channel (Unistrut) At any one point	2000
Where two or more loads are within 2'--0" of each other	2000 total for the group of loads

C. Planning

General

1.11 The objective of cable rack engineering is two-fold. First is the assurance equipment and office cable rack layouts are configured in a way that cable pileup is distributed across an equipment area so that unnecessary concentrations of cable (congestion) on individual racks are avoided. Secondly, is the assurance that a reasonable capacity for additional equipment cabling is provided initially for subsequent equipment growth jobs, thus minimizing the need to engineer and install additional racking as planned equipment is installed. This is accomplished by engineering cable rack arrangements for the foreseeable needs of the equipment area rather than just the needs of the equipment being added on a particular job, and knowing in advance when additional office cable racking is needed.

1.12 Unlike an equipment area's auxiliary framing grid, the developed overall cable racking plan for an equipment area need not be furnished in its entirety on the initial equipment installation job. This is because equipment space usage (what is installed where) tends to change with changes in equipment technology and the business direction of the equipment office; and the actual location of office cable racks needs to be coordinated with the installed location of equipment frames and their physical cabling characteristics.

1.13 Equipment cable racking should only be furnished and installed for equipment configurations engineering knows or is reasonably certain will be installed in the near future, and to comply with the 75% cable capacity requirement discussed later in this part. This practice minimizes the possible need to reconfigure installed cable rack to suit the actual location and cabling characteristics of future equipment.

1.14 To communicate a developed overall cabling scheme of an equipment area to subsequent cable rack engineers, the overall plan for an equipment area should be depicted on the Auxiliary Framing and Cable Rack Plan office record. Using traditional office record keeping standards future cable rack paths are depicted in solid or dashed thin line work as opposed to existing cable rack paths which are depicted using heavy solid line work. The practice of continuously documenting cable racking schemes in this manner should enable harmonious equipment and cable rack growth and simplified subsequent cable rack engineering effort.

1.15 The following guidelines apply to cable rack engineering in general:

- (a) Power cable racks shall not exceed 1'-8" in width.
- (b) Cable racks shall not be located close to building conditions or equipment that may subject installed cabling to damage or detrimental conditions.
- (c) Except as noted below, cables leaving a cable rack and entering equipment frames shall not be unsupported for a distance greater than 3 feet (measured along the arc of the shortest cable).
 - 1. Cables to conventional office distributing frames (copper cable) may be unsupported for a distance of 4 feet to accommodate the location of the frame's first transverse apparatus support member.
- (d) Vertical runs of power cable rack shall not exceed three floors of continuous in-line length (e.g. basement to 3rd floor). This is to avoid excessive vertical loads on cable rack fabrications and cable securing methods. When a vertical run of power cable rack must exceed three floors, a horizontal section of rack at least 20 cable feet in length shall be introduced into the power cable run at intervals not exceeding three floors (3rd, 6th, etc.). This may be accomplished by using cable holes that are vertically offset from each other by at least 20 cable feet, or by engineering a 20 cable foot horizontal loop in the cable rack run when the same vertical path of cable holes must be used. Vertical cable racks are considered continuous even though their overall length may be interrupted by cable hole sheathing material.
- (e) Unless otherwise directed by equipment documentation, lineup cable racks shall be placed at the front of equipment frames to complement the front mounted rear cabled characteristics of equipment units.
- (f) Office cable racks shall be furnished in manufactured lengths of 9'-8 1/2".
- (g) A clearance of 5 inches should be provided between the side or end of a cable rack and a building column or surface.
- (h) An installer's hand/forearm clearance of 4 inches should be provided between the ultimate cable pileup of a cable rack and any obstruction.
- (i) A minimum of 1'-6" of working space should be provided on at least one side of a cable rack for installation access.
- (j) The method for supporting cables at turns or junctions, in vertical or inverted horizontal cable runs, where the turn of the cable does not provide proper support; a 1/8 inch x 1 inch flat bar shall be placed diagonally across the rack in a manner to provide proper support for the cable. Flat bar shall be secured by simple stitching to the cable rack per figure 17.

Rack Sizing

1.16 Cable rack layouts shall be engineered using cable rack widths that are appropriate for the cable rack's purpose and installed location. A cable rack's purpose is to accommodate equipment cabling over an extended period of time (general purpose racks), or to accommodate a specific amount of cabling to a specific equipment type or location (special purpose racks). Special purpose racks are not intended for general equipment cabling and shall be sized to the narrowest width possible to minimize the consumption of overhead cable rack space in general. The following is how the different standard cable rack widths should be applied for general purpose equipment cable rack layouts:

- ≤1'-0" Small or isolated equipment areas having limited long term cable capacity requirements.
- 1'-3" Cable racking in general where aisle space and installer access is limited.
- 1'-8" Main aisle, cross aisle, via, and dc power cable racks in general; vertical racks for cables passing through building floors; lineup racks for conventional office distributing frames (minimum width) and manual DSX equipment; lineup racks for equipment areas employing the use of wide equipment aisle ways (nominally 4'-0" front and 3'-0" rear).
- 2'-1" As necessary to suit specific equipment or office conditions. These wide racks are usually appropriate for HMDF cabling and where cable pileup space is severely restricted by HVAC ducts and other obstructions.

Cable Route Diversity

1.17 Engineering cable route diversity into an office cable distribution system (cabling scheme or cable rack layout) is a vital component of effectively managing cable lengths, cable pileup, congestion, and the usable life of an installed cable rack arrangement. Cable route diversity is a matter of providing multiple cable rack paths directly above equipment (cross aisle racks) and between equipment areas (via racks), and engineering cable lengths and routes using more than one cable rack path when appropriate (service protection or pileup avoidance).

1.18 To accomplish the above, more than enough cable capacity shall be engineered into network equipment environments initially by the use of multiple cable rack paths. The more cable paths there are, the easier it is to spread cable across an area, the less cable pileup there will be in general and at any one cable rack location, and the easier it will be to access and remove cable no longer in service.

1.19 Cable rack layouts shall be engineered so that no more than 75% of any one cable rack's cable capacity will be consumed by an individual job or project's initial cable installation activity. This is accomplished by the use of multiple via cable rack paths and by the cross aisle cable rack engineering scheme discussed below. Use TABLE D to determine when additional cable rack paths are needed according to the 75% requirement.

TABLE D

CABLE CAPACITY OF STANDARD CABLE RACKS (5'-0" Support Spacing)

Rack Width	Normal Capacity				75% Rule Capacity			
	Capacity (In. ²)		Pileup (inches)		Capacity (In. ²)		Pileup (Inches)	
	Sec.	Unsec.	Sec.	Unsec.	Sec.	Unsec.	Sec.	Unsec.
1'-0"	132	132	12	12	99	99	9	9
1'-3"	168	210	12	15	126	157	9	11
1'-8"	228	285	12	15	171	213	9	11
2'-1"	288	360	12	15	216	270	9	11

Note (1) In.² capacity is based on the rack width minus 1" for stringer attachment hardware.

Note (2) According to the above a new switch or other equipment entity having 500 In.² of **secured** interconnecting cable to other network elements requires a minimum of three 1'-8" via cable rack paths (500/171 = 2.9 racks @ 75% capacity).

Entrance Cable Racks

1.20 Entrance cable racks are used to route outside plant (OSP) cable from the cable entrance facility (CEF) to terminating equipment such as office distribution frames. Unless otherwise documented, OSP cable shall not be placed on cable racks with other office cabling. It is expected that OSP cable will be installed for the life of an office whereas other network cables are subject to cable removal and mining activity as equipment is relocated and replaced during the life of an office. Physically separating OSP cable from other network cabling minimizes the possibility of damage to OSP cables during the installation removal management of other equipment cabling.

1.21 Entrance cable rack for equipment frames installed along cable entrance facility building walls shall be installed at the rear of the equipment lineup. Entrance racks to equipment frames located interior to an equipment area shall be located at the highest level practical in an office to minimize any up-and-over cable rack arrangements and people activity.

Lineup Cable Racks

1.22 Lineup cable racks are used to route cabling between equipment frames within the same equipment lineup. Lineup racks may be located above equipment frames (over-frame) or above the aisle way at the front or rear of equipment frames (over-aisle). Some equipment requires more than one type of lineup rack because different types of cable are used to interconnect the equipment to other network elements. Lineup racks used for different cable types should be arranged in multilevel fashion one above the other (likewise for any associated cross aisle racks).

1.23 Multilevel cable rack arrangements should be engineered so the greater or heaviest amount of cabling is installed at the lowest cable rack level to minimize cable installation and removal effort. For most equipment areas the lowest level of cable rack is used for copper based cables (twisted pair, coax and ABAM/PBAS). The upper level(s) of rack would be used for fiber optic and special purpose cable racks.

1.24 It should be noted there is an increasing use of fiber optic cable to interconnect network elements. Accordingly, for some equipment types or areas the greater or heaviest amount of cabling to be accommodated may be that of fiber optic cables with copper cables being used only for miscellaneous interconnections such as alarms, secondary power distribution, intercom equipment, etc. Under this scenario fiber optic cable racks or raceways could (probably should) be engineered as the lowest level of cable rack for the fiber equipment area, and transitional cable racks engineered for changing the copper cable to a higher level as it enters the area.

Cross Aisle Cable Racks

1.25 Cross aisle racks are short lengths of cable rack placed directly above and at a right angle to equipment lineup racks and are used to provide as direct a cable route as possible between equipment frames in different equipment lineups. As shown in Fig. 2A, cross aisle racks intersect lineup racks and are not continuous runs of cable rack except where they cross a future equipment lineup whose lineup cable rack has not been installed. Cross aisle cable racks shall be located along equipment lineups with approximately 5 feet of space between racks. This spreads cable pileup along the length of equipment lineups avoiding extreme cable pileups on lineup racks.

1.26 The above cross aisle cabling scheme shall be applied to all levels of lineup cable rack engineered into an equipment area except where it is known the inter-lineup cabling of equipment by the upper level racks (lesser overall amount of cabling) will be minimal. Under these circumstances the space between cross aisle cable racks may be increased, or narrow racks can be used to minimize cable rack congestion in the overhead environment.

Main Aisle Cable Racks

1.27 Main Aisle cable racks are used to route inter-lineup cabling between equipment areas separated by a main cross aisle, as the primary entrance point of an equipment area for via cable racks (power being the prime example), and to supplement cross aisle cable pileup management. Main aisle cable racks shall be provided only where needed to minimize obstructing installer access to the overhead environment. Power cable racks should be provided at main cross aisles as an upper level rack because their cable pileup and rework activity is limited compared to that of other types of cable rack.

Via Cable Racks

1.28 Via racks are used to route relatively large amounts of cabling from one equipment location to another without contributing to the cable pileup of an intermediate equipment area's cable distribution system or scheme. Via racks are usually located at a higher level than equipment lineup and cross aisle cable racking and run parallel and/or at a right angle to equipment lineups. Power cable racks are one example of a via cable rack. Via racks are also used with DMS switching equipment to route system cabling in the cross aisle direction because the equipment does not employ the use of its cross aisle cable troughs in SBC LEC equipment environments.

1.29 Via cable racks are generally provided as needed per office or equipment area. When via cable racks are used to route cables between the office HMDF and a remotely located switch, the via racks shall be arranged in cross aisle cable rack fashion along the HMDF lineup cable rack regardless of initial cable pileup calculations (refer to Fig. 2B).

D. Cable Pileup Monitoring

1.30 Cable pileup in office cable racks needs to be continuously monitored so it is known in advance when office cable racks are reaching their ultimate cable capacity, and additional cable racks and/or cable mining is required. An alternate cable management plan (additional cable rack or cable removal effort) should be developed once installed cable racks reach 80% of their ultimate cable capacity (approximately 10 vertical inches). Accordingly, cable rack layouts shall include a cable rack identification scheme that uniquely identifies each run of cable rack in the office. The cable rack identification scheme shall be used to communicate cable routing information to cable installers and to communicate cable pileup information to office planners and cable rack engineers.

1.31 The preferred method of uniquely identifying office cable racks is the **coordinate path** system depicted in Fig. 2B. This method assigns unique alpha and numeric characters to each planned and existing run of office cable rack. The alpha/numeric indicators are also parenthetically qualified to distinguish special purpose or cable restriction information as shown in Fig. 2B for the power cable racks. An acceptable but more cumbersome method of uniquely identifying cable rack paths is the **cross sectional** method illustrated in Fig. 2A. This method is very labor intensive to institute and maintain on office records and is mentioned only because the system may still be used on some existing office records. Only the coordinate path method should be used with mechanized office records.

E. Cable Rack Restrictive Markings

1.32 All special purpose cable racks shall be uniquely identified to indicate the type(s) of cable they are restricted to. The restrictive information shall be in the form of labels or stampings of 3/4" black block characters conspicuously spaced no more than 10 feet apart on both cable rack stringers. In the case of cable racks used for the routing of fiber optic cables, it is acceptable for the cable racks to have a yellow painted finish, or to use self adhesive labels having black characters printed on a yellow background to distinguish them from other office cable racks. Cable restriction information shall also be reflected on the office record cable rack plan drawing.

F. At Customer Premises

1.33 The engineering of equipment and cable rack for a customer's premises application will be done under one of two general scenarios. The first being that where the equipment environment is managed by the customer and SBC LEC is only one of several service providers having equipment in the environment. The second scenario is where the equipment environment is essentially established solely for the purpose of accommodating SBC LEC's network equipment. In this scenario equipment engineering, and subsequently the equipment environment, is managed by SBC LEC. The equipment of other service providers, if any, would be provided for by a separate equipment area managed by the customer.

1.34 The engineering and installation of cable racks at customer premises locations shall be in accordance with the customer's guidelines and requirements for those equipment environments managed by the customer. In the absence of customer documented guidelines, the subject of cable rack engineering shall be negotiated with the customer and documented using this section as reference when possible. The negotiated customer requirements, with regard to cable rack ownership, seismic protection, cable rack construction, support methods, and other matters that directly impact the process of cable rack engineering and installation of current and future jobs, shall be documented on the SBC LEC cable rack plan office record created for the equipment area.

1.35 To the extent physically possible, engineering and installation of cable racks for SBC LEC equipment environments located on a customer's premises shall be in accordance with this section. All engineering restrictions or deviations from this section that are necessary because of customer relations or building design shall be documented on the SBC LEC cable rack plan office record drawing for purposes stated above.

2. ASSEMBLY

2.01 Unless otherwise indicated, cable rack fabrications shall be assembled using the clamping details shown in Fig. 3A through 5A. Where cable rack straps interfere with the proper placing of the clamping details, the cable rack shall be cut back to such a point that the straps will not interfere with the clamping details. Corner clamps may be assembled in positions opposite those shown where necessary to avoid interference with cable rack stringers and straps.

2.02 Except as indicated in 2.08 and Fig. 6F, vertical changes in cable route direction shall be provided for via 45 degree inclines or preformed cable rack turns to avoid sharp bends in cable. Abrupt 90 degree vertical turns in cable rack runs should be used only when absolutely necessary.

A. Junctions

2.03 In general, the longest lengths and the fewest parts practicable shall be used in the assembly of cable rack arrangements. The joining of sections of cable rack for the usual conditions encountered in equipment environments are shown in Fig. 4A through 8B.

2.04 The method of in-line junctioning or splicing two sections of cable rack together is shown in Fig. 5A. No more than one in-line junction shall be used between any two points of support for horizontal runs of cable rack. An in-line junction shall not be used beyond the last point of support of cantilevered racks.

2.05 Cross aisle racks shall be installed at a higher level than lineup racks as shown in Fig. 6B to provide clearance for ac power conduits, runs of secondary auxiliary framing or other apparatus. Cross aisle cable racks may be installed at the same level as lineup racks as shown in Fig. 6A when the associated apparatus space provided for by Fig. 6B arrangements is provided for by some other engineering consideration(s) or office arrangements. All cross aisle cable racks for a given equipment area shall be engineered and installed in a common manner.

2.06 Continuous runs of cross aisle racks are only permitted where ceiling heights or other overhead clearances are favorable to the additional cable pile-up this arrangement causes at cable rack intersections. The Fig. 6B J bolt fastenings shall be installed at all intersections of cross aisle to lineup cable rack.

2.07 Fig. 6CA or Fig. 6CB corner brackets shall be used at cable rack junctions where the radii of the cables is so large that additional cable support is required, or where cables need to be spread out to avoid excessive pile-up.

2.08 Fig. 6J or 6K shall be used when it is necessary to transfer large cables ($\geq 3/4$ " dia.) from the horizontal to vertical plane above cable holes when the horizontal rack is at a right angle and in close proximity to the location of the cable hole. Fig. 6L can be used in place of Fig. 6J and 6K for small diameter cable and when dictated by existing cable rack configurations.

2.09 Use Fig. 6M whenever possible to transition cables vertically between cable racks that are more than 3 cable feet apart and are of a different construction, or are part of different ground planes. The Fig. 6M support rods may be omitted when the preformed cable rack turn is supported by direct attachment to auxiliary framing as shown in Fig. 10A or Fig. 10C. Fig. 6K can be used in place of Fig. 6M for this type of cable transfer when the upper and lower cable racks are horizontally less than 1'-4" apart provided the vertical section of cable rack is 3 feet or less in length and:

- Is independently supported similar to Fig. 6M or
- Is equipped with $\pm 45^\circ$ 5/8-11 threaded rod or flat bar bracing on both sides of the cable rack and
- The $\pm 45^\circ$ bracing is bolted to the horizontal portion of the cable rack transition.

2.10 In-line transitions of cable from the horizontal to vertical plane shall be via Fig. 7A to 7C large cable radius fabrications whenever possible. Transitions of switchboard cable racks should be per Fig. 7A and 7B, however, the use of Fig. 7C is acceptable. Transitions of power cable racks shall be per Fig. 7B and 7C. The intermediate cross straps of the short section of rack shown in Fig. 7B shall be removed from power cable racks if the uninterrupted cable rise exceeds two floors. This is to minimize the possibility of cable insulation damage due to the weight of sagging power cables.

2.11 Clamps used to hold short sections of cable rack in place as shown in Fig. 7A, 7B and 8B to obtain a cable rack offset, or large cable turning radius shall not be subjected to any load other than the cabling at the turn or offset. Refer to 3.04

B. Terminations

2.12 The ends of cable rack shall be terminated as shown in Fig. 9A through 9F. Fig. 9A caps shall also be used on the ends of all cable rack attachment bars (refer to Fig. 6F as an example). Terminating vertical cable rack for cable passage through an angle type sheathing cable hole is shown in figure 9F.

2.13 Fig. 9B closing bars shall be used at non-attached offsets, junctions, and cable rack ends where cables continue to equipment or another cable rack.

2.14 The cable rack feet shown in Fig. 9C may be turned outward at the floor if space permits and the end of the cable rack is enclosed or a trip hazard is otherwise avoided.

C. Spiral and Vertical Offsets

2.15 Spirals are used to form sweeping 90 and 180 degree turns in right angle cable racks which are vertically offset. These turns consist of rod stringers bent on suitable radii and channel cross straps which are clamped to the rods with split eyebolts. Spiral cable rack assemblies shall be engineered and installed in accordance with AT&T standard drawings ED90843-10 and H253-506.

2.16 Fig. 5C, 5E or 5F shall be used when horizontal offsets in vertical cable rack runs are required. Where cable rack appearance is a major factor and suitable enclosures are not possible, offsets in vertical cable racks shall be in accordance with **Bellcore** publication BSP 800-614-157 Fig. 52.

3. SUPPORT

- 3.01 Cable racks shall be supported by direct attachment to auxiliary framing as shown in Fig. 10A unless office conditions require otherwise. External tooth type lock washers shall be used under the nut of cable rack support bolts and threaded fasteners. Cable racks shall not be supported by their cross straps. Auxiliary framing used for the support of cable racks must be supported from ceiling inserts or other auxiliary framing. Self-drilling anchors shall not be used for the attachment of cable rack support apparatus unless their design and installation has been explicitly engineered for the cable loads and building construction they will be used with.
- 3.02 5/8-inch threaded rods shall be used when it is necessary to suspend cable racks from their overhead support members. The distance from the bottom of the supporting auxiliary framing or other structure and the bottom of the suspended cable rack stringer shall not exceed 4 feet-10 inches.
- 3.03 Horizontal cable racks should be supported on approximately 5 foot centers and in no case shall the spacing of supports exceed 6 feet.
- 3.04 Cable rack assembly hardware shall not be relied upon to carry any appreciable load. Except as noted below and covered in 3.05, a cable rack support shall be provided within 2 feet 6 inches of a free-end of cable rack. For the purposes of this requirement, turns, offsets, and intersections having the equivalent of free-ended cable racks are illustrated in Fig. 4A, 4B, 4E, 4F, 5B to 5G, 5H, 6D, 6E, 6G, 7A, 7B, 8A, 8B, 9A, and 9B. Fig. 6M and Fig. 7C are considered to be a free-ended cable rack arrangements if they contain a straight horizontal section of rack ≥ 1 foot in length.
- (a) A support is required for each cable rack shown in Fig. 5B to 5H, 6D, 6E and 8B.
 - (b) The support for Fig. 6M and 7C applications shall be placed on the horizontal section of cable rack.
 - (c) The support for Fig. 8A applications may be provided for either run of cable rack.
- 3.05 Where a free-ended cable rack is joined with corner clamps at a right angle to a rigidly supported cable rack as shown in Fig. 6A and 6CA, the support for the free-ended cable rack may be located up to 5 feet from the intersection provided a cable rack splice (Fig. 5A) is not used within that 5 foot distance (refer to 2.04).
- 3.06 Cross-aisle cable racks which are attached to lineup cable racks per Fig. 6B are considered adequately supported if the cross aisle rack is 6 feet or less in length. Cross aisle racks longer than 6 feet require support by additional auxiliary framing being placed below the rack, or by hanger rods attached to higher level auxiliary framing.
- 3.07 "Studded up" cable racks are not allowed in high seismic risk areas except as covered in 3.10, or where ceiling heights or overhead obstructions do not allow the installation of higher level auxiliary framing. In those cases where a cable rack must be studded up, the threaded rod supports shall be equipped with pipe sleeves and washers (Fig. 10C), threaded rod tie bars (Fig. 11A and 11C), and the rack shall be braced downward to lower level auxiliary framing in both side and endwise directions using the same practices given in part 4 for suspended cable racks.
- 3.08 Where auxiliary framing is associated with the support of duct type frames, and the cable rack is located 1/2" from the frame upright, the cable rack shall be fastened as shown in Fig. 10B.

- 3.09 Small vertical offsets in horizontal runs of cable rack may be used to bridge building or other apparatus as shown in Fig. 8A. The offset cable rack shall be braced in accordance with part 4 if two Fig. 8A offsets are used and the horizontal distance between the offsets is more than 4 feet. Where cable racks such as cross aisle racks are supported approximately 2 inches above auxiliary framing to clear conduit or other apparatus, they shall be supported as shown in Fig. 10C.
- 3.10 Supporting cable racks from building walls shall be avoided whenever possible. Where vertical cable racks must be fastened to building walls or columns to facilitate cabling to wall mounted cabinets or between building floors they shall be supported as shown in Fig. 10D. Each section of vertical rack shall have a minimum of two supports (per Fig. 10D) with a maximum spacing of the supports not to exceed 5 feet. Fig. 10D support arrangement is not intended for heavily loaded cable runs. Vertical racks fastened to building walls or columns which could ultimately support a large amount of cabling shall be terminated at the floor as shown in Fig. 9C. Refer to BSP 800-000-101MP for anchor type.
- 3.11 Vertical cable racks that are attached to building walls or columns shall not be physically connected to a horizontal run of cable rack or to the office superstructure in high seismic risk areas. This is to minimize possible stress to cable rack supports should there be asynchronous movement of the building wall and office superstructure during seismic activity. A minimum distance of 6 inches shall be provided between the end of a horizontal cable rack and a continuing (cable wise) run of vertical cable rack that is attached to a building wall or column.
- 3.12 Where it is necessary to provide for small amounts of cable run horizontally along a building wall, and facilities for an auxiliary framing grid are not available, the cable rack may be supported to the building wall as shown in Fig. 10E. Spacing of supports shall not exceed 5 feet. For larger size cable racks or where cable load exceeds 2 inch pile up, see paragraphs 3.14 through 3.18 for alternate cable rack support.
- 3.13 Cable racks placed on floors require fastening to restrain their possible movement during seismic activity. For safety reasons the fastening should be placed on the inside of the cable rack stringers as shown in Fig. 10F. Cable rack runs 2 feet and longer require two sets of restraints. Locating the restraints at each end of the cable rack as shown in Fig. 10F will require fewer restraints and will assist in the alignment of long runs of rack.

B. Wall Supported Cable Racks

- 3.14 Cable racks located along equipment room wall and where overhead auxiliary framing is not available shall be supported by wall support brackets. Wall support brackets shall only be secured to load bearing walls such as concrete walls, hollow block walls, brick walls or other structural materials. Installation of wall support brackets to partitioning walls may not provide adequate support for cable racks and therefore not recommended.
- 3.15 Wall support brackets as shown in Fig. 10G shall be installed to wall with ½ inch diameter anchors. Wall anchor type shall be appropriate for wall material per Table E. Secure each wall support bracket to wall using three anchors. Cable rack shall be supported by a wall support bracket at least every 5 feet along rack span.
- 3.16 Cable rack shall be secured to wall support bracket with two ¼ inch J-Bolts as shown in Fig. 10G.
- 3.17 Largest cable rack that may be supported by wall brackets shall not exceed 12-inch width. Install appropriate width wall support bracket for the cable rack as shown in Fig. 10G.

3.18 Cable pileup shall not exceed 8 inches on wall supported cable racks carrying switchboard cable. Cable pileup shall not exceed 5 inches for wall supported cable racks carrying primary power cables.

**Table E
Wall Anchor Types**

Wall Material	Anchor Type	Hilti P/N	Anchor Bolt Req.d
Reinforced Concrete	Hilti HDI 1/2	00045754	1/2-13 x 1in.HHCS
Hollow Block	Toggle Bolt 1/2	00066366	Included w/anchor
Hollow Block	Adhesive HIT-HY20	00256479 Adhesive 00088979 1/2 Rod 00020951 1/2 Screen	Included w/anchor
Reinforced Brick	Hilti HDI 1/2	00045754	1/2-13 x 1in.HHCS
Plaster	1/2"x6" Wood Lagbolt		

3.19 In high seismic risk locations, wall mounted cable rack shall not be physically connected to auxiliary frame supported cable rack to avoid pulling wall brackets from wall. Provide minimum distance of 6 inches between wall mounted cable rack and frame supported cable rack.

4. BRACING

A. General

The following bracing figures general apply to regions of high seismic activity, and can be applied in low seismic areas when hung cable rack requires lateral support to reduce movement.

4.01 Except as indicated in part 4(B), cable racks not attached directly to auxiliary framing shall be hung and braced from auxiliary framing as shown in Fig. 11A through 11F to prevent swaying or whipping in both sidewise and endwise directions.

4.02 Cable rack runs which are supported only by hanger rods require a side brace at each support. The braces shall be staggered so they slope in opposite directions at alternate supports along the run of rack (Refer to figure 18). A 5/8-11 nut shall be installed on the hanger rod opposite the cable rack brace when building or other obstructions require side braces to be installed only on one side of cable racks.

(a) Intermediate hanger rod supports of cross aisle racks (see 3.06) comprised of a single piece or section of cable rack do not require side braces because the bracing function is provided by the lineup cable rack fastenings. Side braces shall be provided for all suspended cross aisle cable racks incorporating the use of Fig. 5A in-line junctions.

(b) Hanger rod supported cross aisle racks at the ends of lineups which are fastened to lineup racks on one side only require side braces on the outside stringer only.

4.03 Except as noted below, end braces per Fig. 11D to 11F are required for each run of hanger rod supported cable rack. End braces shall be provided at each end and on approximately 20-foot intervals along the length of suspended cable racks. End braces shall be slanted at opposite directions and should be installed on the same stringer. End braces may be installed on opposite stringers only to avoid obstructions.

(a) End braces are not required for those hanger rod supported cable racks that are at some point attached to auxiliary framing, another cable rack, or an equipment frame that is supported and braced to prevent movement of the cable rack (refer to Fig. 2C).

4.04 In low seismic locations, 5/8" threaded rod may be used for diagonal support of cable racks in place of angle braces where applicable. In general, braces should be provided in low seismic risk locations to prevent lateral movement of cable rack with load equal to medium built person pulling and pushing on empty rack.

B. Fiber Optic Cable Racks

4.05 Cable racks less than 8 inches in width used only for the routing and support of fiber optic cables require side and endwise bracing only if they are suspended more than 18" below auxiliary framing (bottom of framing to top of cable rack) in a high seismic area. 5/8-11 threaded rods shall be used in place of flat bar or angle braces for bracing this type of cable rack arrangement.

(a) Part 4(A) bracing requirements apply to cable racks wider than 8 inches used for fiber optic cables because their cable carrying capacity and resulting overall weight can be much more than the narrower racks described above.

5. CDO EQUIPMENT BRACING

5.01 This part covers cable rack arrangements used in Community Dial Office (CDO) type installations which do not have ceilings suitable for the support of auxiliary framing and high seismic bracing as covered in BSP 800-006-150MP. Traditionally these offices used cable racks (without auxiliary framing) to provide top support of equipment frames. In this type of environment lineup cable racks are supported by direct attachment to equipment frames. For cable rack installed at 9'-0" level and equipment frame at 7'-0" height, a floor stanchion cable support system as covered in BSP 800-006-152MP may be applied. The floor stanchion system provides support for cable racks independent of equipment frames.

5.02 **Prior to 4/1/88** bracing of equipment frames in CDOs was achieved by installing cross aisle cable racks at the same level as the lineup cable racks, and bracing lineup cable racks to building walls that parallel the equipment lines. 1-1/2 x 1-1/2 x 3/16" angles were used to brace lineup cable racks to building walls, and to brace between lineup cable racks where cross aisle cable racks were not installed. **On 4/1/88** the following practices were adopted to enhance the seismic protection of equipment installations in CDO type offices.

(a) In order to spread horizontal forces over a larger area, sections of 5 inch cable rack or extensions of existing cross aisle cable racks shall be used for bracing equipment to building walls, and for bracing between equipment lineups as shown in Fig. 12A and Fig. 12B. It is not necessary to replace angle braces already installed, however, cable racks shall be provided as bracing instead of relocating any existing angle braces.

(b) Equipment bracing shall be continuous between walls that parallel equipment lineups including areas above power equipment. Office cross aisle cable racks serve as equipment bracing and should likewise be continuous between walls that parallel equipment lineups.

(c) Locate wall braces so there is an approximate spacing of 3 feet between braces at the office distributing frame, and a 5 to 6 foot space between braces at other equipment lines. The distance from the end of the end frame in an equipment line and a brace or cross aisle cable rack fastening should not exceed 1'-0".

ISS B, SECTION BSP 800-006-151MP

- (d) Where cable racks with 2-inch stringers are attached to lineup racks having 1-1/2-inch stringers, a section of MS006-150 Det. 22 finish cap shall be taped in place to protect from coming in contact with possible sharp edges of cut cable racks ends.
- (e) A vertical support such as a pipe stanchion is required for cable rack lengths exceeding 6'-0" or an equipment frame may be left in place as a support for the cable rack. Empty equipment frames shall be fitted with a 5-inch tall blank plate between upright located midway up on uprights. The blank plate is required to prevent outward bowing of uprights with large vertical loads on frame. Pipe stanchions or frame supported should be located in future equipment locations whenever possible.
- (f) Cable rack splices in CDO buildings shall be of the through-bolt type shown in Fig. 13 to minimize the possible separation of cable rack sections during seismic activity.

5.03 Auxiliary framing should be used above equipment frames in new CDO buildings and in growth areas of existing buildings to provide greater flexibility in locating equipment frames and office cable racks. In such installations, standard spacing and support guidelines for cable racks and auxiliary framing are applied except that auxiliary framing is fastened to building walls per BSP 800-006-150MP Fig. 24.

5.04 Cable rack support arrangements illustrated in Fig. 14A through 16 should be provided in CDO offices and equipment areas where auxiliary framing is not used and cable racks are supported by direct attachment to the top cross member of equipment frames. Two cable rack supports are required for each isolated equipment frame.

6. MISCELLANEOUS CABLE SUPPORTS

6.01 Studded up cable supports as shown in Fig. 20 may be used to facilitate the addition of small amounts of cable where it is not practical to add cable rack. Studded up supports shall be located approximately every 12 inches along cable racks and auxiliary framing channels. The 12-inch distance shall be reduced if necessary to prevent cables from sagging more than a distance equal to the diameter of the cable or bundles of cable installed on the brackets.

6.02 The miscellaneous cable support brackets shown in Fig. 21 and 21A to 21C should be used for supporting miscellaneous runs of cable where a physical separation from other office cabling is required and the addition of cable rack is not appropriate. Unless otherwise directed by the supporting requirements for a specific cable type, support brackets shall be located on approximate 12-inch centers along their supporting structures. The 12-inch distance between supports shall be reduced if necessary to prevent cables from sagging more than a distance equal to the diameter of the cable or bundle of cable installed on the brackets.

7. REFERENCES

7.01 The figures contained in this section and their related paragraphs are listed below for quick reference.

Figure	Paragraph	Figure	Paragraph
1A	1.03,1.04	8A	2.03, 3.04, 3.09
1B, 1C	1.05	8B	2.03, 2.11, 3.04
2A	1.25, 1.31	9A	2.12, 3.04
2B	1.29,1.31	9B	2.12, 2.13, 3.04
2C	4.03(a)	9C	2.12, 2.14, 3.10
3A to 3D	2.01	9D,E, F, G	2.12
4A,B,E,F,G,H,J,I	2.01, 2.03, 3.04	10A	2.09, 3.01
4C,D	2.01, 2.03	10B	3.08
5A	2.01, 2.03, 2.04, 3.04, 4.02(a)	10C	2.09, 3.07, 3.09
5B,D,G, H	2.03, 3.04	10D	3.10
5C,E,F	2.03, 2.16, 3.04	10E	3.12
6A	2.03, 2.05, 3.05	10F	3.13
6B	2.03, 2.05, 2.06, 3.06	10G	3.15, 3.16, 3.17
6CA	2.03, 2.07, 3.05	11A,C	4.01
6CB	2.03, 2.07	11B	3.07, 4.01,
6D,E	2.03, 3.04	11D,E,F	4.01, 4.03
6F	2.02, 2.03, 2.12	12A,B	5.02(a)
6G	2.03, 3.04	13	5.02(f)
6H	2.03	14A,B	5.04
6J,L	2.03, 2.08	15, 16	5.04
6K	2.03, 2.08, 2.09	17	1.15
6M	2.03, 2.09, 3.04	18	4.02
7A, 7B	2.03, 2.10, 2.11, 3.04	19	1.05
7C	2.03, 2.10, 3.04		

<u>TABLE</u>	<u>DESCRIPTION</u>	<u>PAGE</u>
A	PERMISSIBLE CABLE PILEUPS	2
B	APPROXIMATE WEIGHT OF CABLE RACK AT FULL CAPACITY	3
C	SAFE LOAD OF EQUIPMENT ENVIRONMENT APPARATUS	4
D	CABLE CAPACITY OF STANDARD CABLE RACKS	7
E	WALL ANCHOR TYPES	14

For fire and smoke stopping of a cable rack opening refer to BSP-800-005-200MP

For space required to properly close a cable hole refer to PARAGRAPH 1.07

8. PBSB LIST

8.01 The following is a list of other cable rack/raceway engineering guidelines that are applicable for the subjects or applications indicated:

PBSD-ED-6303	Method Of Cabling Fiber Distribution Frames In Raised Floor Environments
PBSD-ED-6601	Guidelines For Engineering OFNR Entrance Cable Racks
PBSD-ED-6602	Miscellaneous Apparatus For OFNR And Other Fiber Cable Racks
PBSD-ED-6606	Collocation Overhead Superstructure Engineering

9. REASON FOR REISSUE

9.01 This section was reissued to change its title and make the below changes.

1.01 add reference to MS006-151

3.07 changed 11B reference to 11A and 11C

3.19 renumbered from 3.18

4.04 deleted and renumbered 4.05 and 4.06 accordingly

5.04 renumbered from 5.03

Add Part 6

Fig. 11A increased vertical distance of application

Fig. 11B destandardized use

Fig. 11D increased vertical distance of application

Fig. 11E destandardized use

Add Figures 20 and 21

Delete lock washer references in Figures throughout the document.

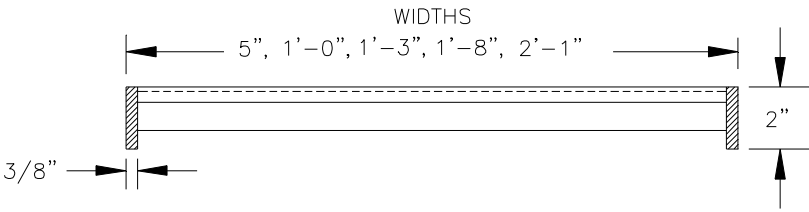
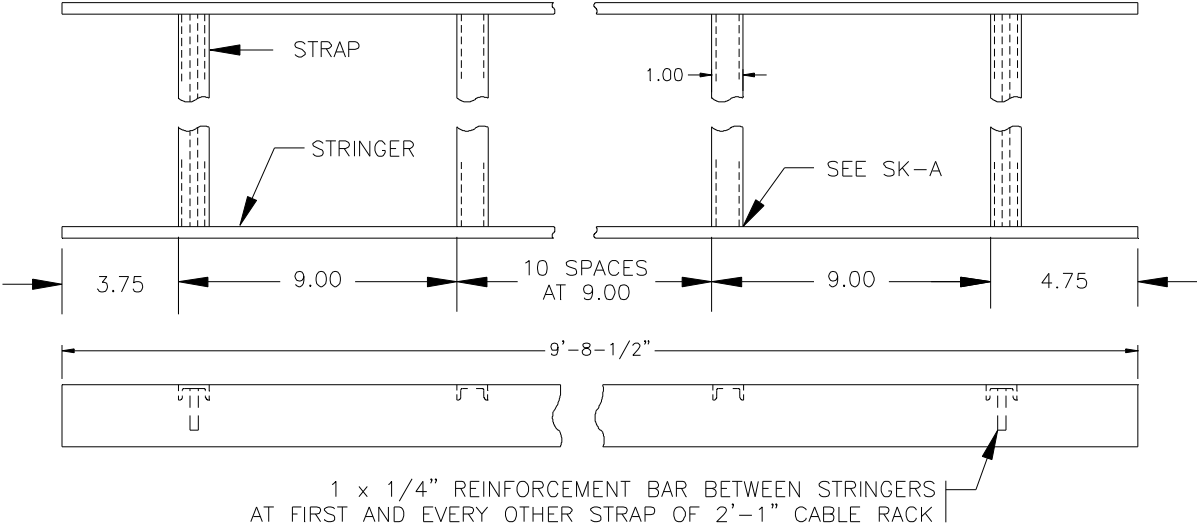

Typical Ladder Type Cable Rack Construction
Fig. 1A

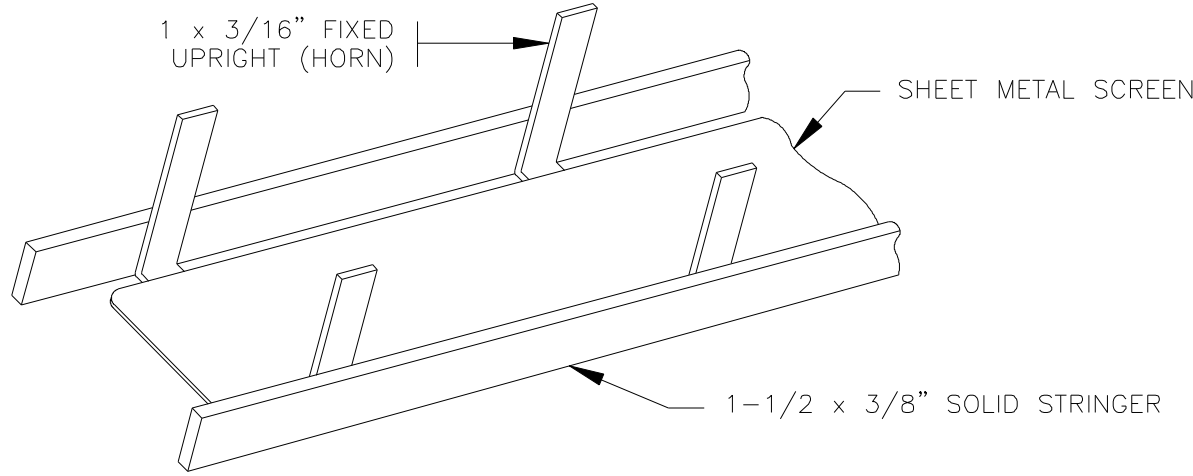

Typical Bar Type Cable Rack Construction
(Not Approved For Further Use)
Fig. 1B

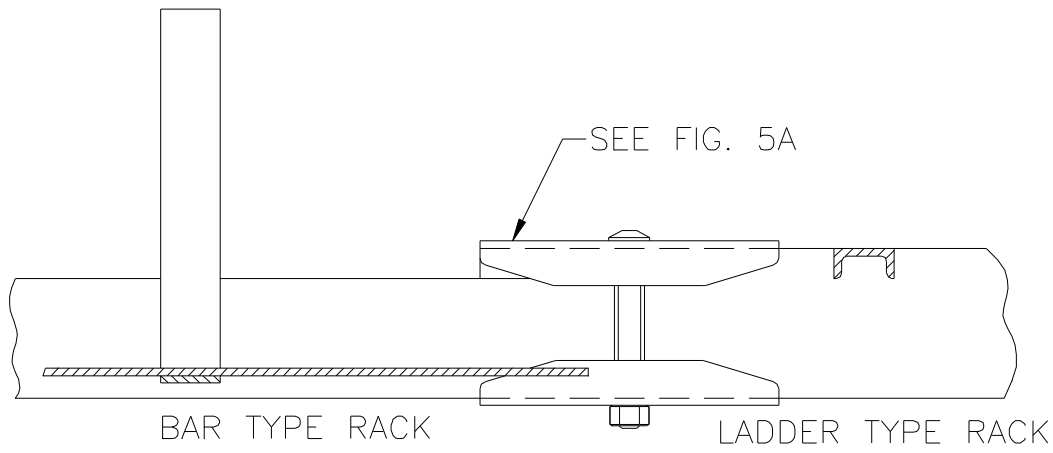

Joining Bar-Type To Ladder-Type Cable Rack Of The Same Width (refer to 1.05)

Figure 1C

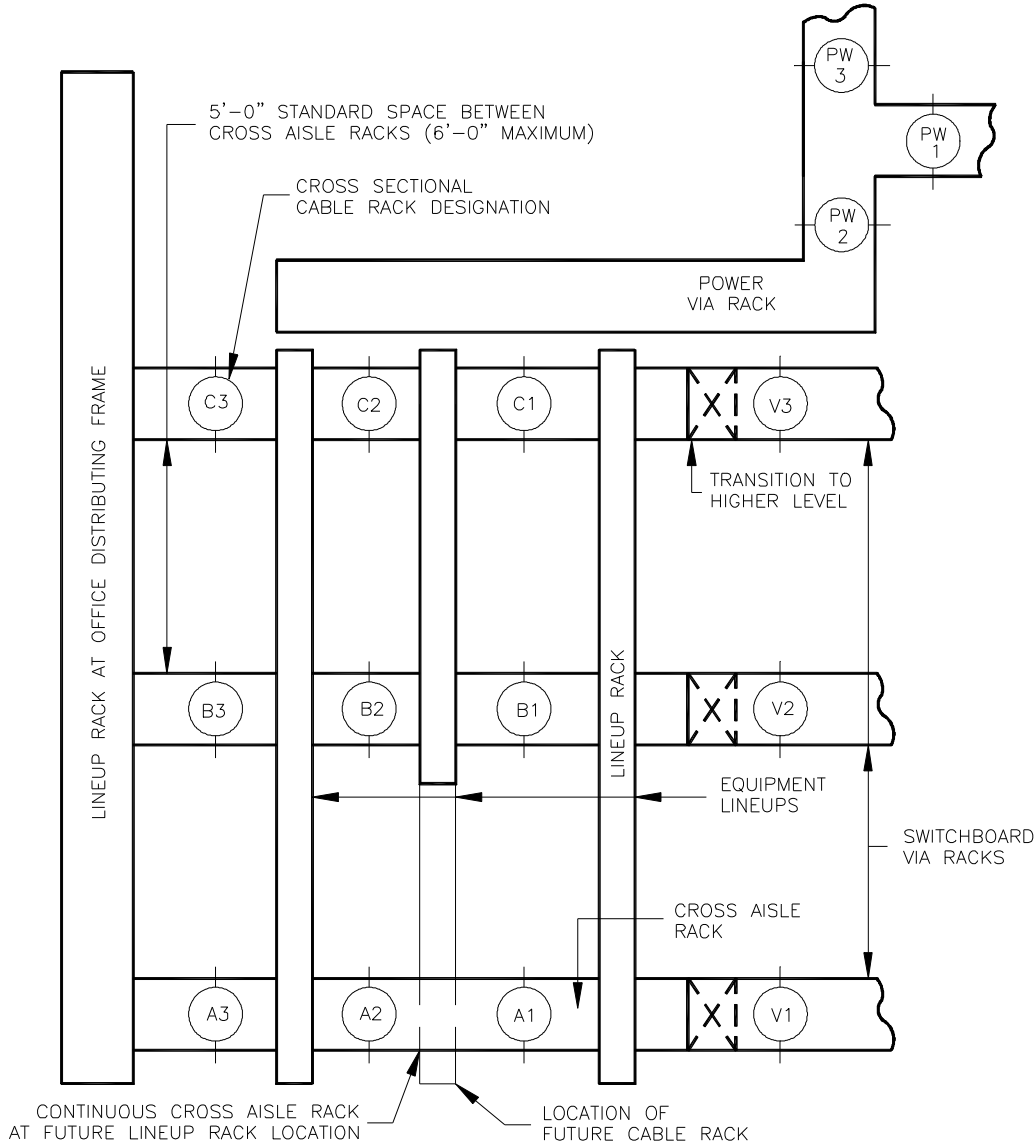

Typical Equipment Area Cross Aisle Cable Rack Scheme
Using Cross Sectional Cable Rack Designations

Fig. 2A

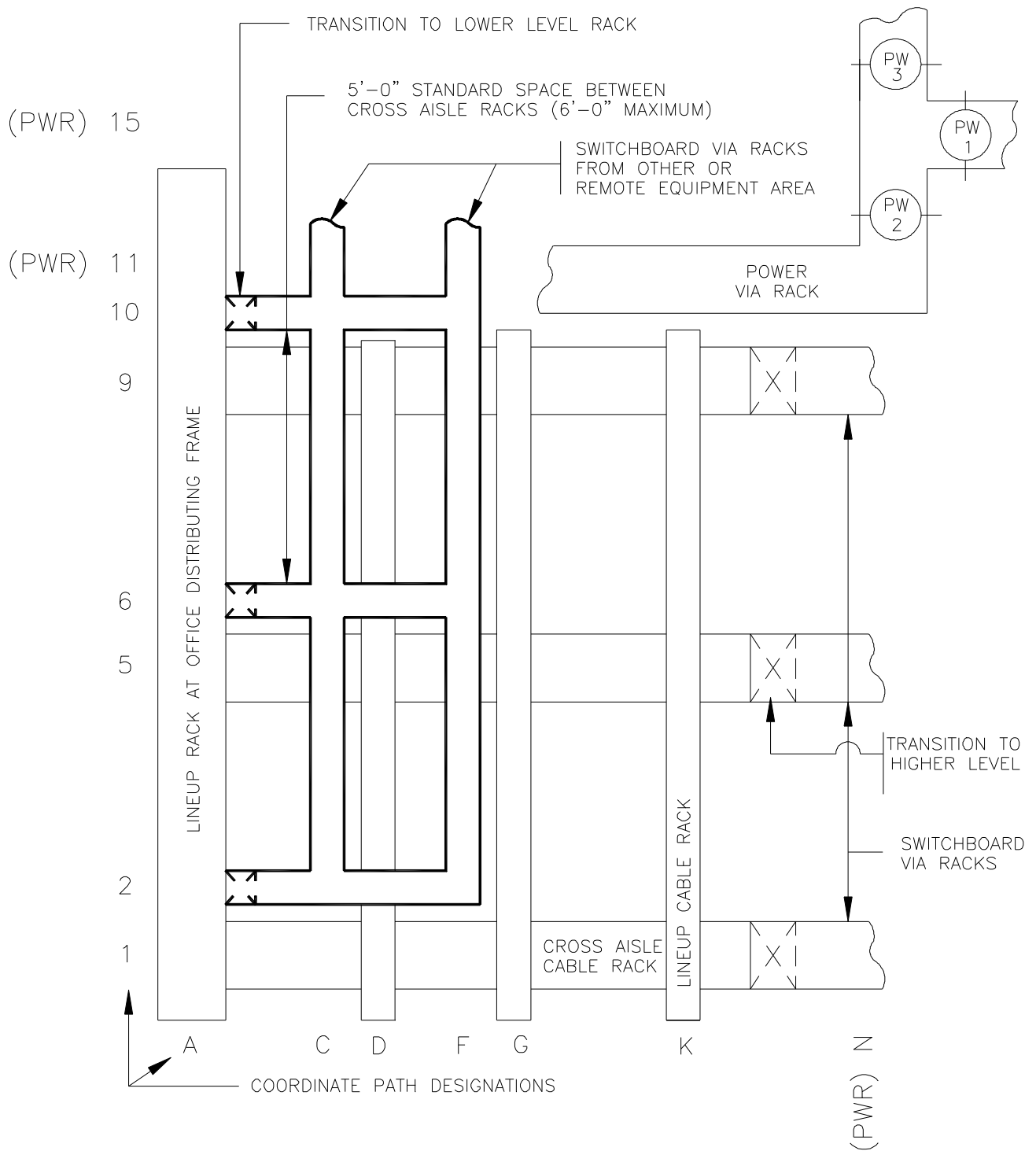

Equipment Area Cross Aisle And Via Cable Rack Scheme
Using Cross Sectional And Coordinate Path Cable Rack Designations

Fig. 2B

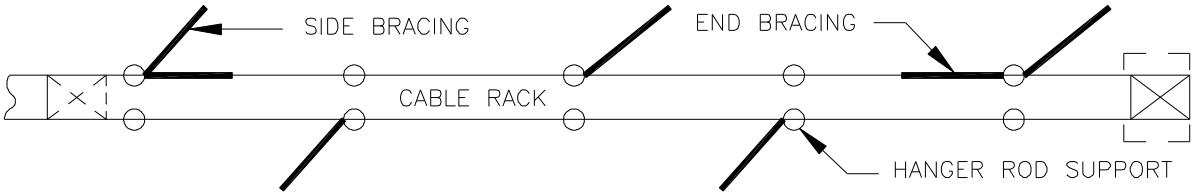

INDEPENDENT RUN OF CABLE RACK
2C-1

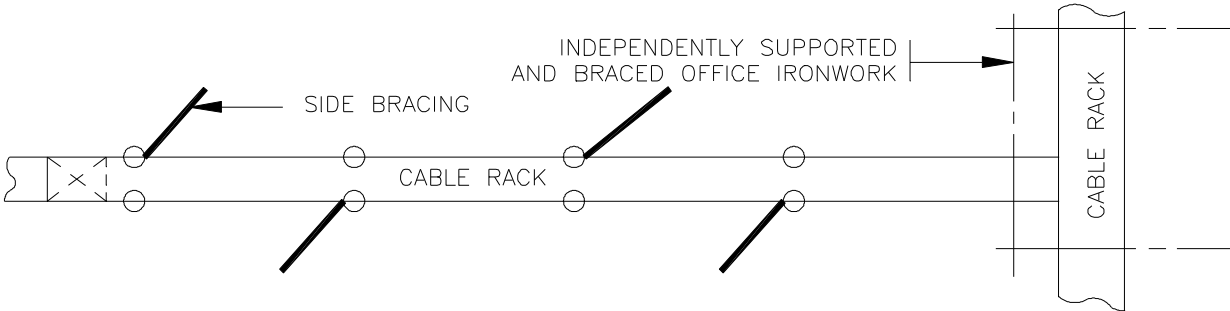

CABLE RACK INTEGRATED WITH OFFICE SUPERSTRUCTURE
(END BRACES NOT REQUIRED)
2C-2

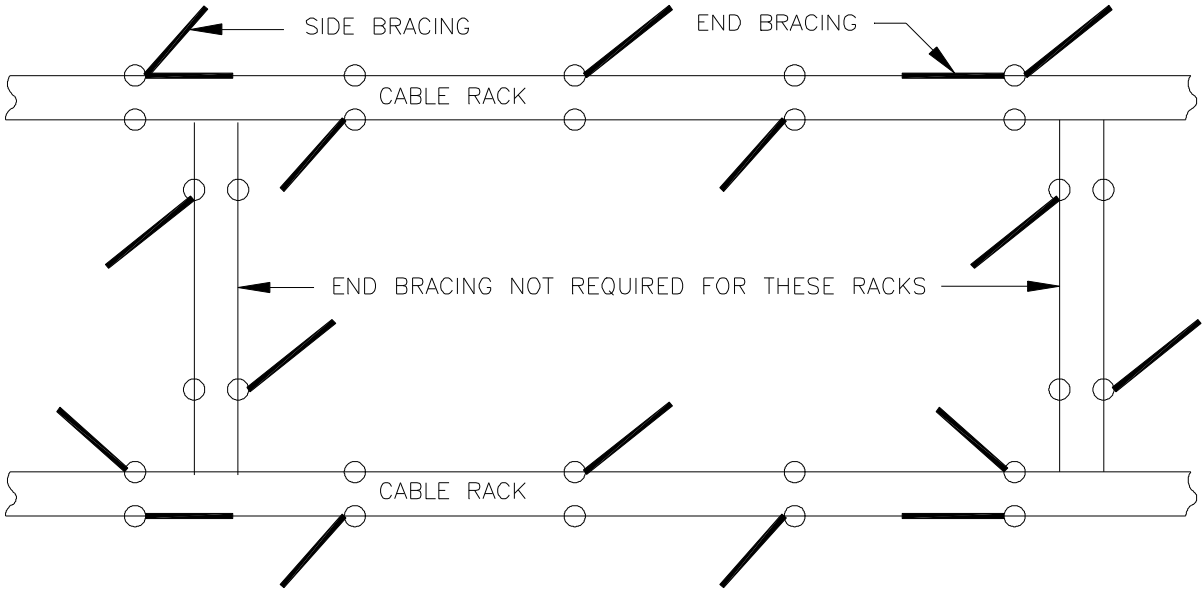

INDEPENDENTLY SUPPORTED CABLE RACK GRID
2C-3

Application Of Cable Rack Bracing
Fig. 2C

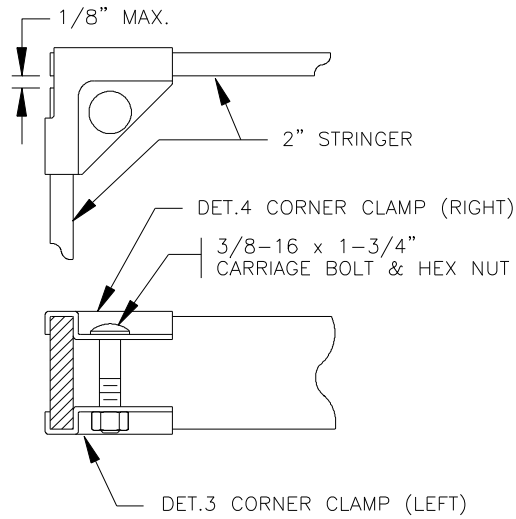

Corner Clamp - Left
Stringers Same Height
Fig. 3A

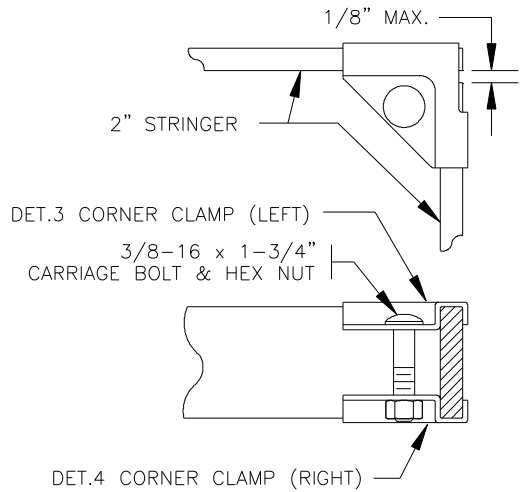

Corner Clamp - Right
Stringers Same Height
Fig. 3B

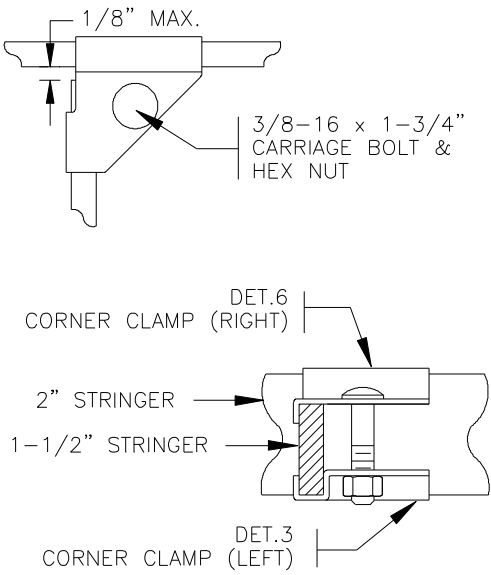

Corner Clamp - Left
Stringers Different Height
Fig. 3C

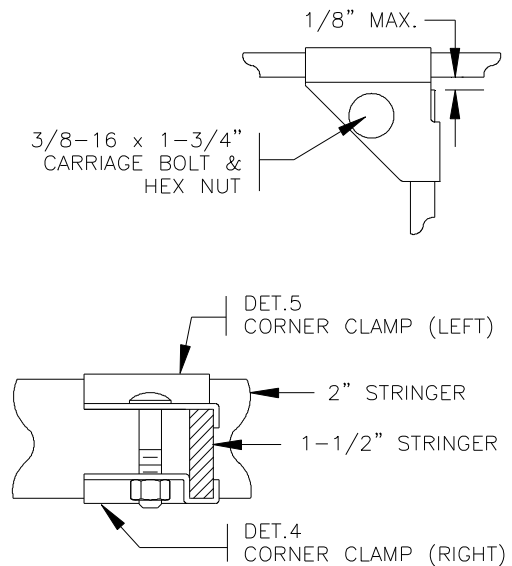

Corner Clamp - Right
Stringers Different Height
Fig. 3D

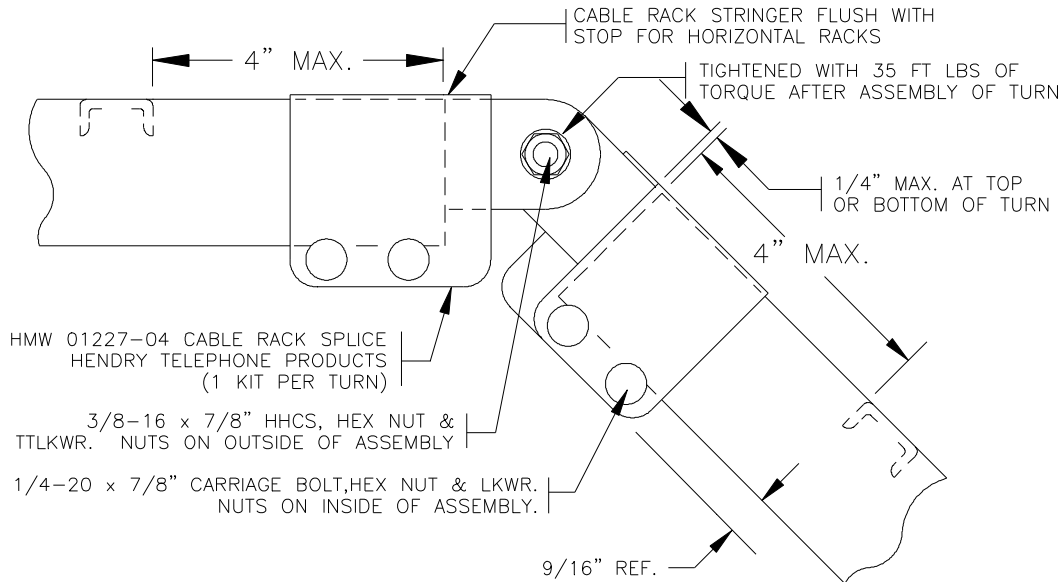

45 Degree Outside Turn

Fig. 4A

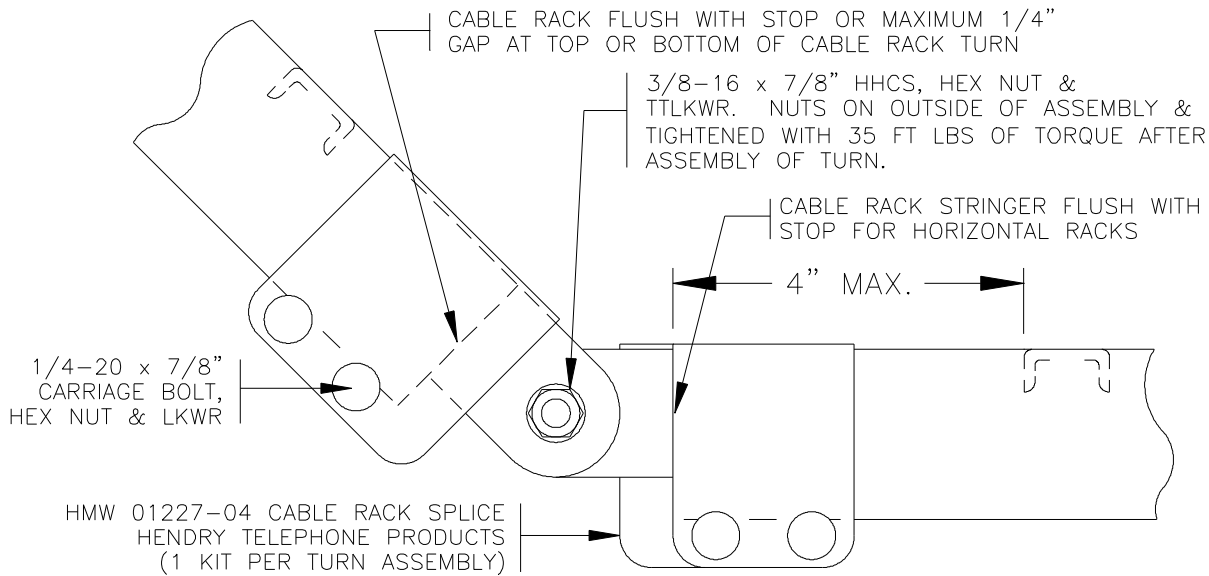

45 Degree Inside Turn

Fig. 4B

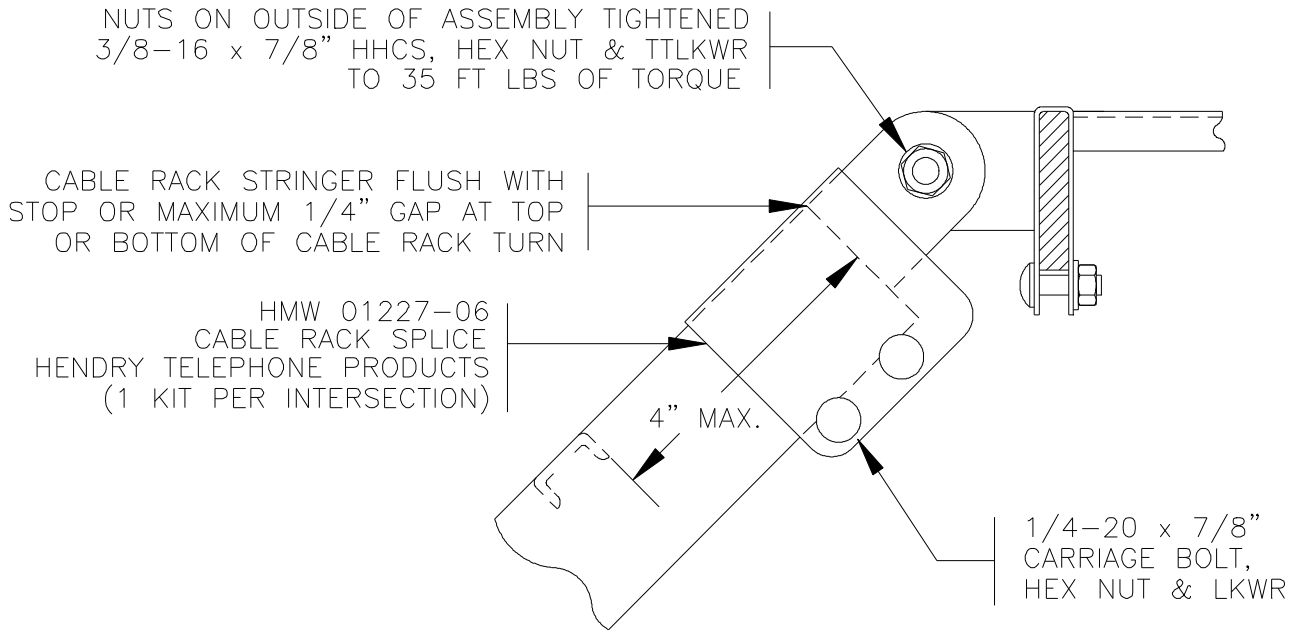

45 Degree Right Angle Junction

Fig. 4C

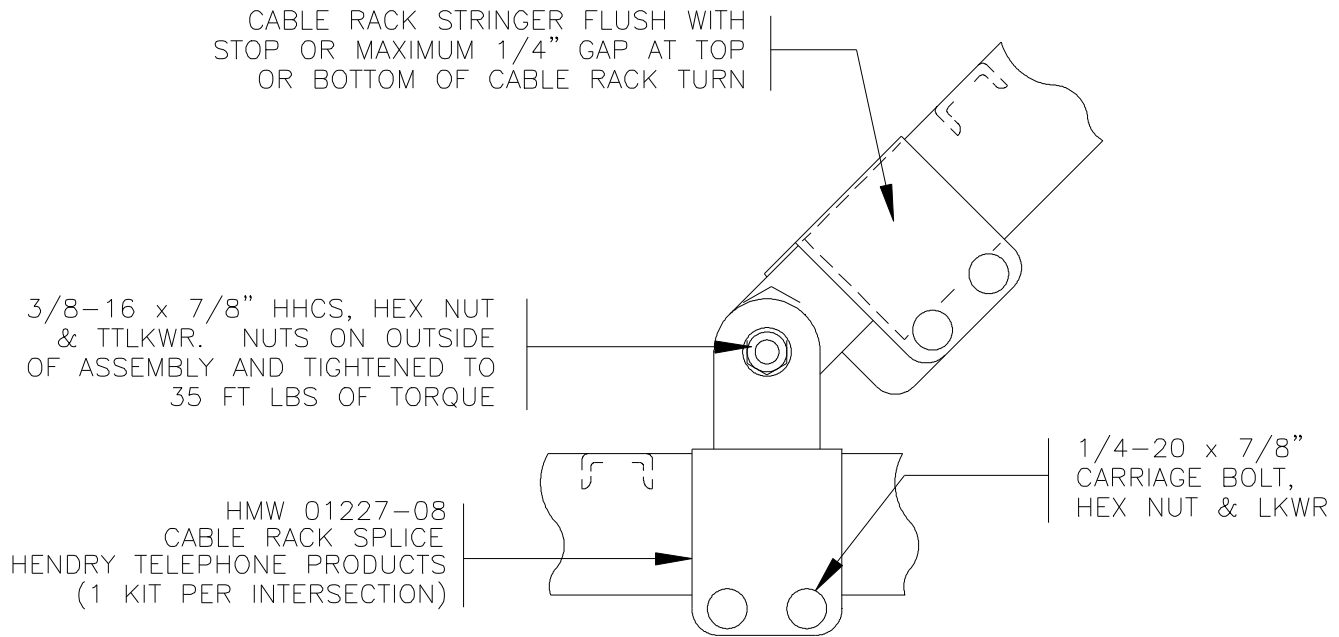

45 Or 90 Degree Intermediate Junction
(45 Degree Shown)

Fig. 4D

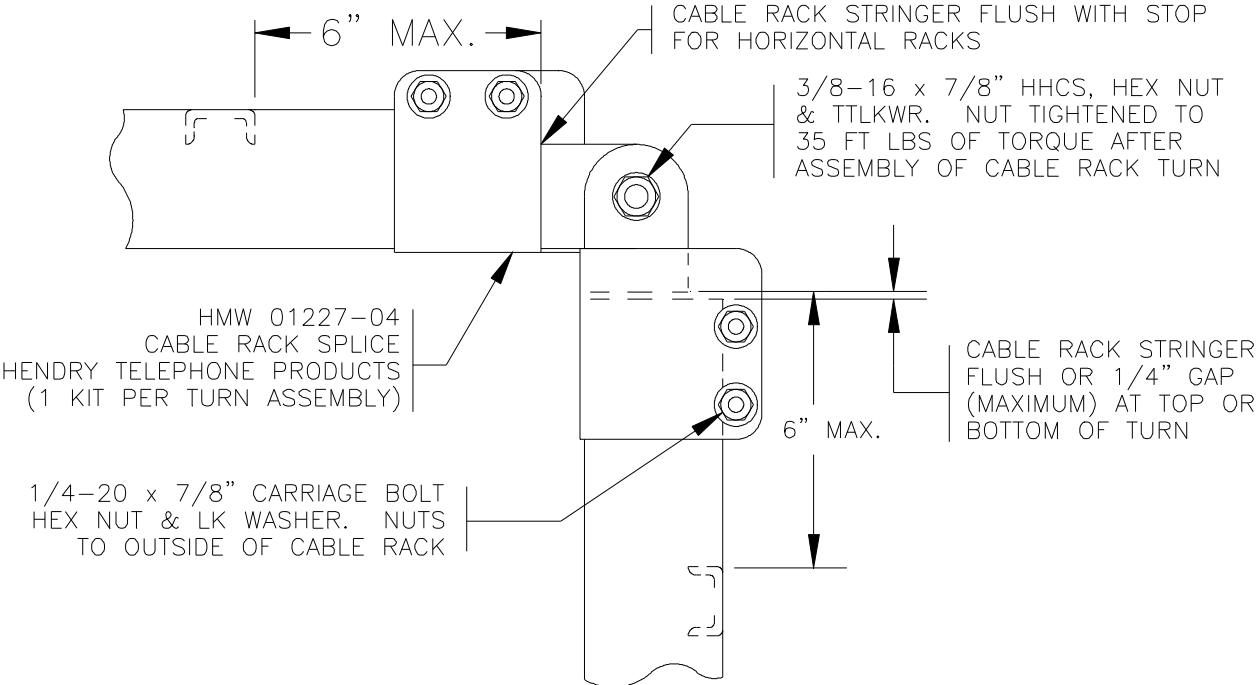

90 Degree Outside Turn

Fig. 4E

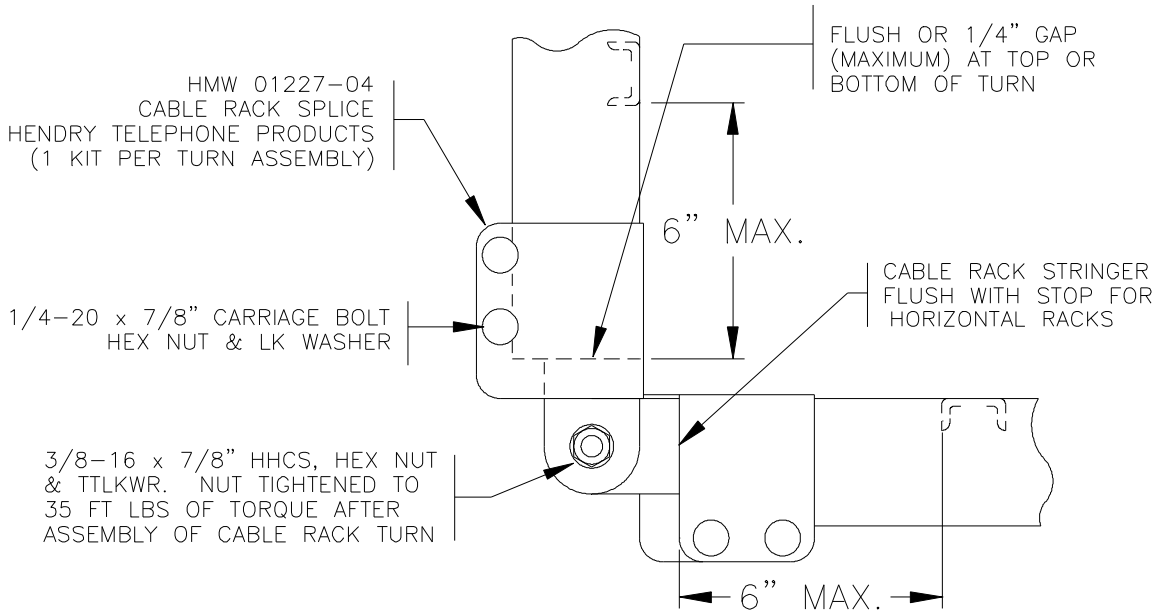

90 Degree Inside Turn

Fig. 4F

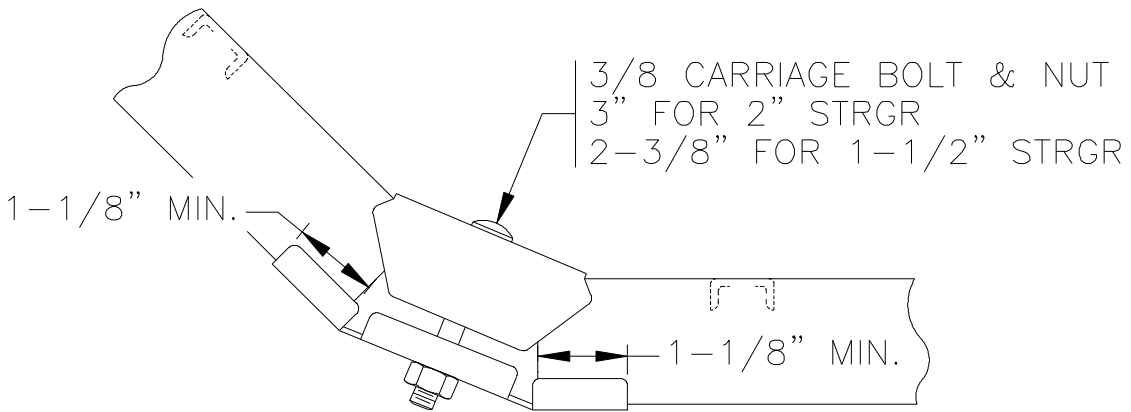

45 Degree Edge Clamp for Outside Turn

Fig. 4G

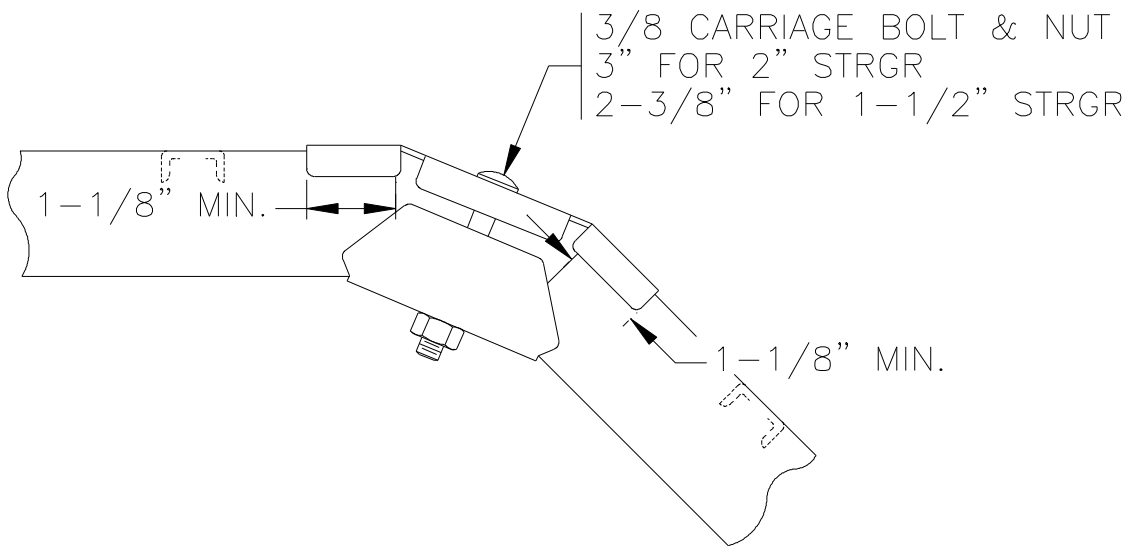

45 Degree Edge Clamp for Outside Turn

Fig. 4H

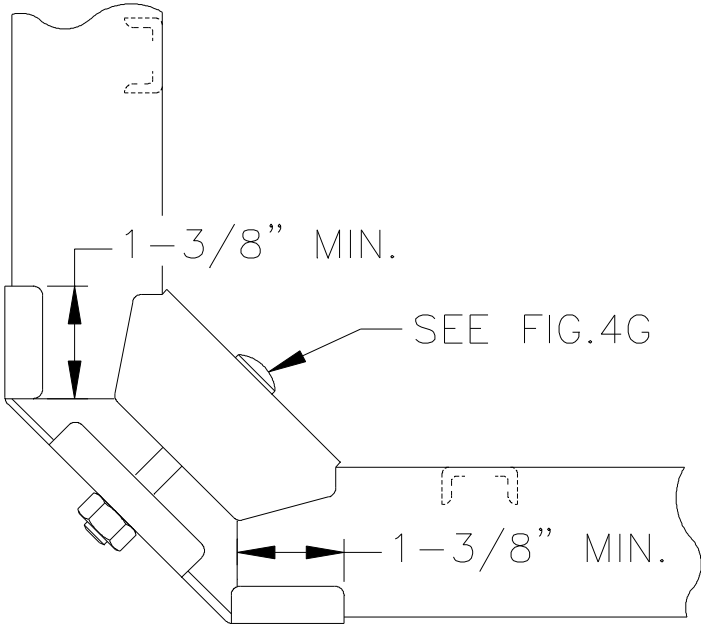

90 Degree Edge Clamp for Inside Turn
Fig. 4I

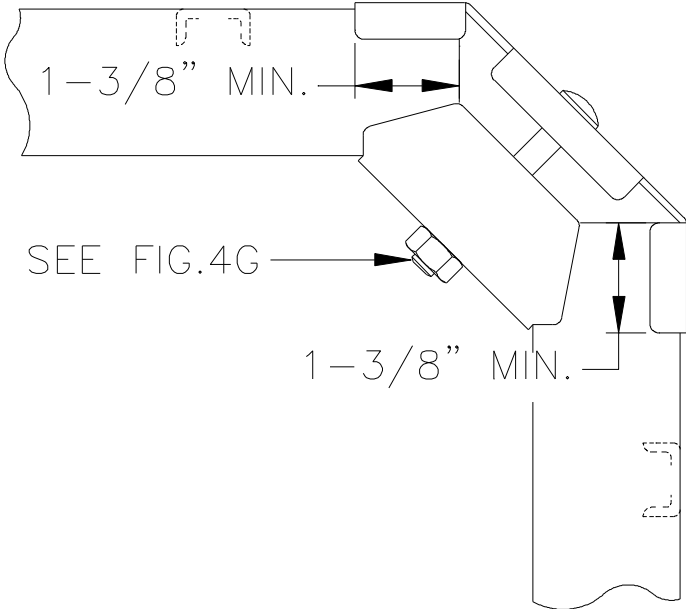

90 Degree Edge Clamp for Outside Turn
Fig. 4J

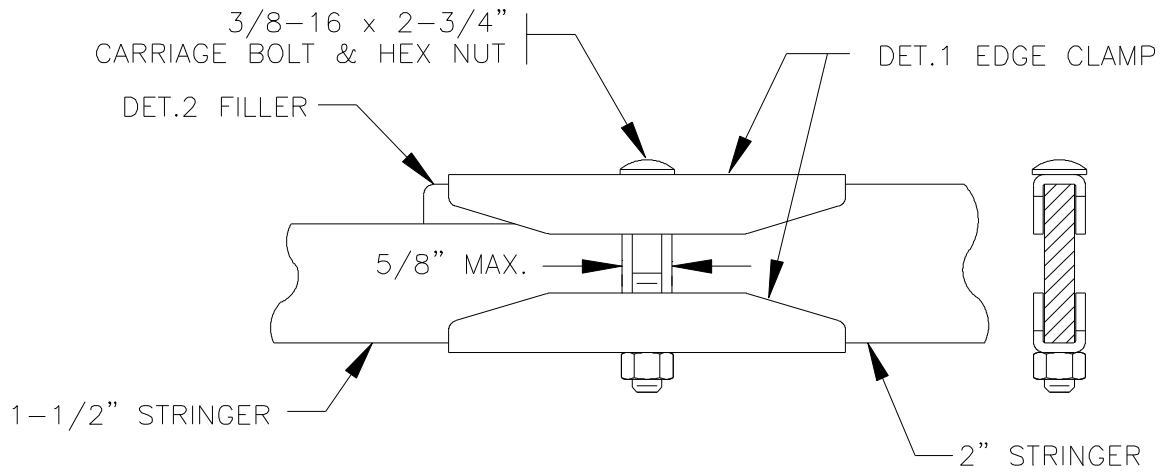

In-Line Junction - Cable Rack Stringers
(1-1/2 To 2" Stringers Shown)

Fig. 5A

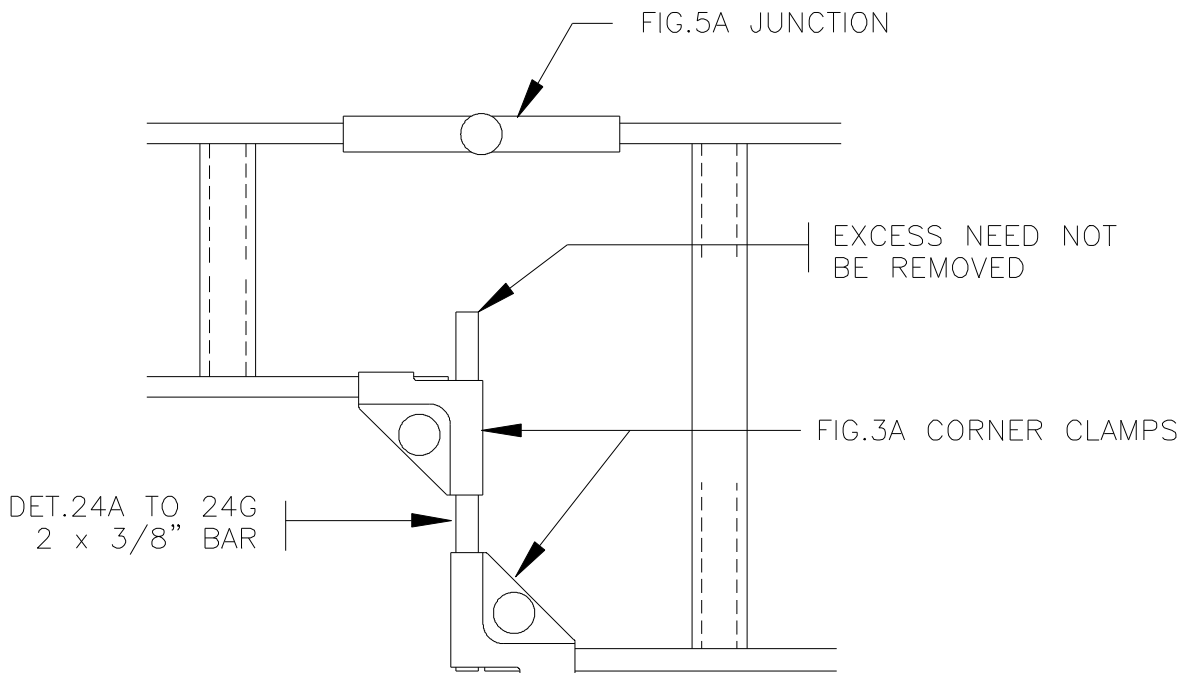

In-Line Junction - Of Different Widths
Smaller Rack To One Side (See Fig. 5D)

Fig. 5B

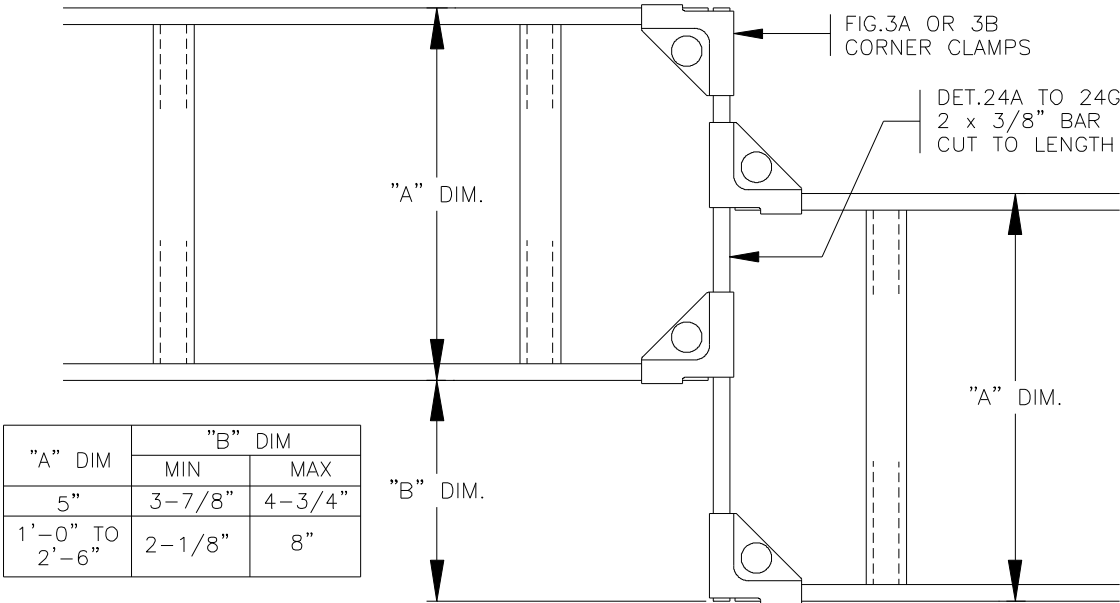

In-Line Junction - Small Horizontal Offset Less Than Width Of Rack
Cable Racks In Same Plane

Fig. 5C

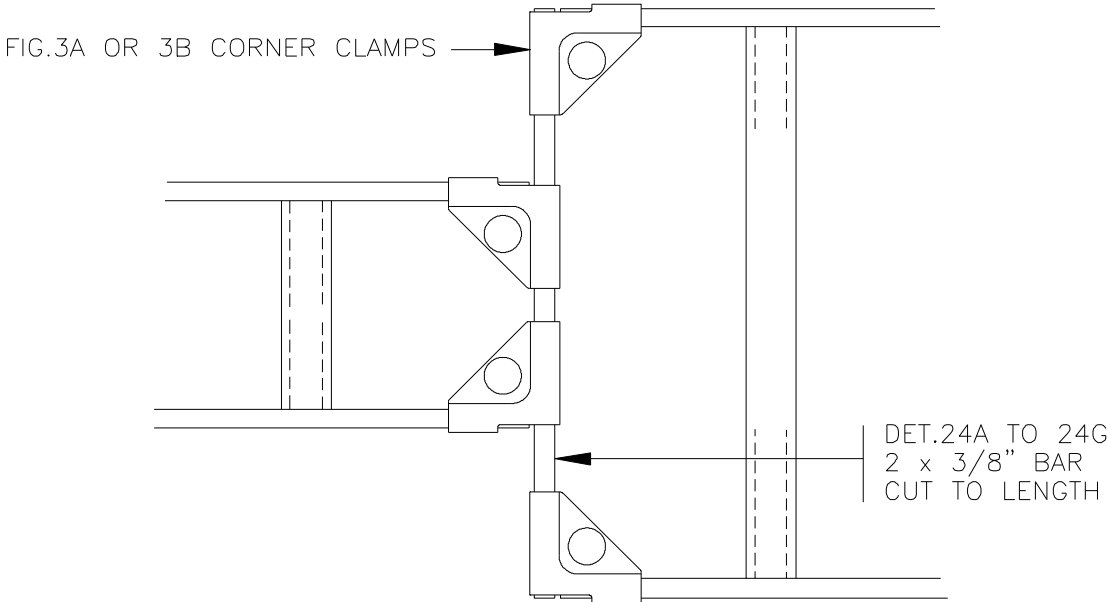

In-Line Junction - Racks Of Different Widths
Smaller Rack Approximately Centered (See Fig. 5B)

Fig. 5D

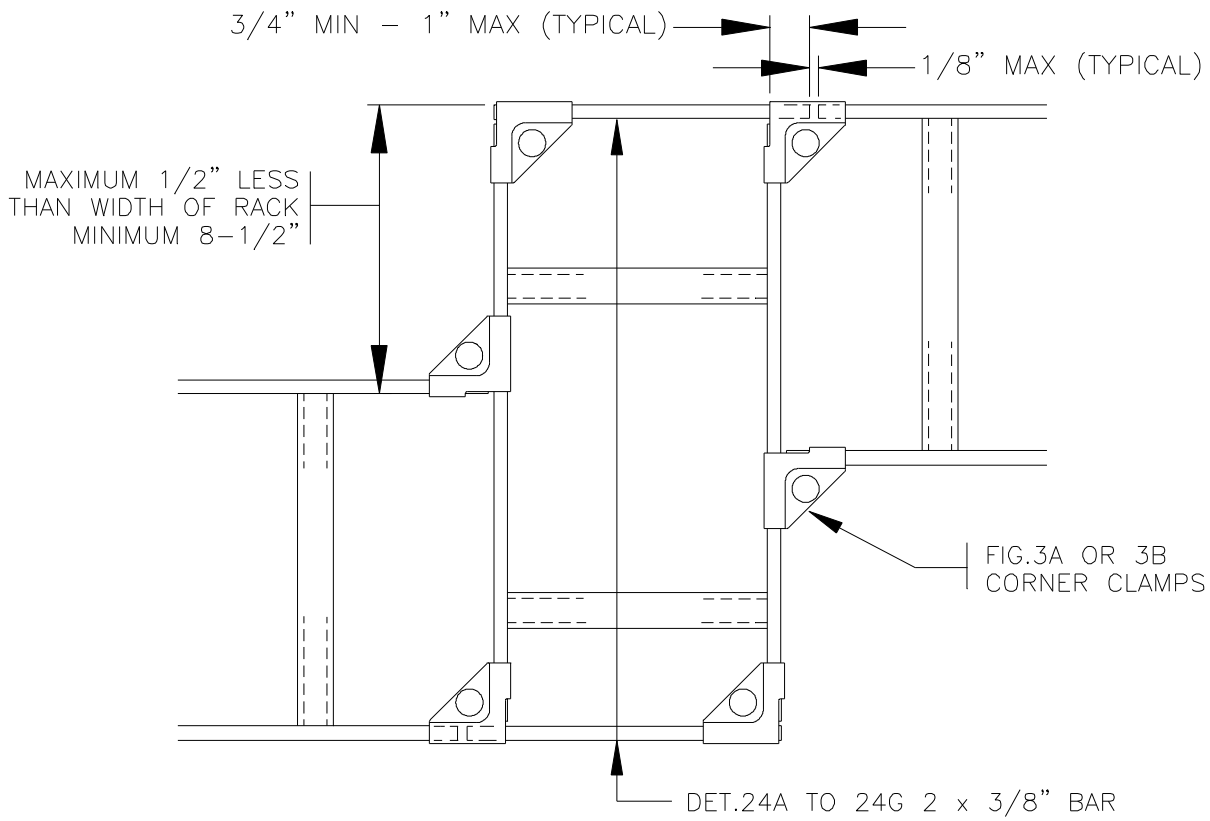

In-Line Junction - Large Horizontal Offset Less Than Width Of Rack

Fig. 5E

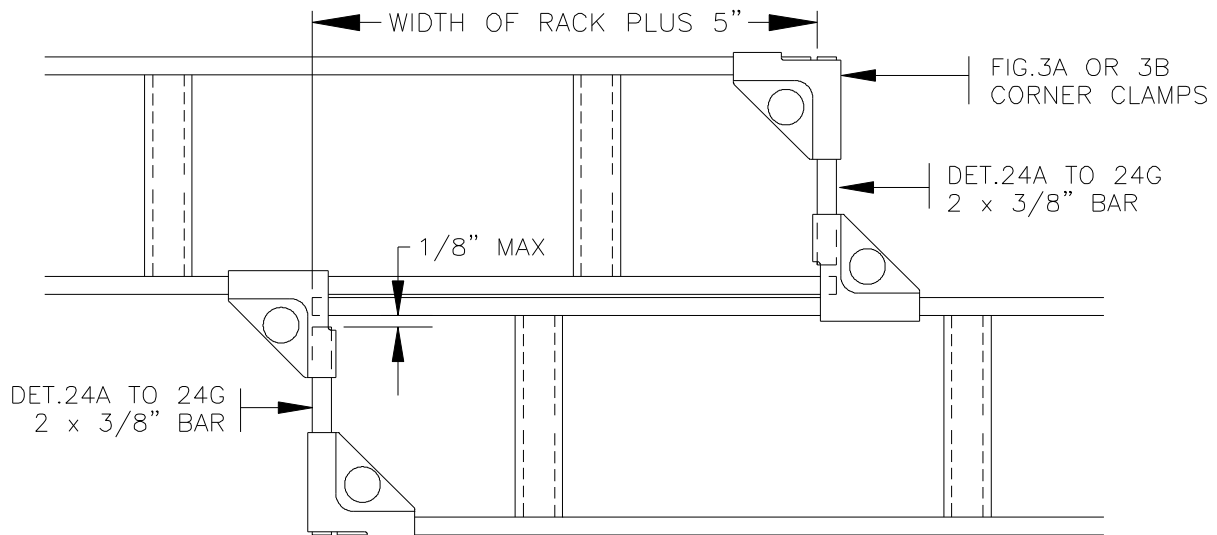

In-Line Junction - Adjacent Cable Racks

Fig. 5F

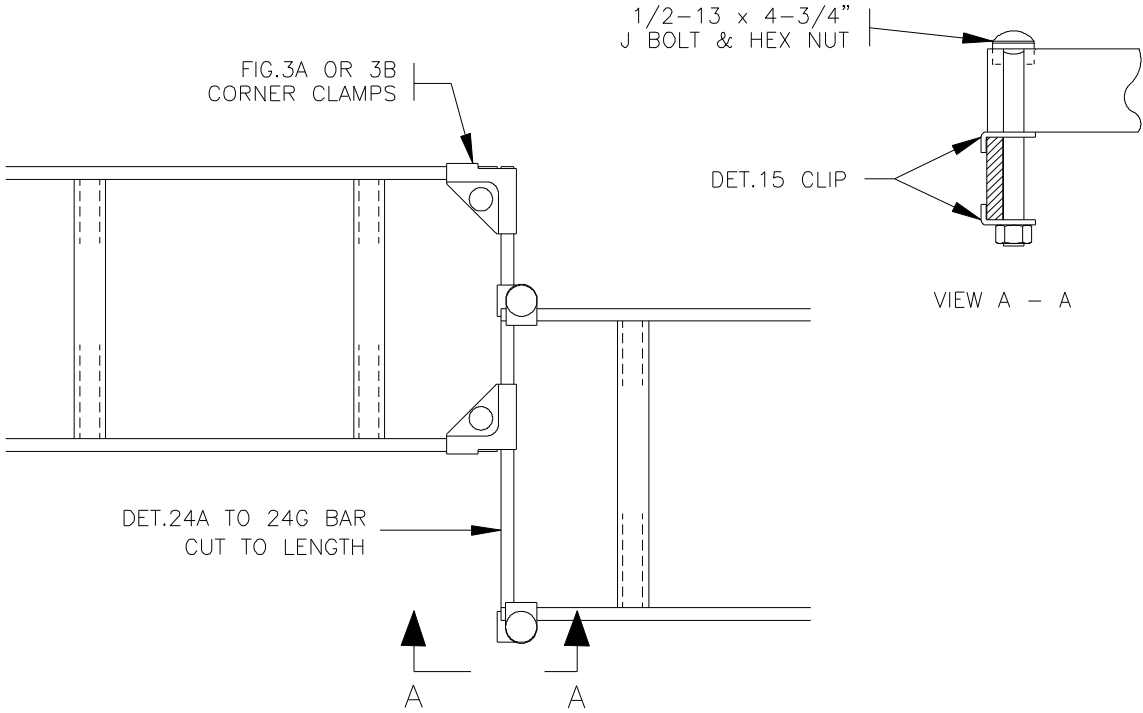

In-Line Junction - Small Horizontal Offset Less than Width Of Rack
2 Inch Vertical Offset In Levels Of Cable Rack

Fig. 5G

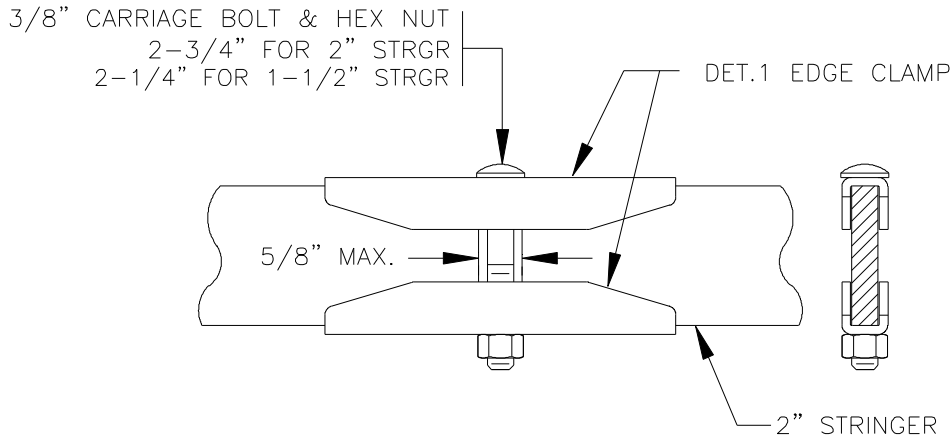

Straight Clamp for Stringers of Same Width

Fig. 5H

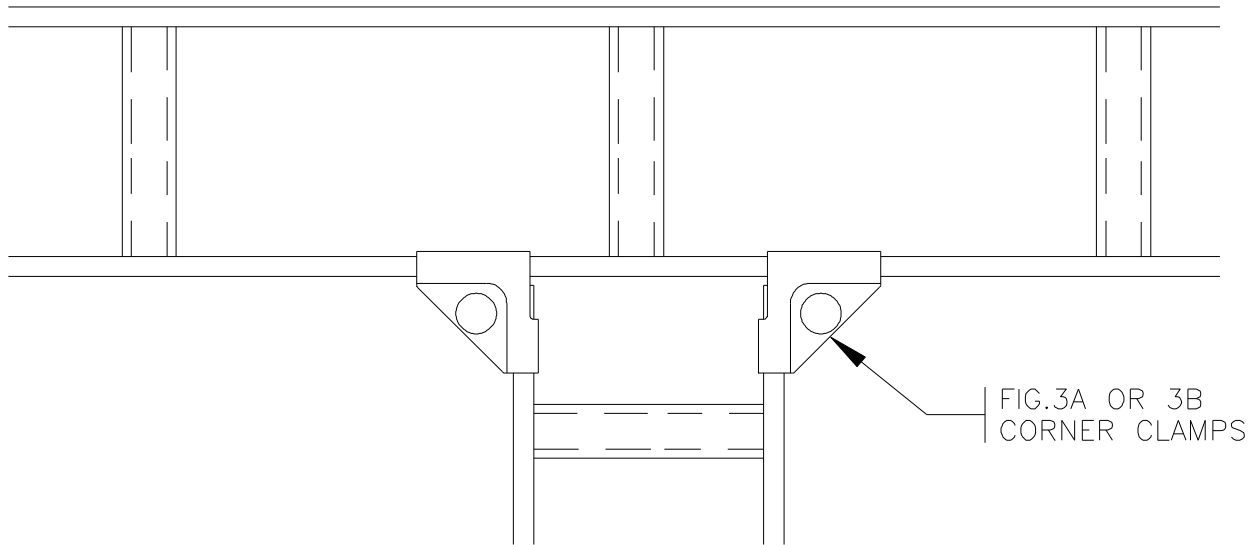

Right Angle Junction - Cable Racks In Same Plane

Fig. 6A

NOTE 6B1. J BOLT MAY BE FASTENED TO SAME STRINGER OF LINEUP CABLE RACK WHERE INTERFERENCE WITH CROSS STRAPS OF CROSS AISLE CABLE RACK OCCURS.

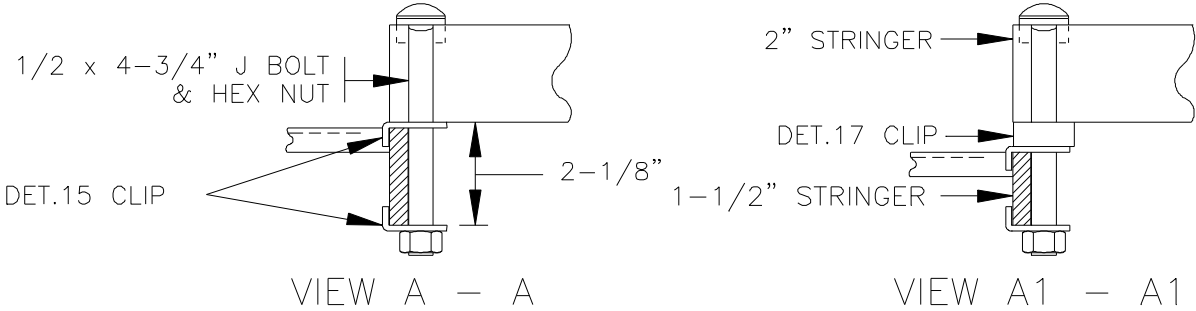
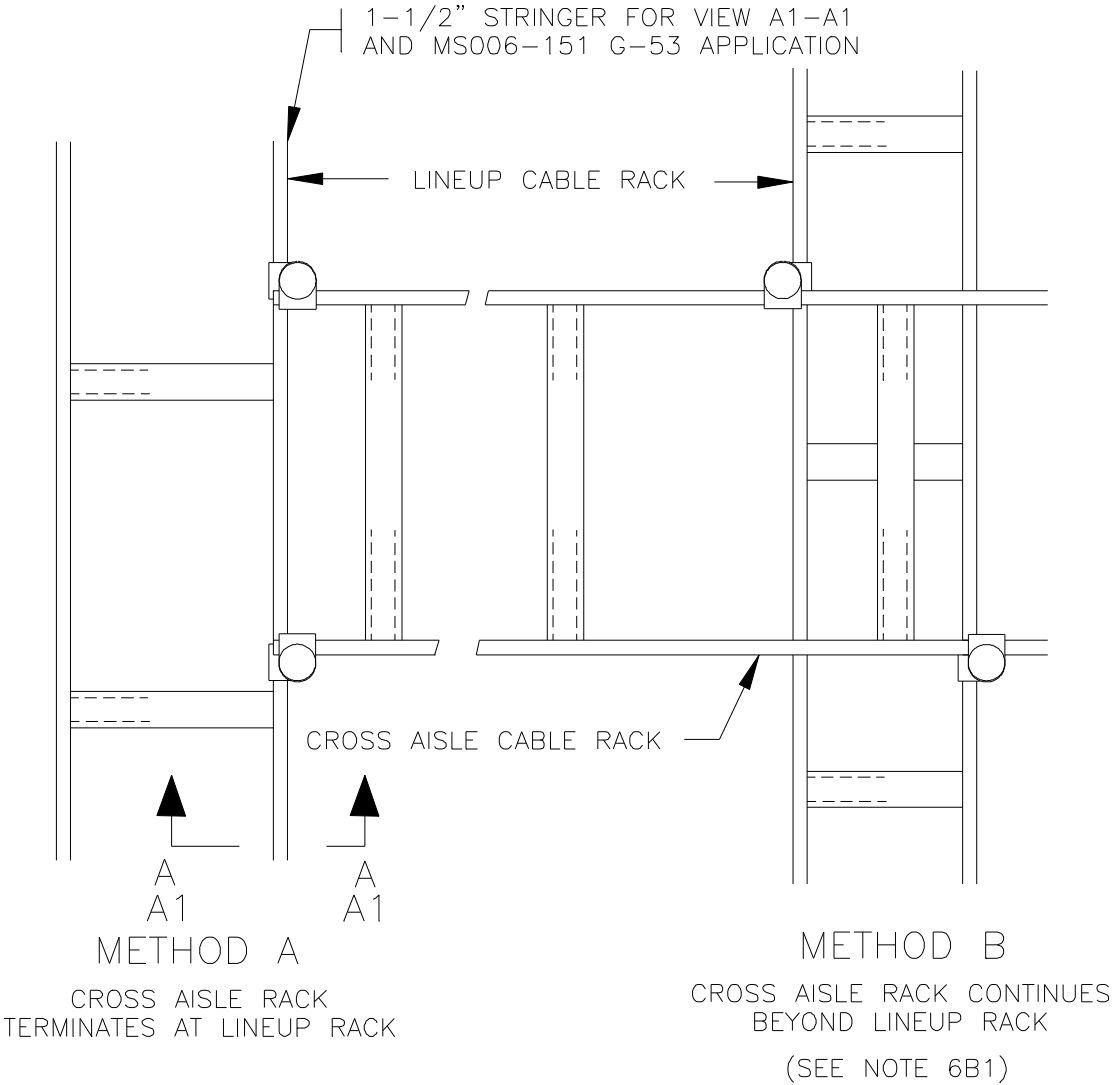

Right Angle Junction - Lineup And Cross Aisle Cable Racks
Cross Aisle Rack Raised 2 Inches Two Clear Apparatus

Fig. 6B

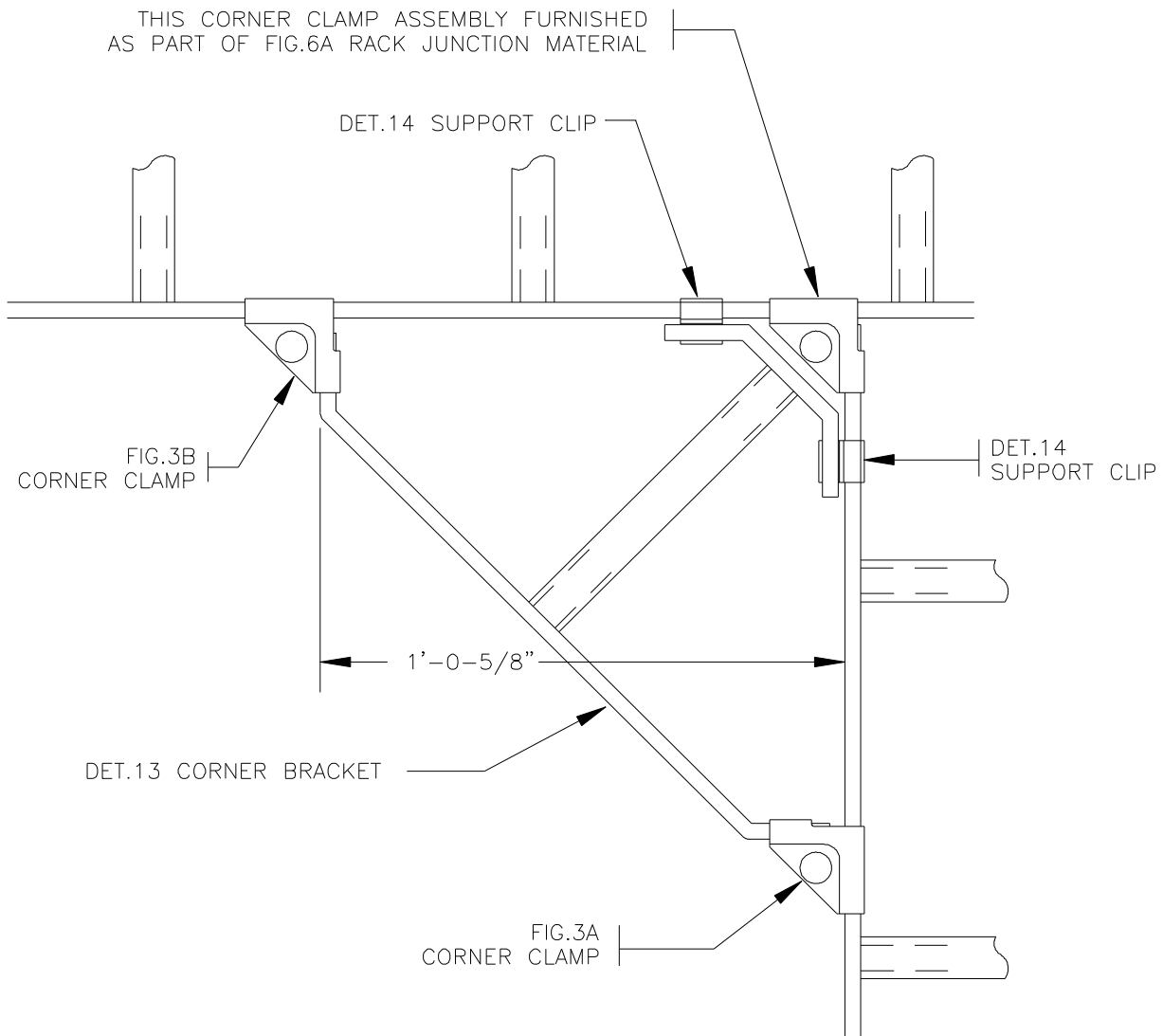

Right Angle Junction - Additional Cable Support
Cable Racks In Same Plane

Fig. 6CA

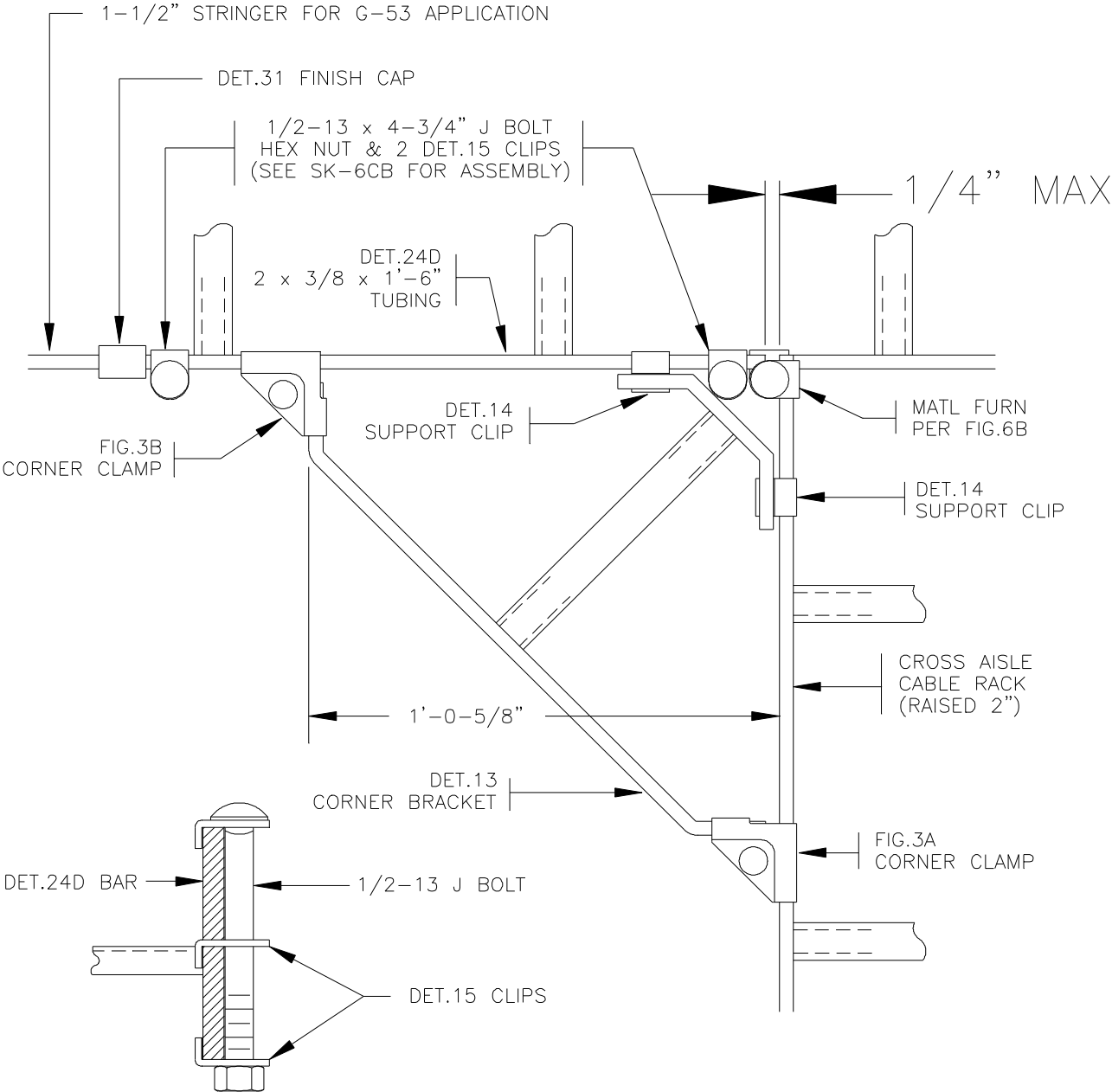

SK - 6CB
(SEE FIG. 6B
VIEW A1-A1 FOR
1-1/2" STRINGER)

Right Angle Junction - Additional Cable Support
2 Inch Difference In Level Of Cable Racks

Fig. 6CB

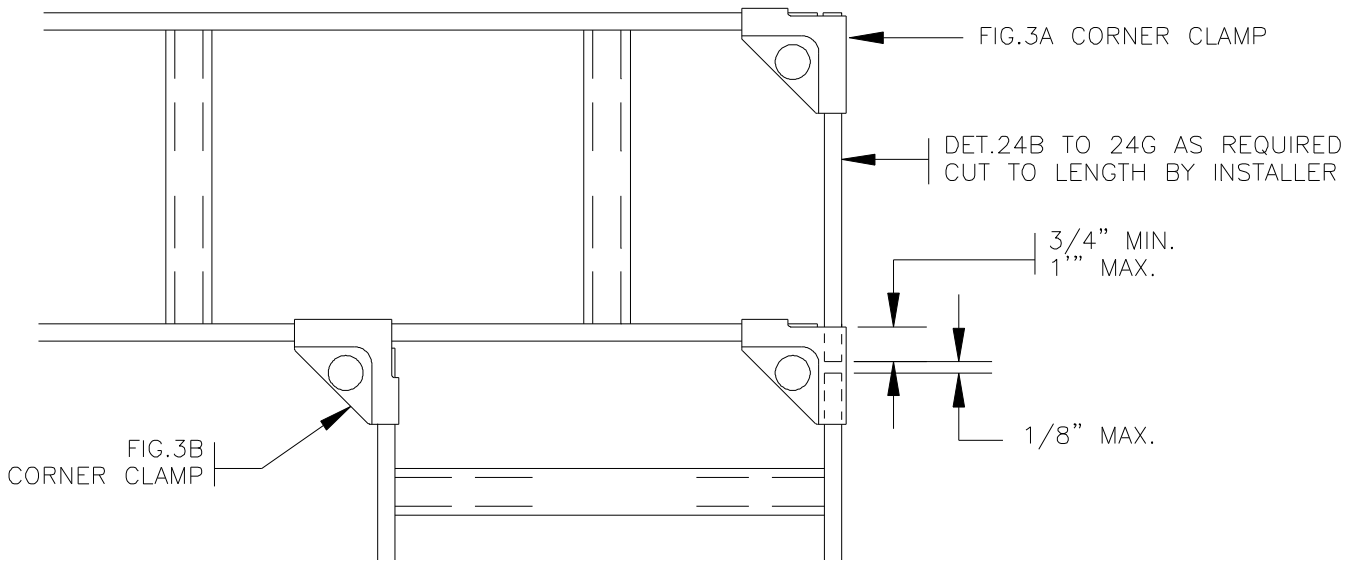

Right Angle Junction - 90 Degree Turn
Cable Racks In Same Plane

Fig. 6D

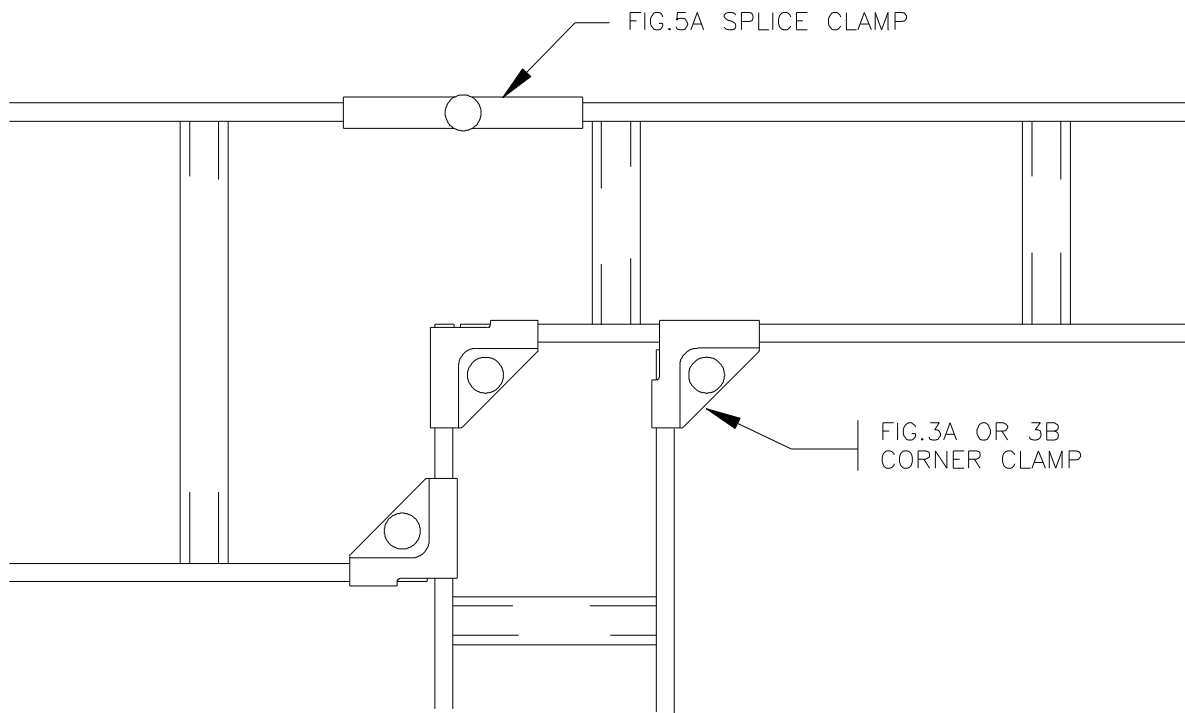

Right Angle Junction - Three Cable Racks Of Different Widths

Fig. 6E

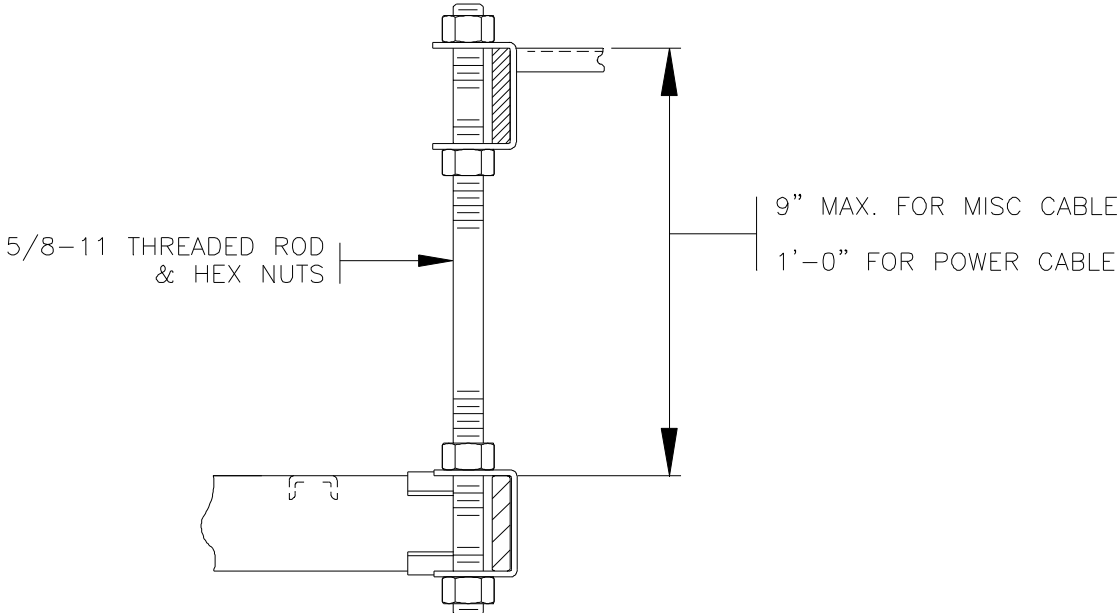

SECT. A - A

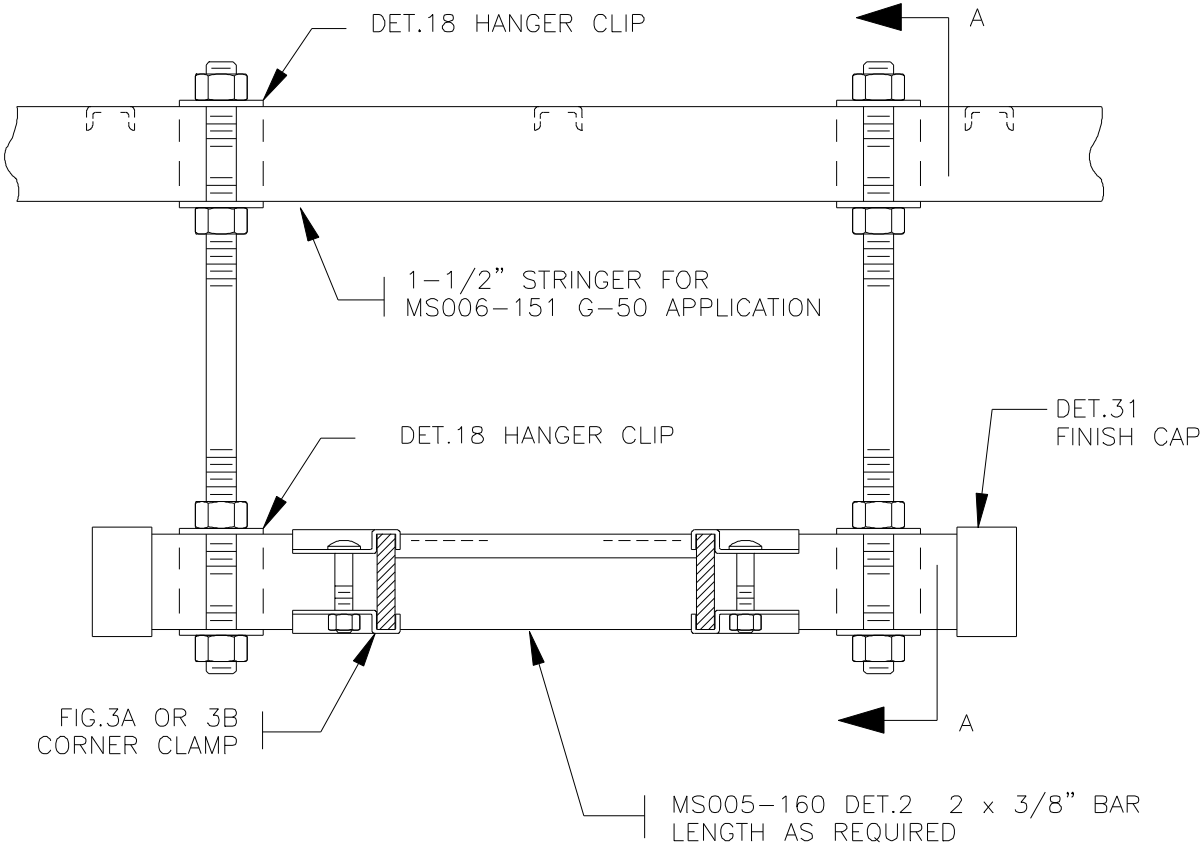

Right Angle Junction - Small Vertical Offset

Fig. 6F

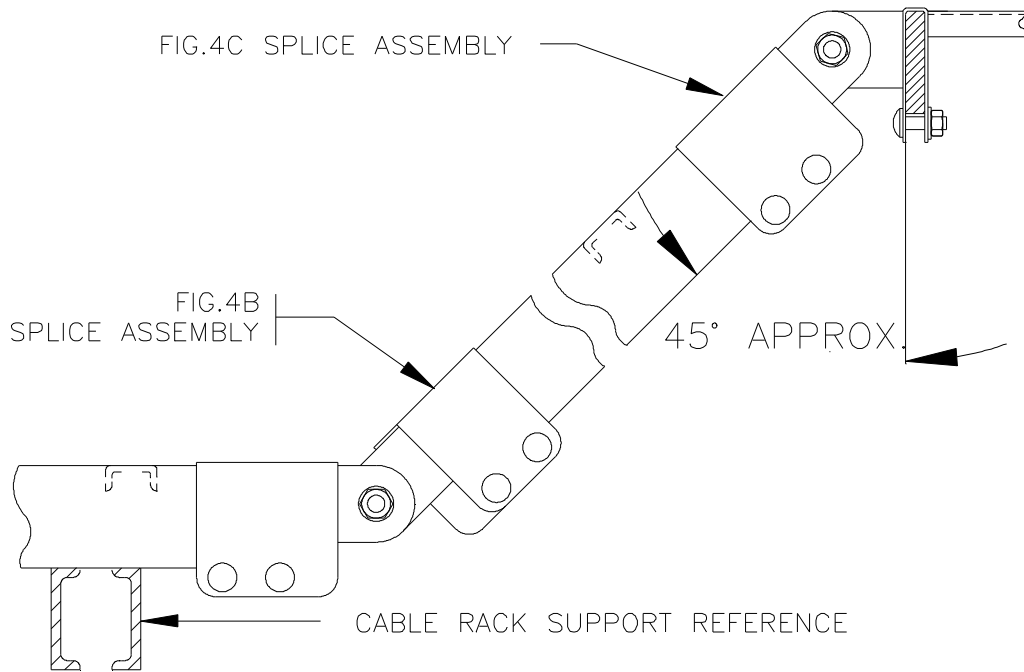

Right Angle Junction - Large Vertical Offset
Connecting Cable Rack Terminates At End Of Junctioning Cable Rack

Fig. 6G

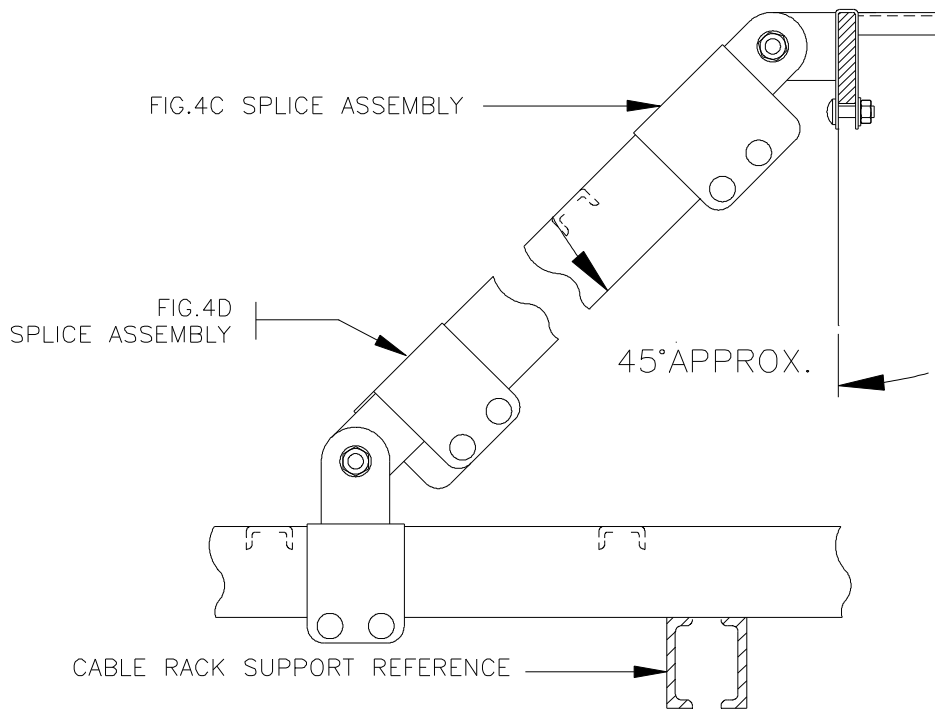

Right Angle Junction - Large Vertical Offset
Intermediate Junction Of Connecting Cable Rack

Fig. 6H

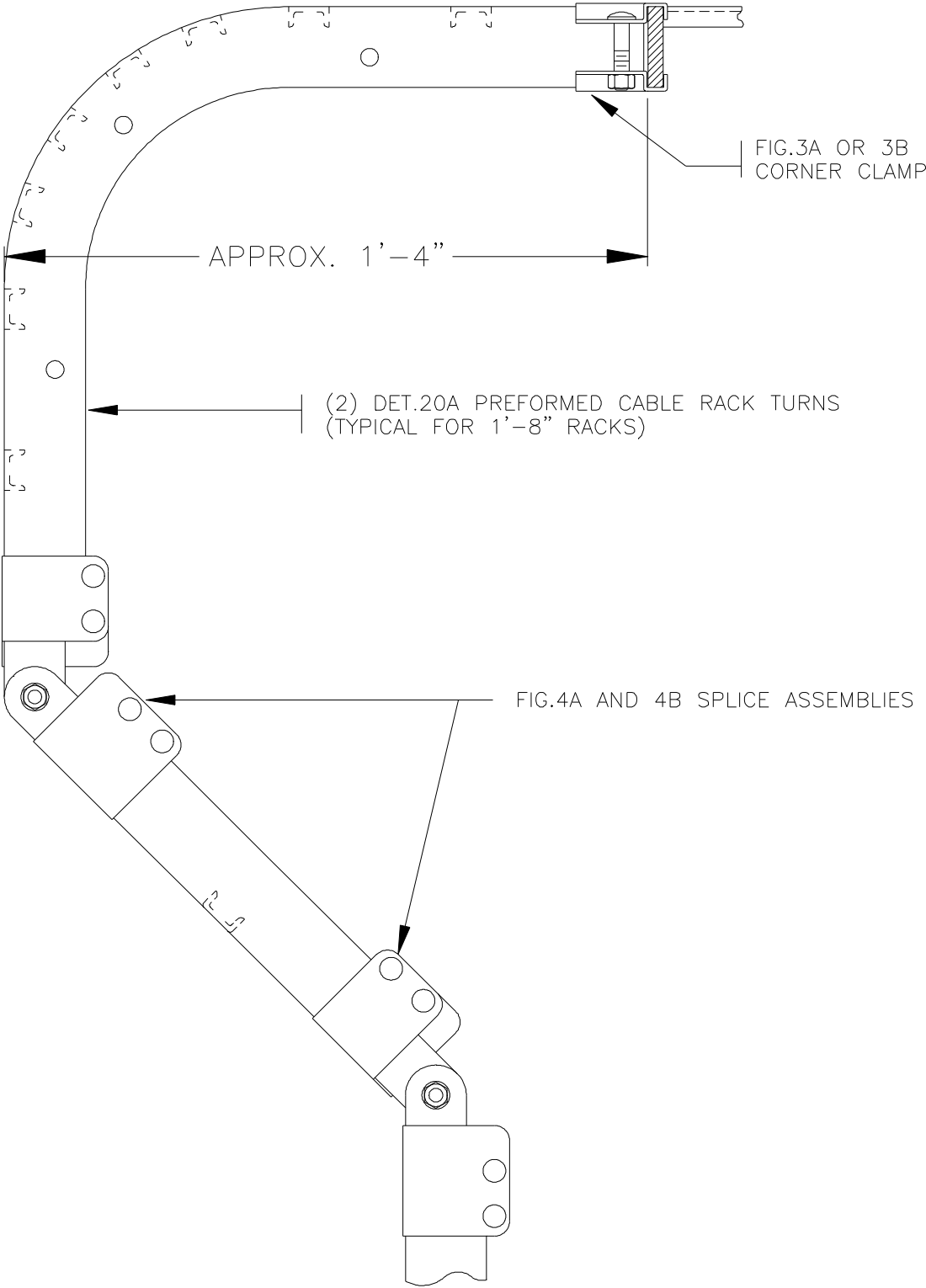

Right Angle Junction - Vertical To Horizontal Rack
Large Cable Radius

Fig. 6J

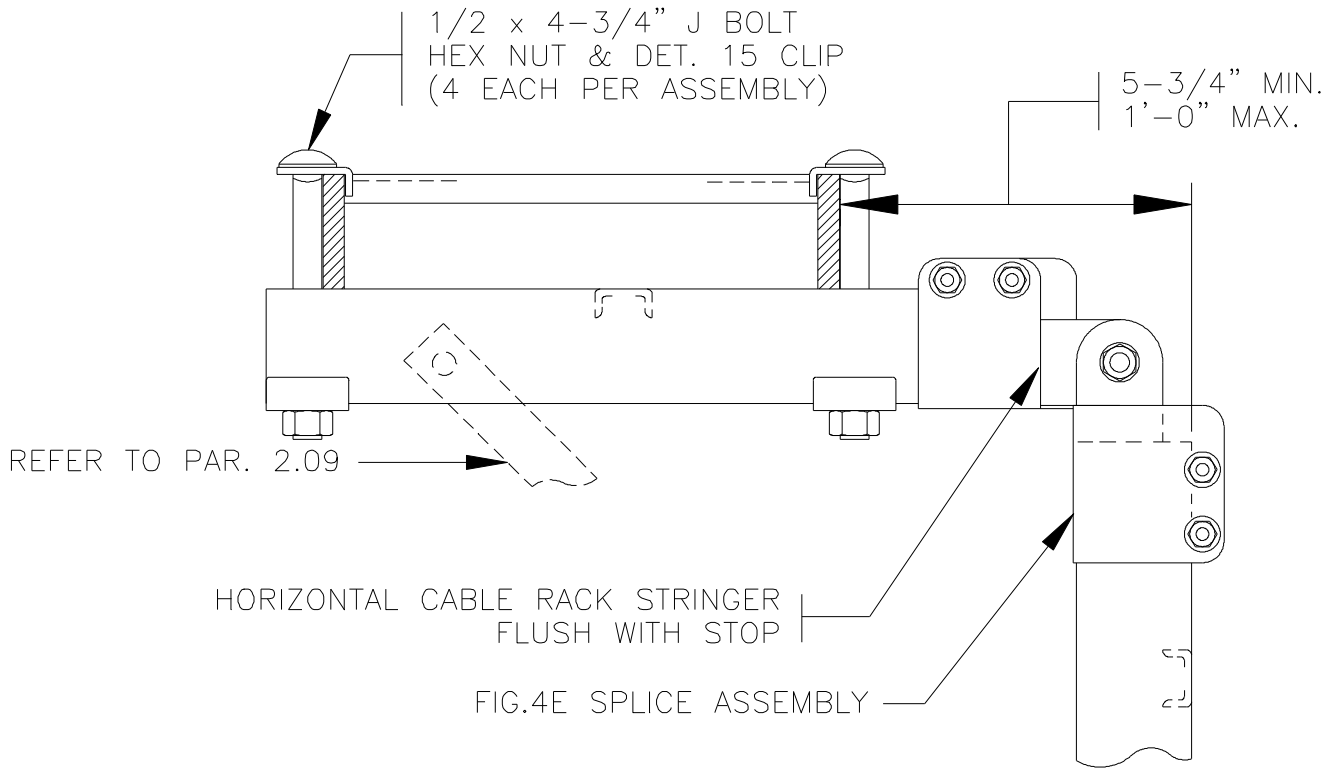

Right Angle Junction - Vertical To Horizontal Rack
Small Cable Radius

Fig. 6K

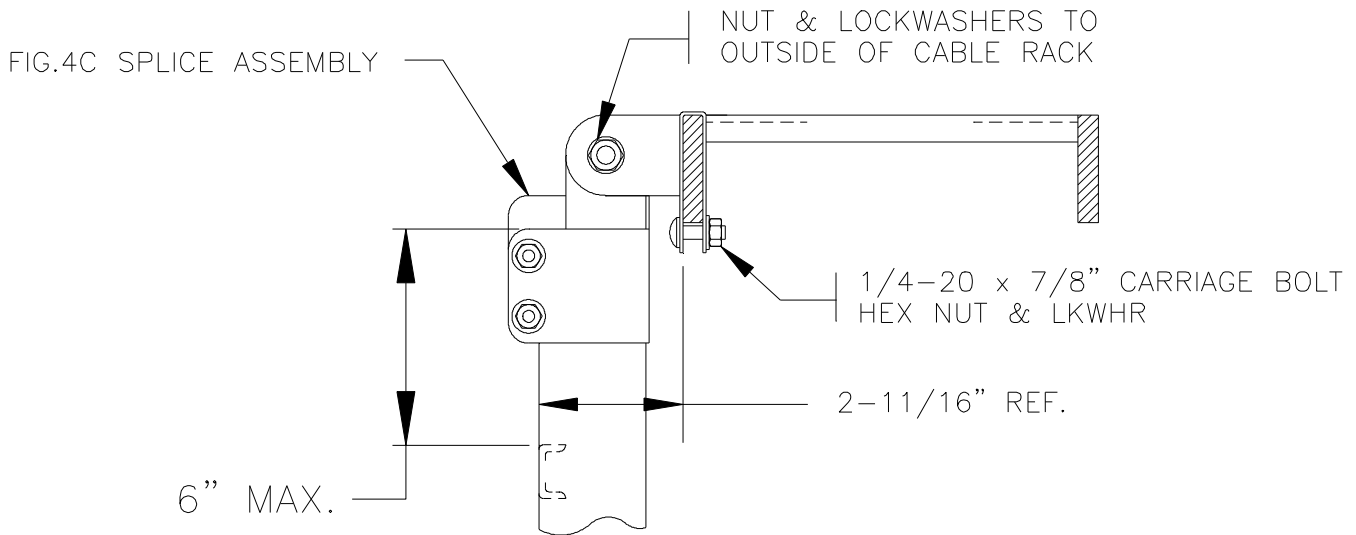

Right Angle Junction - Abrupt Cable Radius

Fig. 6L

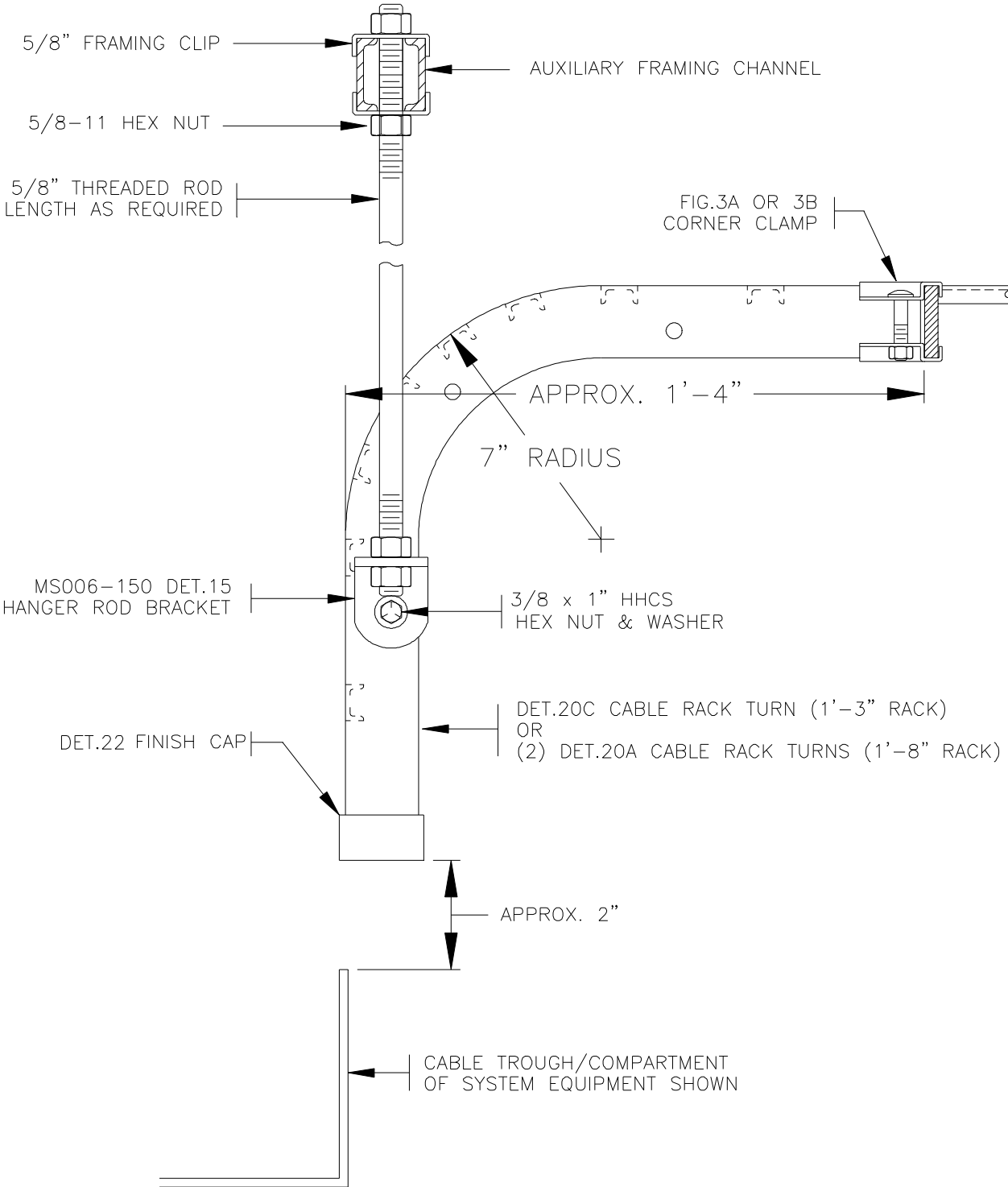

Right Angle Junction - Cable Transition Between Horizontal Racks That Are Vertically Offset

Fig. 6M

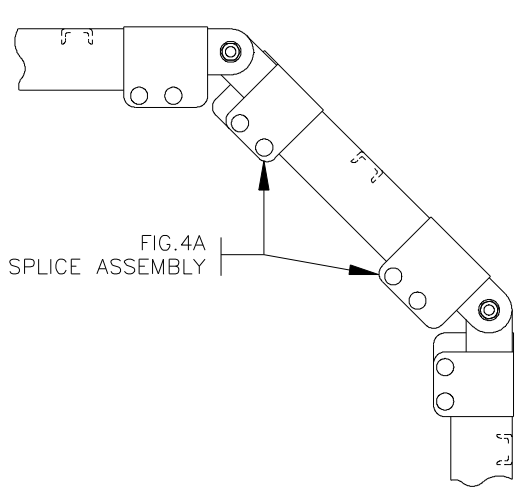

90 Degree Outside Turn
Radius More Than 6 Inches

Fig. 7A

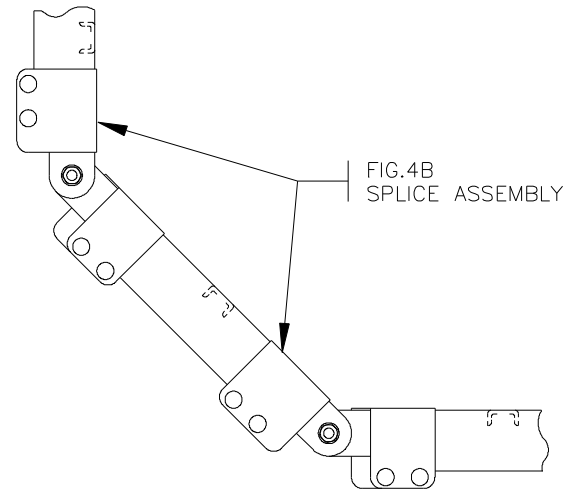

90 Degree Inside Turn
Radius More Than 6 Inches

Fig. 7B

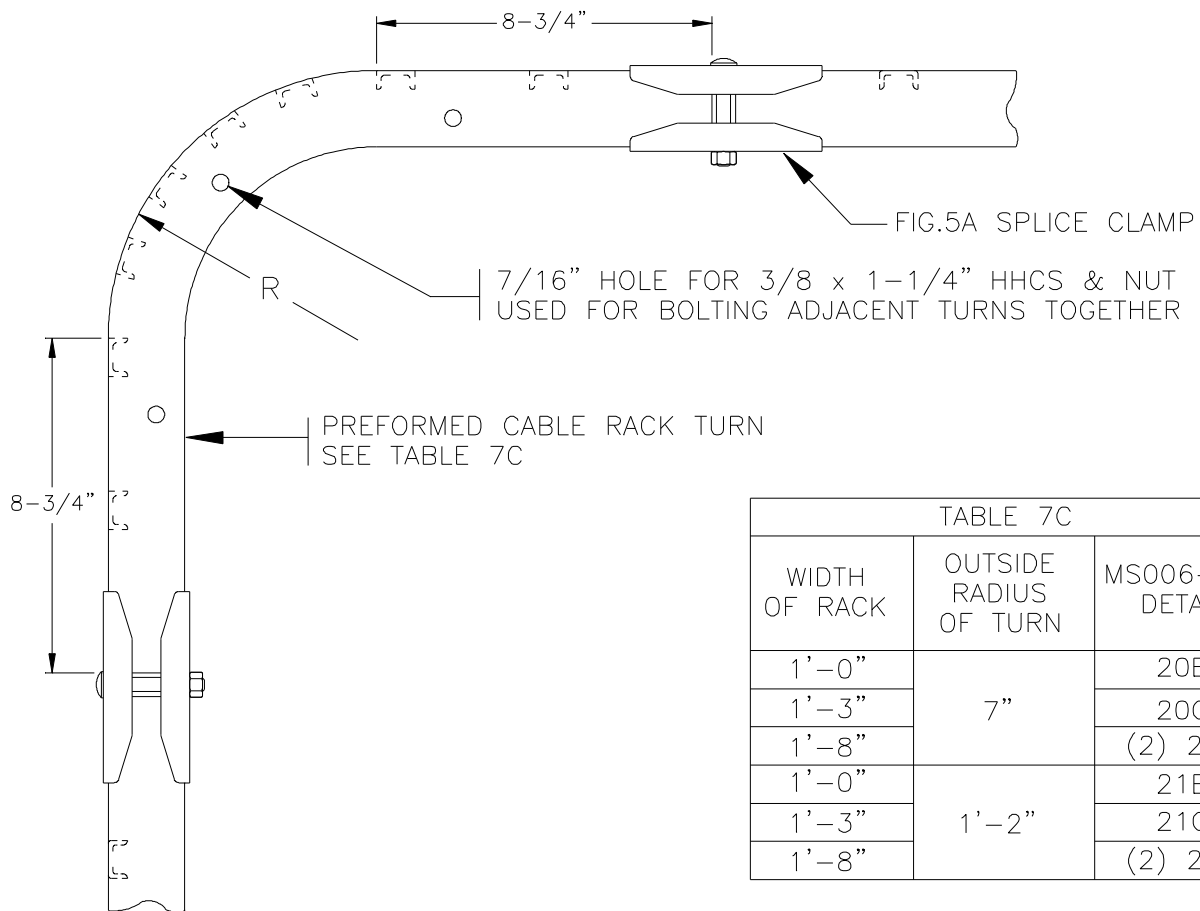
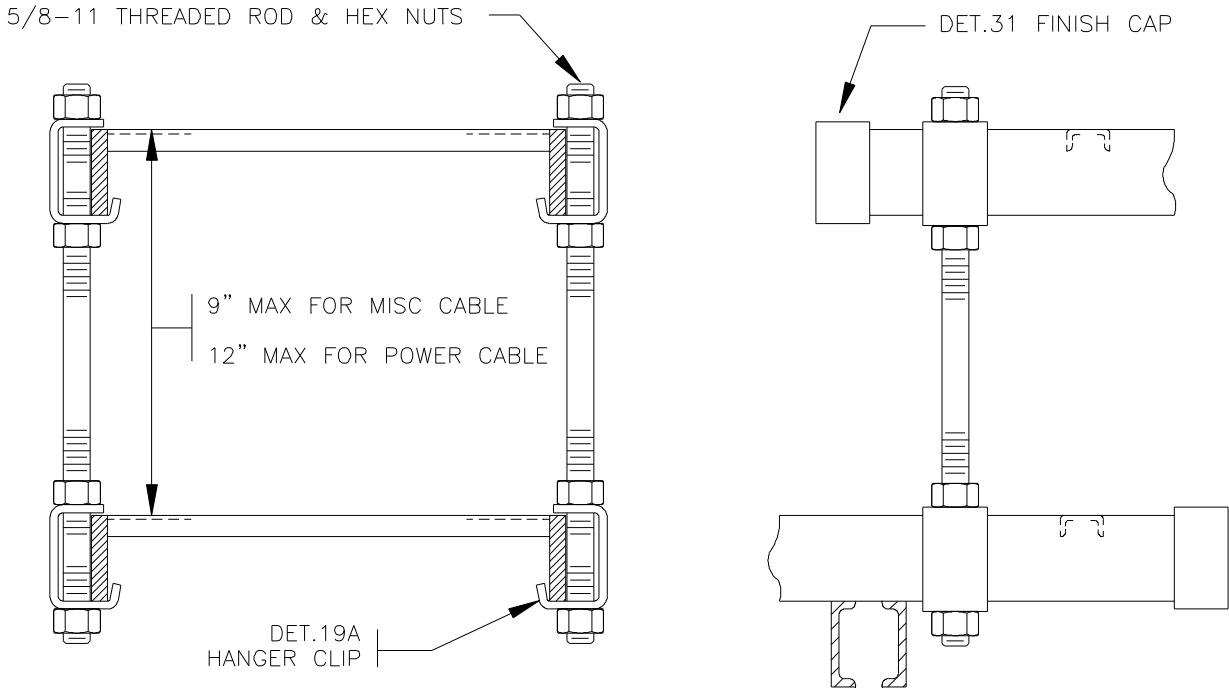

TABLE 7C		
WIDTH OF RACK	OUTSIDE RADIUS OF TURN	MS006-151 DETAIL
1'-0"	7"	20B
1'-3"		20C
1'-8"		(2) 20A
1'-0"	1'-2"	21B
1'-3"		21C
1'-8"		(2) 21A

90 Degree Outside Turn - Power Cable Racks
Fig. 7C



Small Vertical Offset In Horizontal Cable Racks

Fig. 8A

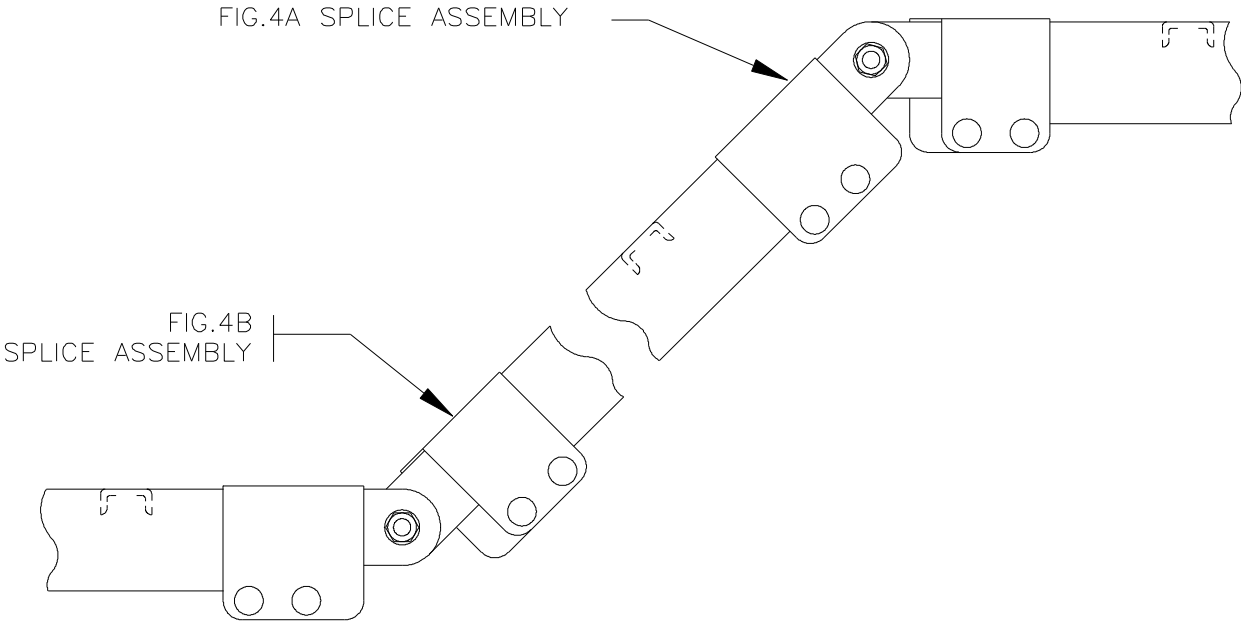

Large Vertical Offset In Horizontal Cable Racks (Offset More Than 9 Inches)

Fig. 8B

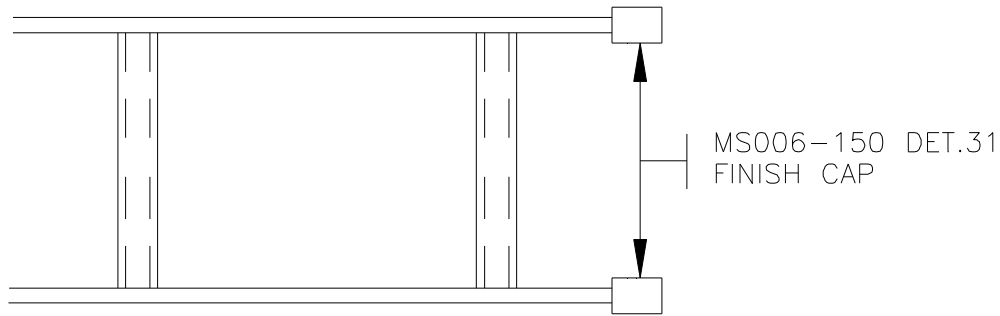

Terminating Exposed Ends Of Cable Racks

Fig. 9A

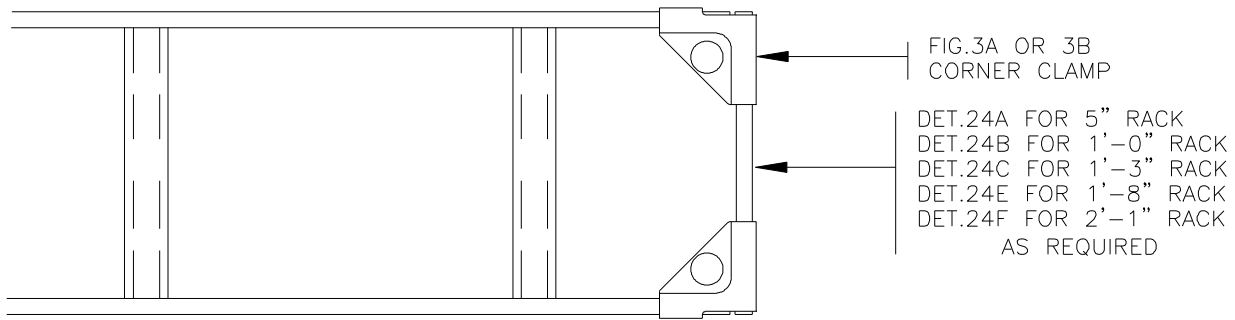

Terminating Exposed Ends Of Cable Rack Where Cable Continues

Fig. 9B

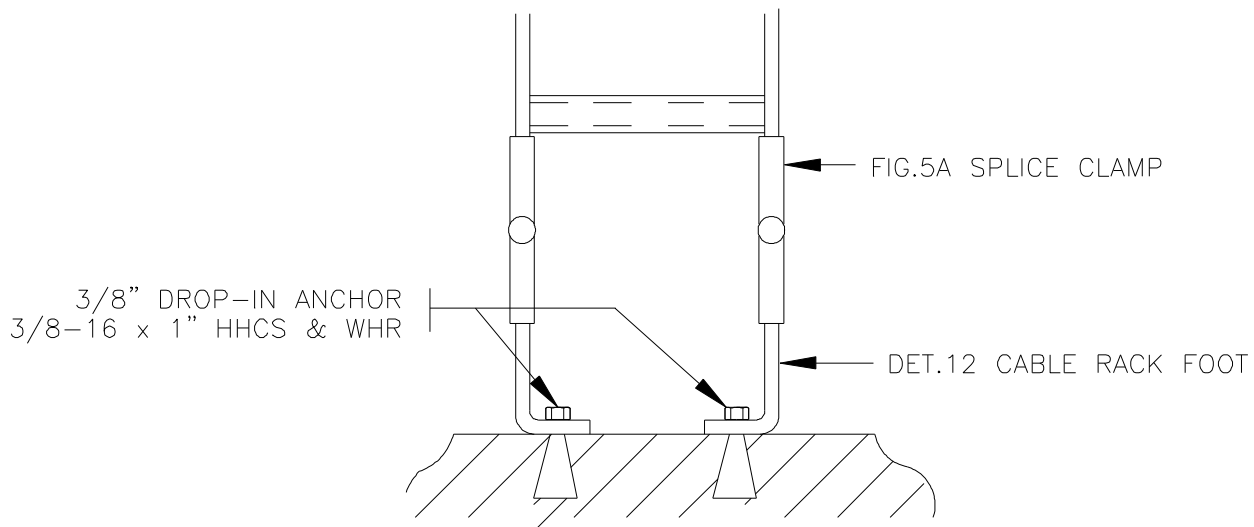

Terminating End Of Cable Rack At Concrete Floor

Fig. 9C

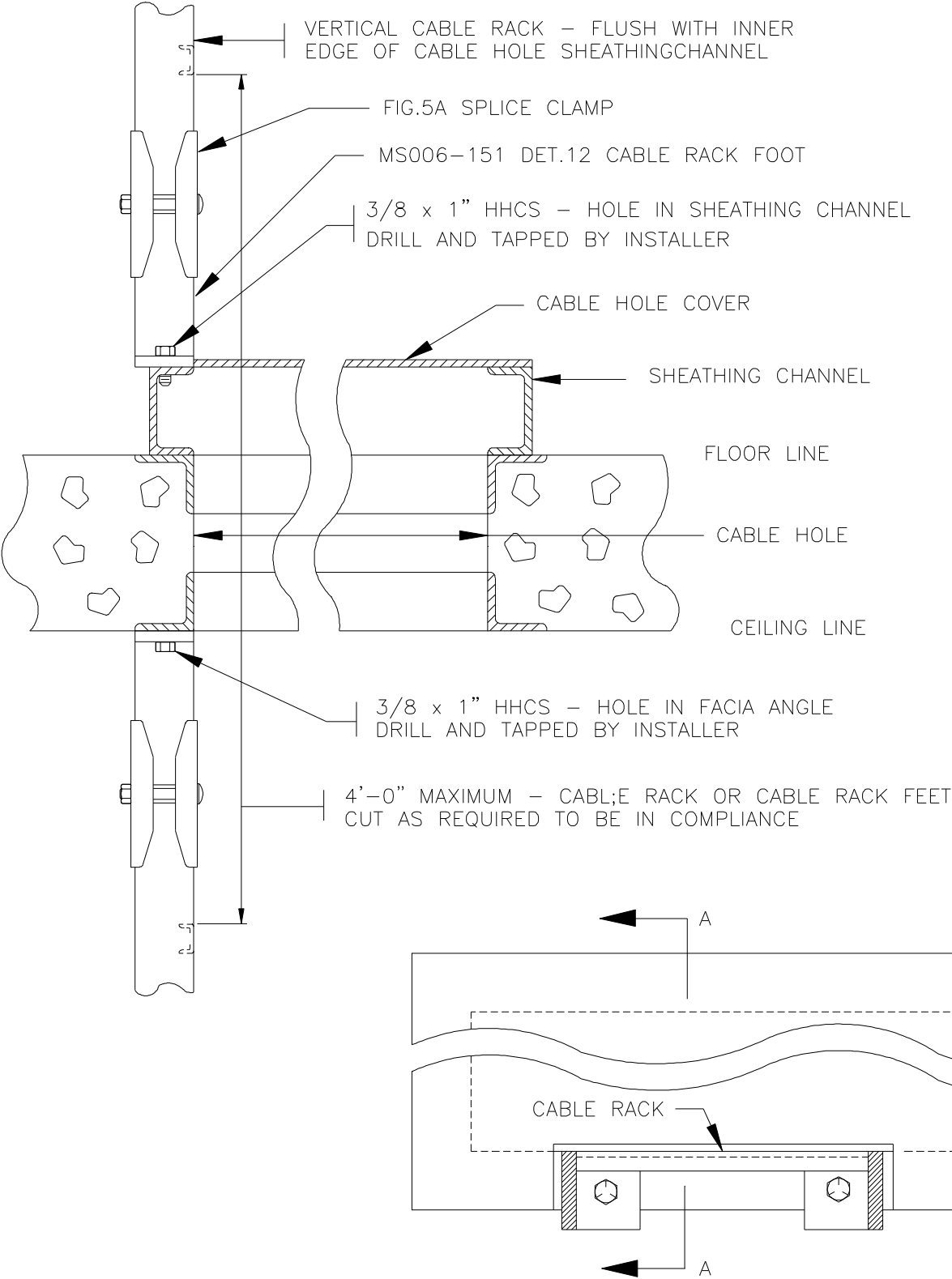

Terminating Vertical Cable Rack At Cable Holes

Fig. 9D

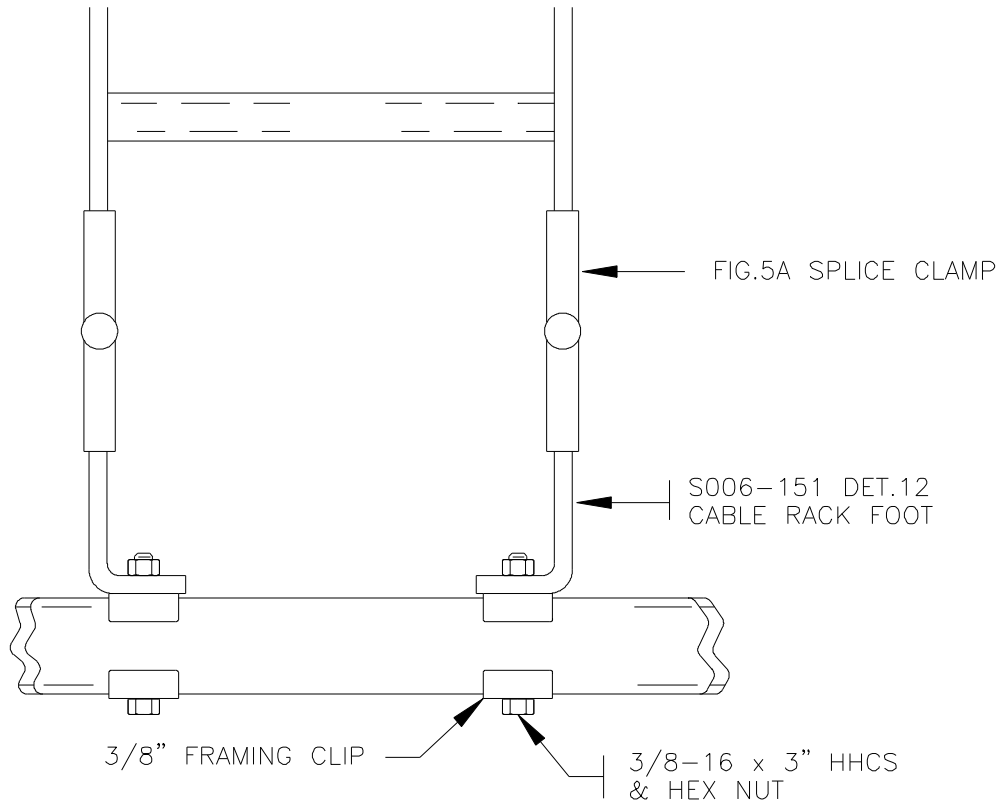

Terminating Cable Rack At Auxiliary Framing

Fig. 9E

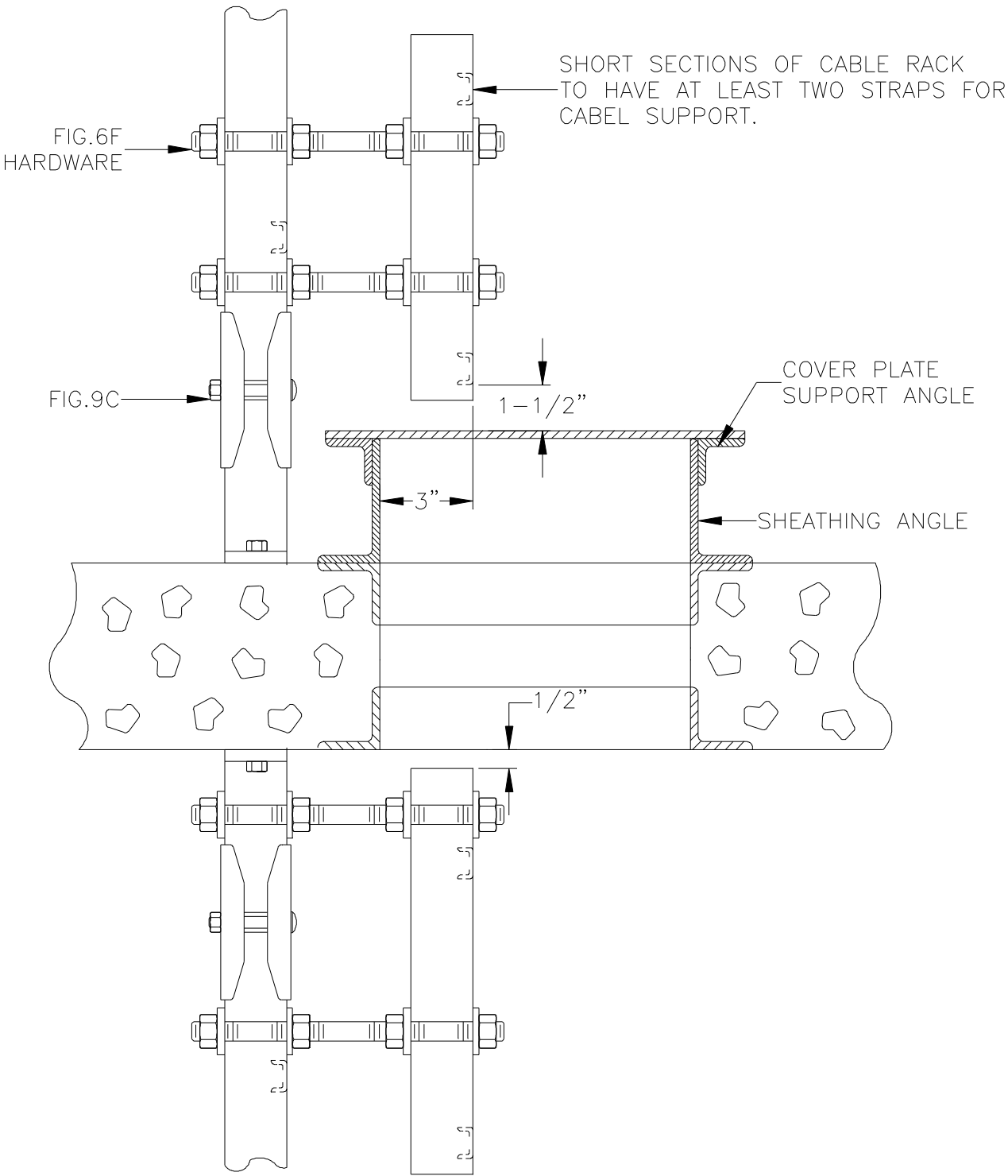

Terminating Vertical Cable Rack At Cable Hole – Angle Type Sheathing

Fig. 9F

1. 3'-5 LB. CHANNEL FASTENED TO SUPPORT STRUCTURE WITH 5/8" FASTENERS
2. ANGLES AND 3'-5 LB. CHANNELS FASTENED TOGETHER WITH 1/2" FASTENERS
3. STEEL COVER PLATES FASTENED WITH 1/4" FASTENERS ON 3 INCH CENTERS
4. 1'-0" MAXIMUM SPACING FOR STEEL COVER PLATE SUPPORTS
5. 4'-0" MAXIMUM DISTANCE BETWEEN CABLE SUPPORTS

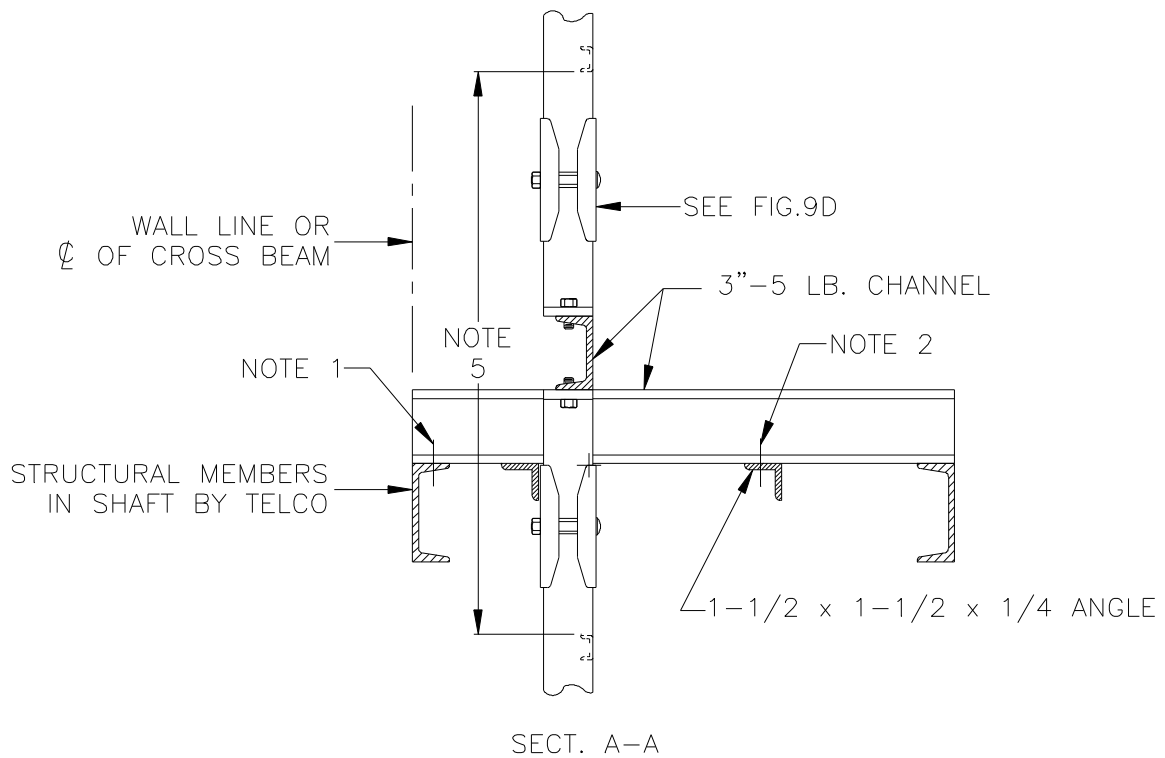
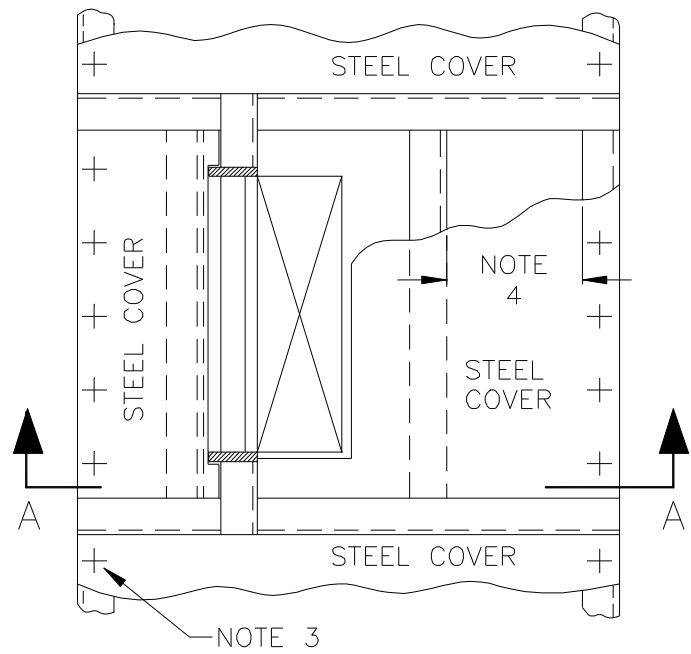

Typical Support of Vertical Cable Rack In Cable Shaft

Fig. 9G

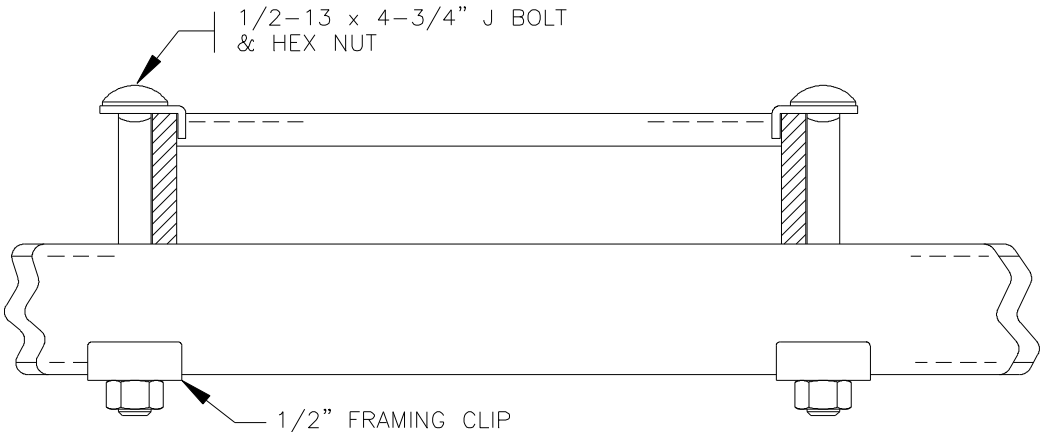

Cable Rack Support - Directly To Auxiliary Framing

Fig. 10A

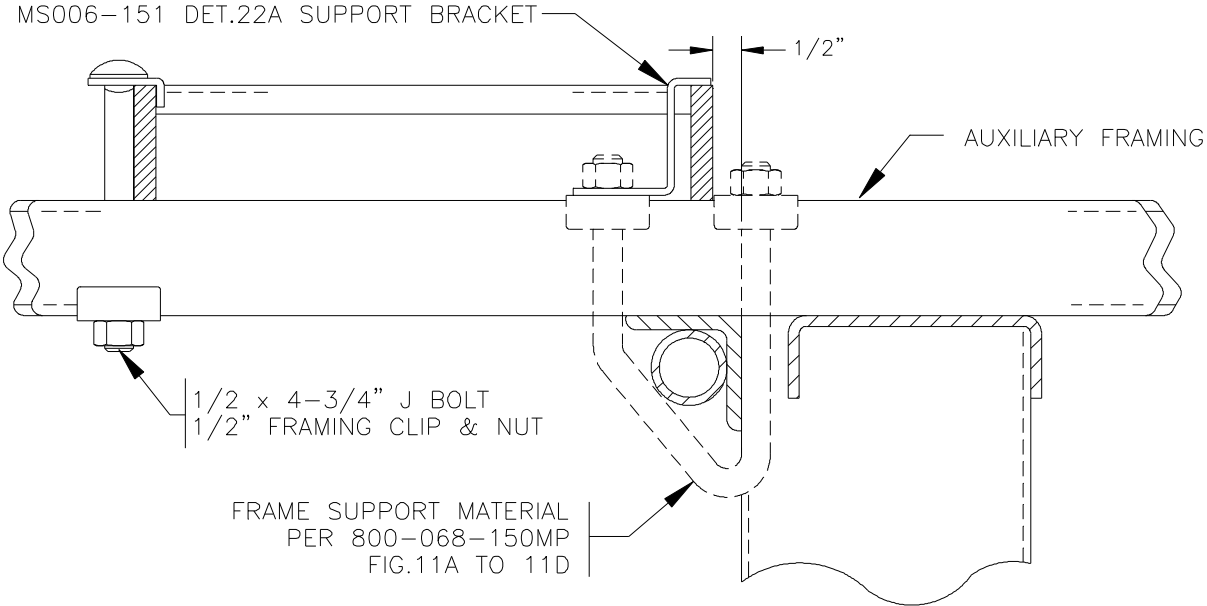

Cable Rack Support - Cable Rack Located 1/2 Inch From Duct Type Framework

Fig. 10B

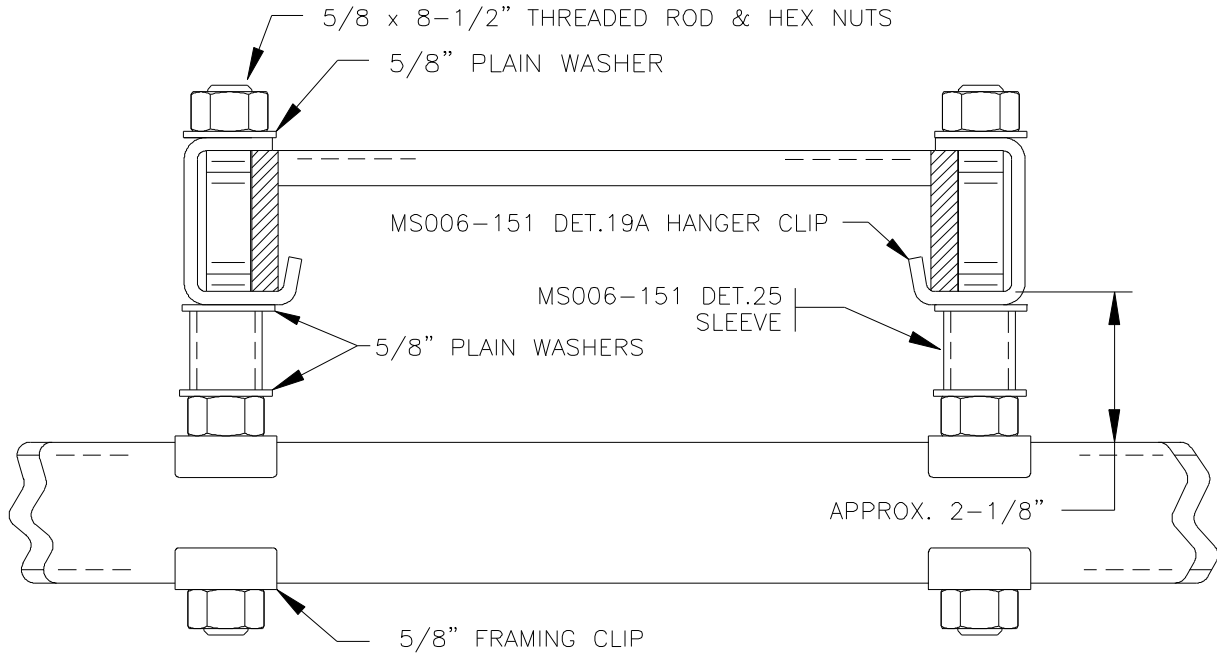

Cable Rack Support - Cable Rack Raised 2 Inches Above Auxiliary Framing

Fig. 10C

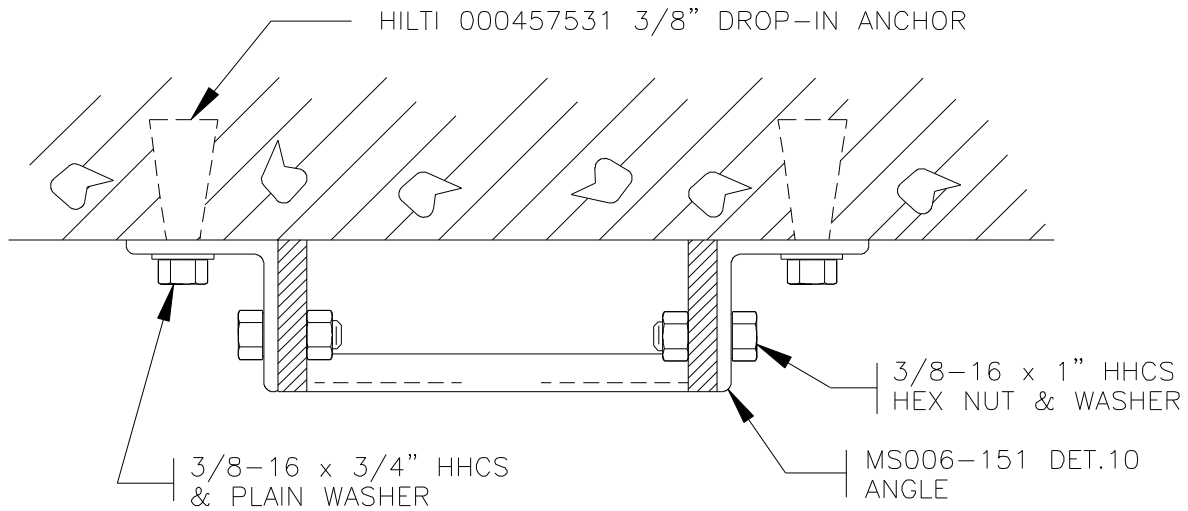

Cable Rack Support - Vertical Cable Rack To Concrete Wall Or Column

Fig. 10D

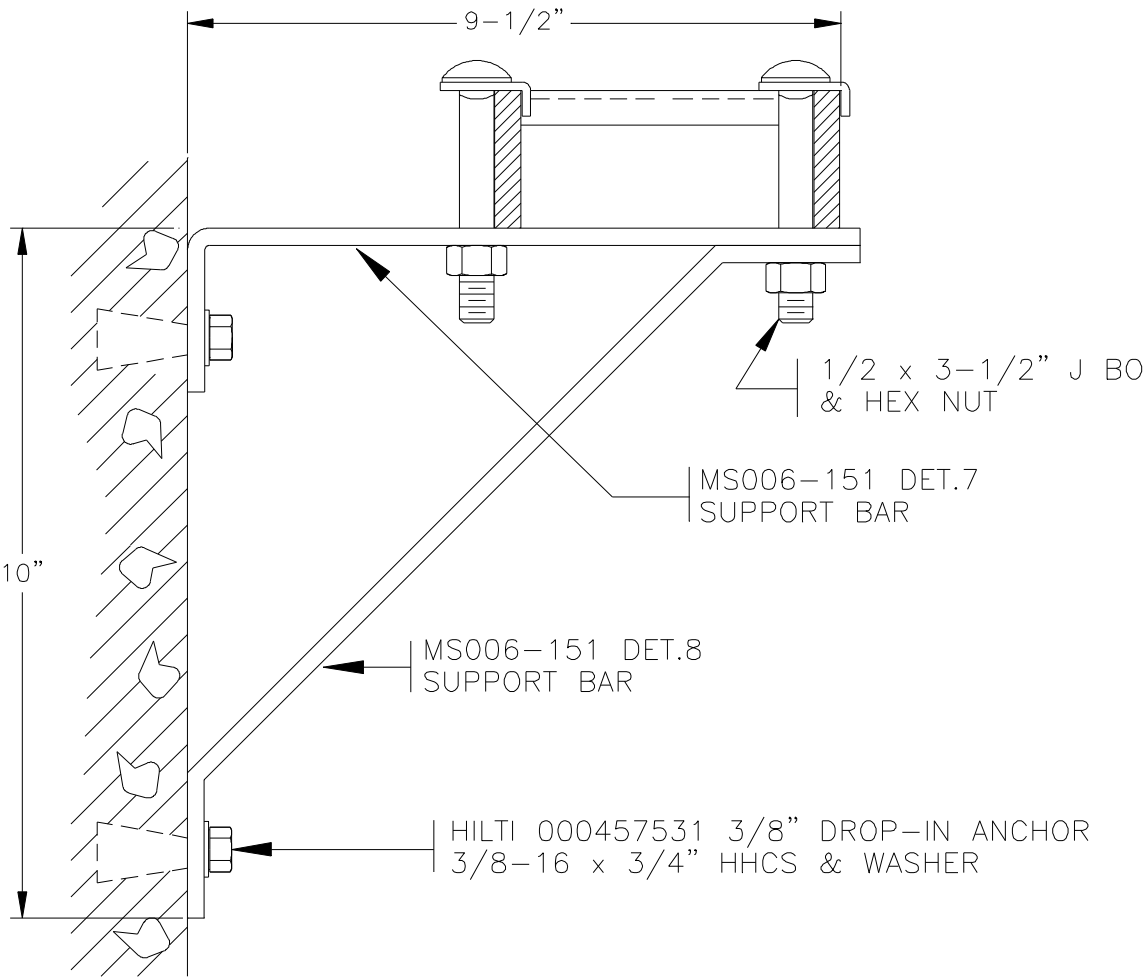

Cable Rack Support - Horizontal 5 Inch Rack To Concrete Wall Or Column

Fig. 10E

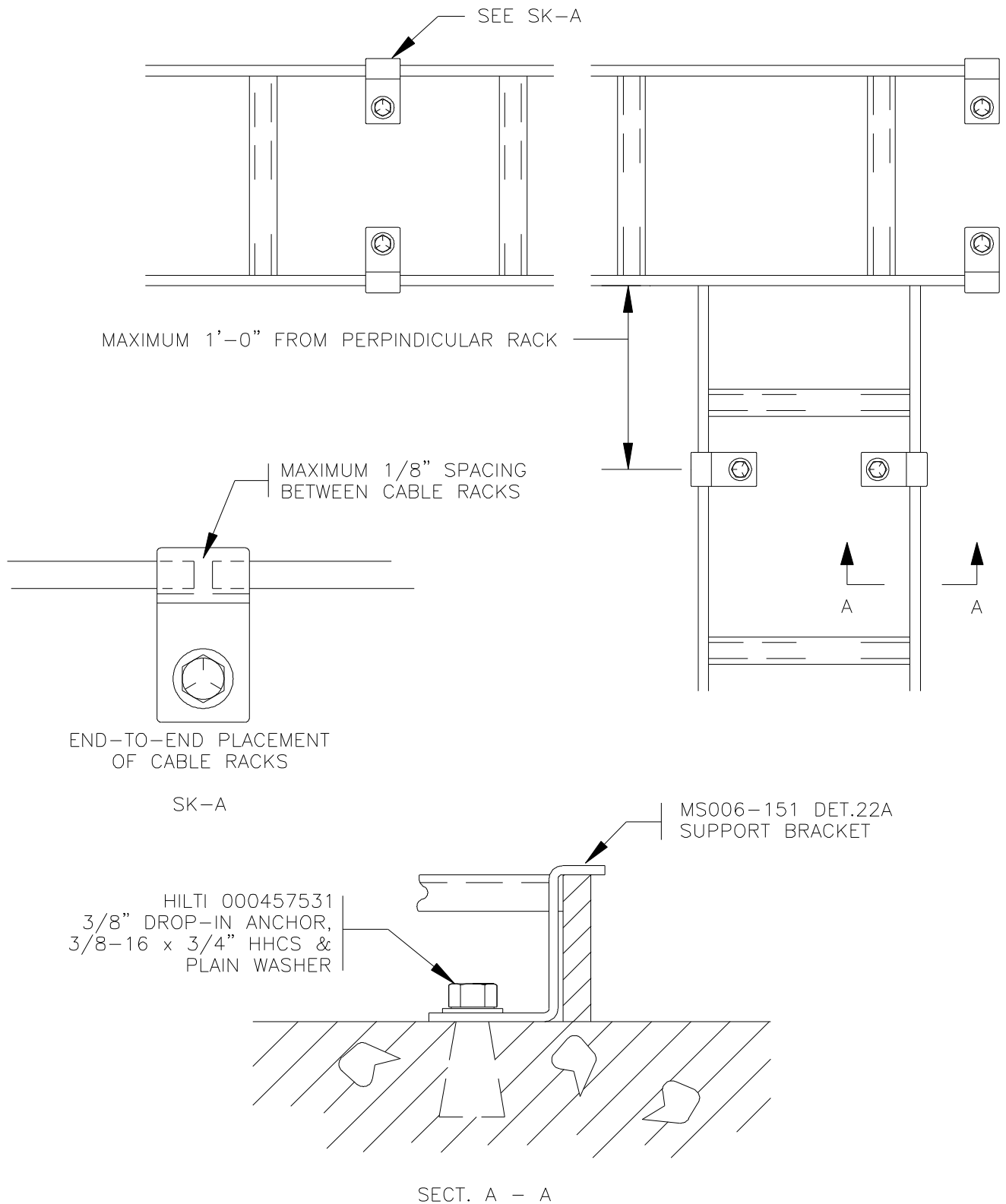

Cable Rack Support - Horizontal Racks On Concrete Floor

Fig. 10F

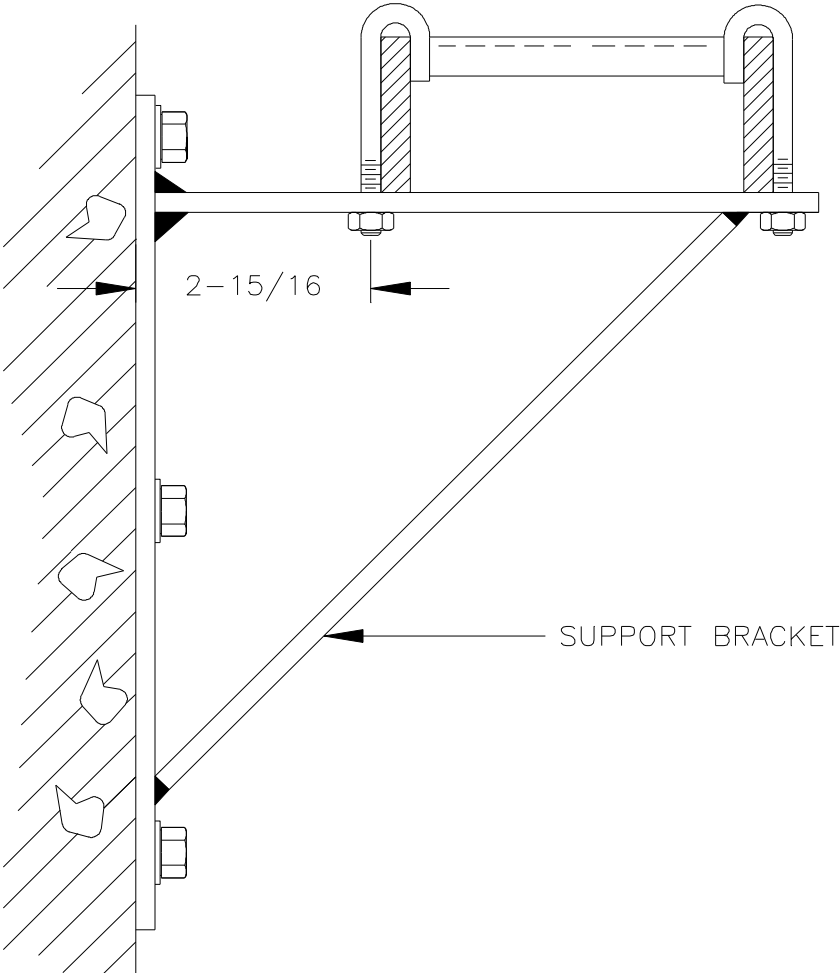

Cable Rack Size	Newton Part No.	
5 In.	Fig. 2065-C11	Kit Includes Support Bracket and Two 1/4-20 J Bolts
10 In.	Fig. 2065-C14	
12 In.	Fig. 2065-C16	

Not: Anchor Bolts Ordered Separately

Cable Rack Support Along Walls – Heavy cable loads – Newton Instrument Co.
 Fig. 10G

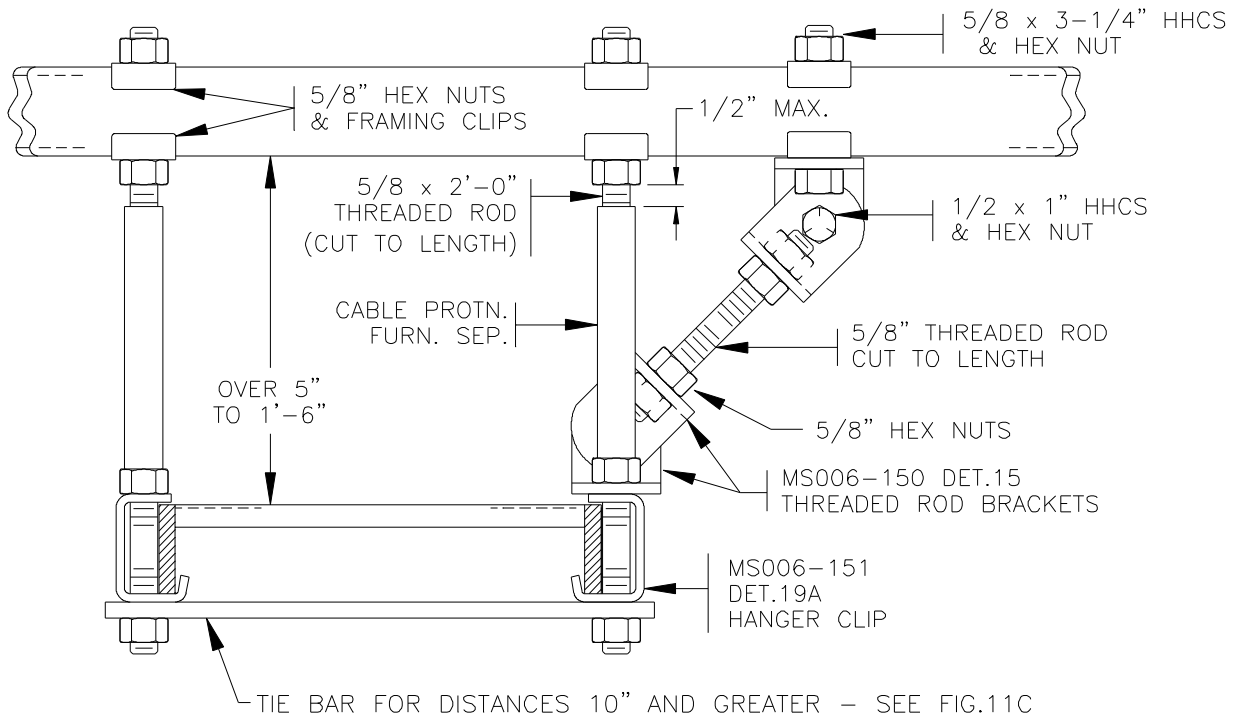

**Cable Rack Support And Bracing
Cable Rack Not Attached Directly To Auxiliary Framing**

Fig. 11A

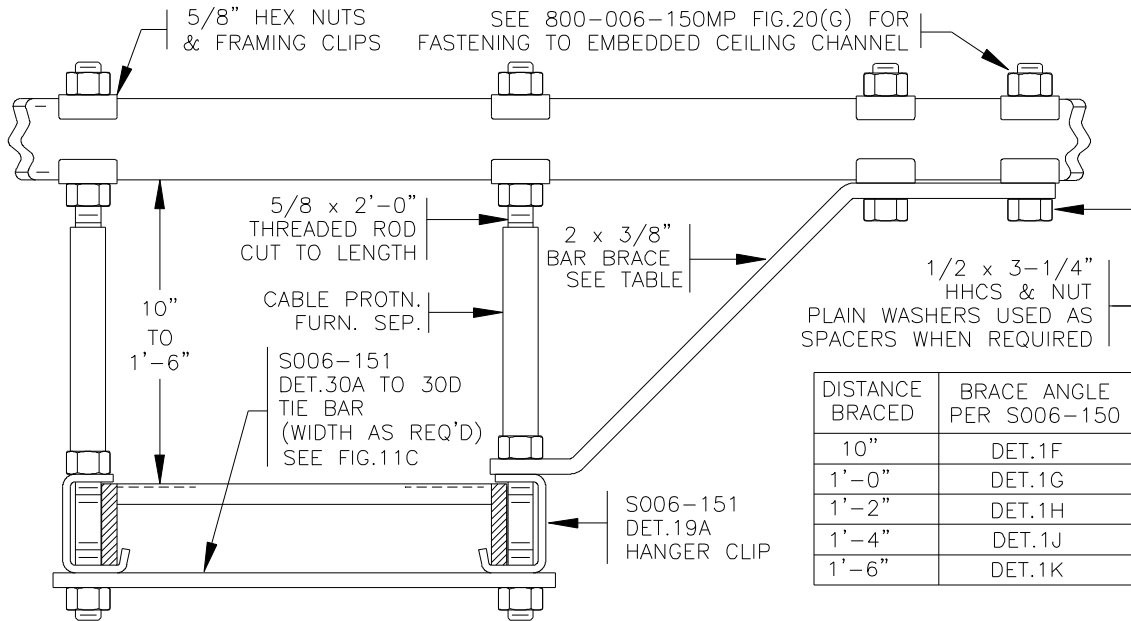

**Cable Rack Support And Bracing
Cable Rack Not Attached Directly To Auxiliary Framing
(Discontinued Practice- Replaced By Fig.11A - 11/99)**

Fig. 11B

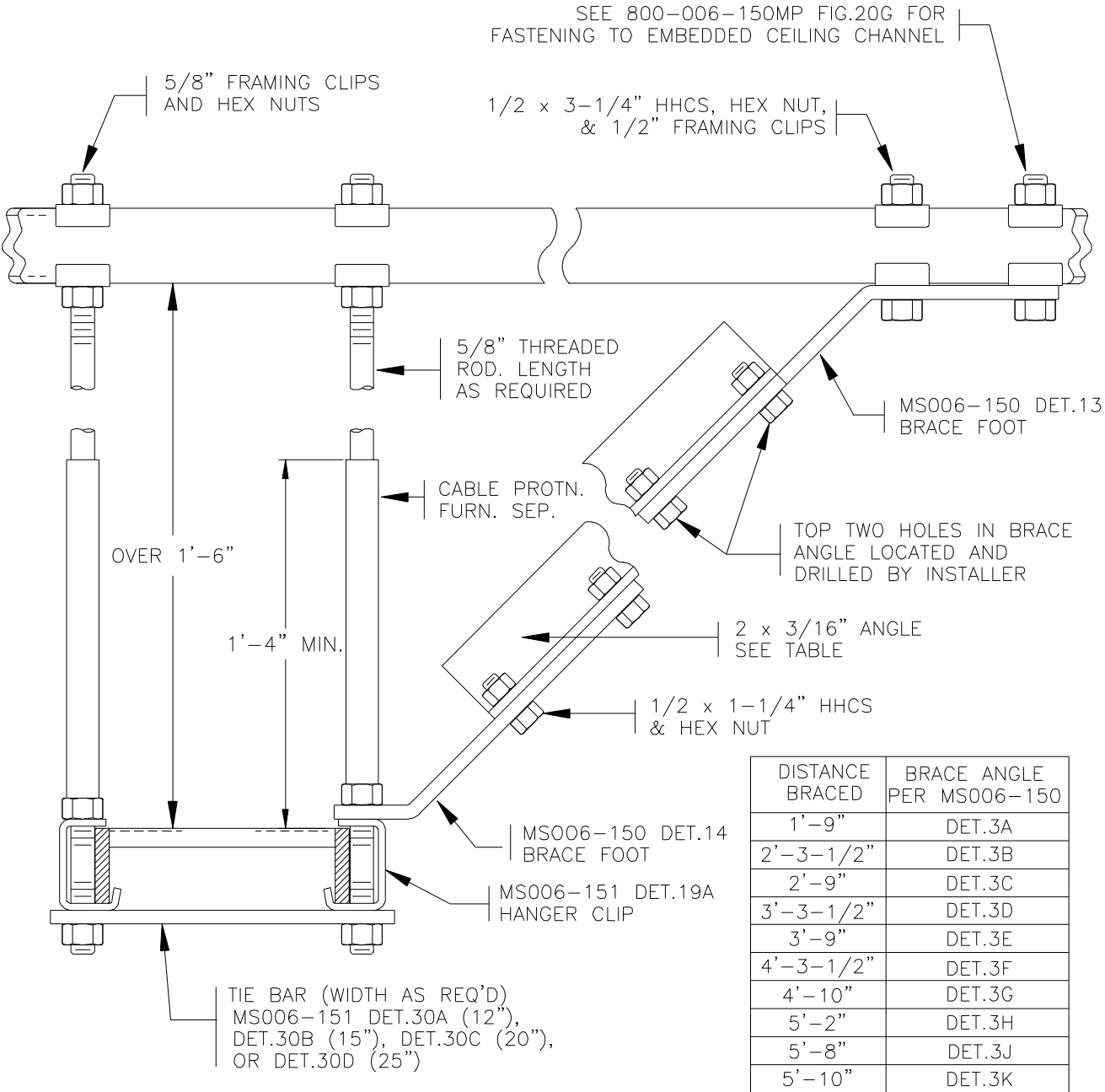

Cable Rack Support And Bracing
 Cable Rack Not Attached Directly To Auxiliary Framing
 Fig. 11C

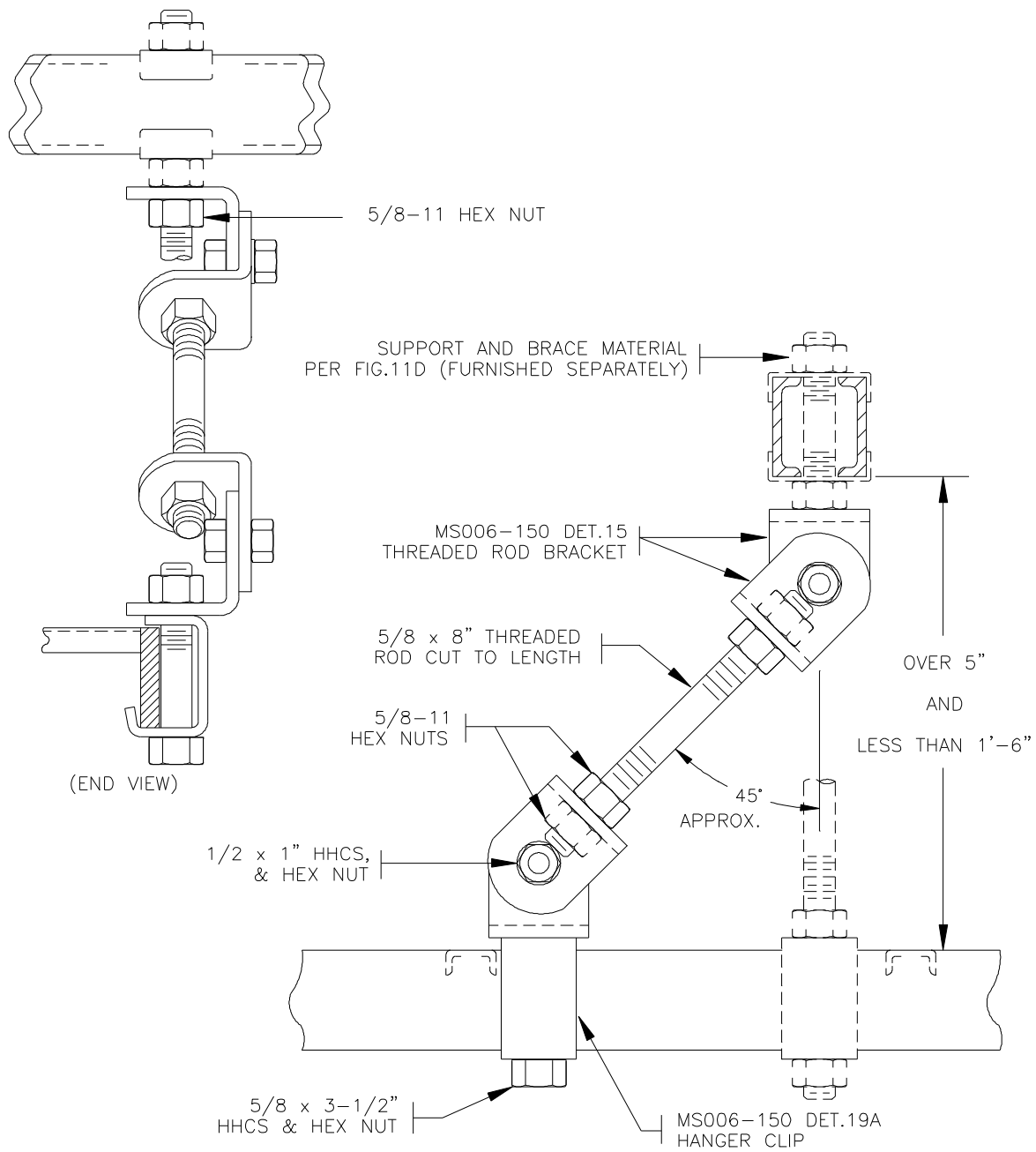

Cable Rack End Brace
Cable Rack Not Attached Directly To Auxiliary Framing
Fig. 11D

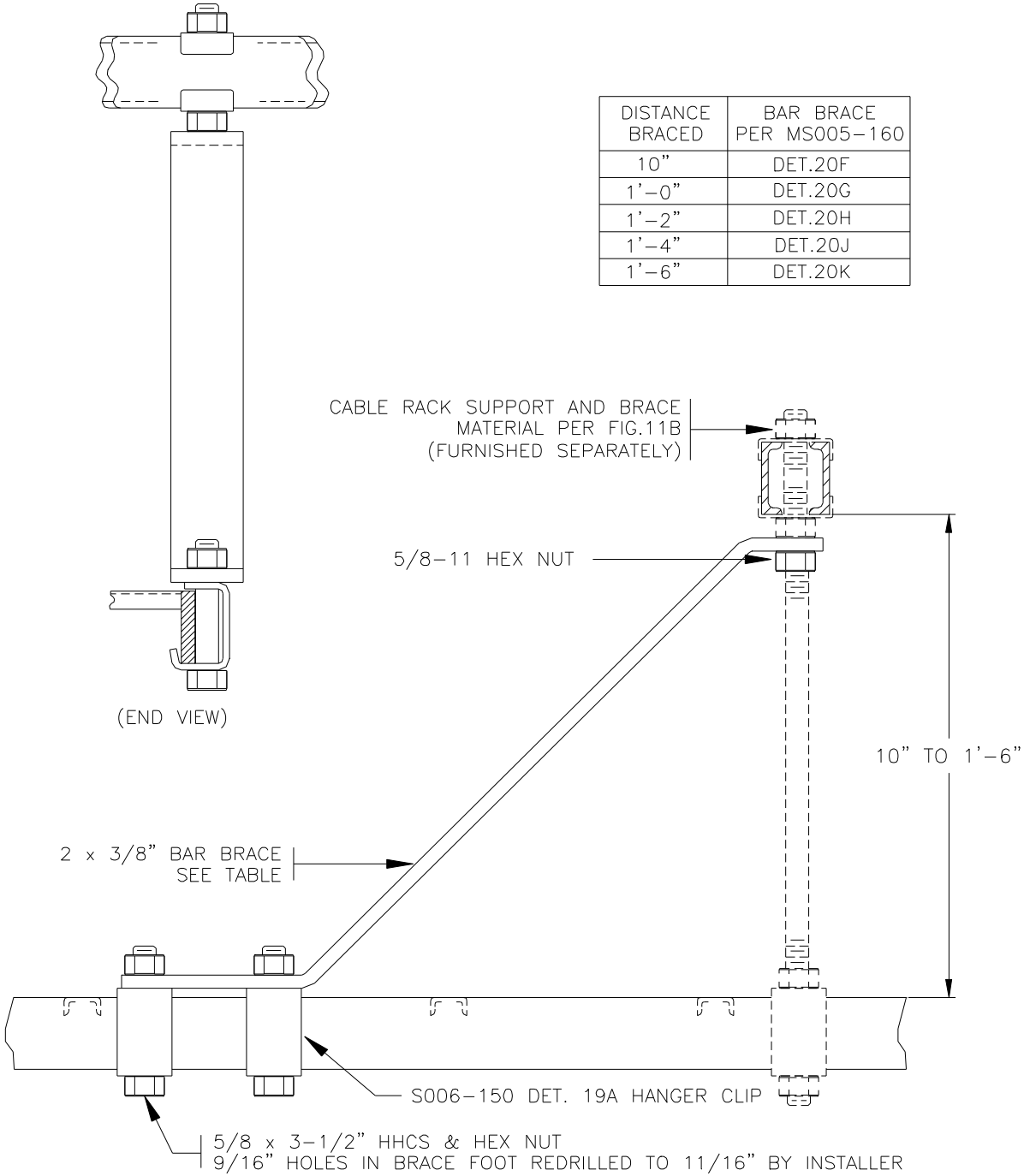

Cable Rack End Brace
Cable Rack Not Attached Directly To Auxiliary Framing
Fig. 11E
(Discontinued Practice- Replaced By Fig.11D - 11/99)

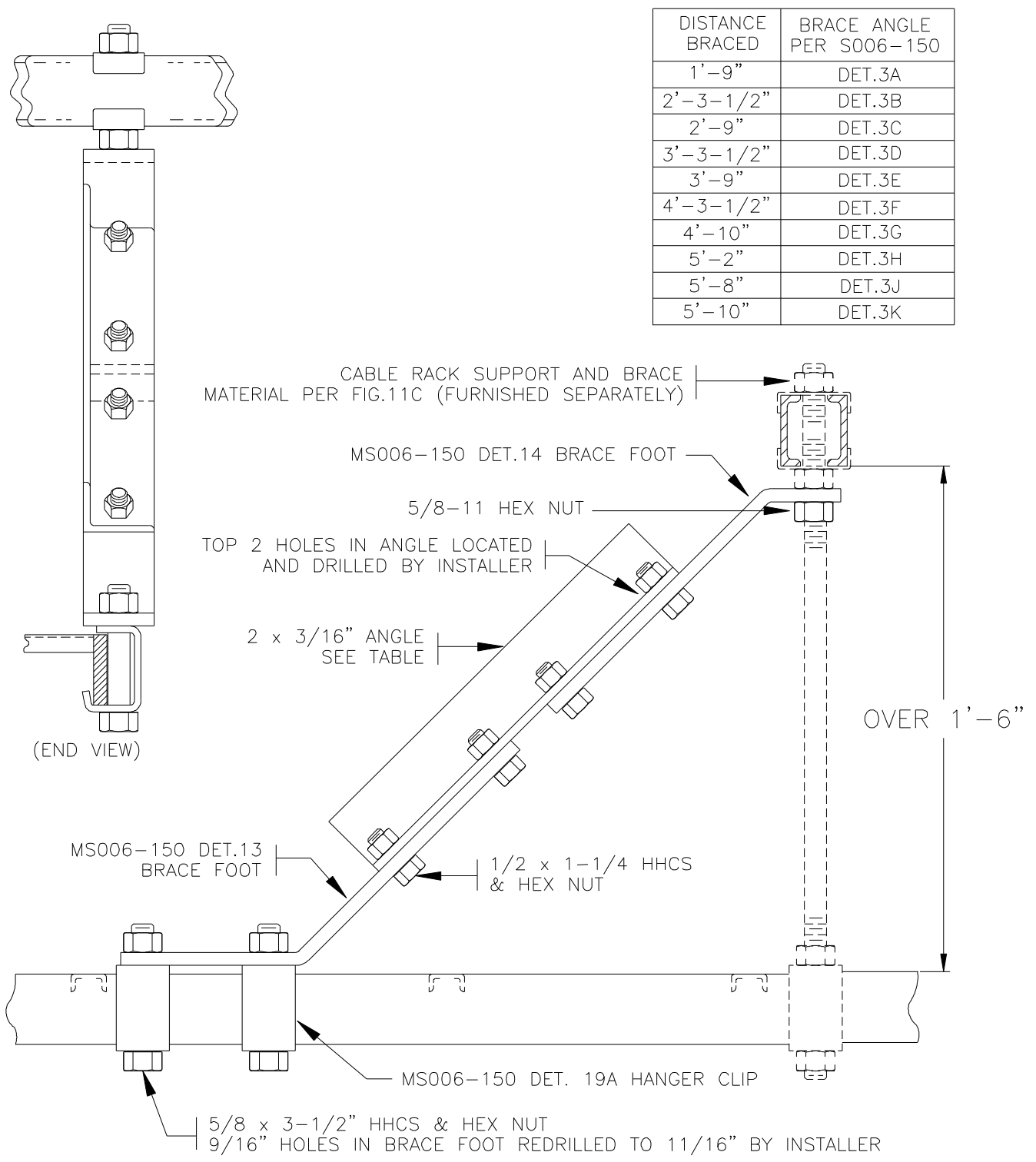

Cable Rack End Brace
Cable Rack Not Attached Directly To Auxiliary Framing

Fig. 11F

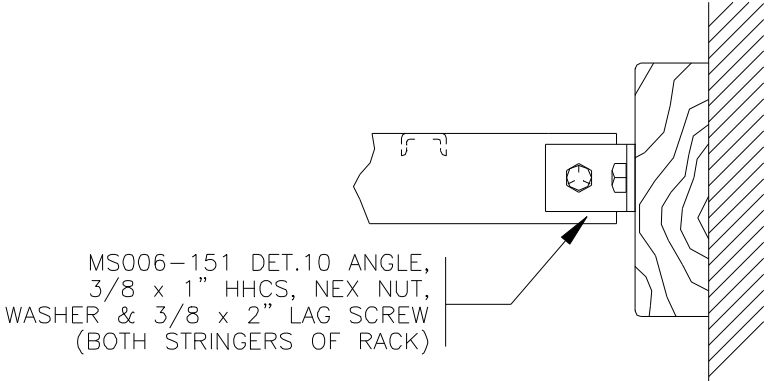

ATTACHING CABLE RACKS WIDER THAN 5" TO BUILDING WALLS
SKETCH 12-1

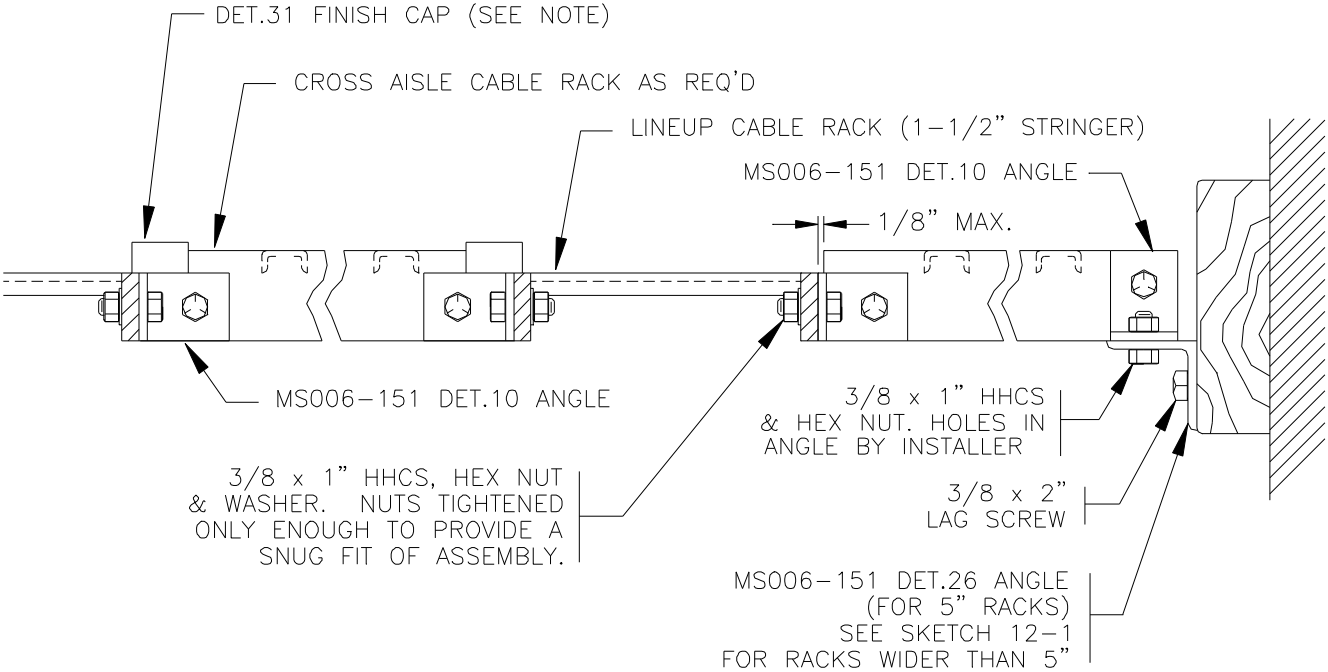

NOTE: FINISH CAPS ARE FURNISHED AS SEPARATE ITEM. CAPS ARE CUT TO FIT EXPOSED ENDS OF CABLE RACKS WHEN IN CLOSE PROXIMITY OF CABLE RUNS AND ARE TAPED IN PLACE.

Equipment Brace - CDO Type Offices
Bracing Equipment To Walls And Between Lineups

Fig. 12A

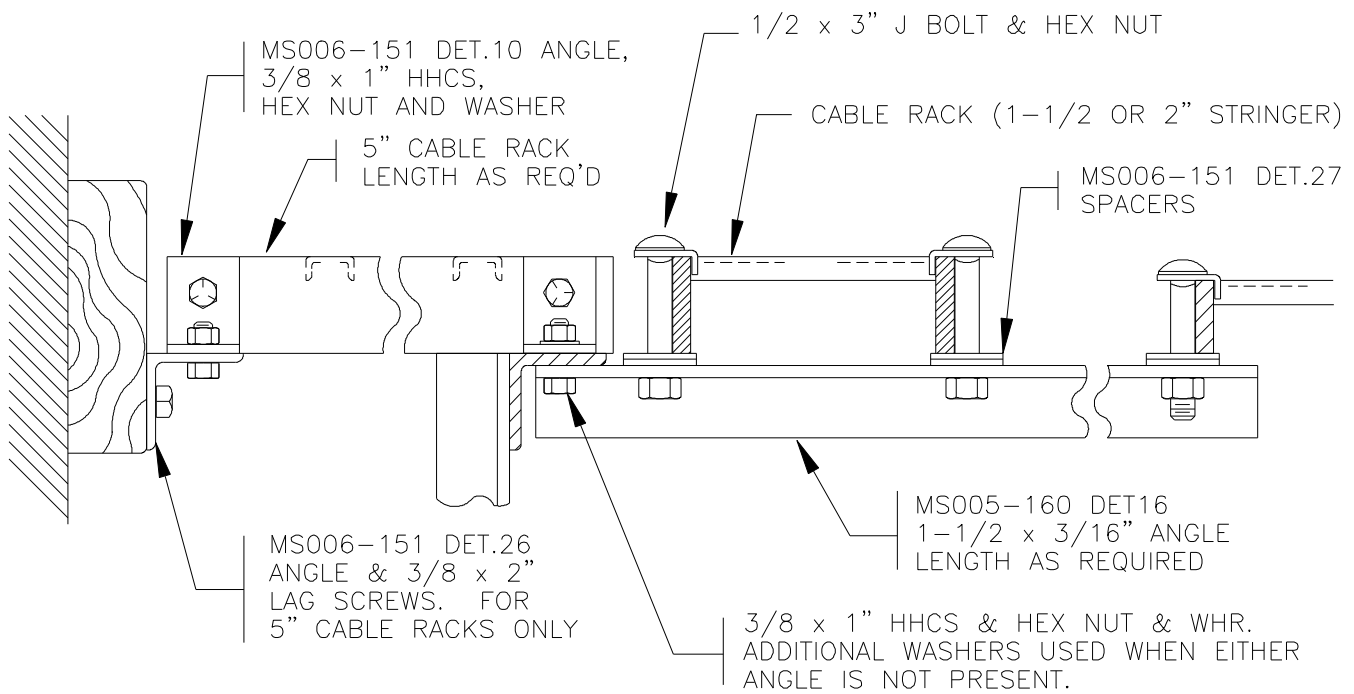

Equipment Bracing - CDO Type Offices
Bracing Distributing Frame To Wall And Between Equipment Lineups

Fig. 12B

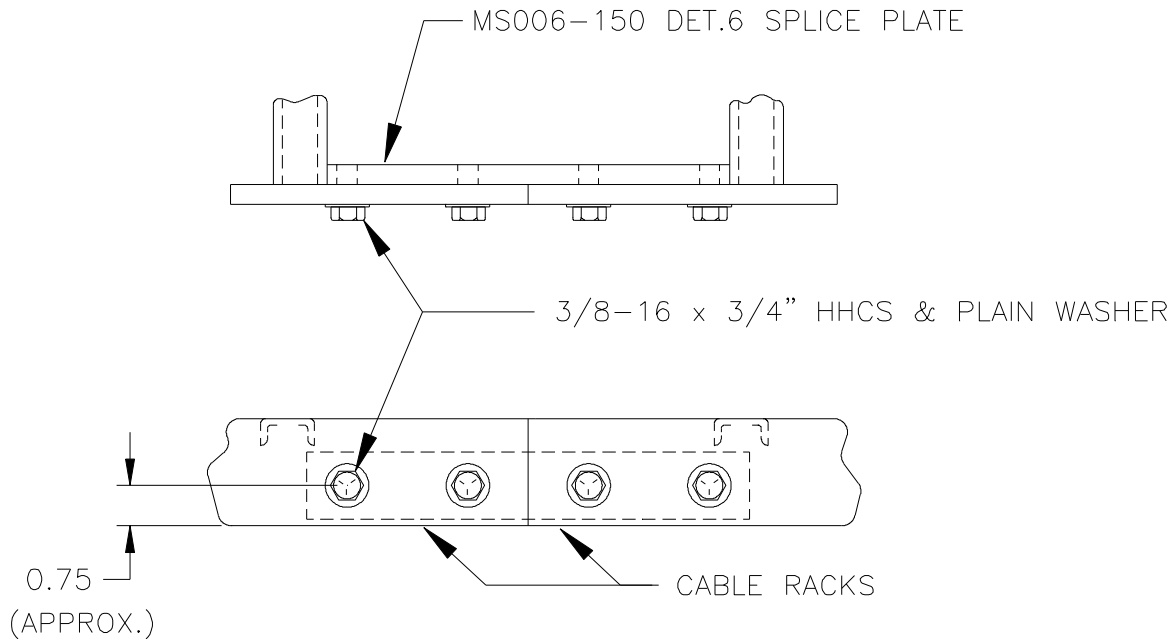

Cable Rack Splice - CDO Type Offices

Fig. 13

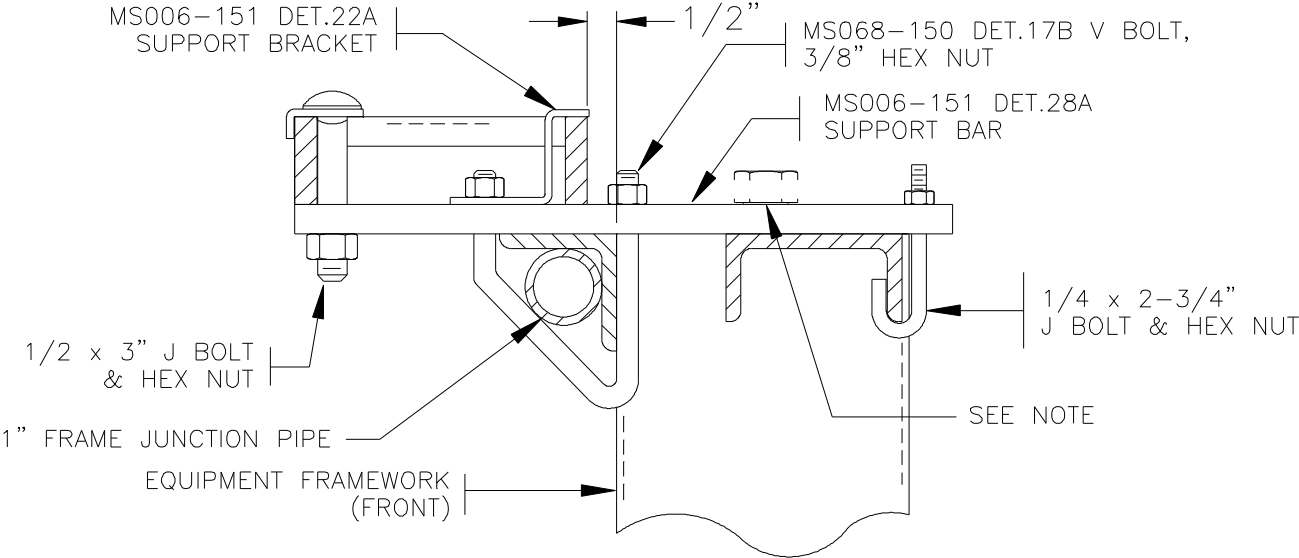

NOTE: 5/8 x 2" HHCS & PLAIN WASHER USED IN PLACE OF 1/4" J BOLT FOR PBSD-ED-6801 AND HENDRY HMW 12300 SERIES FRAMEWORKS.

5 Inch Cable Rack Support - CDO Type Offices
Cable Rack Located 1/2 Inch From Upright Of Duct Type Equipment Framework

Fig. 14A

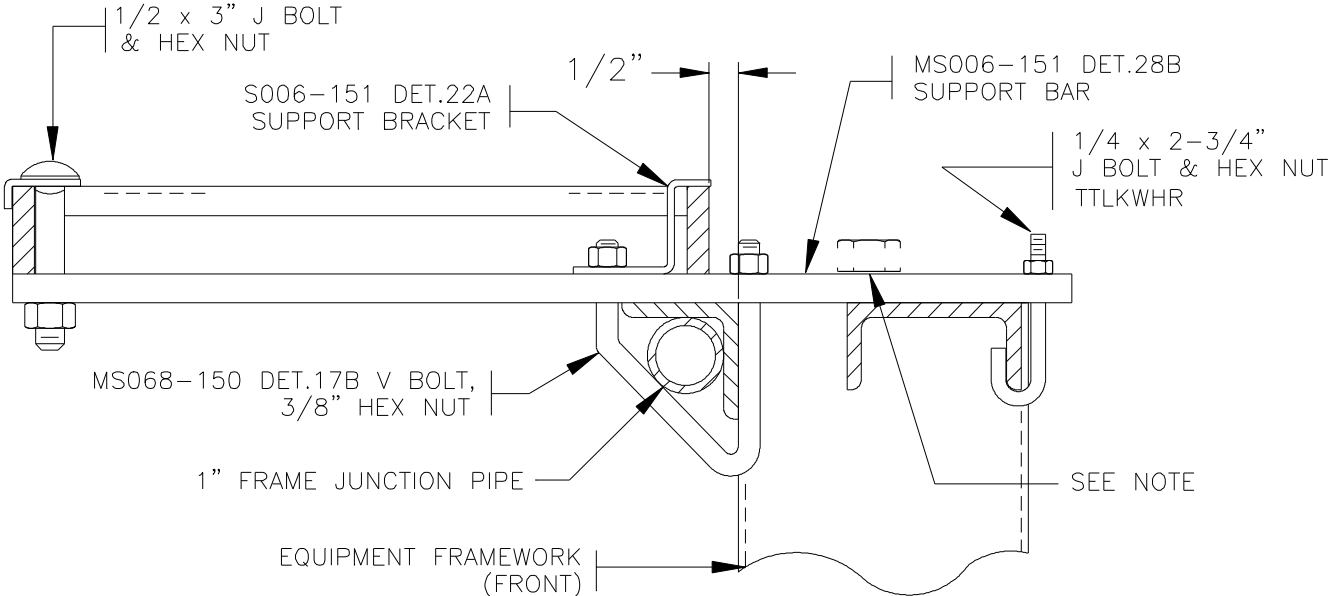

NOTE: 5/8 x 2" HHCS & PLAIN WASHER USED IN PLACE OF 1/4" J BOLT FOR PBSD-ED-6801 AND HENDRY HMW 12300 SERIES FRAMEWORKS.

12 Inch Cable Rack Support - CDO Type Offices
Cable Rack Located 1/2 Inch From Upright Of Duct Type Equipment Framework

Fig. 14B

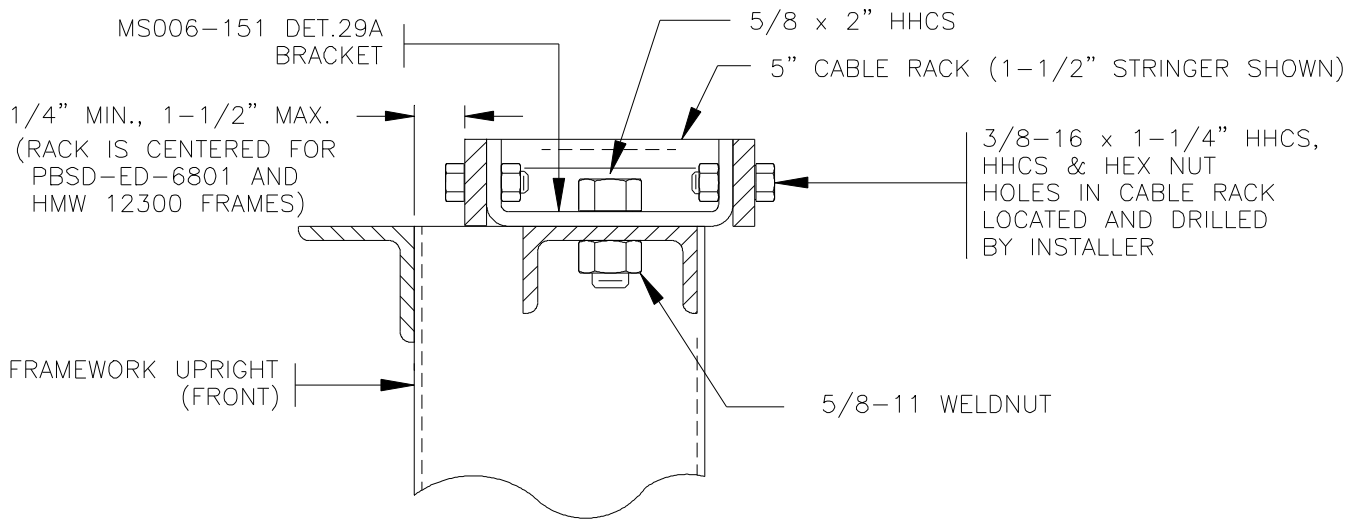

5 Inch Cable Rack Support - CDO Type Offices
Cable Rack Located Directly Above AT&T ED97170-50 Duct Type Equipment Framework Assembly

Fig. 15

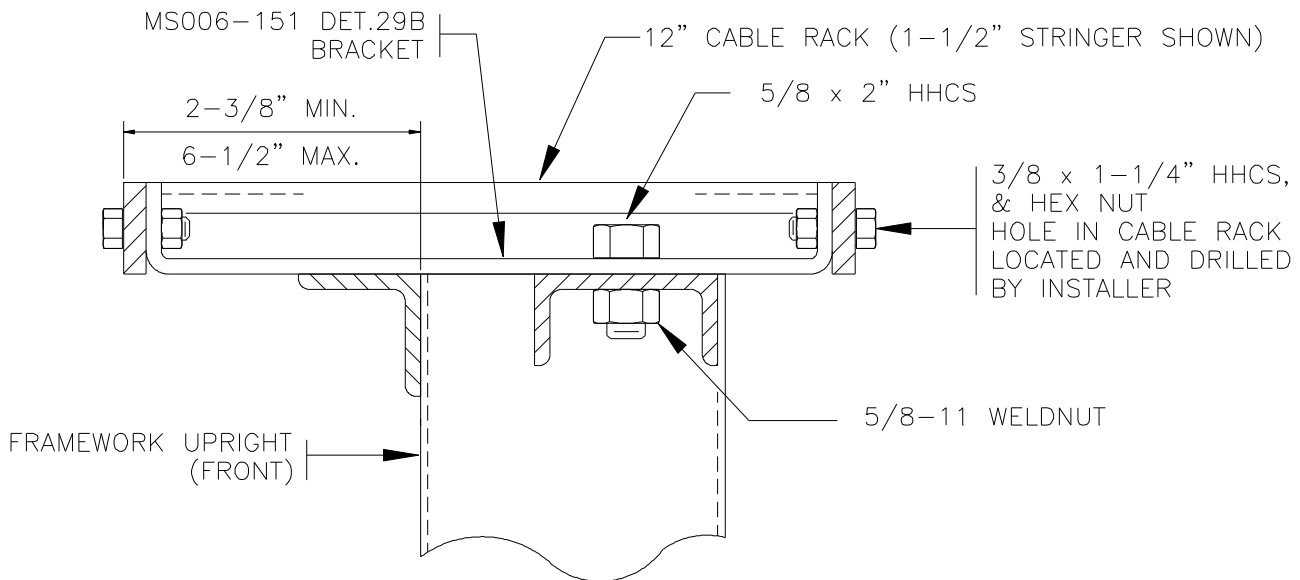

NOTE: MAXIMUM EXTENSION OF RACK TO FRONT OF PBSD-ED-6801 AND HMW 12300 FRAMES IS 7-1/2".

12 Inch Cable Rack Support - CDO Type Offices
Cable Rack Located Directly Above AT&T ED97170-50 Duct Type Equipment Framework Assembly

Fig. 16

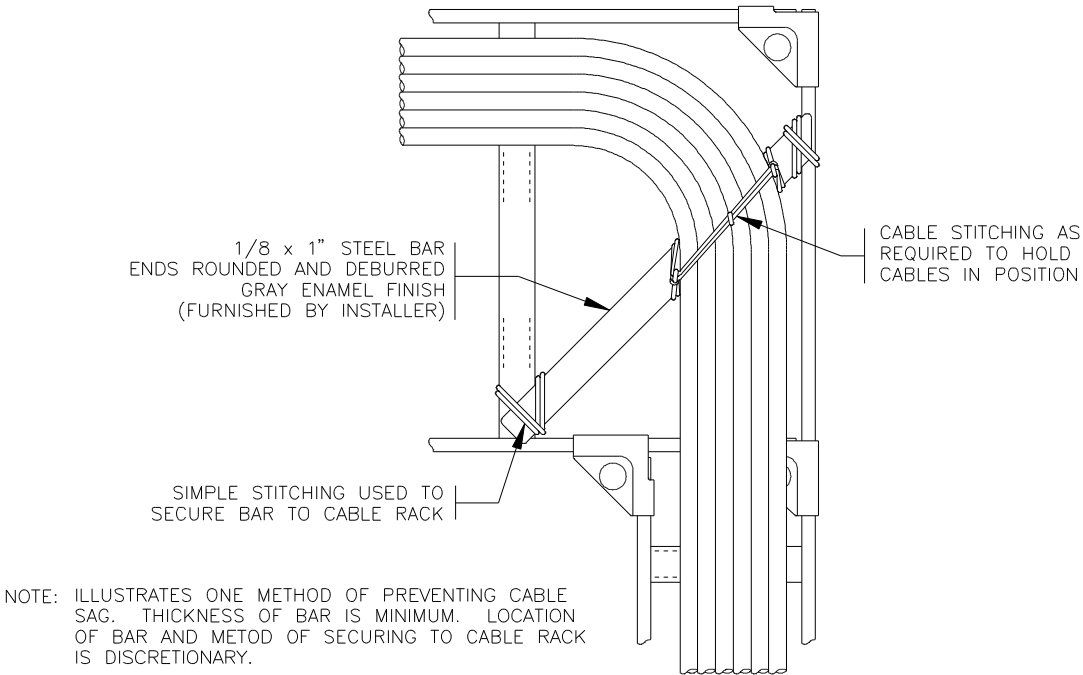

Additional Cable Support To Prevent Cable Sag

Fig 17

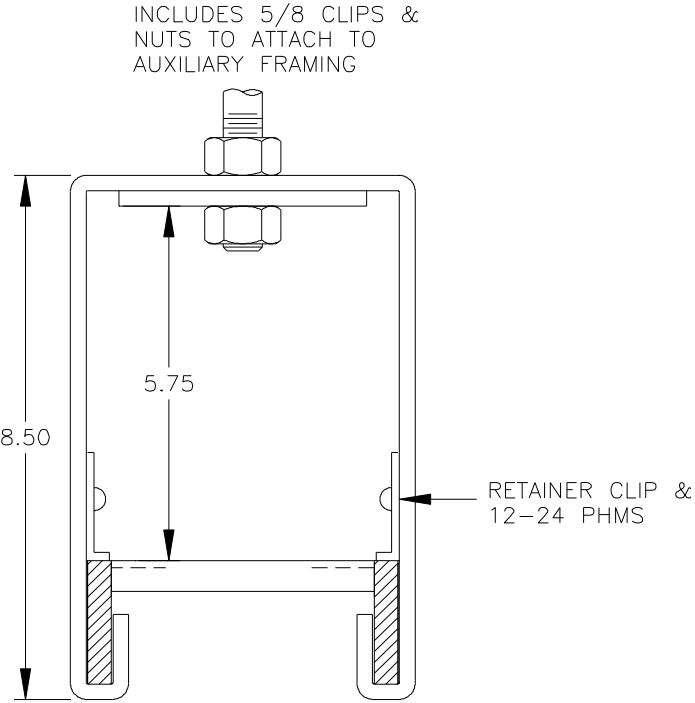

Part #NC-G1535-03 (Gray)

Part #NC-G1535-03-Y (Yellow)

5-Inch Cable Rack Support From Auxiliary Framing – NorCal Metal Fabricators

Fig 18

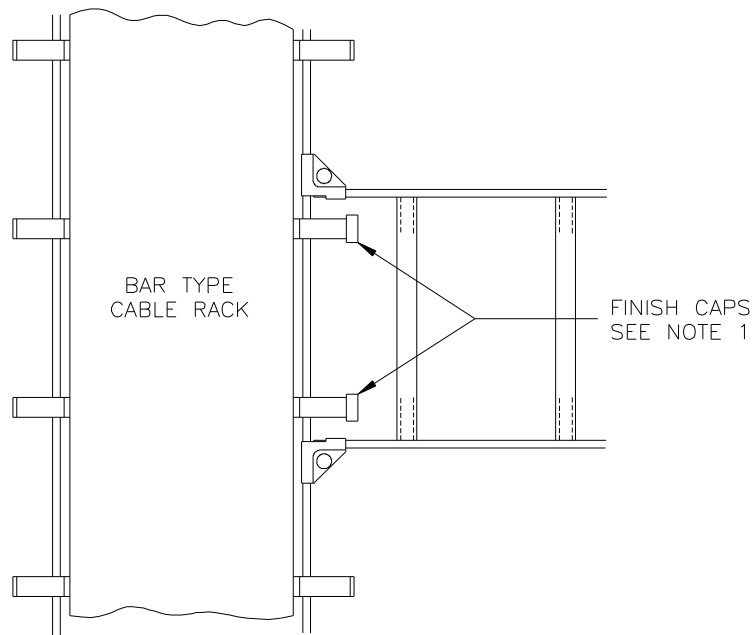

NOTE 1. VERTICAL PORTION OF CABLE RETAINER TO BE REMOVED

Tee Intersection Bar Type and Ladder Type Cable Rack

Fig. 19

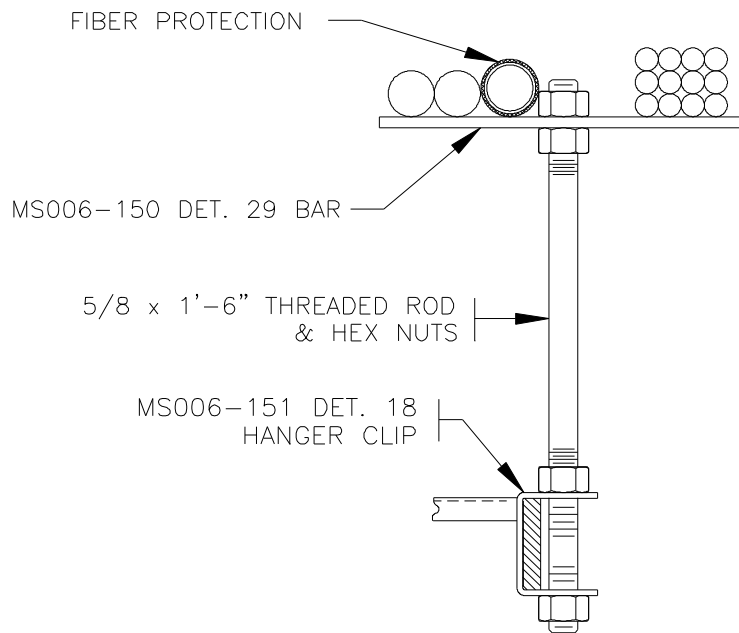

Auxiliary Cable Support For Cable Racks

Fig. 20

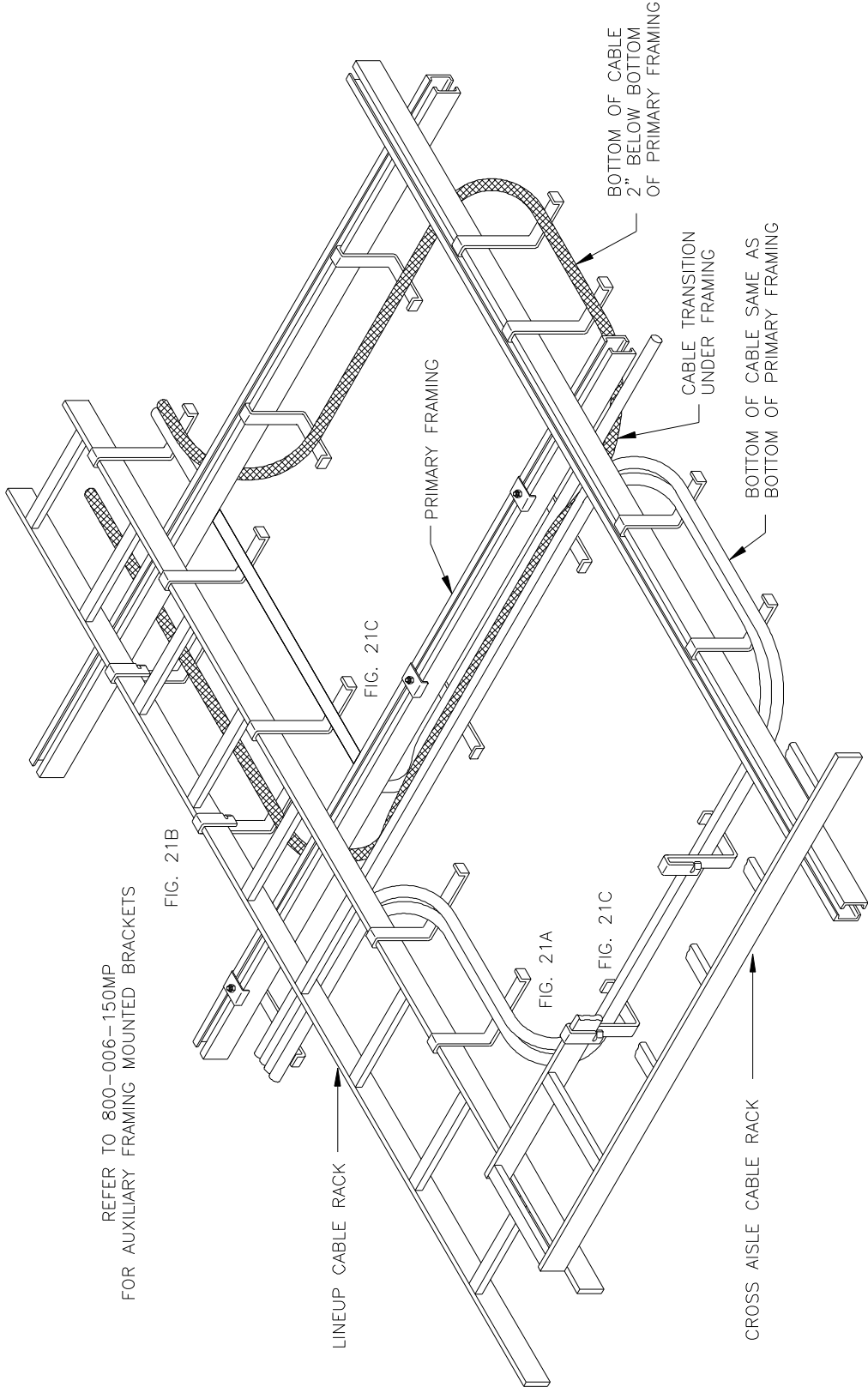

Fig. 21 – Typical Application Of Miscellaneous Cable Supports

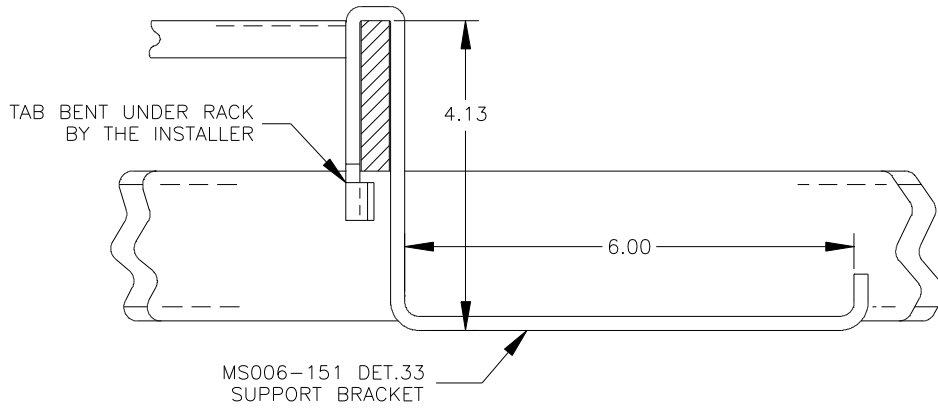

Fig. 21A

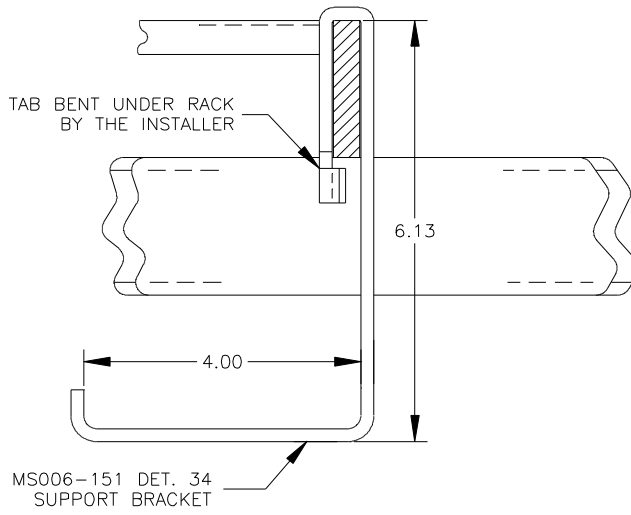

Fig. 21B

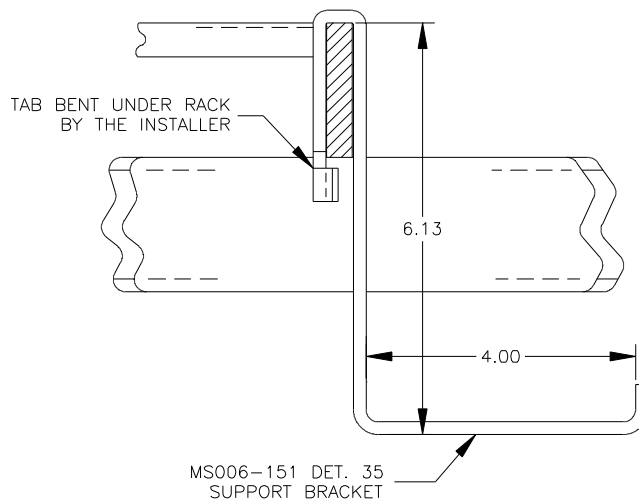

Fig. 21C