

BOOTHS — OUTDOOR

KS-14611 AND NO. 9

MAINTENANCE

1.00 BOOTH CHECK POINTS

- Safe approach to booth (refer dangerous conditions to agent and supervisor).
- Appearance of booth (see 2.00).
- Door operation (see 3.00).
- Panel and sign (see 5.00).
- Booth lighting (see 6.00).
- Directory and binder (see 7.00).
- Security of booth anchorage (refasten if loose).
- Tighten loose screws and bolts; replace if tightening is not possible. Repair or replace broken or missing parts.
- Use KS-14614 antiseize compound on screws threaded into aluminum.

1.01 Due to extensive revision marginal arrows have been omitted.

2.00 CLEANING

2.01 Booth should be free of loose dirt or other objectionable material.

- File or sand sharp edges, burrs, or splinters on exposed surfaces.
- Clean the ceiling assembly.

2.02 Booths may be cleaned with the following:

- Mild detergent in water.
- KS-8446 solvent which removes paint from aluminum surfaces.
- KS-7860 petroleum spirits which removes wax base substances (crayon, lipstick, etc).
- Bell System metal polish (liquid) which can be used for general cleaning of aluminum booths.

Note: Do not use abrasive materials that remove anodized finish on aluminum booths.

3.00 DOOR REQUIREMENTS (KS-14611 BOOTH)

3.01 Frames should not be broken or cracked (see 3.02).

- a. Door remains open 2 to 3 inches when it is at normal position (see 4.01). This clearance can be eliminated in cold weather, if desired. Adjust so that door closes without slamming.
- b. When pushed closed from inside, the door should remain completely closed.
- c. A slight pull on the handle should open and restore the door to normal position.
- d. Open-door clearance from the shelf is about 1 to 2 inches (see 4.02).

- e. Door operation should be free without binding, squeaking, or chattering (see 4.03).
- f. Rubber frame bumpers B-176635 shall be in place.

3.02 Replace door sections that have broken mitered joints. Repair solid-type (one piece) sections. (See Fig. 1.)

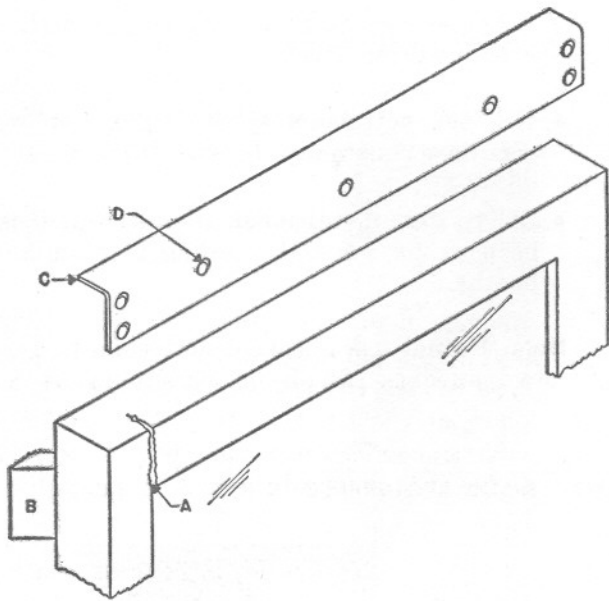

Fig. 1 – Door Repair Bracket

3.03 Fracture A usually occurs because of misuse or improper adjustment, or because booth is not level. Check the cause, and repair as follows:

1. Close door against a thin wooden block B to close fracture.
2. Place repair bracket C (B-931522) on the top outside of door. Align edge of bracket with edge of door that is closest to fracture.

3. Drill seven mounting holes D 1/2-inch deep (drill size No. 26). Use FH Phillips screws. No. 8-32 by 1/2 inch, self-tapping type F of corrosion-resistant steel.

Note: When brackets are installed on both door sections, check that brackets do not interfere with open position of door. Relocate felt bumper when necessary.

4.00 DOOR ADJUSTMENTS, FIG. 2

Normal Position

4.01 These adjustments should be made in sequence:

1. Loosen setscrew A (No. 10 [0.190]-32 by 3/16 inch, headless, set, cup).
2. Place door in normal position B (2 to 3 inches from corner post).
3. Position rod C (B-179474) against roller D (P-12A332). Check that spring E (B-176687) is not broken.
4. Secure rod in this position by placing collar F (B-177003) against bracket G (B-176686), and tighten screw.
5. Loosen mounting screws on adjustable door-stop assembly H (B-179336).
6. Move assembly left or right to obtain the spring tension required to return door to normal position. Tighten screws and re-check tension. Spring replacement is covered in 4.03, Step 2.
7. Check that assembly is not loose or damaged. Top of roller D should be inside of track L (B-178484) throughout door travel. Reposition guide assembly K (B-176782).

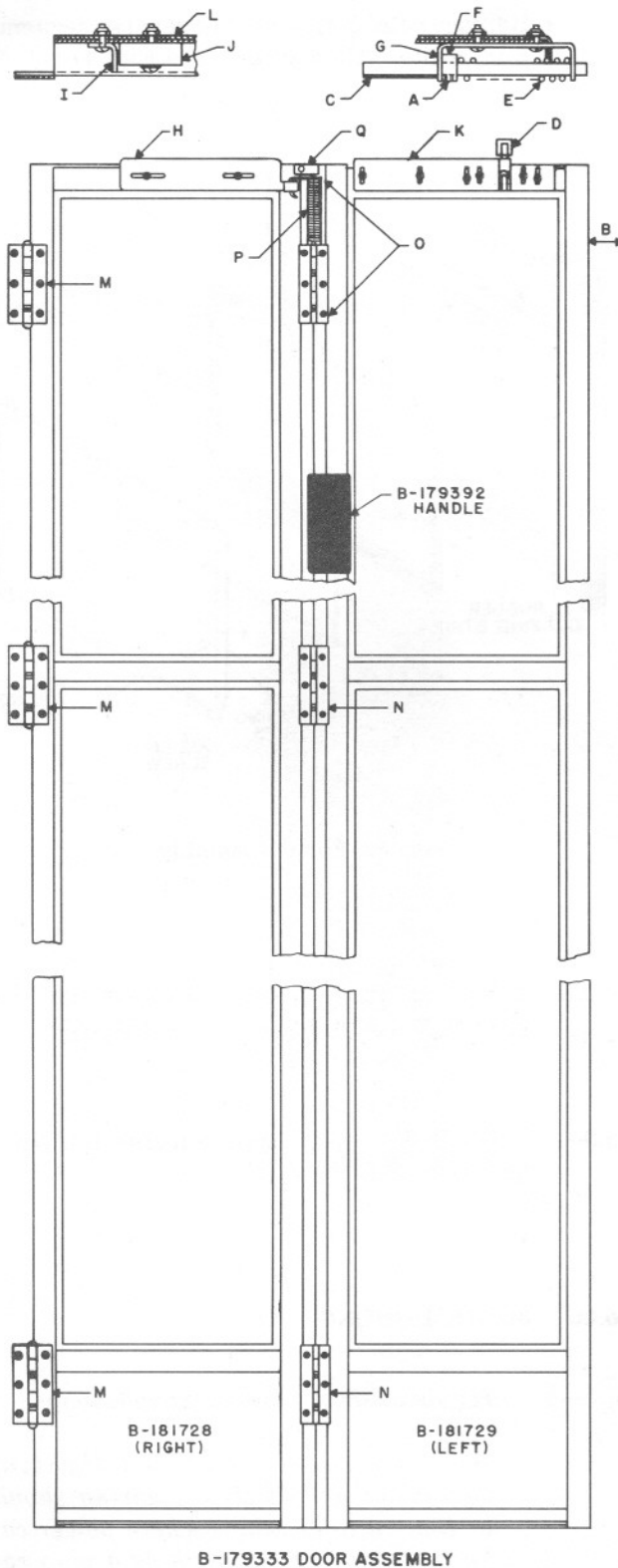

Fig. 2 - KS-14611 Booth Door Adjustments

Open Door Clearance

4.02 Check Points

- Angle I (B-179424) should be tight.
- Replace bumper J (B-179473) if worn or damaged.

Door Operation

4.03 Eliminate binding, squeaking, or chattering.

- Check hinge wear at M (B-185419), N (B-185420), and O (B-185421). Clearance between hinge barrels should not exceed 1/16 inch; gauge by eye. Replace worn hinges.

Note: Earlier type hinges do not have nylon washers.

- Replace defective springs P (B-179393) only if the top hinge assembly is the latest type having the removable support Q. Replace an earlier type top hinge assembly having a defective spring with a new top hinge O as shown in Fig. 3.

REMOVABLE SUPPORT
DRILL HOLE 1/2 IN.
DEEP WITH NO. 25 DRILL
FASTEN WITH SELF-
TAPPING SCREW TYPE F
8-32 X 1/2 IN.

FILE TOP HOLE IN
HINGE DOWNWARD
APPROX. 1/32 IN.

CENTER HINGE SCREW
MAY BE OMITTED

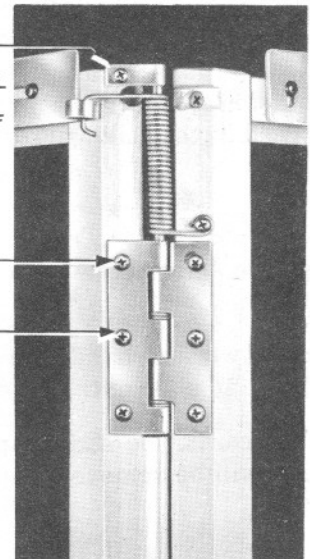

Fig. 3 - Installation of Top Hinge Assembly

- c. Lightly lubricate hinges, roller, springs, and door track with lubricant KS-14774, List 2. KS-14796 oiler can be used for application.

5.00 PANEL REPLACEMENT



SAFETY FIRST:

Wear gloves and eye protection when handling glass and wire glass panels to prevent personal injury.

Use care when handling tempered glass. Nicks or scratches may cause it to shatter.

Do not allow metal tools to come in contact with edge of tempered glass.

Before installation, examine glass for nicks or chips along edges. If such defects are apparent, do not use this glass.

5.01 Damaged or broken booth panels shall be made safe, and arrangements shall be made for replacement.

5.02 KS-14611 booth panels and signs are held in place by four interlocking retaining strips and are secured by Allen screws (8-32 by 1/4 inch, set, cup point, corrosion-resistant steel). When removing either panels or signs for replacement, proceed in the following sequence:

Removal:

- Remove Allen screw with a 5/64-inch Allen wrench.
- Insert wrench handle in hole provided in strip, and slide out.
- In all cases, the strip opposite the locking strip will be removed last.

Installation:

- Apply rubber glazing strip to panel or sign and insert in frame with the beaded edge of strip on the outside.

- Replace retaining strips in reverse sequence and tighten Allen screw (see Fig. 4).

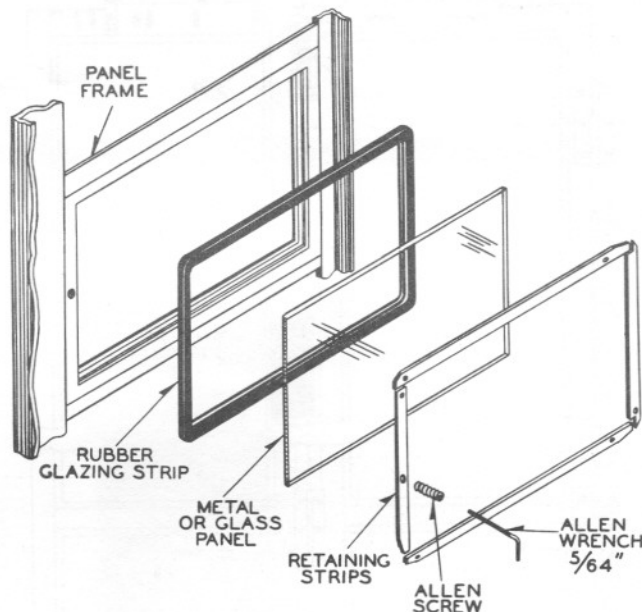

Fig. 4 – Panel Assembly

5.03 Table A lists panel replacements for KS-14611 booth.

5.04 Table B lists panel replacements for No. 9 booth.

6.00 BOOTH LIGHTING



For your safety, observe the following:

Work operations on booth lighting equipment and electrical wiring should be limited to locations where power can be turned off at a switch or a plug can be removed.

Wear eye protection when lowering ceiling and handling fluorescent lamps.

TABLE A
KS-14611 BOOTH PANELS

Panel KS-14611	Door	Side and Rear	Sign			
			Side and Rear		Front	
			*	†	*	†
List Numbers						
Glass (laminated)	12	11				
Glass (tempered)	18	17				
Red		13	32	30	22	27
Blue		14	33	29	23	26
Green		15	34	28	24	25
Black			31		21	
Aluminum (see note)		16	35			
Panel Strips						
Retaining B-185371-	Top	1	5	5	11	
	Left	2	6	9	12	
	Right	2	4	7	10	
	Bottom	3	5	5	13	
Rubber Glazing B-179367-	4	5	2		1	

* White translucent letters on colored background.

† Colored letters on white translucent background.

Note: Bottom louver panels (rear, B-179429-1; side, B-179429-2) also are replaceable when fastening screw-heads (later manufacture) are visible.

TABLE B
NO. 9 BOOTH PANELS

P-480034	Wire-glass Door Panel	Upper Section, Left Door
P-480035		Upper Section, Right Door
P-480036		Lower Section, Left Door
P-480037		Lower Section, Right Door
No. 56A	Wire-glass Side Panel	Upper Section of Booth Sides
No. 57A		Lower Section of Booth Sides
No. 58A	Masonite Side Panel	Upper Section
No. 59A		Lower Section

6.01 Both ceiling lamps should be lighted when power is on. When both lamps are out, proceed as follows:

1. Check that manual starter reset buttons are pushed in when this type starter is used. Allow one minute for lamps to light.
2. Unplug lamp cord in ceiling receptacle, and test for power.
3. If power is off, check for intermediate switch and report condition.
4. Replace lamp plug. Good lamps may light, see 6.04.
5. If lamps fail to function, replace starters and allow one minute for lighting. Replace lamps that do not light. (Before discarding a starter, test in a good lamp fixture.)
6. If lamps still fail to function, trouble may be due to low voltage (below 95 volts) or a defective fixture.

6.02 Thermal-type starters are used with the KS-14611 booth lamps. Bimetallic contacts control starter operation. If starter fails to light the lamp, a cutoff contact will open the lamp circuit. Starter remains in this cutoff condition until power is turned off, allowing bimetallic cutoff contact to cool.

- Purpose of cutoff is to prevent ballast transformer from overheating.

6.03 Starter cutoff usually occurs from the following:

- Low ac voltage or downward power surge (service interruptions, fluctuations, thunderstorms, etc) below operating range of lamp.
- Defective lamp (flickers when starting to light).

- Extremely low temperature at start. Gas in lamp does not ionize.
- High temperature, either at start, or while lamp is lighted. External heat combined with current flow operates bimetallic cutoff contact.

Note: Remember, the lamp starting time is determined by the temperature present in conjunction with lamp condition and line voltage.

6.04 Starter Selection

- **Automatic Reset** starters will reset after going into cutoff when the power is turned off to allow the contacts to cool. Operating range is from 20 degrees below 0 to 125 degrees.
- **Manual Reset** starters can be reset by pushing the reset button to render starter operative. Operating range is from 20 degrees below 0 to 175 degrees.

TABLE C

Lamp and Starter Codes

Watts	Lamp Code*	Starter Code	
		Reset	
		Automatic	Manual
32	FC12T10	TC-12	TC-120
40	FC16T10	TC-4	TC-40

* Lamp, fluorescent, 4-pin, standard, cool white.



Permanent damage to ballast transformer may result if the starter used is not correct for lamp wattage.

6.05 Defective retaining screws on list 2 ceiling bezel assembly (center hinged section) can be repaired as follows:

1. Remove 2 spring catches in ceiling.
2. Remove bezel assembly.
3. Install tie bracket B-186323 in ceiling. Re-use cap screws.
4. Install new modified bezel assembly B-183454.

6.06 Replacement ceiling panels are listed here.

- B-180041 ceiling bezel, 12 by 12 inches.
- B-183462-1 ceiling bezel, 12 by 21 inches.
- B-183462-2 left- or right-side panels.
- B-185369 dome (list 3 booth). Remove four frame screws and slide front of frame out.

6.07 The C Section entitled Booths and Shelves, Indoor, Maintenance covers lighting equipment common to the No. 9 booths.

7.00 DIRECTORIES AND BINDERS

7.01 Telephone directories should be in good condition. Replace binders having signs of excessive wear or damage. The KS-14611 booth directory rack should have rubber bumper in place to cushion the binder as it drops into rack.

7.02 The C Section entitled Telephone Directory Holders, Identification and Installation covers OD-type binder and binder cover replacement.

7.03 Install new rubber bumper B-179423 in the KS-14611 booth directory rack as follows:

1. Remove old adhesive after softening with trichloroethylene.
2. Install new bumper using MM and M Company EC-880 adhesive.