

## 6A KEY TELEPHONE SYSTEM

### SELECTOR ONLY

#### CONNECTIONS

#### 1.00 INTRODUCTION

1.01 This section covers the installation of the selector only of the 6A key telephone system. It contains wiring diagrams showing connections necessary to obtain the features desired.

1.02 This section has been reissued to bring the connection data up to date.

1.03 Due to extensive changes marginal arrows have been omitted.

1.04 The installation of apparatus, key telephone units, keys, station sets, and other items common to general station work is not covered in this section; it is covered in the C Section pertaining directly to each item.

1.05 A careful review of the immediate needs of the customer, together with a consideration of his future rearrangements and requirements, will be beneficial in determining the method of installation. Each installation should be arranged in a manner that will permit maximum flexibility under the particular circumstances.

#### 2.00 WIRING AND CABLING

Inside wire and cable are used to install a 6A key telephone system. Information relative to placing wire and cable is contained in other C Sections.

#### 3.00 APPARATUS

Refer to the C Section covering identification of the 6A key telephone system for the dimensions of each KTU and for the features each provides.



*Handling of key telephone units sometimes results in damage to wire spring relays. After mounting, visually inspect all wire spring relays for the following:*

- Improper position of contact springs.
- Broken actuating cards.
- Improper position of actuating cards.

#### 4.00 POWER SUPPLY

4.01 The 6A key telephone system is designed to operate from a 20- to 26-volt dc source. Since associated installations of other key equipments or key systems operate at a somewhat lower value, 14 to 26 volts, it may be necessary to replace the existing power supply or use an independent supply for the 6A system equipment.

4.02 The J86471A, List 1 (101J) power plant has a capacity large enough to be used as a common power plant for combined station systems. When used with 6A systems, it is recommended that the leads from the dc unit connect to the 24-volt taps on the ac unit. Fuse as follows:

#### DC Unit

- One 2-amp fuse for battery designated A.
- One 2-amp fuse for battery designated B.

## SECTION C71.012

### AC Unit

- One 2-amp fuse on 10-volt ac tap for maximum thirty-six 51A lamps.
- One 2-amp fuse on 18-volt ac tap for maximum current drain of 1.6 amp for buzzers or bells.

If ringers are used, a separate power source supplying 105 volts 20 cycles must be provided.

**4.03** The J86731A, List 4 (101G) power plant may be used for any size and arrangement of the 6A key telephone system with the following limitations:

- No load other than the 6A is placed on the power plant.
- 20-volt talk terminals are used only for battery designated A.
- 20-volt signal terminals are used only for battery designated B.
- 18-volt ac terminals, audible and/or visual signals, do not exceed 1.4 amp.
- 10-volt ac terminals operate a maximum of seventy-two 51A lamps, current drain not to exceed 2.8 amp.



*When both the 10-volt ac and 18-volt ac taps are used on the power plant, the maximum joint current drain shall not exceed 1.4 amp.*

- 105-volt  $\pm$  terminals operate simultaneously one to eight high-impedance ringers without capacitors or one or two high-impedance ringers with capacitors (one to three if 70 to 110 volts or one to five if 60 to 110 volts is permitted).

- If circuit failure occurs due to low line voltage, move the primary tap to 111 volts.

**4.04** For power supply arrangements, refer to C Section covering station systems power supply.

### 5.00 FUSING

When central office, building, or local batteries are supplied, fuse the circuits as follows:

- One 2-amp fuse for talking battery, designated A.
- One 2-amp fuse for signaling battery, designated B.
- One 2-amp fuse per maximum of 36 signal lamps, designated C.
- One 2-amp fuse for dc audible signal supply, designated D.

### 6.00 CONNECTIONS

**6.01** The connection diagrams serve as a guide to the installer in connecting the 6A equipment units to provide the desired features.

**6.02** Certain features can be obtained by strapping between individual key units. Other features require such leads as *T, R, L, LG, S, S1, A, and A1*, normally associated with station apparatus. For ease of wiring, both at the time of original installation and at the time of future additions or rearrangements, it is suggested that such leads be brought out and terminated at a common cross-connecting point.

**6.03** The following information on the use of the connection diagrams should be helpful:

- Determine from the service order and work sheet the features required by the customer.
- Consult 7.00 for wiring options needed to obtain the desired features.
- Determine the key telephone units needed by consulting the C Section covering identification of 6A key equipment.

### 7.00 WIRING OPTIONS

The wiring options found in Table A are applicable to the selector only arrangement.

**TABLE A**

Wiring	Option
<i>X</i>	Without Transfer Circuit (Max Nine Codes)
<i>W</i>	With Transfer Circuit (over Nine Codes)
<i>K</i>	System with Preset Conference Circuit
<i>H</i>	Under 40 Lamps on System (without Aux Rel Busy Lamp Ckt)
<i>M</i>	Over 40 Lamps on System (with Aux Rel Busy Lamp Ckt)
<i>R</i>	Long Line Ckt Associated with Preset Conference Ckt

### 8.00 INDEX OF FIGURES

Fig. 1 — Selector Circuit Connections to Transfer Circuit

Fig. 2 — Addition of Add-On Conference Circuit

Fig. 3 — Addition of Preset Conference Circuit

Fig. 4 — Addition of Long Line Circuit

Fig. 5 — Addition of Auxiliary Relay Busy Lamp Circuit

**REFERENCE:** SD-69286-01

SECTION C71.012

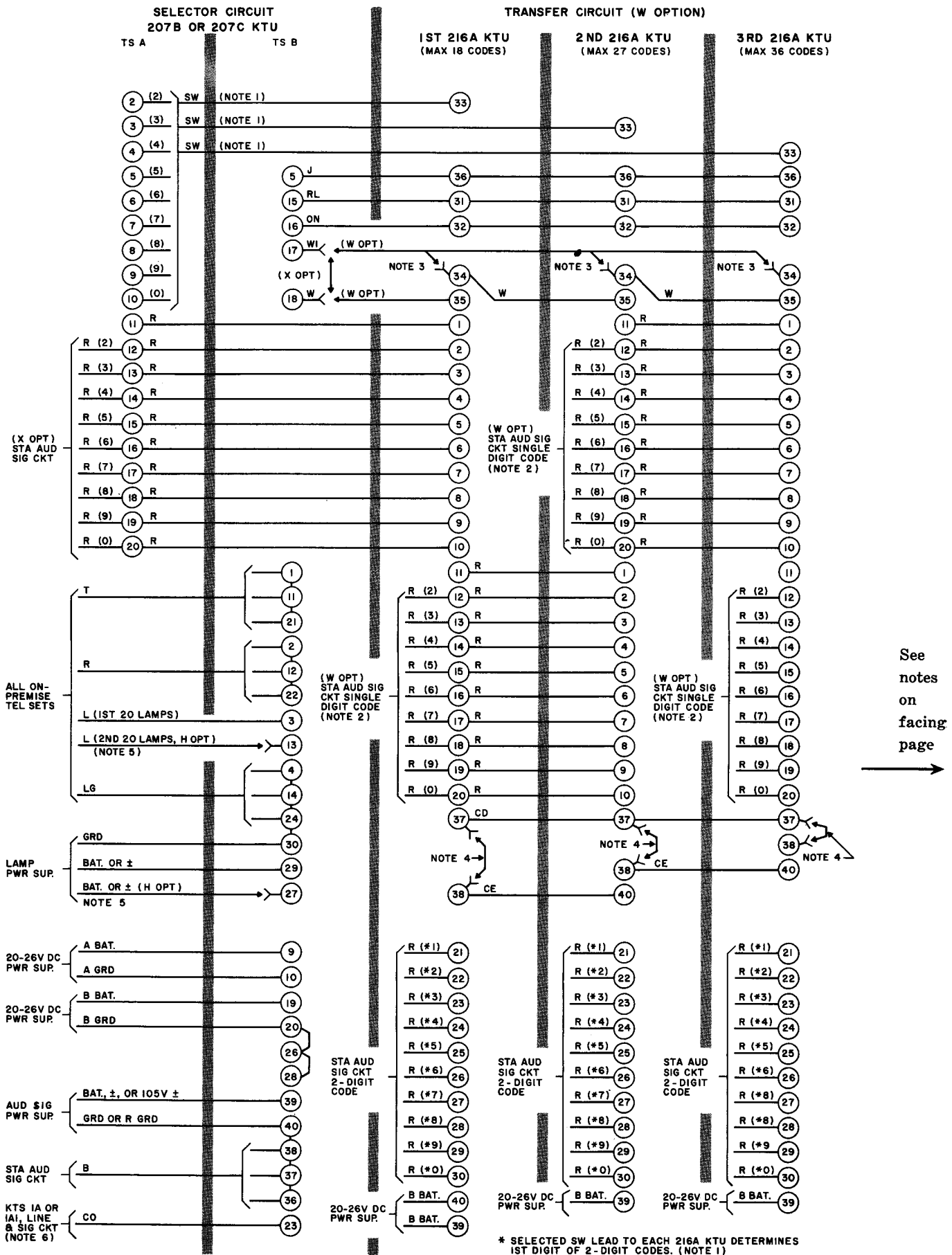

See notes on facing page

Fig. 1 - Selector Circuit Connections to Transfer Circuit

\* SELECTED SW LEAD TO EACH 216A KTU DETERMINES 1ST DIGIT OF 2-DIGIT CODES. (NOTE 1)

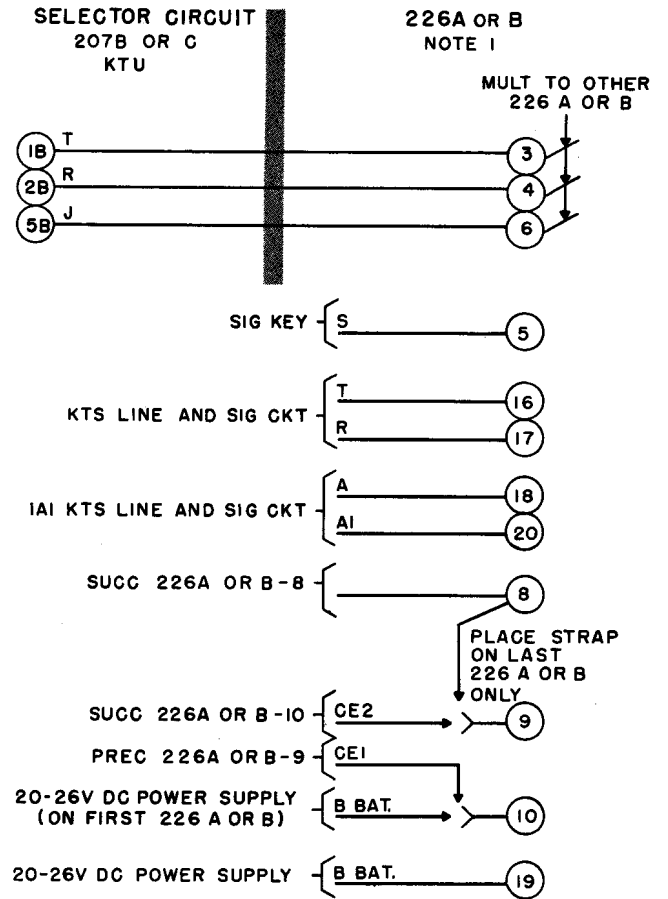

**Notes for Fig. 1**

**Note 1:** Any digit other than 1 may be assigned as the initial digit of a 2-digit code. The number so assigned may not be used for a station code. Any three *SW* leads, 2 through 0, connect to a maximum of three transfer circuits (one lead per transfer circuit). The other leads can be used as *C* leads to operate off-premise and preset conference circuits.

**Note 2:** *R* leads assigned to single digit codes for *W* option must be wired from the last transfer circuit provided.

**Note 3:** Connect *W1* lead (*W* opt) from terminal 17B (207B or C) to the last transfer circuit provided.

**Note 4:** Place strap only on last transfer circuit provided.

**Note 5:** A total of 40 lamps can be provided by this circuit. If more lamps are needed, use the auxiliary relay busy lamp circuit.

**Note 6:** The *CO* lead is required when the selector only arrangement is associated with KTS 1A or 1A1.

**Note 1:** Provide one 226A or B for each central office or PBX line to be conferenced.

**Fig. 2 — Addition of Add-On Conference Circuit**

SECTION C71.012

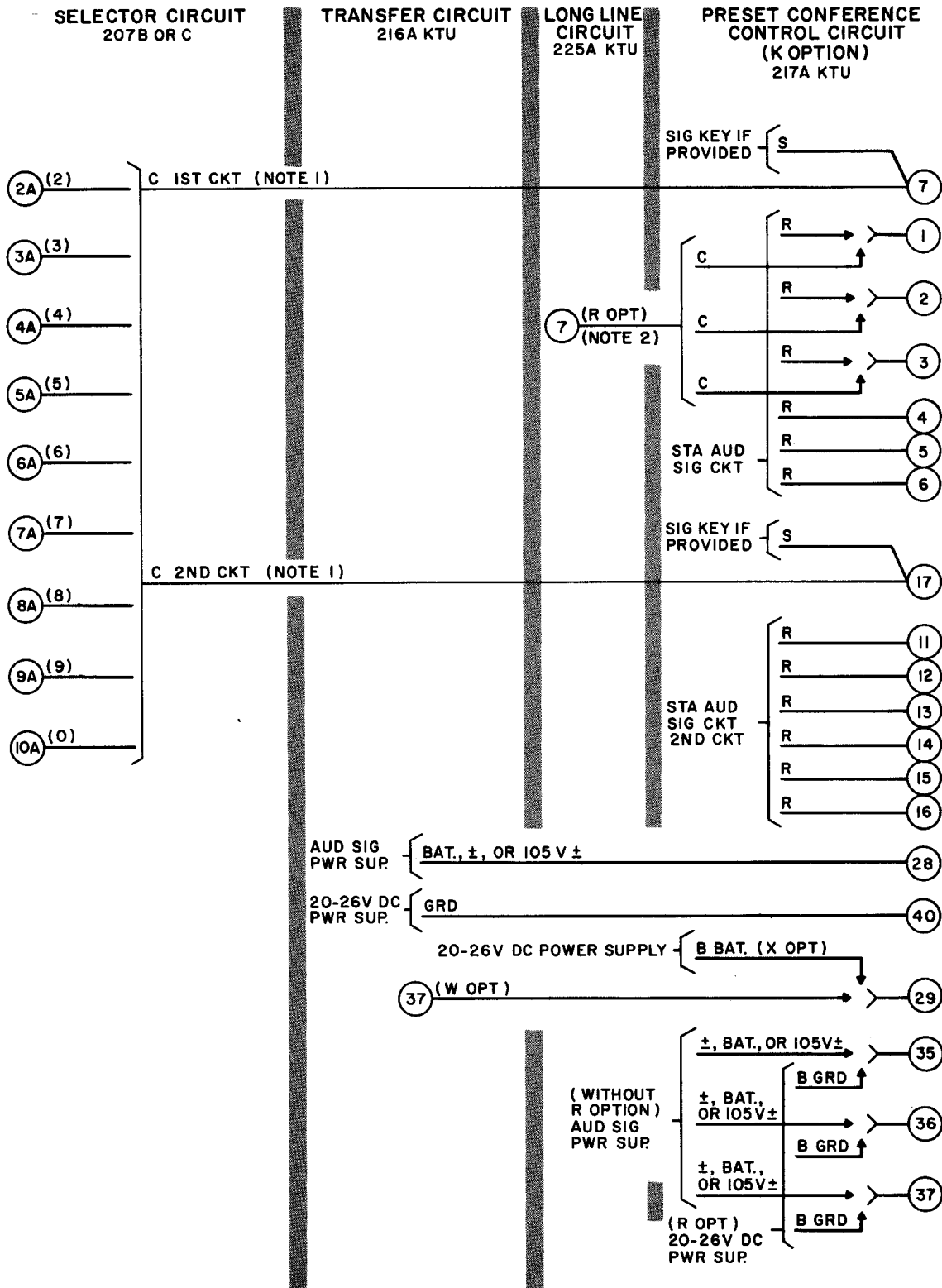

**Note 1:** C leads that operate preset conference circuits must connect through the first bank of the selector when the selector only arrangement is used. Single digit codes must be assigned to operate preset conference circuits.

**Note 2:** Maximum of three off-premise stations may be included on the first conference circuit of each 217A provided.

**Fig. 3 – Addition of Preset Conference Circuit**

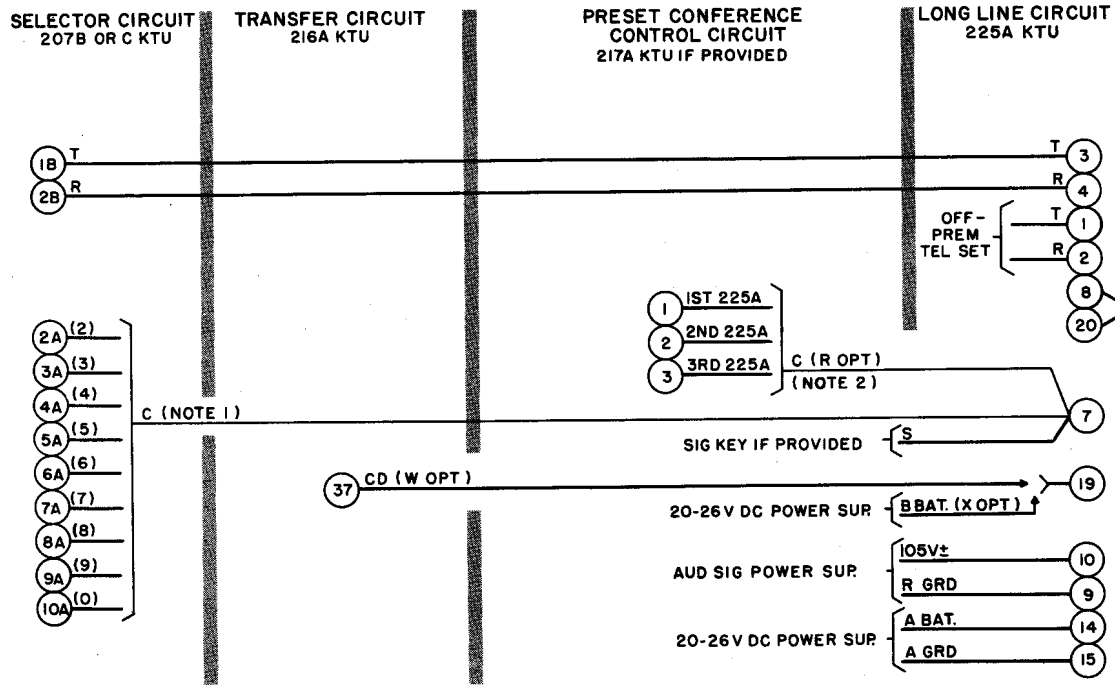

**Note 1:** C leads that operate long line circuits must connect through the first bank of the selector when the selector only arrangement is used. Off-premise stations must be assigned single-digit codes.

**Note 2:** Maximum of three off-premise stations may be included on the first conference circuit of each 217A provided.

**Fig. 4 - Addition of Long Line Circuit**

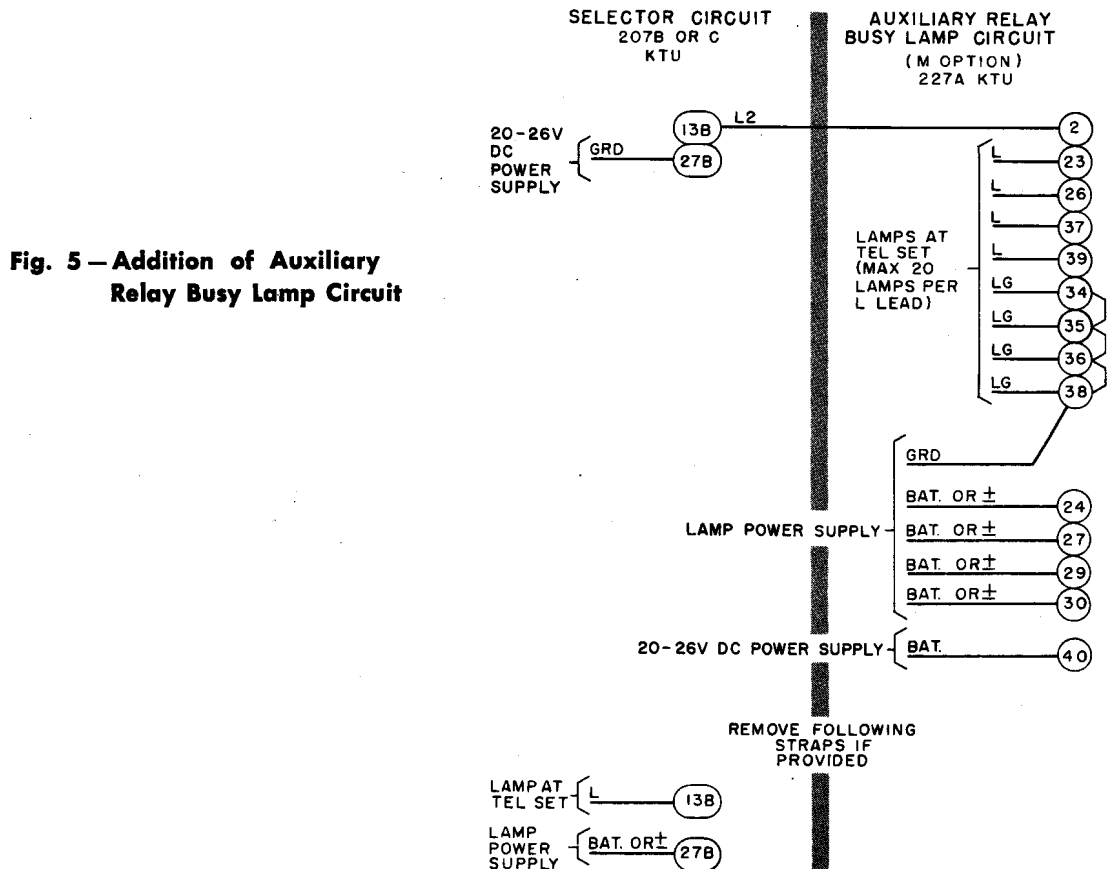

**Fig. 5 - Addition of Auxiliary Relay Busy Lamp Circuit**