

**6A KEY TELEPHONE SYSTEM
 SELECTOR ONLY ARRANGEMENT
 MAINTENANCE**

CONTENTS	PAGE
1.00 INTRODUCTION	1
2.00 GENERAL	1
3.00 LINE SEIZURE, Fig. 1	4
4.00 BASIC OPERATION OF SELECTOR CIRCUIT, Fig. 2	5
5.00 STATION SELECTION, DIALING SINGLE-DIGIT CODE	6
6.00 STATION SELECTION, DIALING 2-DIGIT CODE, Fig. 3	7
7.00 STATION SELECTION, USING SIGNAL KEY	8
8.00 TALKING PATH, Fig. 4	9
9.00 AUDIBLE SIGNALS, Fig. 5	10, 11
10.00 VISUAL SIGNALS, Fig. 6	13
11.00 PRESET CONFERENCE, Fig. 7	14, 15
12.00 ADD-ON CONFERENCING, Fig. 8	16, 17
13.00 OFF-PREMISE STATION, LINE SEIZURE, Fig. 9	18
14.00 OFF-PREMISE STATION, INCOMING CALL, Fig. 10	19
15.00 OFF-PREMISE STATION, ANSWERING INCOMING CALL, Fig. 11	20

1.00 INTRODUCTION

1.01 This section covers the maintenance of the selector only arrangement of the 6A key telephone system, the use of sequence charts and operational sketches, and a description of the symbols used.

1.02 Due to extensive changes marginal arrows have been omitted.

2.00 GENERAL

2.01 The circuits used in the 6A key telephone system have been reduced to simplified sequence charts and operational sketches.

- Sequence charts cover the operation and release of relays, keys, and other apparatus in their relative time order. They are shown from the top downward and are connected by appropriate lines to show the interdependence of the successive operations.

- Operational sketches show complete circuits from battery to ground in simplified form, completely disregarding boundaries of conventional SD drawings. Key telephone unit numbers beneath the complete circuit identify key telephone units in which the individual relays, relay contacts, or other apparatus are located.

USE OF SEQUENCE CHARTS AND OPERATIONAL SKETCHES

2.02 After it has been determined that the trouble is in the 6A equipment, proceed as follows:

- Watch relay operation of equipment and compare it to that of the sequence charts as shown on the various figures.
- Where circuit failure occurs, the operational sketch either will show the complete path for the circuit that failed or it will refer to the figure where the complete path may be found.

2.03 The following are samples of some of the symbols used in the preparation of the sequence charts and operational sketches contained in this practice.

SEQUENCE CHART SYMBOLS

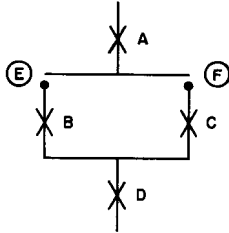
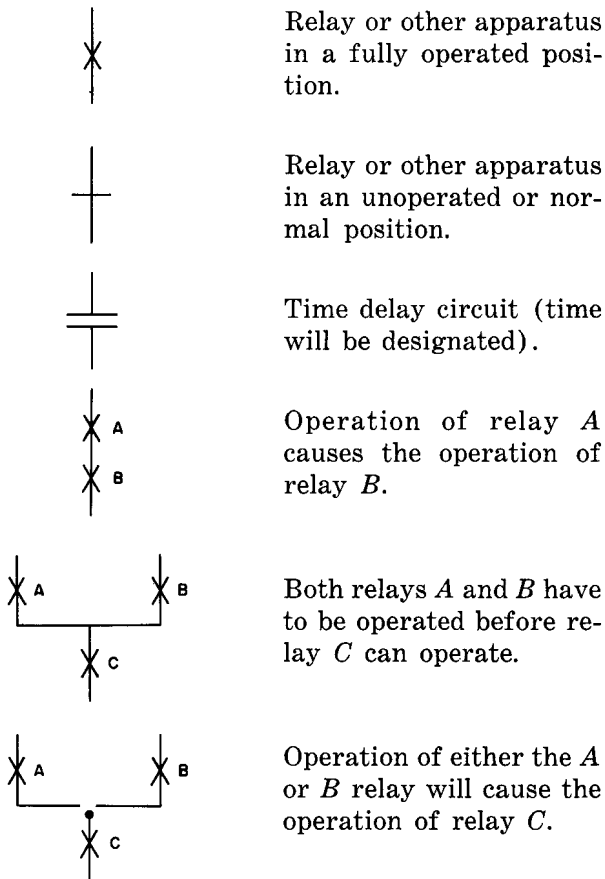

Option: Relay A, in operating, operates relay B or C depending on the wiring option provided. Relay B or C in operating would in turn operate relay D.

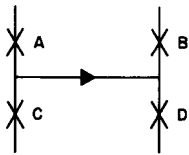

Both relays A and B must operate before relay D can operate. The arrow is used to indicate one-way action. In this illustration, relay C operates from relay A only.

OPERATIONAL SKETCH SYMBOLS

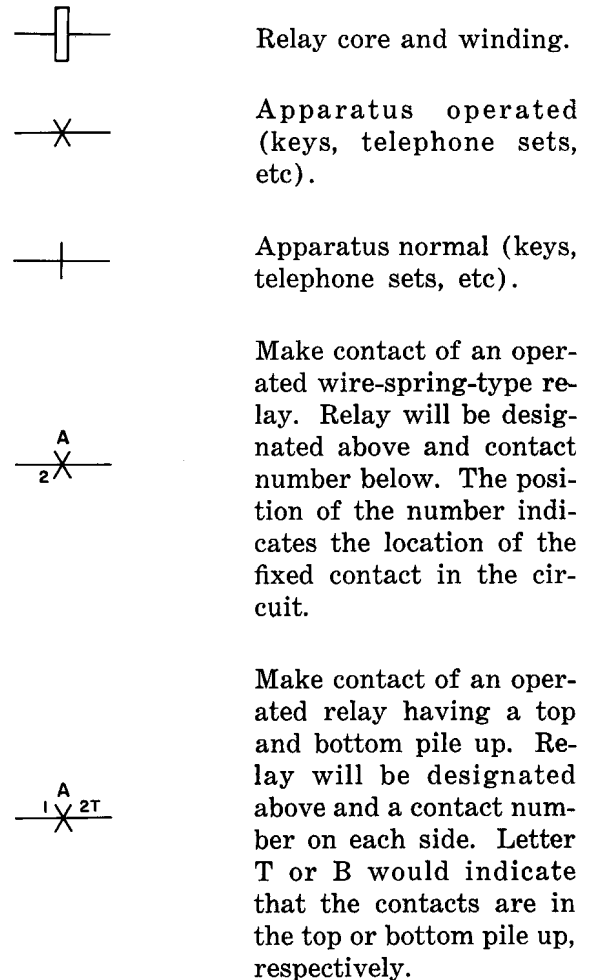



Normally closed contact of an unoperated wire-spring-type relay. Relay will be designated above and contact number below.

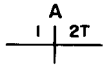

Normally closed contact of an unoperated relay having a top and bottom pile up. Relay will be designated above and a contact number on each side.

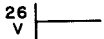

Battery symbol (B battery unless designated otherwise).



Ground symbol.

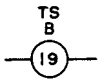

Point of termination, terminal strip B, terminal 19.

2.04 A description of the operation, supplementing the sequence charts, is provided to specify the functions of the equipment.

2.05 The sequence charts and operational sketches in this section supplement, but do not replace, CD and SD-69286-01.

2.06 General maintenance of telephone sets, dials, keys, relays, power plants, etc, used with the 6A key telephone system is not covered in this section. References should be made to the C Series pertaining to these specific items.

2.07 The following wiring options are applicable to this section.

Wiring	Option
X	Without Transfer Circuit (max nine codes)
W	With Transfer Circuit (over nine codes)
H	Under 40 Lamps on System (without aux rel busy lamp circuit)
M	Over 40 Lamps on System (with aux rel busy lamp circuit)
R	Long Line Circuit Associated with Preset Conference Circuit
K	System with Preset Conference

SEQUENCE CHART

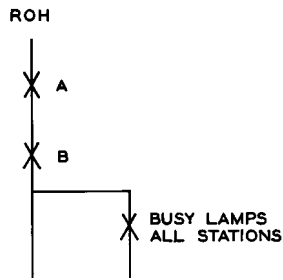

3.00 LINE SEIZURE

The *T* and *R* leads of a 6A key telephone system station are connected to battery and ground through the windings of the *A* relay. As a station picks up, relay *A* operates and causes the operation of relay *B*. Relay *B* in operating causes the busy lamps, if provided, to light steadily at all stations.

Reference: SD-69286-01

OPERATIONAL SKETCH

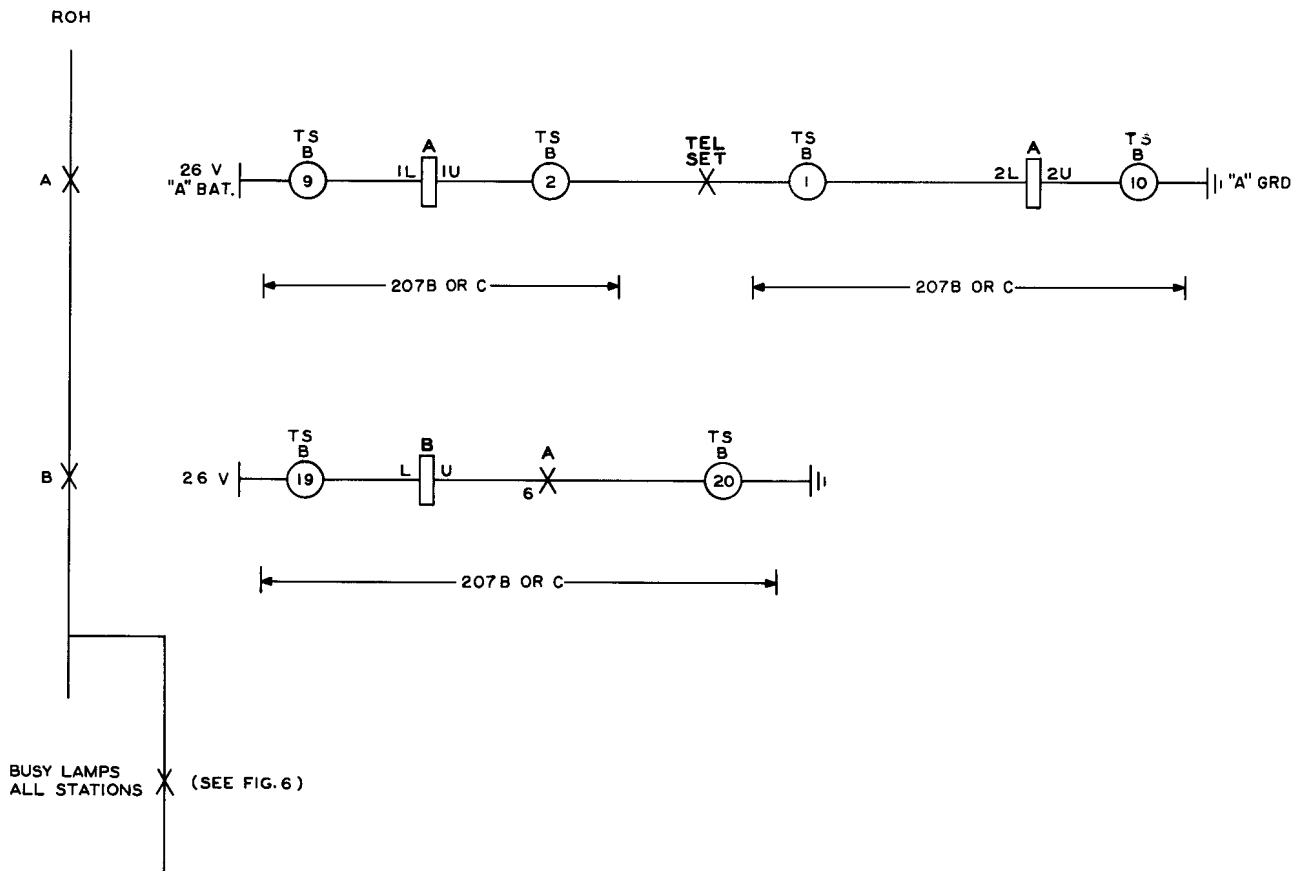

Fig. 1 - Line Seizure

4.00 BASIC OPERATION OF SELECTOR CIRCUIT

4.01 Relays *A* and *B* have previously been operated as described in 3.00. As each digit is dialed, relay *A* releases and reoperates in unison with the dial pulses. Slow release relay *B* remains operated during dialing. As the *A* relay pulses, a ground is connected to the rotary magnet causing the selector switch to step in unison with the dialed pulses.

4.02 A slow releasing relay *C* operates on the first release of relay *A* and remains operated during the pulse train. This relay causes operation of the *T* relay which in turn connects a resistor and capacitor across its winding. The capacitor is charged during pulsing, and its discharge after the release of relay *C* holds the *T* relay operated for approximately 1-1/2 seconds, thus providing the timing interval used to control the audible signal to the called station.

SEQUENCE CHART

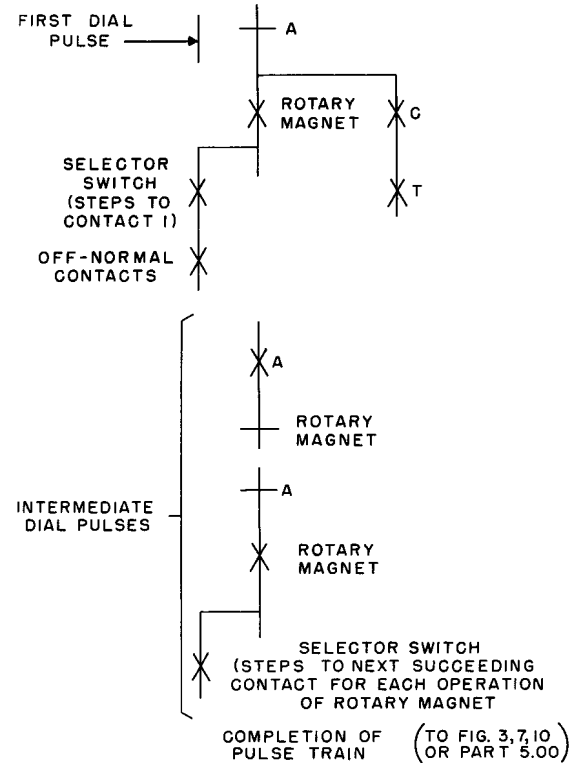

Reference: SD-69286-01

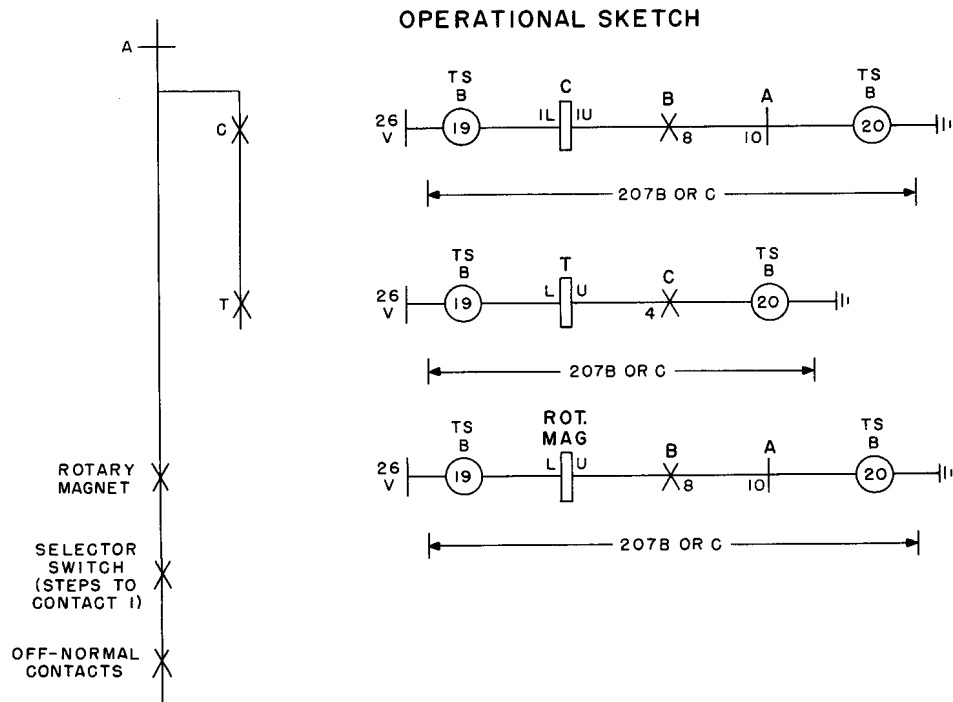

Fig. 2 – Basic Operation of Selector Circuit

5.00 STATION SELECTION, DIALING SINGLE-DIGIT CODE

5.01 At the completion of the pulse train, relay *A* reoperates and relay *C* releases. The *C* relay in releasing: (a) connects audible signal power supply to the called station's audible signal and (b) opens the operate path for the *T* relay.

5.02 After a nominal 1-1/2 second time delay, relay *T* releases. The release of relay *T*: (a) opens the audible signal power supply path to the audible signal and (b) provides an operate path for the release magnet. The operation of the release magnet causes the selector switch to release, which in turn restores the off-normal contacts to their normal position. This in turn opens the operate path of the release magnet.

Reference: SD-69286-01

SEQUENCE CHART

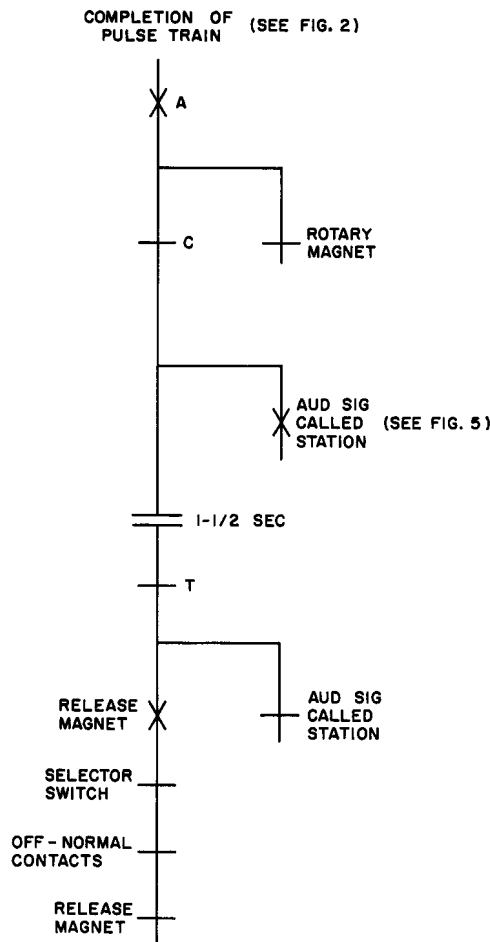

6.00 STATION SELECTION, DIALING 2-DIGIT CODE

6.01 The first digit of a 2-digit code is used as a transfer code. After completion of a pulse train at the end of the first digit, relay *A* reoperates and relay *C* releases.

6.02 Relay *RL* now operates under control of all normal *TR* relays, the selected *SW* lead on the first bank of the selector switch, the operated *T* relay, and the released *C* relay. The *RL* relay in operating: (a) locks up to the *B* relay and (b) operates the release magnet of the selector circuit.

6.03 The release magnet in operating causes the selector switch to release which in turn restores the off-normal contacts to their normal position. This causes the *TR* relay to operate. The *TR* relay in operating: (a) locks up, (b) transfers the *R* leads (connected to the second bank of the selector switch) from the single-digit code stations to the selected group of 2-digit stations, and (c) prevents any other *RL* relay, which may be provided, from operating when the second digit is dialed.

6.04 After completion of the pulse train at the end of the second digit, audible signal power supply causes the operation of the station audible signal (as described in 9.00).

Reference: SD-69286-01

SEQUENCE CHART

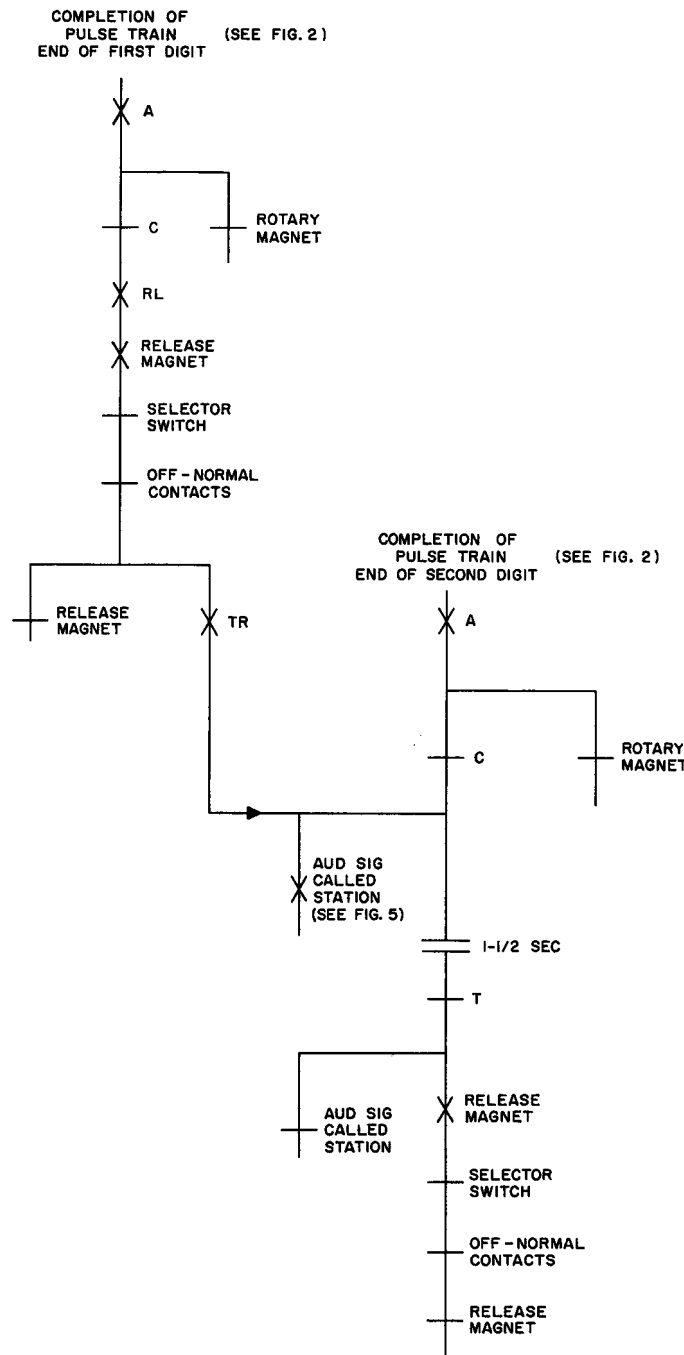

OPERATIONAL SKETCH

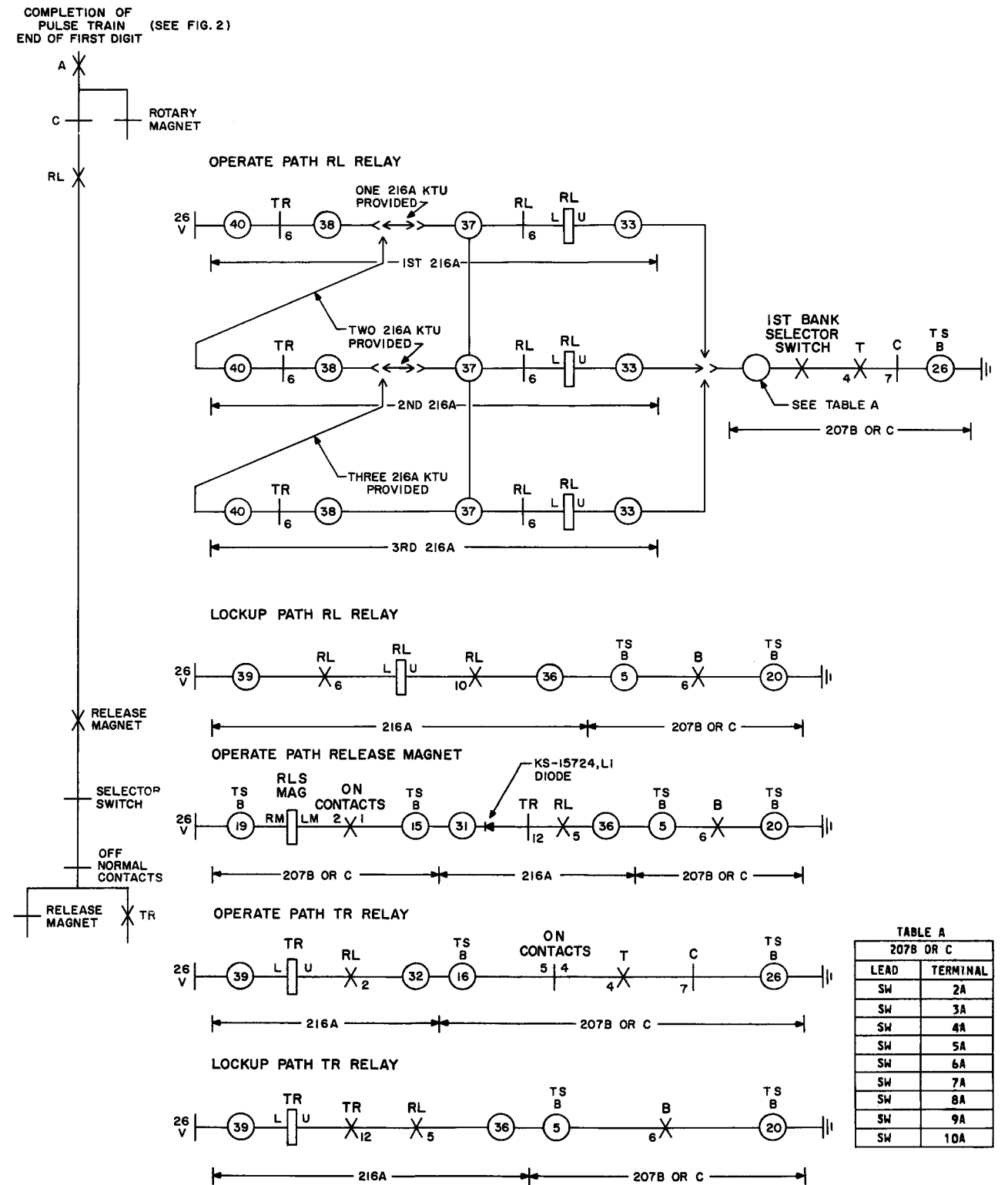

Fig. 3 - Station Selection, Dialing 2-Digit Code

7.00 STATION SELECTION, USING SIGNAL KEY

A station may be selected through the operation of a signal key which will connect ringing power supply to a bell or buzzer at the called station. If a ringer is used at the called station, the signaling key may be used to operate a relay which in turn will connect the ringing power supply. Since this arrangement gives the equivalent of an ordinary inter-communicating circuit, as covered in the 1A1 key telephone system, it will not be shown on a drawing and may be engineered on a local basis.

Reference: SD-69286-01

8.00 TALKING PATH

8.01 The calling station has selected and signaled the called station as described in 5.00, 6.00, or 7.00.

8.02 The called station responds to the audible signal and connects its telephone circuit to the *T* and *R* leads. Both stations are now connected to a common *T* and *R* path with talking battery being supplied through the windings of the *A* relay.

SEQUENCE CHART

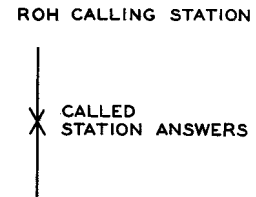

Reference: SD-69286-01

OPERATIONAL SKETCH

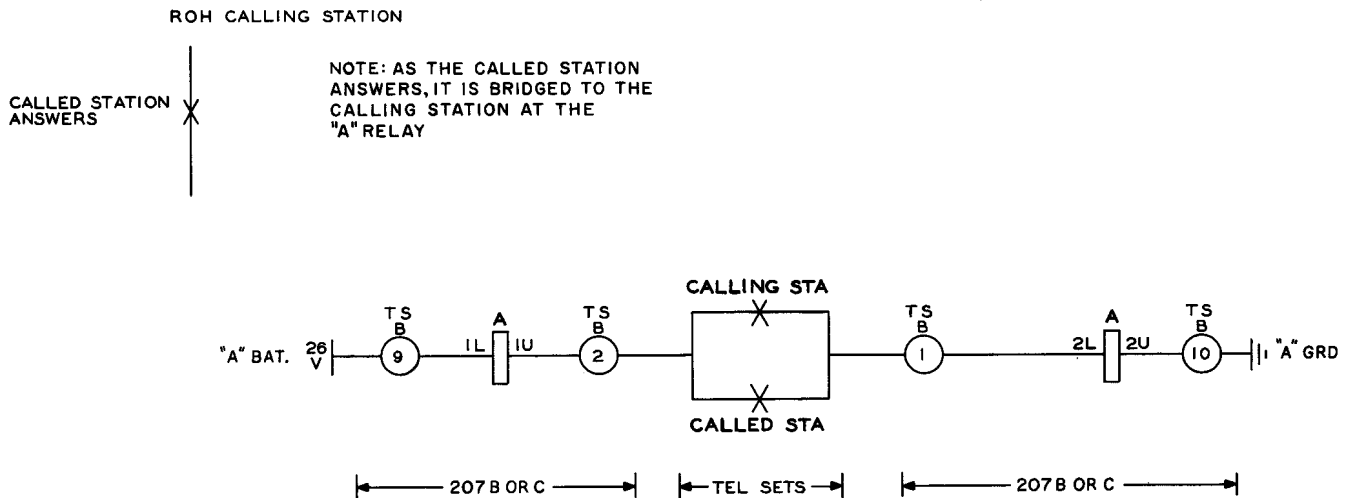

Fig. 4 — Talking Path

SECTION C71.017

9.00 AUDIBLE SIGNALS

9.01 A separate signal pair is required to operate the audible signal.

DIALING SINGLE-DIGIT CODE

9.02 The release of relay *C* (as described in 5.00) connects audible signal power to the called station's audible signal, under control of relays in

the selector circuit, the second bank of the selector switch, and all normal *TR* relays if provided.

DIALING 2-DIGIT CODE

9.03 The release of relay *C* at the end of the second digit (as described in 6.00) connects audible signal power to the called station's audible signal, under control of relays in the selector circuit, the second bank of the selector switch, and the operated *TR* relay.

Reference: SD-69286-01

SEQUENCE CHART

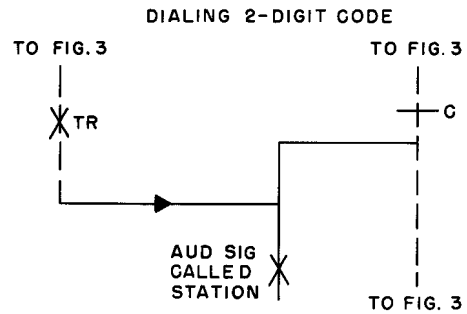
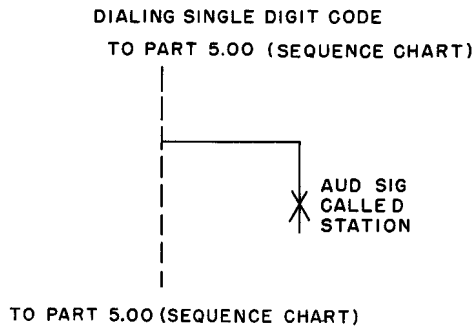

OPERATIONAL SKETCH

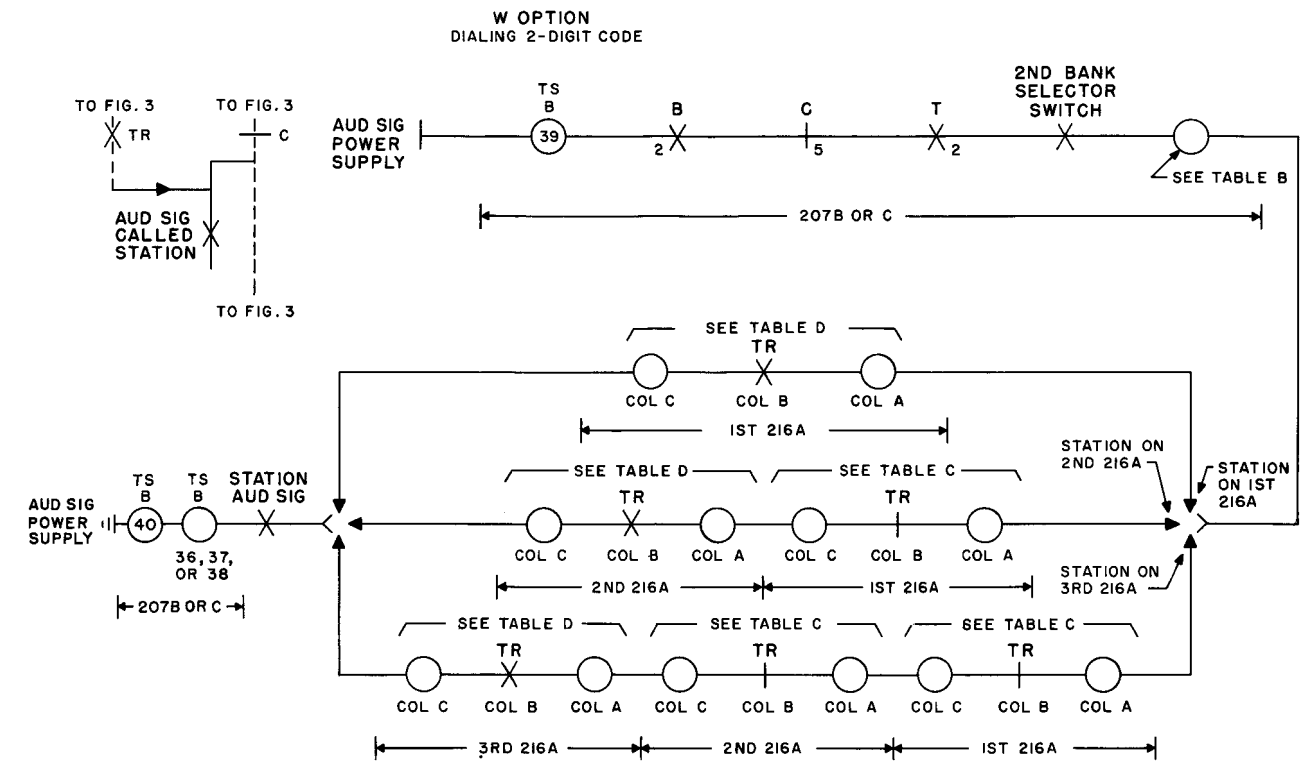
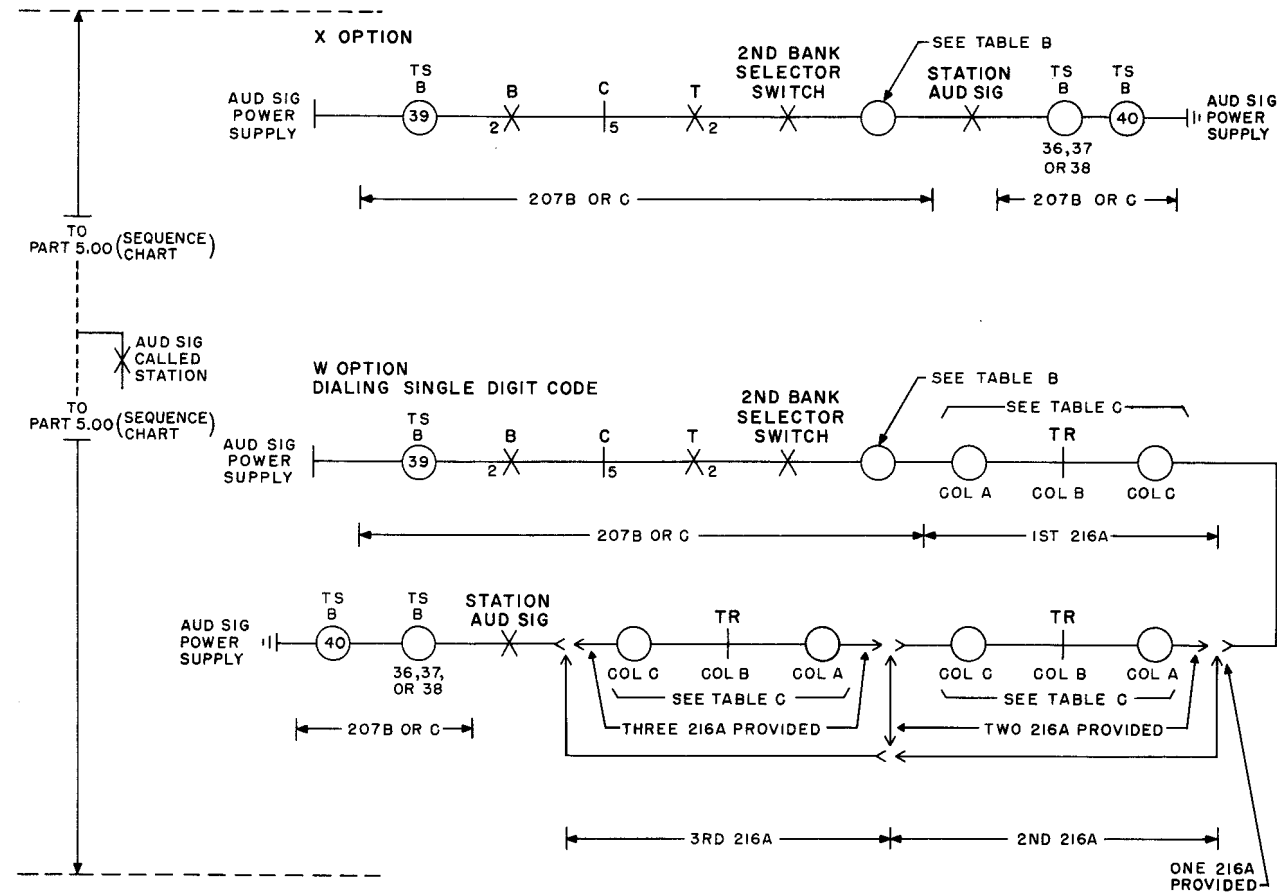

TABLE B

207B OR C	
LEAD	TERMINAL
R *	11A
R	12A
R	13A
R	14A
R	15A
R	16A
R	17A
R	18A
R	19A
R	20A

* USED WITH 2-DIGIT CODE ONLY

TABLE C

216A KTU TR RELAY NORMAL		
COL A TERM.	COL B CONTACT	COL C TERM.
1	8	11
2	1	12
3	2	13
4	3	14
5	4	15
6	7	16
7	9	17
8	10	18
9	11	19
10	5	20

TABLE D

216A KTU TR RELAY OPERATED		
COL A TERM.	COL B CONTACT	COL C TERM.
1	8	21
2	1	22
3	2	23
4	3	24
5	4	25
6	7	26
7	9	27
8	10	28
9	11	29
10	5	30

Fig. 5 - Audible Signals

10.00 VISUAL SIGNALS

Relays *A* and *B* operate on pickup as described in 3.00. The operation of the *B* relay closes the lamp battery supply path to light the busy lamps at all associated stations.

Reference: SD-69286-01

SEQUENCE CHART

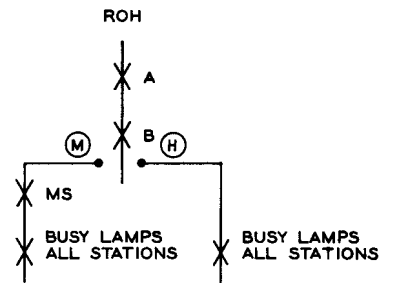

OPERATIONAL SKETCH

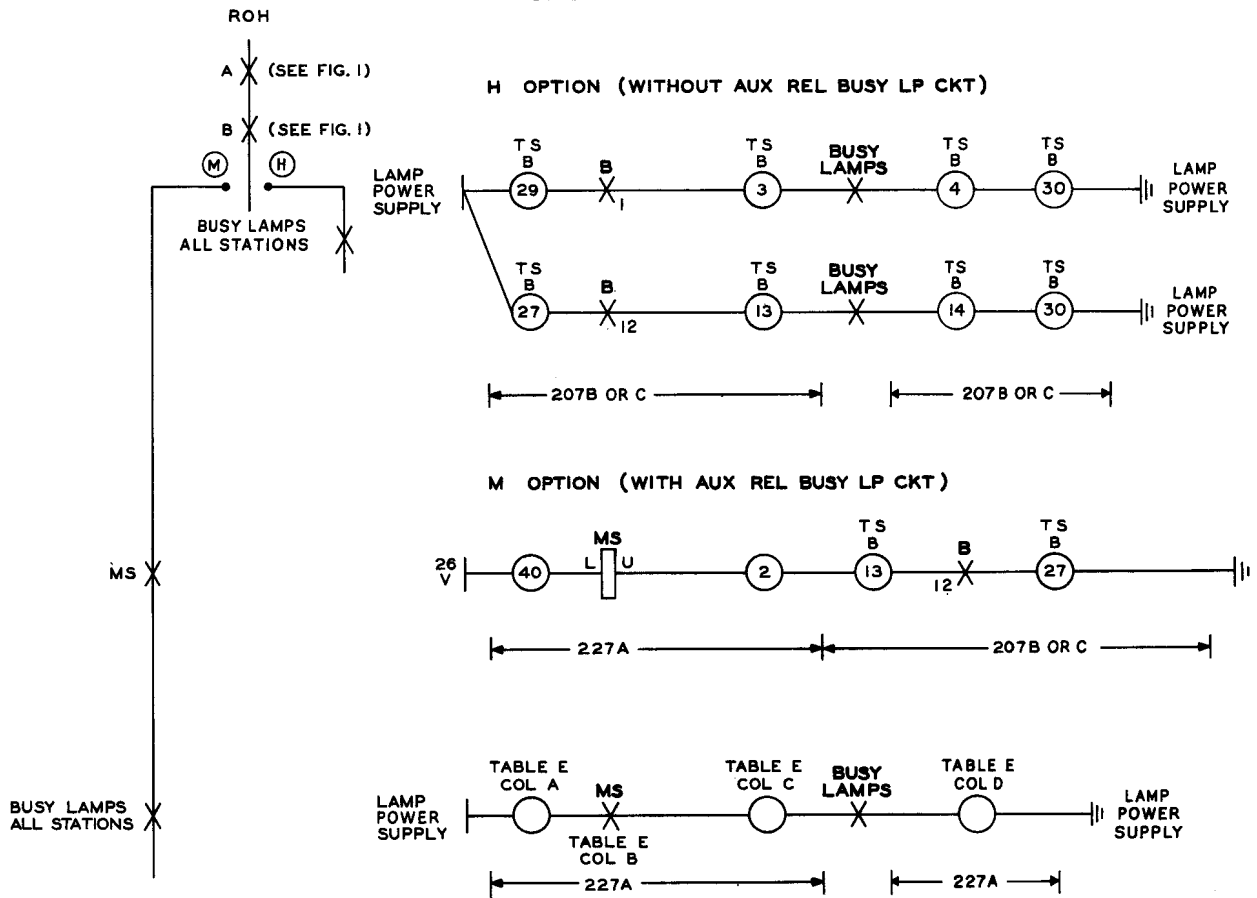

TABLE E

COL A	COL B	COL C	COL D
PCHG	OPR CONT	PCHG	PCHG
24	8	23	34
27	6	26	35
29	10	37	36
30	4	39	38

Fig. 6 – Visual Signals

11.00 PRESET CONFERENCE

11.01 A preset conference can be established by dialing a code or by the use of a signal key.

11.02 After line seizure has been accomplished, as described in 3.00, a ground is connected to the preset conference circuit under control of the selector circuit if the dial was used or under control of an operated signal key. This ground will cause the operation of relay *RO1*, under control of either the *PC1* or *PC2* relay. In operating, the *RO1* relay connects battery to the *PC1* and *PC2* relays and locks up under their control.

11.03 The *PC1* or *PC2* relay will now operate. The operation of the *PC1* or *PC2* relay will:

(a) lockup, (b) release the *RO1* relay, and (c) connect audible signal power to a maximum of six on-premise station audible signals. When off-premise stations (maximum of three) are to be included in the preset conference, they must be connected to punchings 1, 2, or 3 of the *PC1* relay. When the *PC1* relay operates as described above, a ground is supplied to operate the long line circuit.

11.04 When the dial is used, the *T* relay in the selector circuit releases at the end of the nominal 1-1/2 second interval. The release of relay *T* releases the *PC1* or *PC2* relay, as the case may be, thus opening the audible signal path to the called stations. With the use of a signal key, the audible signal at the called stations will operate as long as the key is depressed.

Reference: SD-69286-01

SEQUENCE CHART

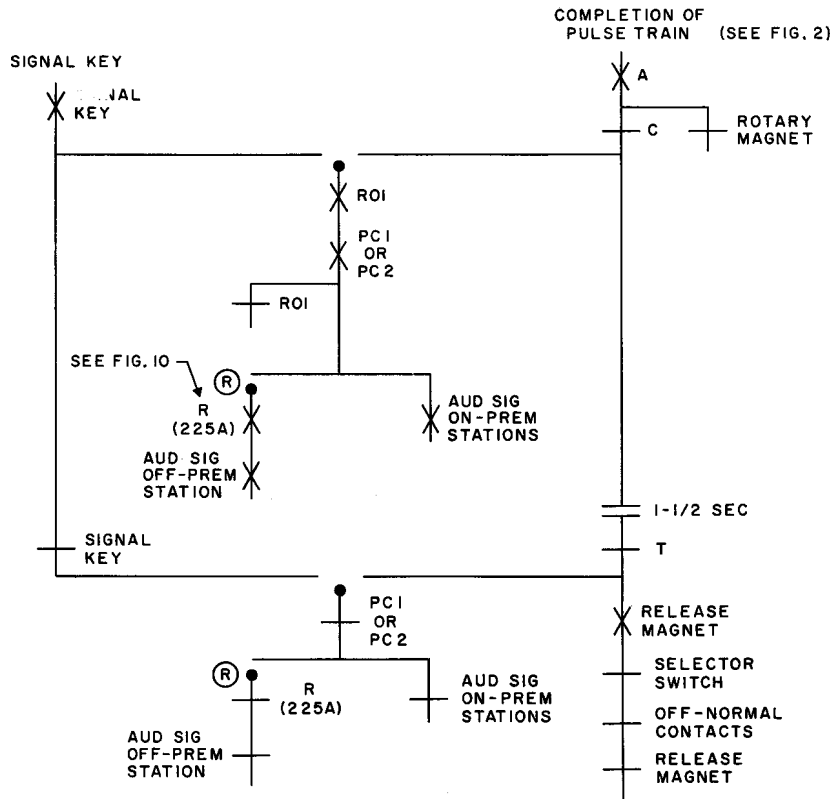

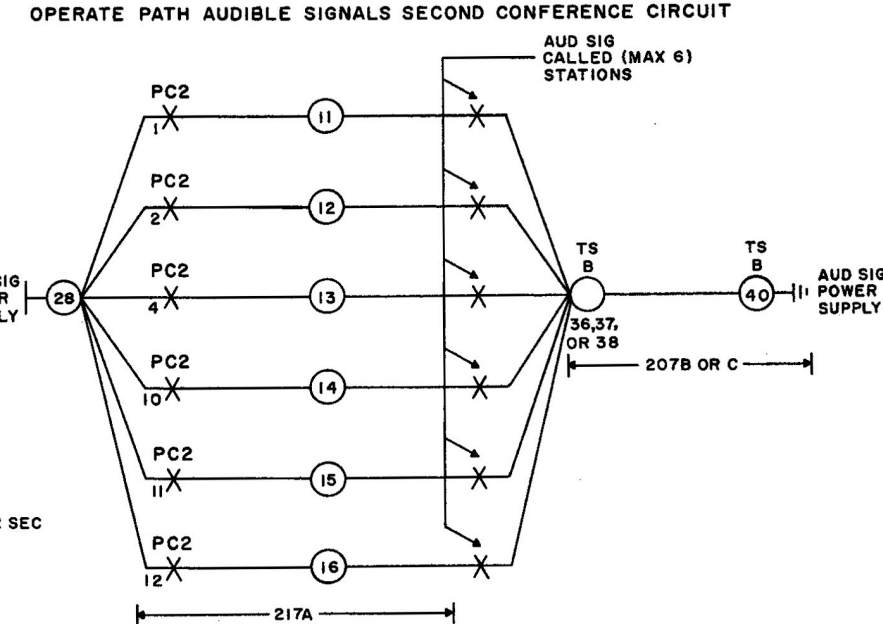
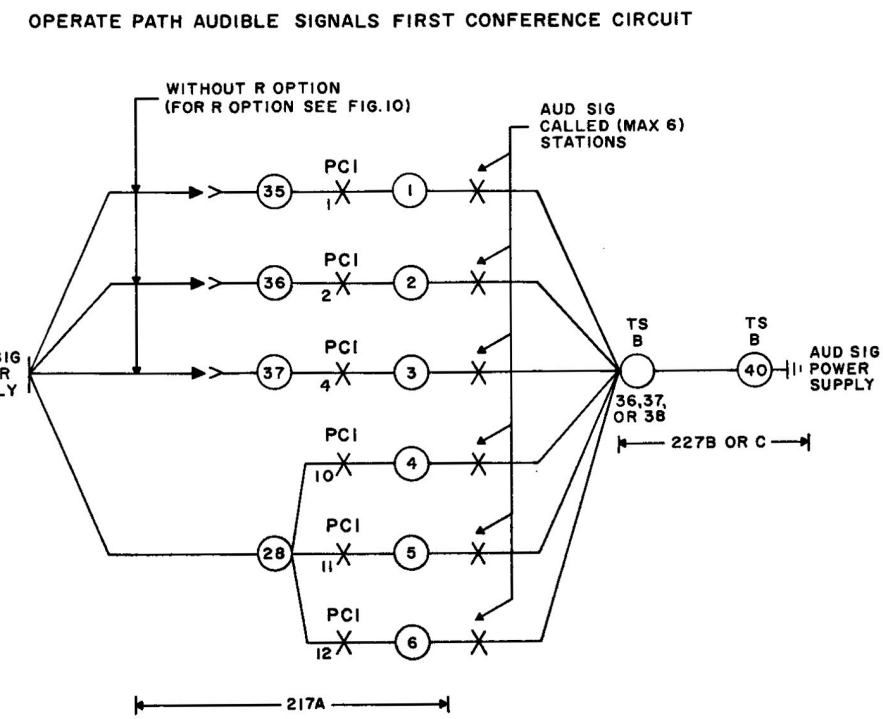
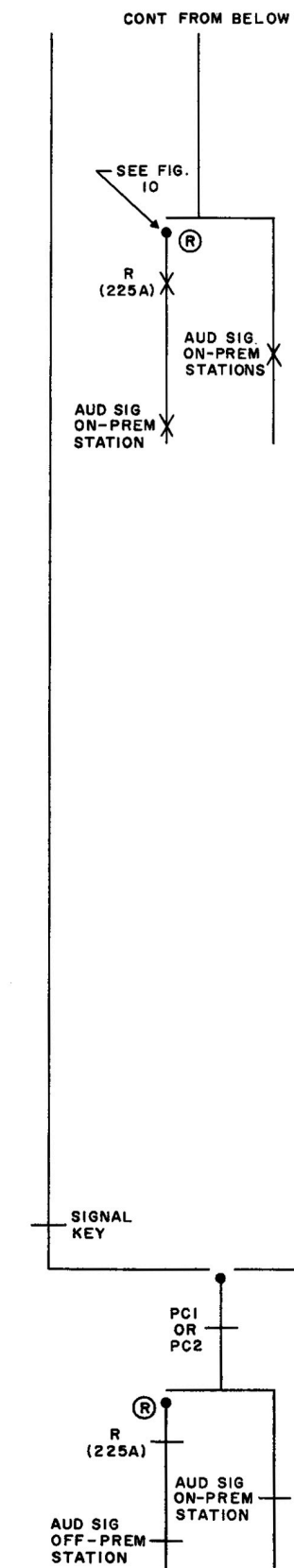
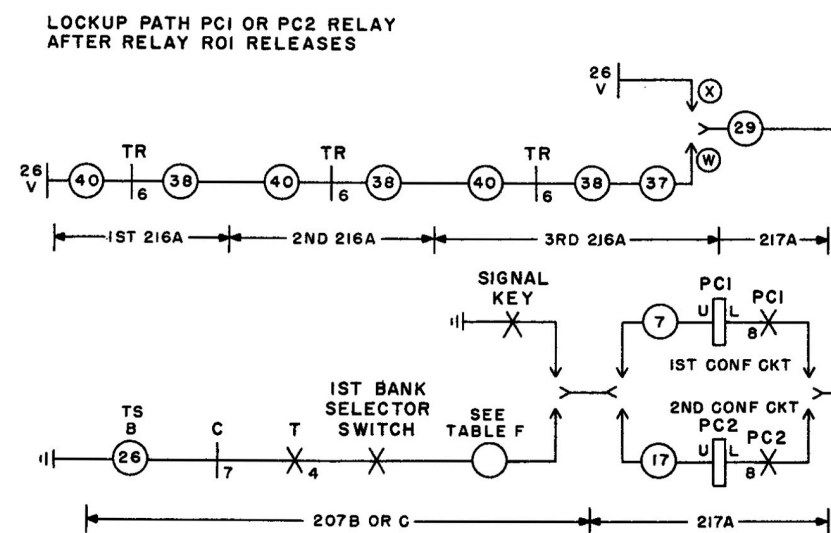
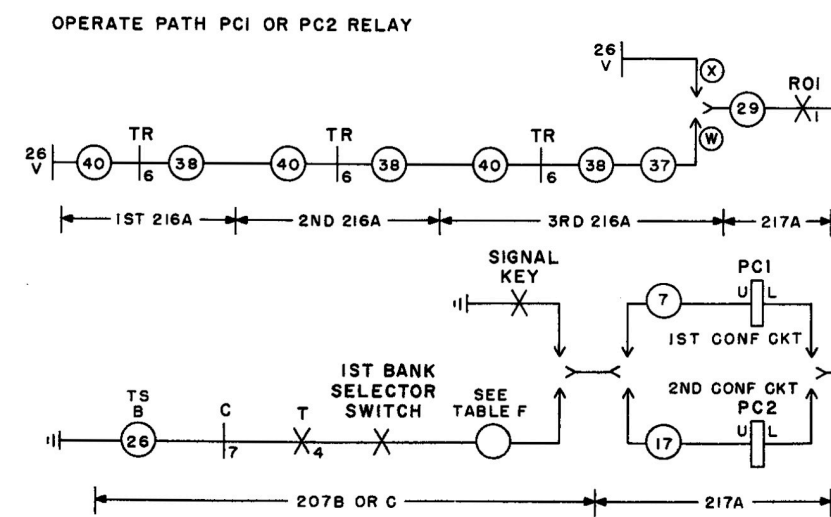
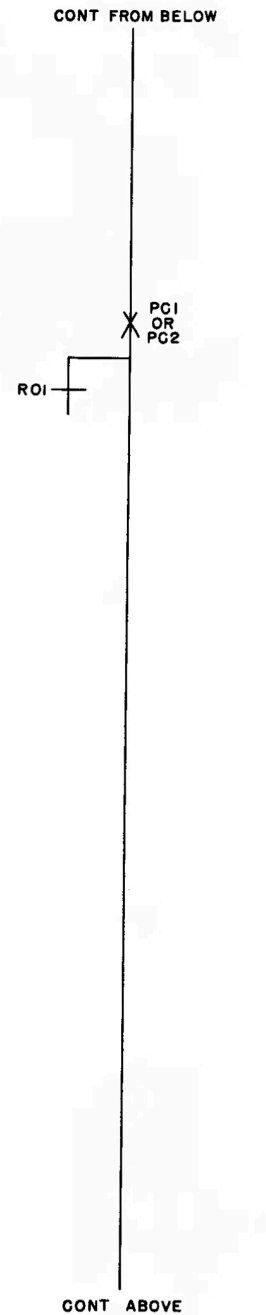
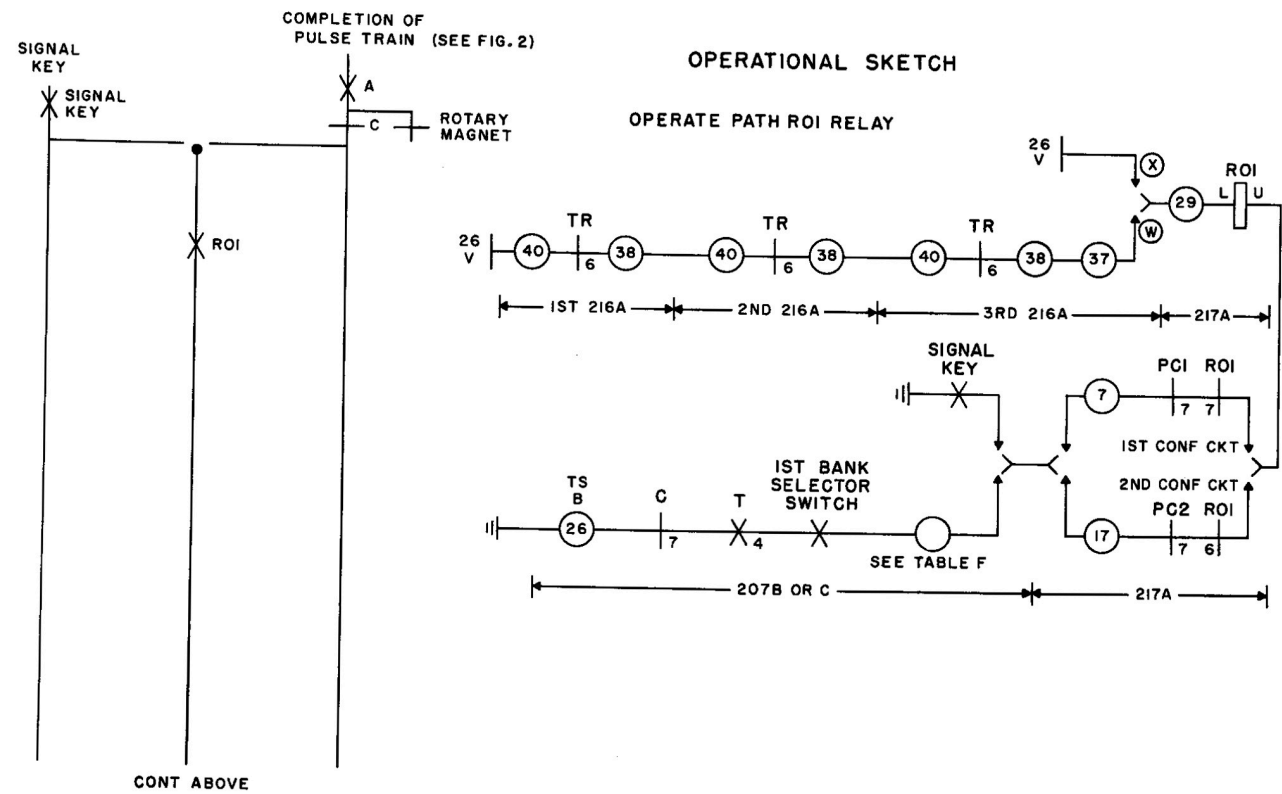

TABLE F
207B OR C

LEAD	TERMINAL
C	2A
C	3A
C	4A
C	5A
C	6A
C	7A
C	8A
C	9A
C	10A

Fig. 7 - Preset Conference

12.00 ADD-ON CONFERENCING

12.01 The incoming central office or PBX line is picked up under control of an associated key telephone system or key equipment line circuit. When it is ascertained that one of the 6A stations is to be conferenced with this call, a hold is placed on the central office or PBX line.

12.02 The 6A station to be conferenced is selected, signaled, and a talking path established as previously described.

12.03 The operation of the add-on signal key at the control station causes the operation of relay *N*. The *N* relay in operating: (a) locks up under control of the selector circuit, (b) opens

the operate path of any other *N* relay, thus preventing the interconnection of two or more outside lines (see inset on operational sketch), and (c) bridges the incoming central office or PBX line and the 6A station through the 120 *F* repeat coil.

12.04 The add-on conference control circuit is equipped with *A* lead control.

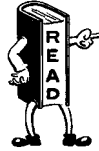

If an add-on signal key is accidentally operated, stations busy on the 6A line will be conferenced with the central office or PBX line.

Reference: SD-69286-01

SEQUENCE CHART

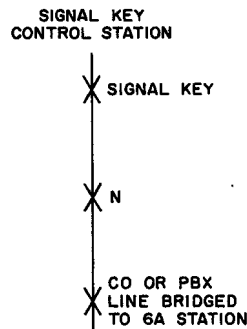

OPERATIONAL SKETCH

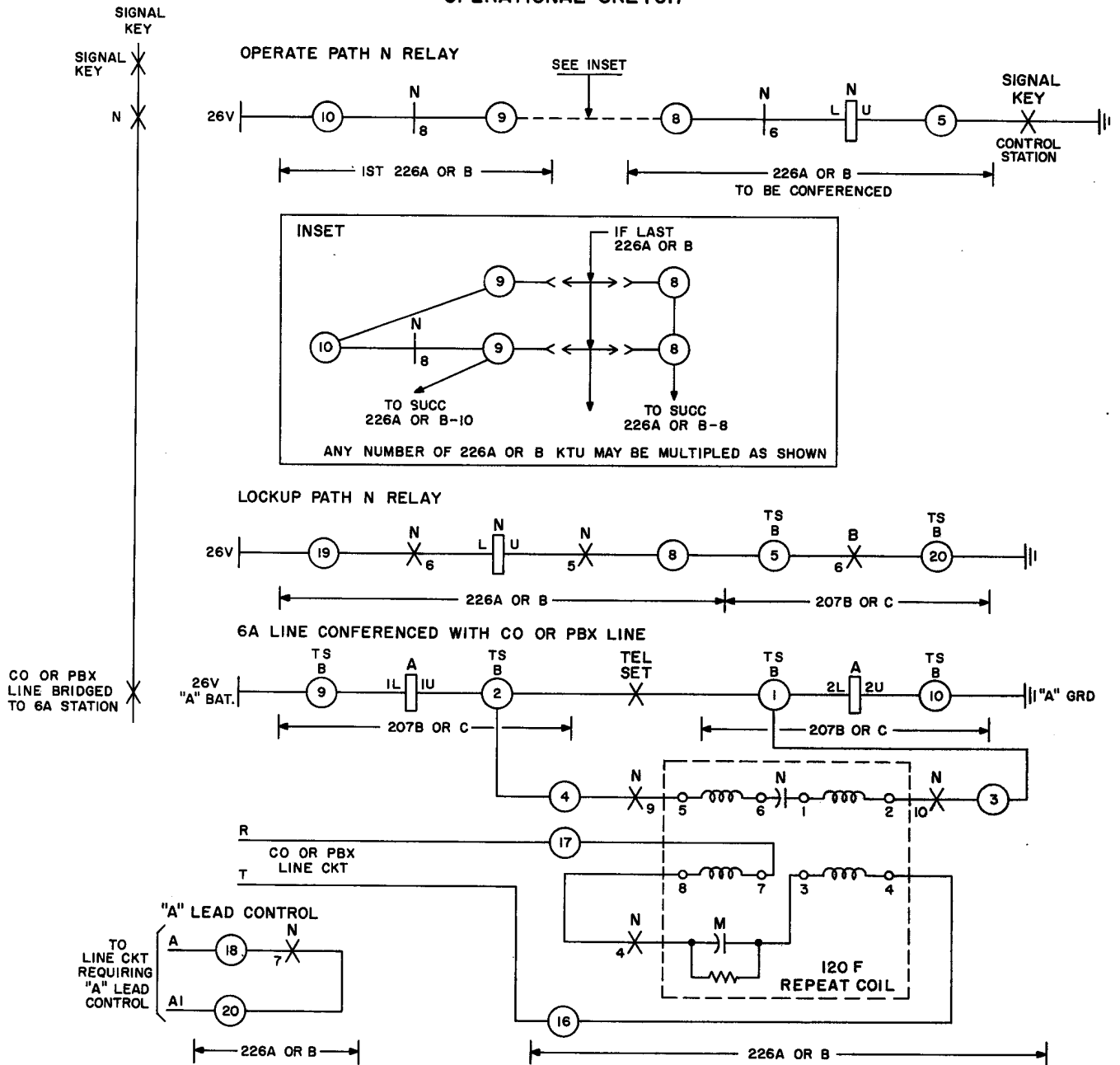
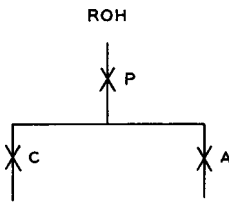

Fig. 8 - Add-On Conferencing

SEQUENCE CHART



13.00 OFF-PREMISE STATION, LINE SEIZURE

When an off-premise station initiates a call, it is connected to the selector circuit under control of the *P* relay in the long line circuit. As the station picks up, relay *P* operates and closes a path through the windings of the *C* relay in the long line circuit to operate the *A* relay in the selector circuit. Upon dialing, relay *P* repeats dial pulses causing relay *A* to release and reoperate in unison with the dial pulses. This action causes the selector circuit to operate as described in 4.00, 5.00, and 6.00.

Reference: SD-69286-01

OPERATIONAL SKETCH

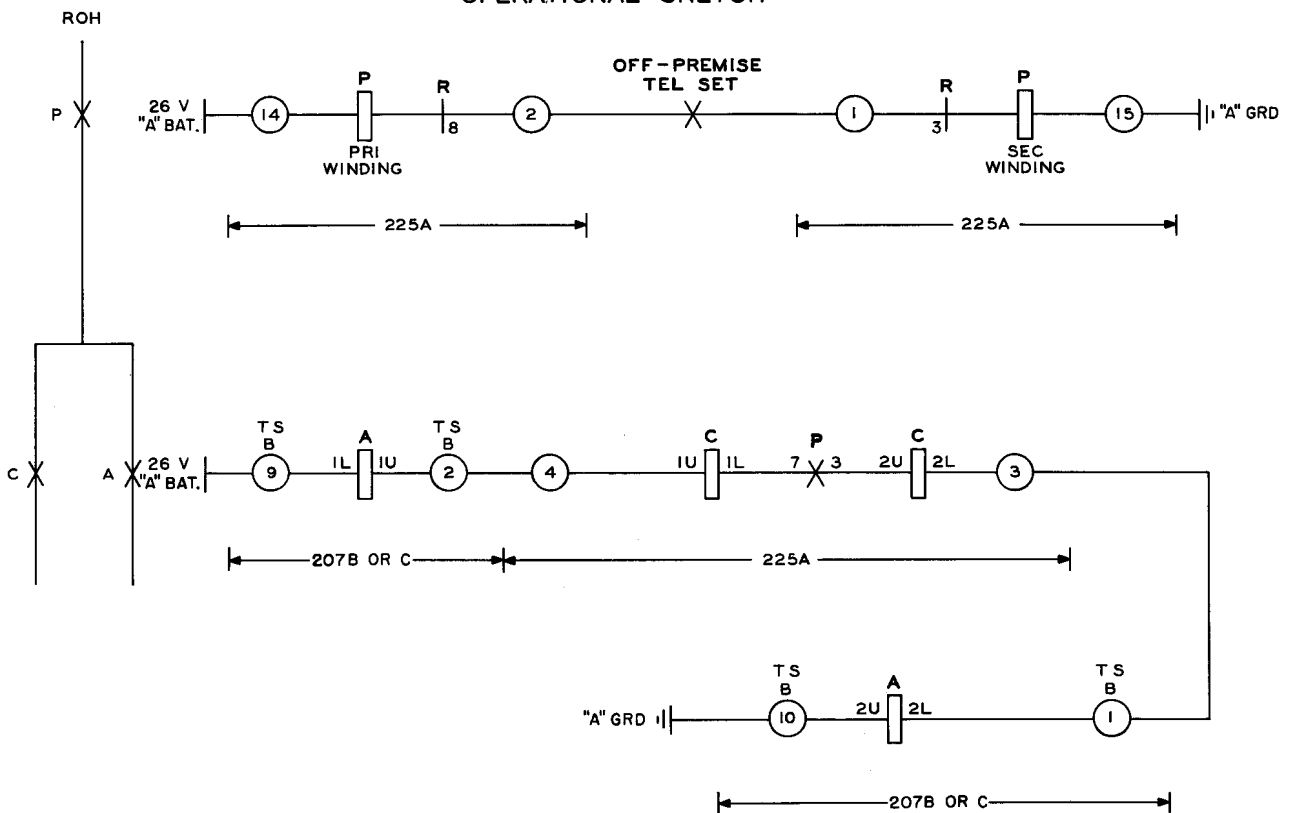

Fig. 9 - Off-Premise Station, Line Seizure

14.00 OFF-PREMISE STATION, INCOMING CALL

14.01 When an off-premise station is selected in the usual manner (by use of dial or signal key), the *C* or *S* lead ground causes operation of relay *R* in the long line circuit. The *R* relay: (a) opens the transmission path between the off-premise and local stations and (b) connects generator to the off-premise station's *T* and *R* leads operating the audible signal.

14.02 An off-premise station which is included in a preset conference arrangement has its long line circuit operated by a ground provided from the operated *PC1* relay in the preset conference circuit.

14.03 The *R* relay will release under control of the slow release *T* relay in the selector circuit, or upon release of the signal key, re-establishing the transmission path of the off-premise station.

Reference: SD-69286-01

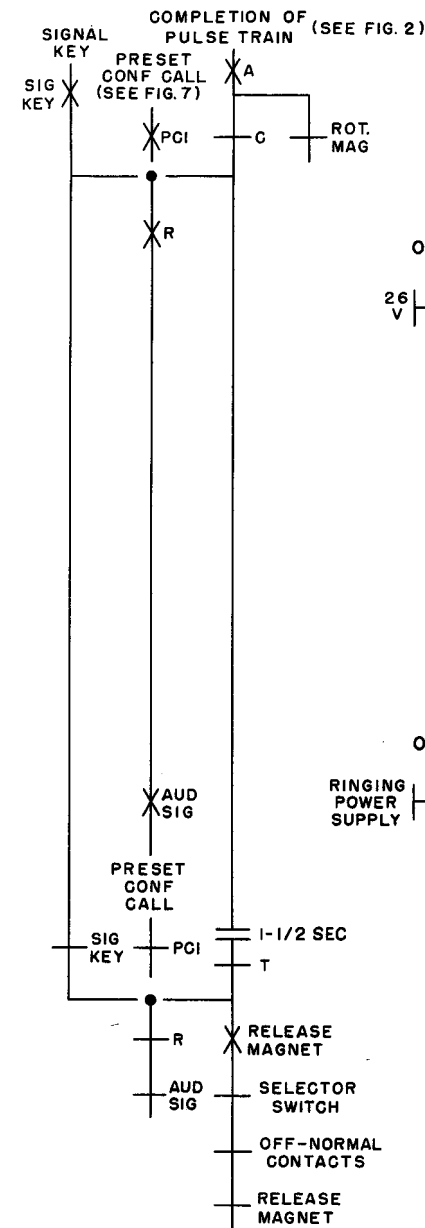
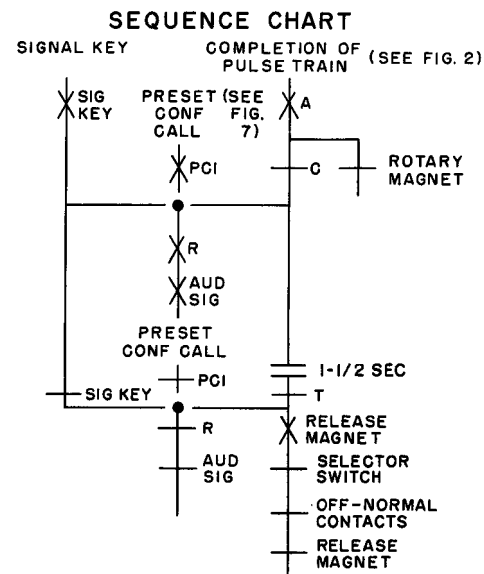

OPERATIONAL SKETCH

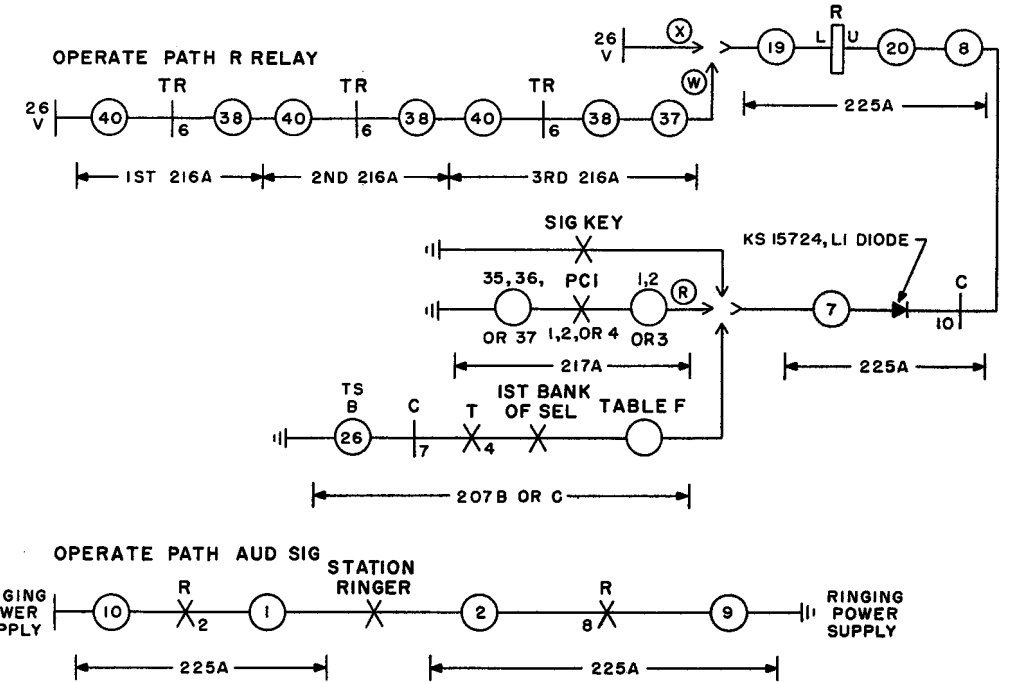

TABLE F

LEAD	TERMINAL
207B OR C KTU	
C	2A
C	3A
C	4A
C	5A
C	6A
C	7A
C	8A
C	9A
C	10A

Fig 10 — Off-Premise Station, Incoming Call

15.00 OFF-PREMISE STATION, ANSWERING INCOMING CALL

When an off-premise station picks up in response to an audible signal, the P relay will operate causing operation of relay C in the long line circuit. Relay C in operating opens the audible signal path for the off-premise station. Talking battery is supplied to the calling station from the A relay and to the off-premise station from the P relay.

SEQUENCE CHART

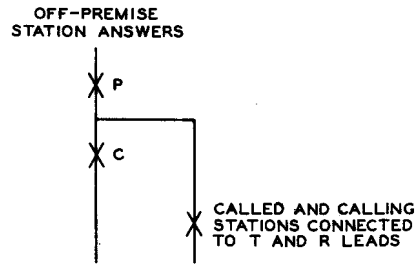

OPERATIONAL SKETCH

Reference: SD-69286-01

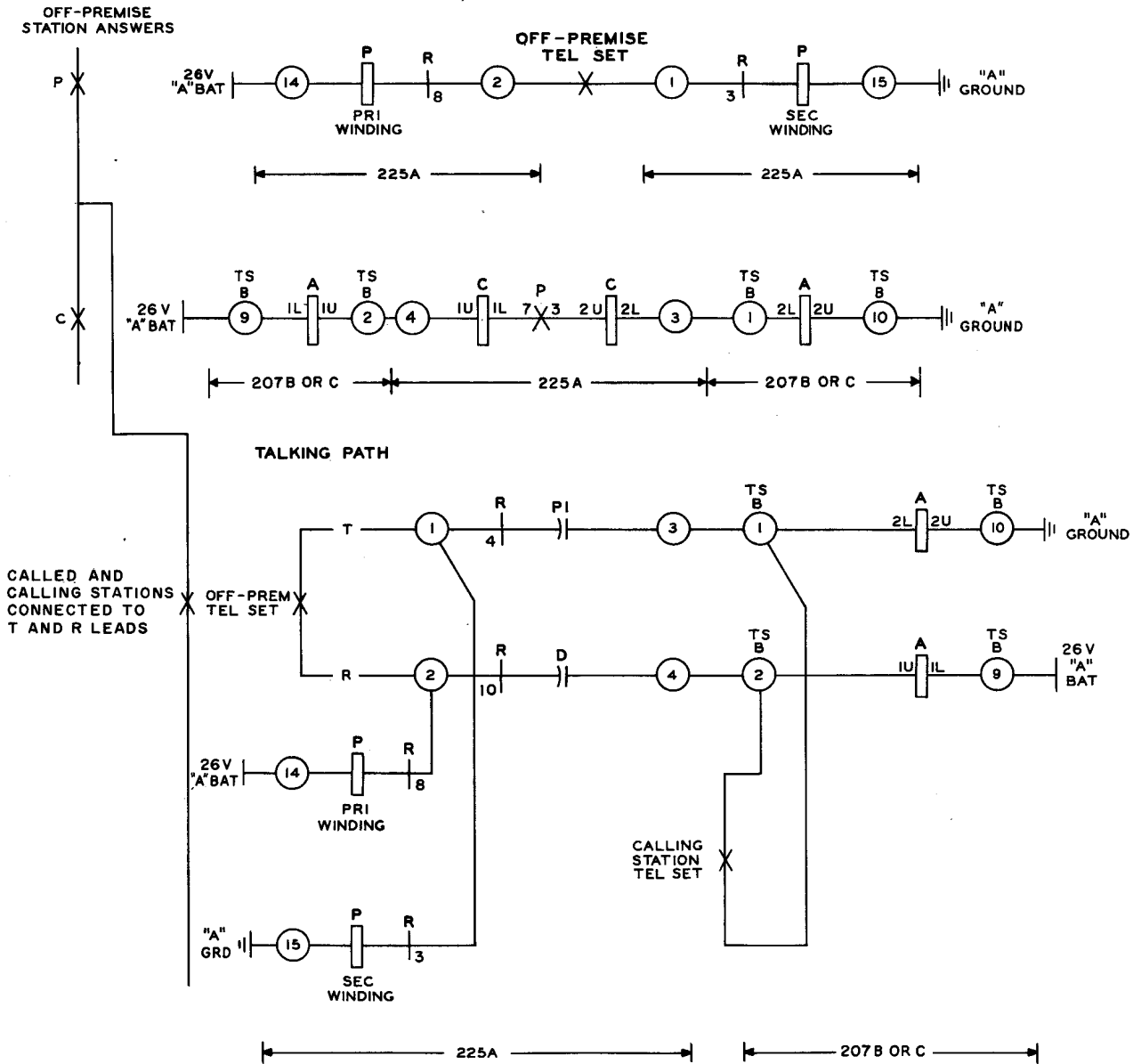

Fig. 11 - Off-Premise Station, Answering Incoming Call