

1A1 KEY TELEPHONE SYSTEM
LAMP WINK CIRCUIT
USING 202A, B, C, D; 230A, B; WITH 209A AND
210A KEY TELEPHONE UNITS
CONNECTIONS

1.00 GENERAL

1.01 This section covers connections required at the apparatus cabinet for the lamp wink circuit. This includes strapping between the key telephone units and termination of wires from power sources.

1.02 This section is reissued to include connections for 202C, 202D, 230A, and 230B key telephone units. Due to extensive changes, marginal arrows have been omitted.

1.03 The data shown in this section at the time of its issuance reflects the latest wiring connection arrangements. In some cases these connections are not consistent with those shown on existing drawings.

2.00 INDEX FOR CONNECTION FIGURES

Fig. 1 — 202A or 202B, with 209A and 210A Key Telephone Units, Lamp Winking Circuits

Fig. 2 — 202A or 202B, with 209A and 210A Key Telephone Units, Connections

Fig. 3 — 202C or 230A, with 209A and 210A Key Telephone Units, Lamp Winking Circuits

Fig. 4 — 202C, with 209A and 210A Key Telephone Units, Connections

Fig. 5 — 230A, with 209A and 210A Key Telephone Units, Connections

Fig. 6 — 202D or 230B, with 209A and 210A Key Telephone Units, Lamp Winking Circuits

Fig. 7 — 202D, with 209A and 210A Key Telephone Units, Connections

Fig. 8 — 230B, with 209A and 210A Key Telephone Units, Connections

3.00 DESCRIPTION OF OPERATION

Lamp Wink Circuit: When a line is held, ground is placed on the *HA* lead, operating the *WS* relay, and the signal lamp is connected to the *W* relay. Operation of the *WS* relay starts the flashing circuit and connects ground to a contact of the *FB* relay. When the *FB* relay operates, it operates the *W* relay under control of the *WT* relay. Operation of the *W* relay extinguishes the lamps and operates the *WT* relay. The *WT* relay locks operated under control of the *FB* relay and releases the *W* relay, which lights the lamps again. When the *FB* relay releases, it releases the *WT* relay, and the cycle repeats for each operation of the *FB* relay. The lamp circuit is opened for approximately 30 milliseconds once per second.

REFERENCES:

SD-69288-01

SD-69203-01

SD-69270-01

SECTION C71.343

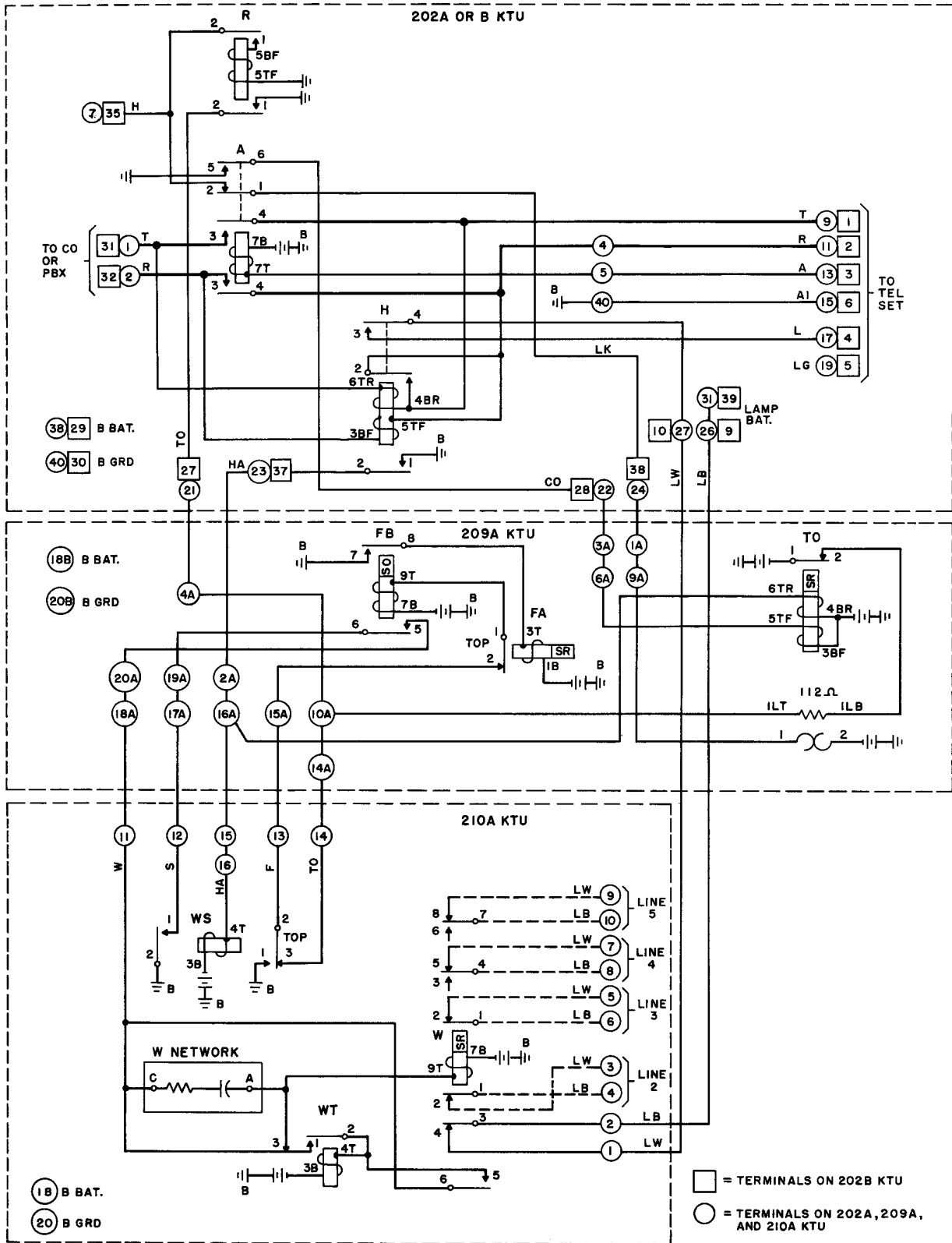

Fig. 1 — 202A or 202B, with 209A and 210A Key Telephone Units, Lamp Winking Circuits

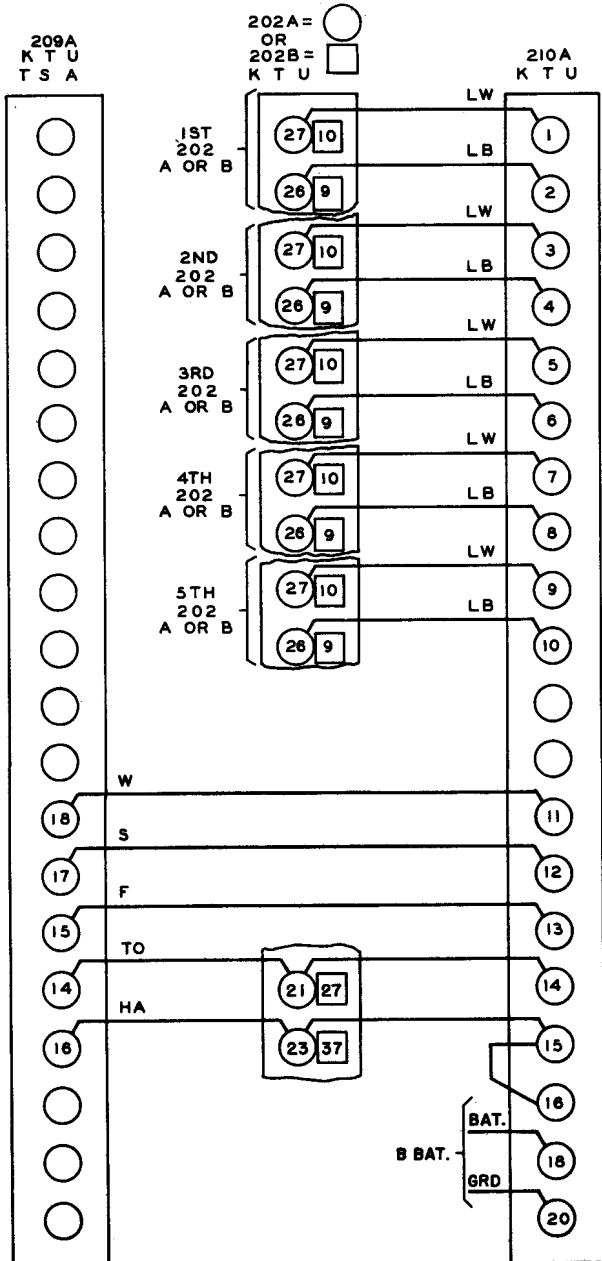

Fig. 2 — 202A or 202B, with 209A and 210A Key Telephone Units, Connections

Note 1: All straps shown shall be added to obtain features desired.

Note 2: Wink circuit for sixth line not provided unless second 210A KTU is provided.

Note 3: Remove the following Z wiring straps if in place:

202A KTU — Term. 26-27

202B KTU — Term. 9-10

209A KTU — Term. 14A-15A

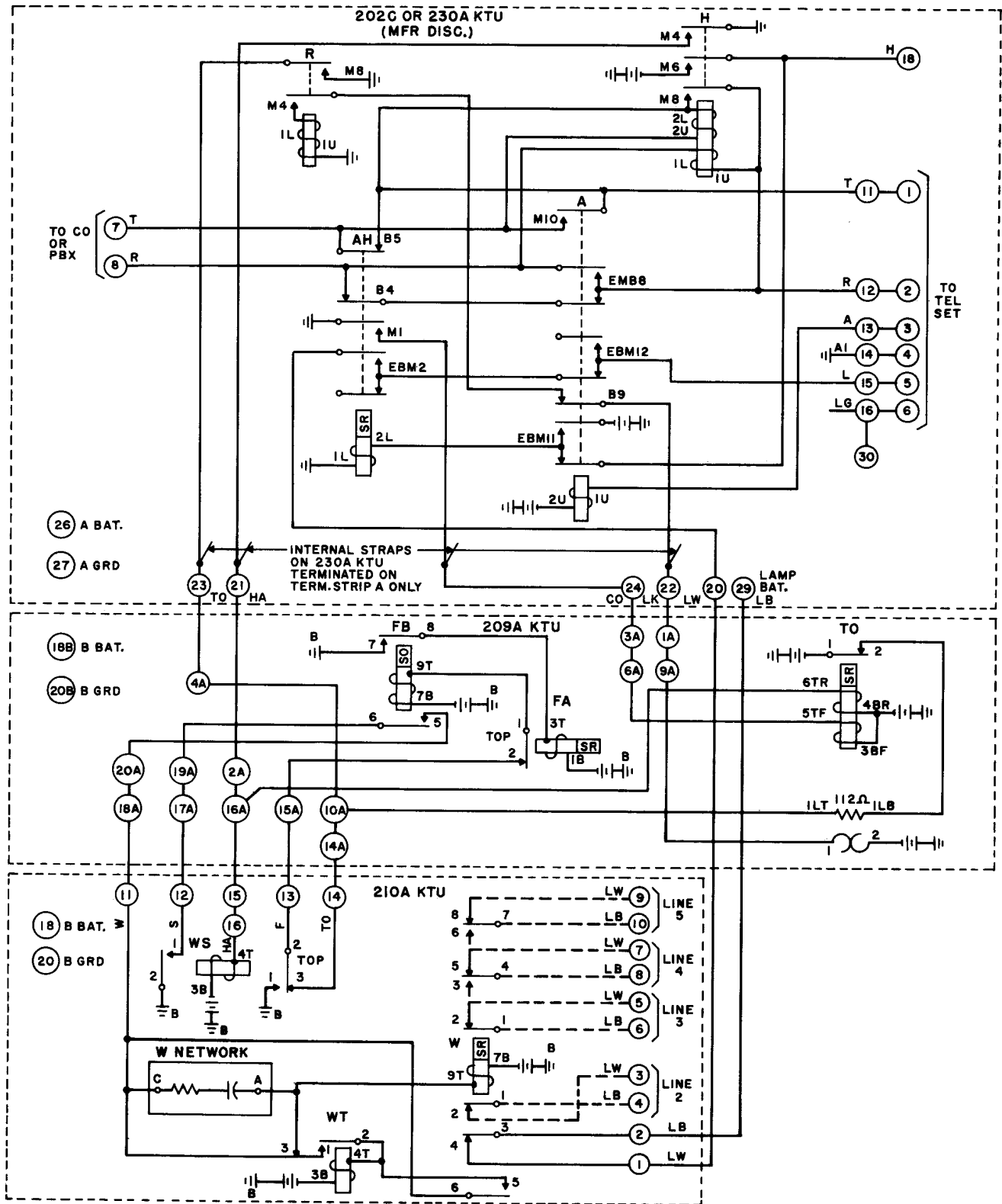

Fig. 3 - 202C or 230A, with 209A and 210A Key Telephone Units, Lamp Winking Circuits

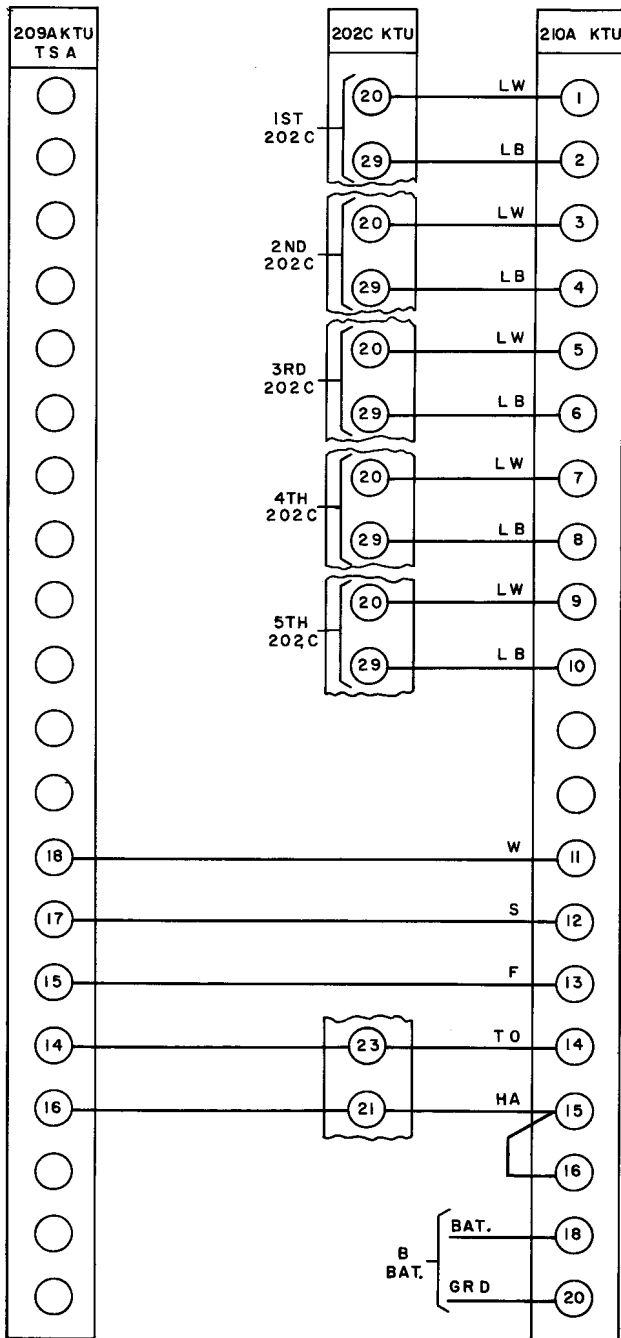

Fig. 4 – 202C, with 209A and 210A Key Telephone Units, Connections

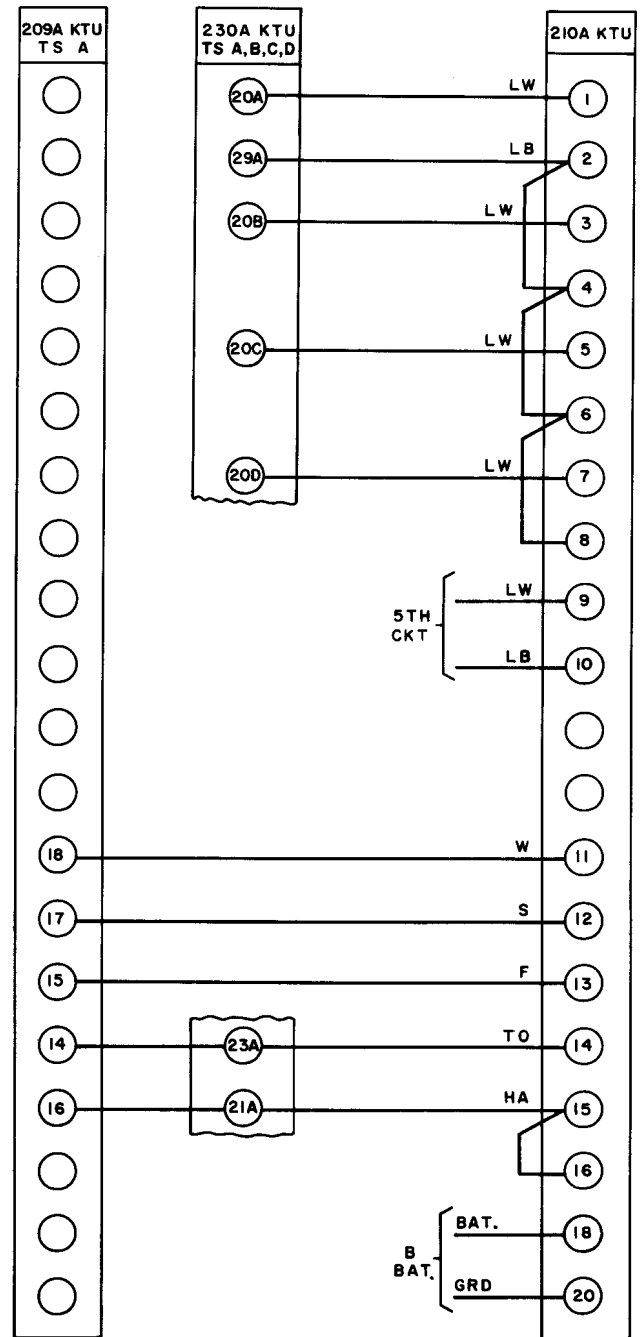

Fig. 5 – 230A, with 209A and 210A Key Telephone Units, Connections

Note 1: All straps shown shall be added to obtain features desired.

Note 2: Wink circuit for sixth line not provided unless second 210A KTU is provided.

Note 3: Remove the following straps if in place:

- 202C KTU — Term. 20
 - 230A KTU — Term. 20A, B, C, and D
 - 209A KTU — Term. 14A-15A
- } Disconnect Lamp Battery

Note 4: Terminals 21 through 30 appear on TSA only of 230A KTU.

SECTION C71.343

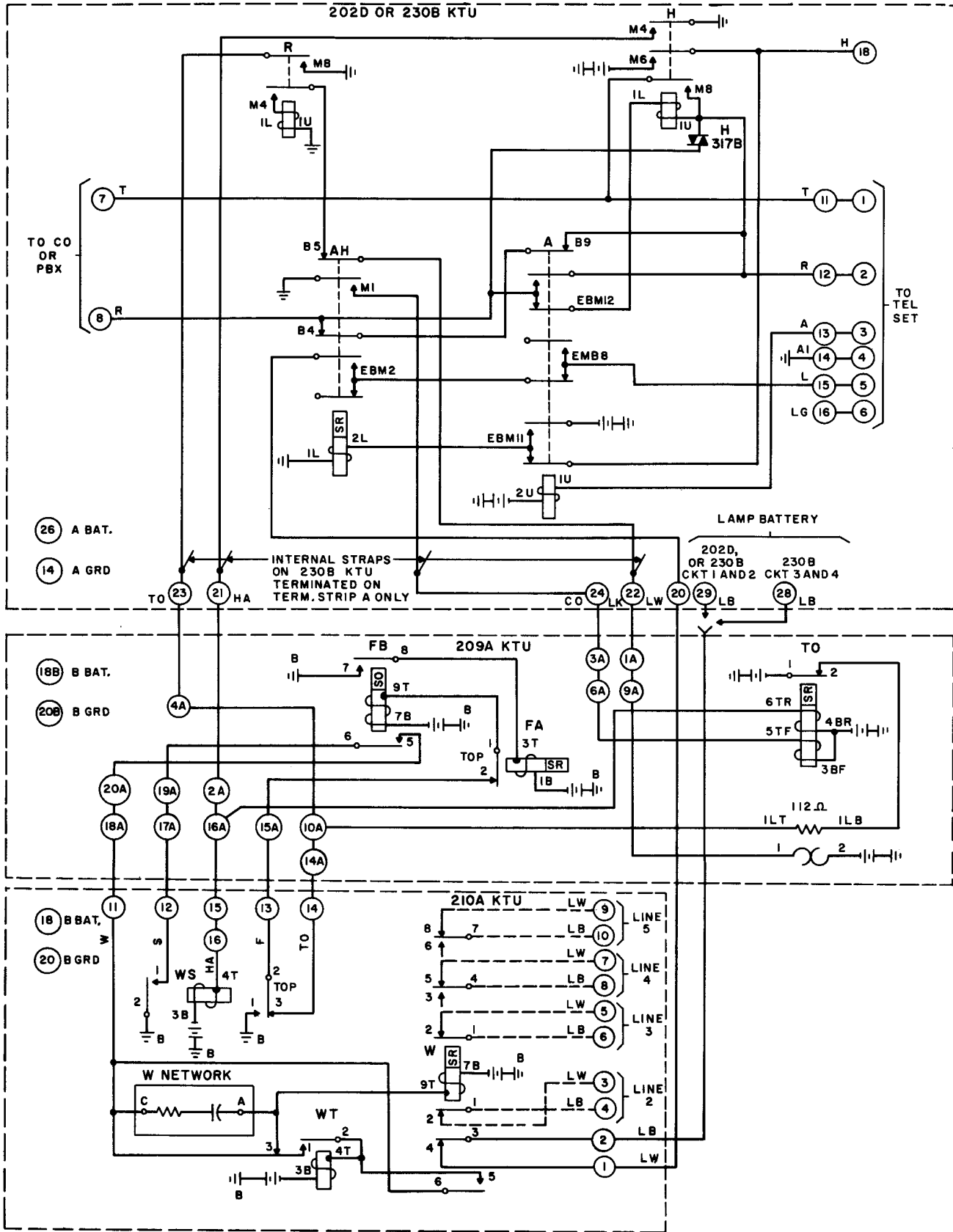

Fig. 6 - 202D or 230B, with 209A and 210A Key Telephone Units, Lamp Winking Circuits

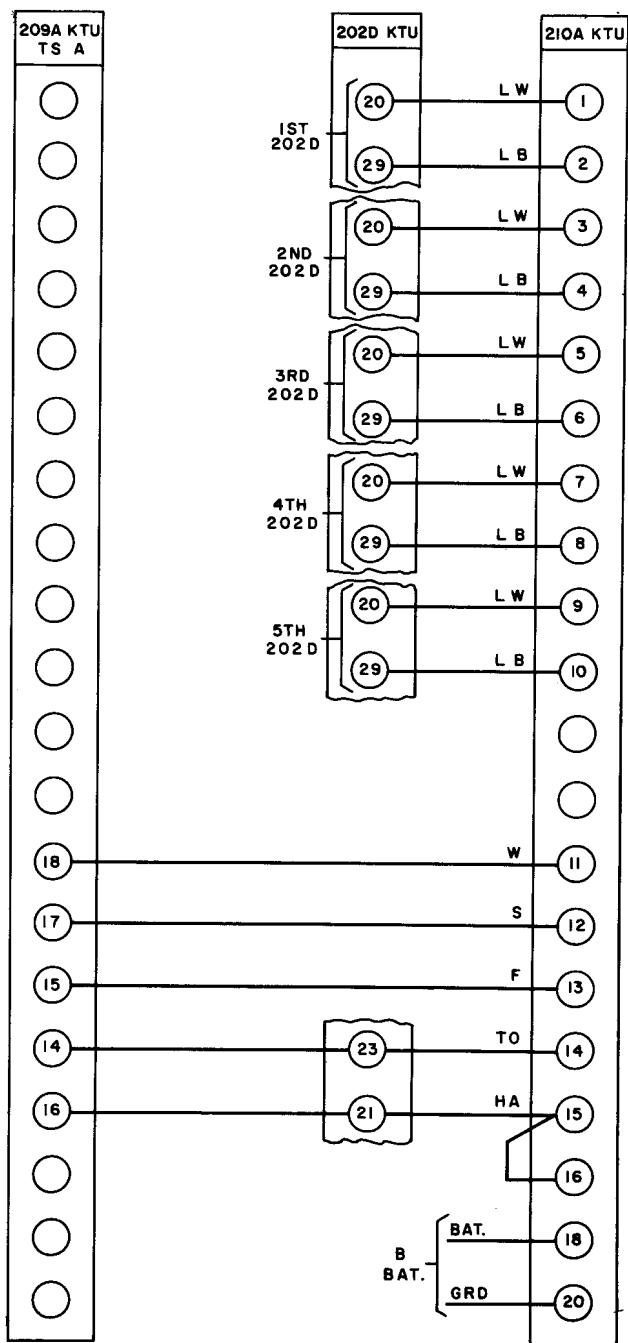

Fig. 7 — 202D, with 209A and 210A Key Telephone Units, Connections

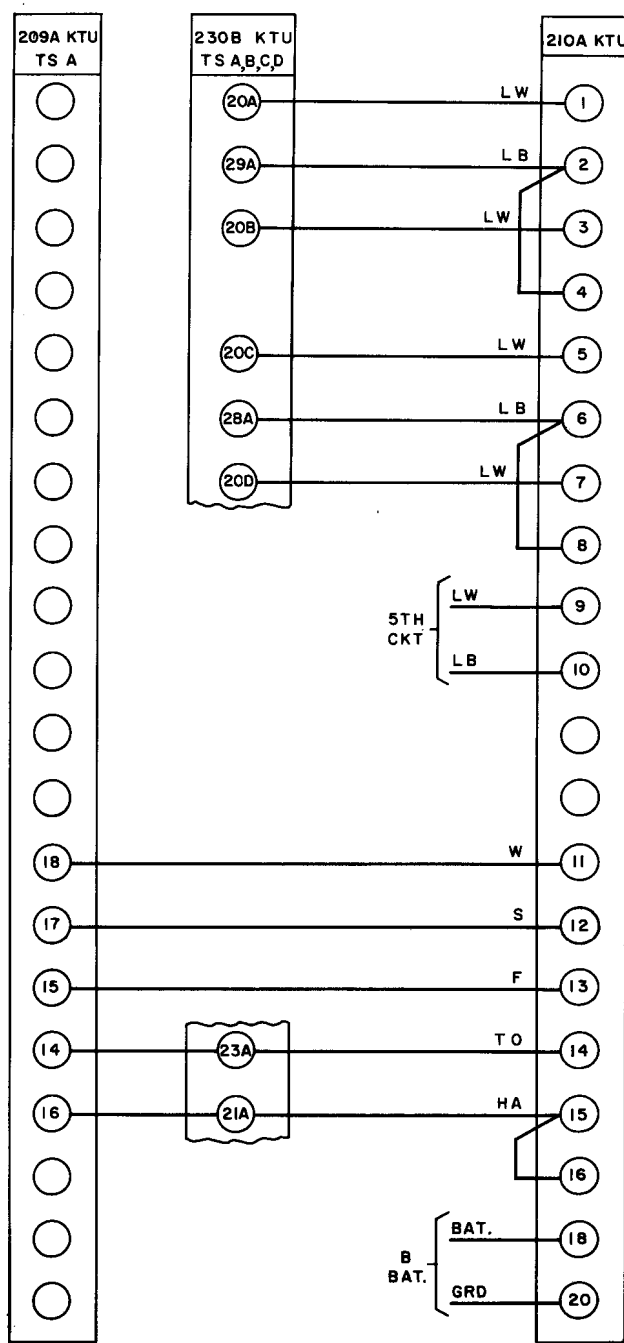

Fig. 8 — 230B, with 209A and 210A Key Telephone Units, Connections

Note 1: All straps shown shall be added to obtain features desired.

Note 2: Wink circuit for sixth line not provided unless second 210A KTU is provided.

Note 3: Remove the following straps if in place:

202D KTU — Term. 20

230B KTU — Term. 20A, B, C, and D

209A KTU — Term. 14A-15A

} Disconnect Lamp Battery

Note 4: Terminals 21 through 30 appear on TSA only of 230B KTU.