

1A1 KEY TELEPHONE SYSTEM
LAMP WINK CIRCUIT
USING 202A, B, C, D; WITH 210A AND
212A KEY TELEPHONE UNITS
CONNECTIONS

1.00 GENERAL

1.01 This section covers connections required at the apparatus cabinet for the lamp wink circuit. This includes strapping between the key telephone units and terminating of wires from power sources.

1.02 This section is reissued to include connections for 202C and D key telephone units.

1.03 The data shown in this section at the time of its issuance reflects the latest wiring connection arrangements. In some cases these connections are not consistent with those shown on existing drawings.

2.00 CONNECTIONS

2.01 Fig. 1 is a feature circuit drawing which supplements Fig. 2, a connection drawing. Fig. 1 has been included as an aid for clearing cases of trouble which might be encountered.

2.02 The connection drawing shows the necessary terminations to be made for power and cross-connection straps within and between key telephone units (see Fig. 2).

3.00 DESCRIPTION OF OPERATION

Lamp Wink Circuit: When a line is held, ground is placed on the *HA* lead, operating the *WS* relay, and the signal lamp is connected to the *W* relay. Operation of the *WS* relay starts the flashing circuit and connects ground to a contact of the *FB* relay. When the *FB* relay operates, it operates the *W* relay under control of the *WT* relay. Operation of the *W* relay extinguishes the lamps and operates the *WT* relay. The *WT* relay locks operated under control of the *FB* relay and releases the *W* relay, which lights the lamps again. When the *FB* relay releases, it releases the *WT* relay, and the cycle repeats for each operation of the *FB* relay. The lamp circuit is opened for approximately 30 milliseconds once per second.

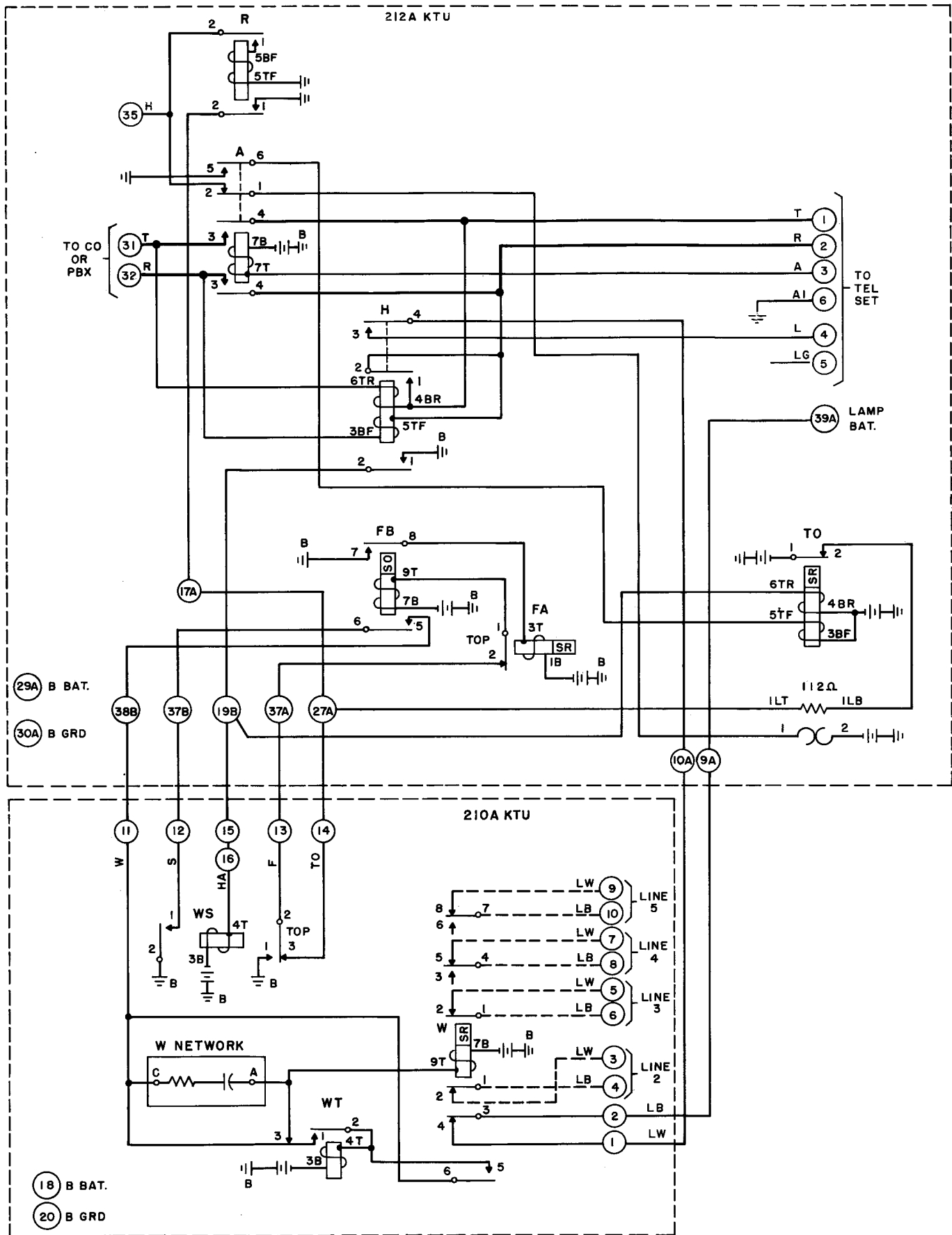
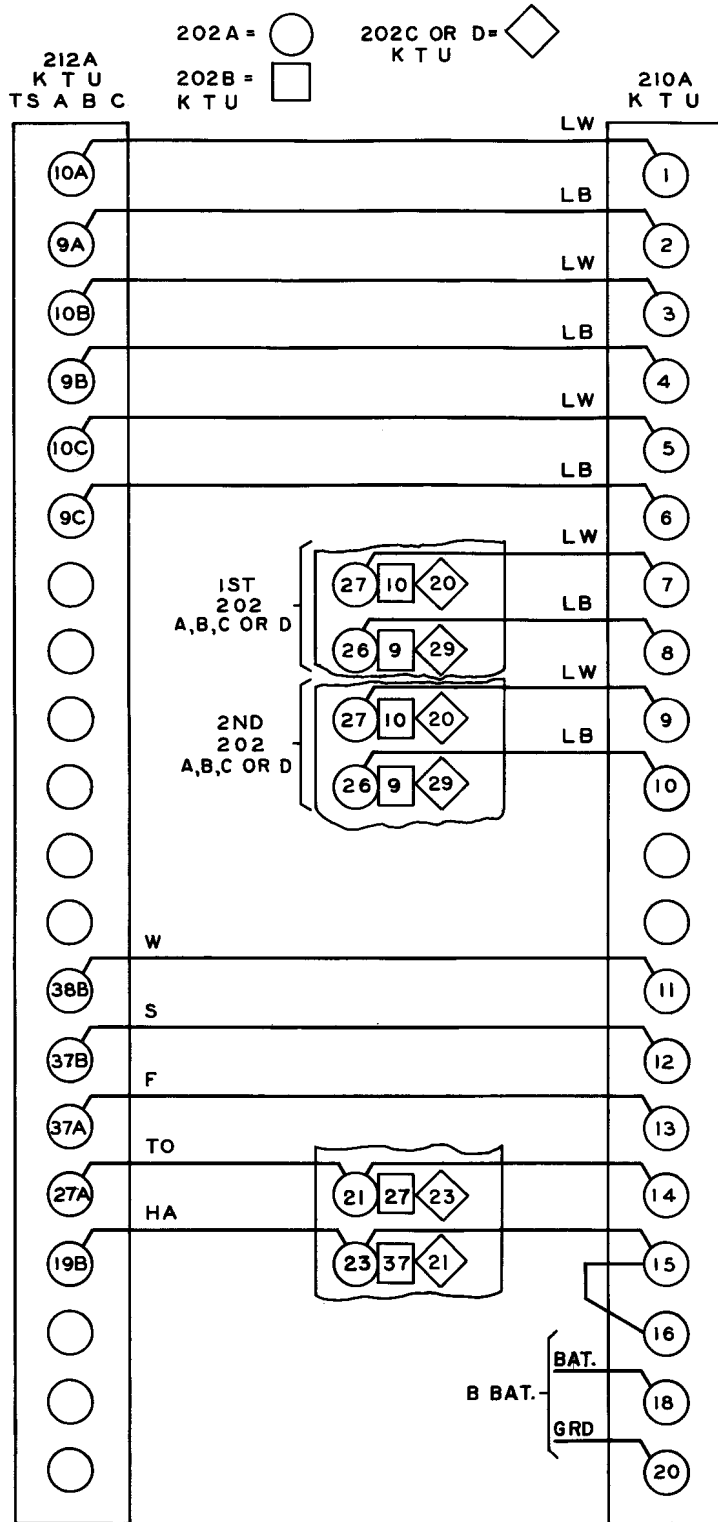

Fig. 1 - Lamp Wink Circuit - 210A and 212A Key Telephone Units



Note: Wink circuit for sixth line not provided unless second 210A KTU is provided.

Remove the following Z wiring straps if in place:

202A KTU — Term. 26-27

202B KTU — Term. 9-10

202C or D KTU — Term. 20 — Disconnect Lamp Battery

212A KTU — Term. 9-10, 27-37

References:

SD-69288-01

SD-69203-01

SD-69270-01

ALL STRAPS SHOWN SHALL BE ADDED TO OBTAIN FEATURES DESIRED.

Fig. 2 — Connections — 202A, B, C, D; with 210A and 212A Key Telephone Units