

**1A1 KEY TELEPHONE SYSTEM**  
**TIE AND STATION LINES**  
**203A AUTOMATIC TIE LINE UNIT, 204A RINGDOWN TIE LINE UNIT,**  
**205A STATION LINE UNIT**

**CONNECTIONS AND MAINTENANCE**

**1.00 GENERAL**

**1.01** This section covers connections at the apparatus cabinet for tie and/or station lines. This includes strapping between key telephone units, terminating of lines from feeder terminals, and terminating of key or running cables from key telephone stations.

**1.02** The data shown in this section at the time of its issuance reflect the latest wiring connection arrangements.

**1.03** This section is reissued to:

- Add *R* (KS-13490, List 3, 68-ohm) resistor to Fig. 2 to protect the *S* 317A varistor and *R* 400E diode from damage due to lightning surges.
- Add connections for the 232B KTU and the common equipment portion of the 238A KTU.
- Provide an arrangement for the tie and station line circuit drawings (203A, 204A, and 205A) to match common equipment circuit drawings (209A, 212A, 232B, and 238A).
  1. For maintenance, Fig. 1, 2, or 3 matches Fig. 6 or 7.
- Show typical connections for audible signal arrangements (Fig. 4 and 5).

**1.04** Index of Figures

**Circuit Drawings**

- Fig. 1 - 203A KTU, Automatic Tie Line Circuit
- Fig. 2 - 204A KTU, Ringdown Tie Line Circuit
- Fig. 3 - 205A KTU, Station Line Circuit
- Fig. 6 - Common Equipment, 209A or 212A KTU
- Fig. 7 - Common Equipment, 232B or 238A KTU

**Connection Drawings**

- Fig. 4 - Typical Connections for Operating a Common Audible Signal Controlled by

a 16A or 211A KTU (This Circuit Provides a Steady Audible Signal.)

Fig. 5 - Typical Connections for Operating a Common Audible Signal Controlled by a 227A and 232B or 238A KTU (This Circuit Provides an Interrupted Audible Signal.)

Fig. 8 - 203A, 204A, or 205A KTU Connections to Common Equipment (209A, 212A, 232B, or 238A KTU)

**1.05** Due to extensive changes, marginal arrows have been omitted.

**2.00 CONNECTIONS**

The connection drawing shows the necessary terminations to be made for power, cross connection straps within and between key telephone units, and terminations of key or running cable from telephone sets (see Fig. 8).

**3.00 MAINTENANCE**

**3.01** Circuit drawings and a description of operation have been included as an aid for clearing cases of trouble which may be encountered.

**3.02** At the time of this issue, 204A key telephone units (Fig. 2) are being manufactured with the *R* (KS-13490, List 3, 68-ohm) resistor in series with the ringup circuit. The resistor will also be added to units processed by the distributing houses.

**3.03** The *R* resistor may be added to 204A key telephone units in the field when circumstances warrant. Be guided by local instructions. Proceed as follows:

1. Remove terminal backplate.
2. Remove strap between bottom terminal of *R*1 capacitor and bottom terminal of *R* capacitor.
3. Install resistor in place of strap.
4. Replace terminal backplate.

## 4.00 DESCRIPTION OF OPERATION

Automatic Tie Line Circuit (Fig. 1)

**4.01 Incoming Call** — Battery and ground, coming in over the line from similar equipment at the distant end, operate the *L* relay which in turn operates the *L1* relay. The *L1* relay closes the audible signal circuits to give a steady or interrupted audible signal, connects the signal lamp to the lamp flashing circuit, and starts the flashing and time-out circuit of Fig. 6 or Fig. 7 functioning.

**4.02 Answering an Incoming Call** — An incoming call is answered by operating the pickup key associated with the line being rung and removing the handset from its mounting. Current through the telephone set operates the *TB* relay, which releases the *L1* relay, operates the *TO* relay of Fig. 6 or Fig. 7, and operates the *CO* relay. This relay locks operated under parallel control of the *TB* and *L* relays and lights the signal lamps steadily. Release of the *L1* relay opens the audible signal circuits, disconnects the signal lamp from the flashing circuit, and stops the flashing circuit.

**4.03 Outgoing Call** — An outgoing call is originated by operating the pickup key associated with the line and removing the handset from the mounting. Current through the telephone set operates the *TB* relay, which in turn operates the *CO* and *L* relays and the *TO* relay of Fig. 6 or Fig. 7 and connects battery and ground to the ring and tip of the line, respectively, to operate the signal-

ing circuit at the distant end. The *CO* relay lights the signal lamp steadily and locks operated under parallel control of the *L* and *TB* relays. No change takes place in this circuit when the call is answered at the distant end.

**4.04 Holding** — The holding feature is not provided with this circuit; but if the local station disconnects and the distant station does not, the signal lamps will remain lighted steadily.

**4.05 Disconnection** — The *CO* relay remains operated until both the local and distant parties have disconnected, keeping the busy lamp lighted and preventing a false incoming signal. If the party at the distant end disconnects first, no change occurs in the local circuit until the local party disconnects. The *TB* relay then releases, which releases the *TO* relay of Fig. 6 or Fig. 7, opens the operating path of the *CO* relay, and removes battery and ground from the ring and tip of the line, respectively, and from the *L* relay. The *L* relay releases and in turn releases the *CO* relay, extinguishing the signal lamp and restoring the circuit to normal. If the local party disconnects first, the *TB* relay releases, opening the operating path for the *CO* relay, releasing the *TO* relay, and removing local battery and ground from the line. The *L* relay remains operated by current over the line from the distant station until that party disconnects, removing battery and ground from the line and releasing the *L* relay, which in turn releases the *CO* relay, extinguishing the signal lamp and restoring the circuit to normal.

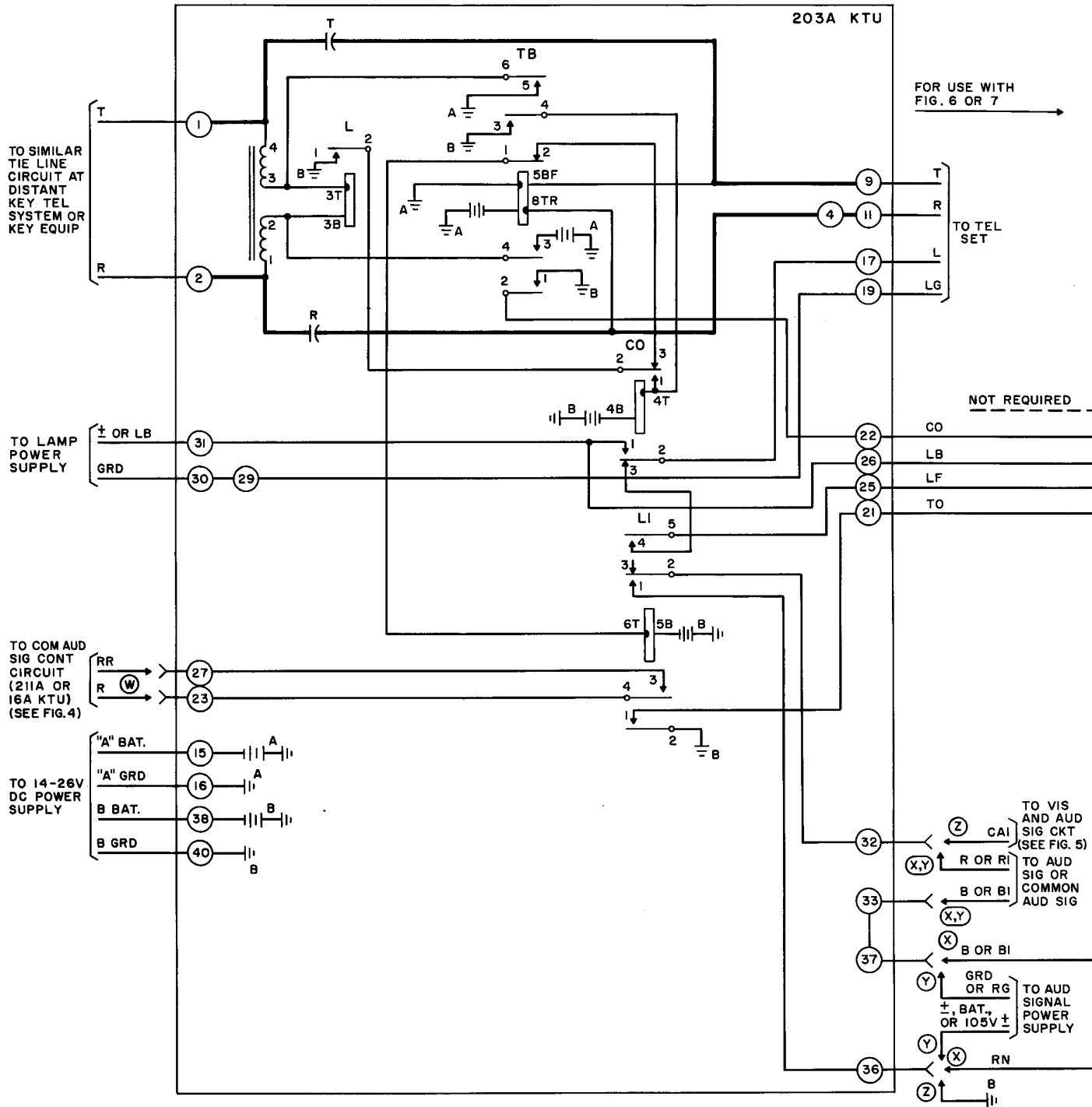

**OPTIONS:**

- Ⓜ Steady common audible signal using common audible signal control circuit (211A or 16A KTU).
- ⓧ Interrupted audible signal or common audible signal using electromechanical interrupter (232B or 238A KTU).
- Ⓜ Steady audible signal or common audible signal.
- Ⓜ Interrupted common audible signal using relay control circuit (227A and 232B or 238A KTU).

**Fig. 1 – 203A KTU, Automatic Tie Line Circuit**

**Ringdown Tie Line (Fig. 2)**

**4.06 Incoming Call** — A ringing signal into the tie line circuit flows through the *R* resistor, the *R1* capacitor, the *R* thermistor, and the *R* relay on one half of the cycle, and through the *R* diode shunted across the relay on the other half of the cycle. The cold resistance of the *R* thermistor initially is too high to permit operation of the relay, but the resistance is lowered by heating the ringing current until the relay operates after approximately 1/2 second of ringing. The *S* 317A varistor protects the *R* diode and the *R* thermistor from transients. The *R* resistor protects the *S* 317A varistor and the *R* diode from damage due to lightning surges (see 3.02, 3.03). The *R* relay closes the second common ringing circuit, which follows the incoming ringing and operates the *R1* relay. This relay locks operated under control of the *TB* relay and of the *TO* relay of Fig. 6 or Fig. 7. The *R1* relay closes the first common audible ringing circuit, which provides a steady or interrupted audible signal, connects the signal lamp to the flashing circuit, and starts the flashing and time-out circuit of Fig. 6 or Fig. 7 functioning.

**4.07 Answering an Incoming Call** — An incoming call is answered by operating the pickup key associated with the line being rung and removing the handset from the mounting. Current

through the telephone sets operates the *TB* relay which releases the *R1* relay, lights the signal lamp steadily, operates the *TO* relay of Fig. 6 or Fig. 7, and connects the talking circuit of the key telephone set to the line. Release of the *R1* relay silences the steady common audible signal and stops the lamp flashing circuit.

**4.08 Outgoing Call** — An outgoing call is originated by operating the pickup key associated with the line and removing the handset from the mounting. Current through the telephone set operates the *TB* relay which in turn operates the *TO* relay of Fig. 6 or Fig. 7, lights the signal lamps steadily, and connects the talking circuit of the key telephone set to the line. The local party signals the called station by operating the signaling key. This key operates the *RO* relay, which in turn connects ringing current to the line. No change takes place in the local circuit when the distant station is answered.

**4.09 Holding** — The holding feature is not provided with this circuit.

**4.10 Disconnection** — When the local station is disconnected, the *TB* relay releases, extinguishing the signal lamps, releasing the *TO* relay of Fig. 6 or Fig. 7, and restoring the circuit to normal.

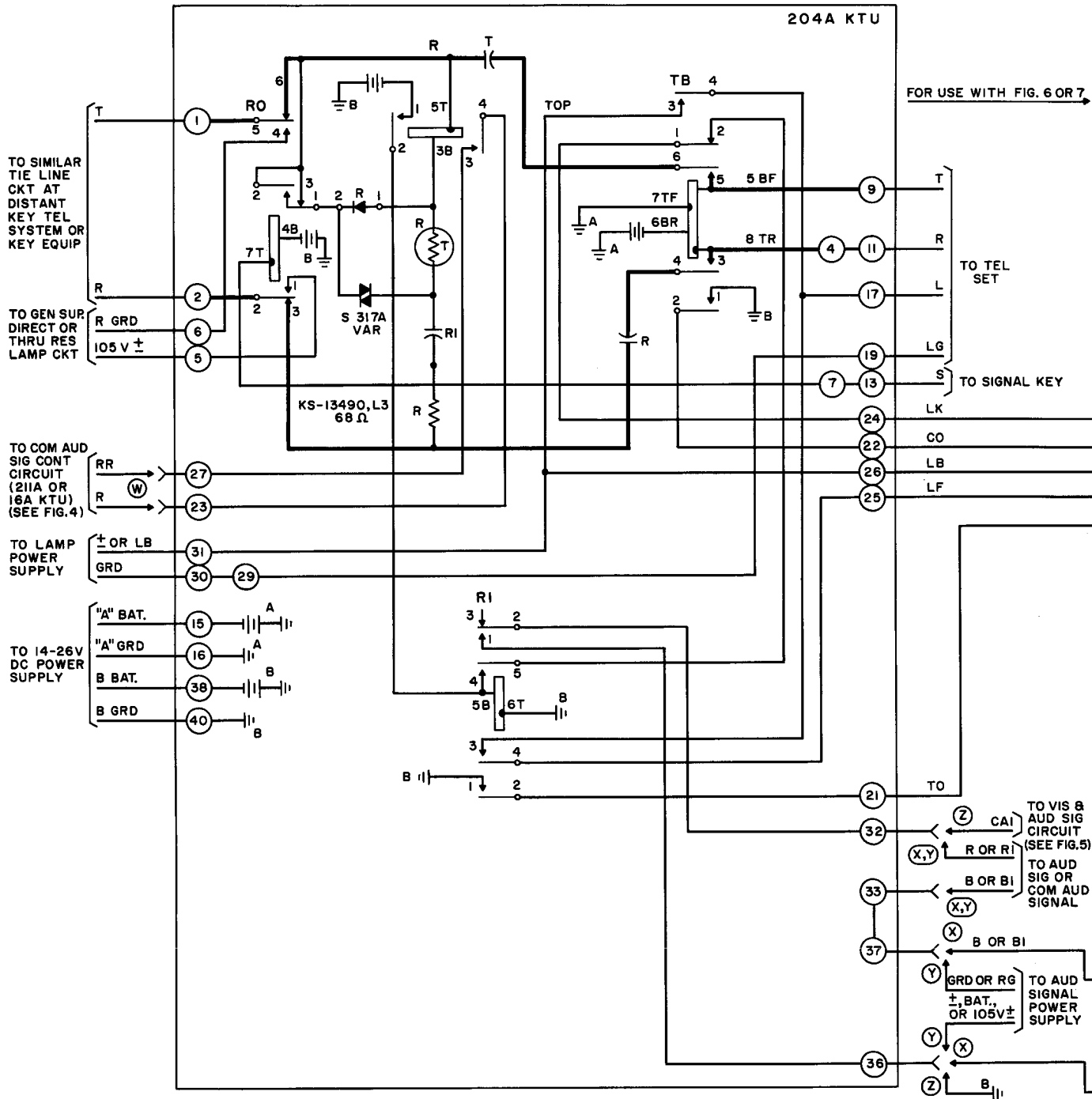

**OPTIONS:**

- Ⓜ Steady common audible signal using common audible signal control circuit (211A or 16A KTU).
- ⓧ Interrupted audible signal or common audible signal using electromechanical interrupter (232B or 238A KTU).
- Ⓨ Steady audible signal or common audible signal.
- Ⓩ Interrupted common audible signal using relay control circuit (227A and 232B or 238A KTU).

**Fig. 2 – 204A KTU, Ringdown Tie Line Circuit**

**Station Line Circuit (Fig. 3)**

**4.11 Incoming Call** — When a call is originated at the distant station, the *L* relay is operated by the set current and in turn operates the *L1* relay. The *L1* relay closes the audible signal circuits to give a steady or interrupted audible signal, connects the signal lamps to the flashing circuit, and starts the flashing circuit functioning of Fig. 6 or Fig. 7.

**4.12 Answer an Incoming Call** — An incoming call is answered by operating the pickup key associated with the line and removing the handset from the mounting. Current through the telephone set operates the *TB* relay, which releases the *L1* relay, operates the *CO* relay, and operates the *TO* relay of Fig. 6 or Fig. 7. The release of the *L1* relay silences the audible signals and stops the lamp flashing circuit functioning. Operation of the *CO* relay lights the signal lamps steadily and locks itself operated under control of the *L* relay in parallel with contacts of the *TB* relay.

**4.13 Outgoing Call** — An outgoing call is originated by operating the pickup key associated with the line, removing the handset from

the mounting, and operating the signaling key. Current through the telephone set operates the *TB* relay, which operates the *TO* relay of Fig. 6 or Fig. 7 and operates the *CO* relay, which in turn lights the signal lamps steadily. Operation of the signaling key operates the *RO* relay which connects ringing current to the line to signal the distant station. When the distant station is answered, the set current operates the *L* relay which locks the *CO* relay operated.

**4.14 Holding** — The holding feature is not provided with this circuit, although if the local station disconnects and the distant station does not, the signal lamps will remain lighted steadily and no incoming signals will be operated due to the parallel holding paths which keep the *CO* relay operated.

**4.15 Disconnection** — When the distant station is disconnected, the *L* relay releases. When the local station is disconnected, the *TB* relay is released, releasing the *TO* relay of Fig. 6 or Fig. 7. The last station disconnected releases the *CO* relay which extinguishes the signal lamp and restores the circuit to normal.

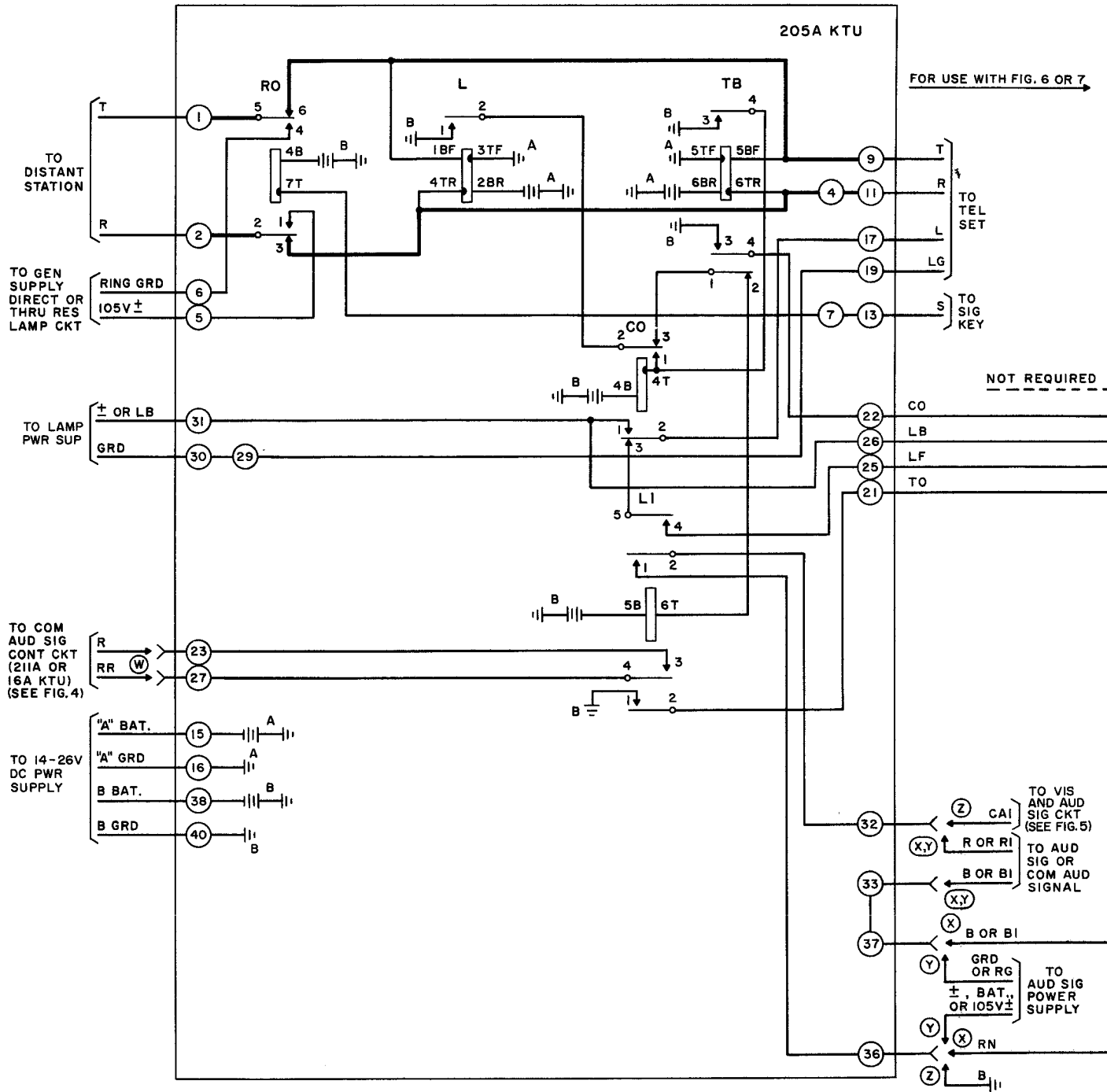

**OPTIONS:**

- Ⓜ Steady common audible signal using common audible signal control circuit (211A or 16A KTU).
- ⓧ Interrupted audible signal or common audible signal using electromechanical interrupter (232B or 238A KTU).
- Ⓢ Steady audible signal or common audible signal.
- Ⓣ Interrupted common audible signal using relay control circuit (227A and 232B or 238A KTU).

**Fig. 3 – 205A KTU, Station Line Circuit**

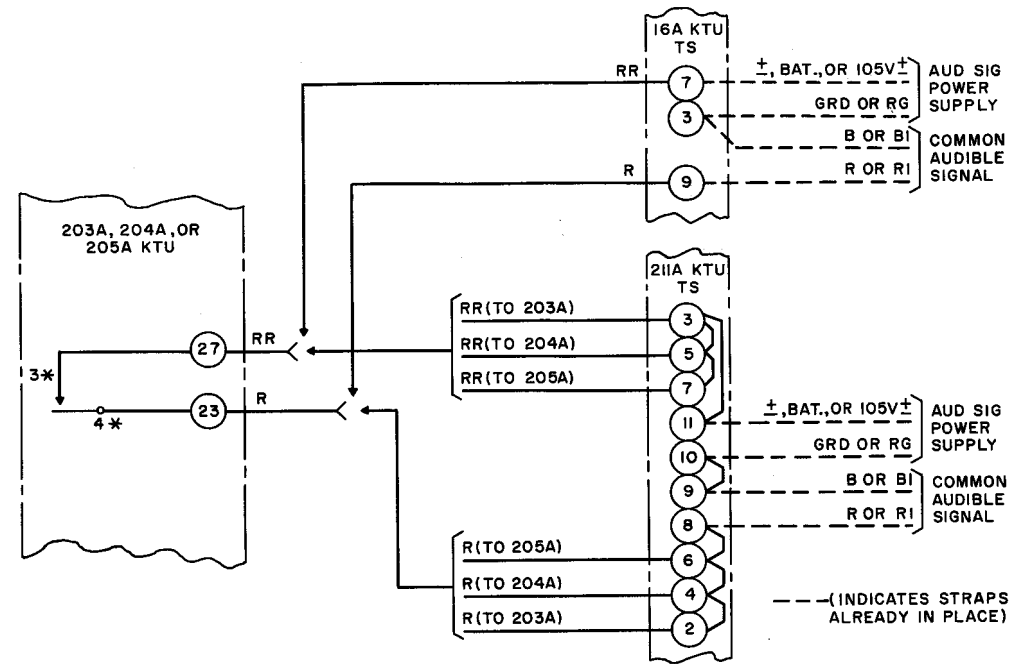

\* 3 & 4B contacts of L1 relay on 203A or 205A KTU or 3 & 4T contacts of R relay on 204A KTU.

Fig. 4 - Typical Connections for Operating a Common Audible Signal Controlled by a 16A or 211A KTU (This Circuit Provides a Steady Audible Signal.)

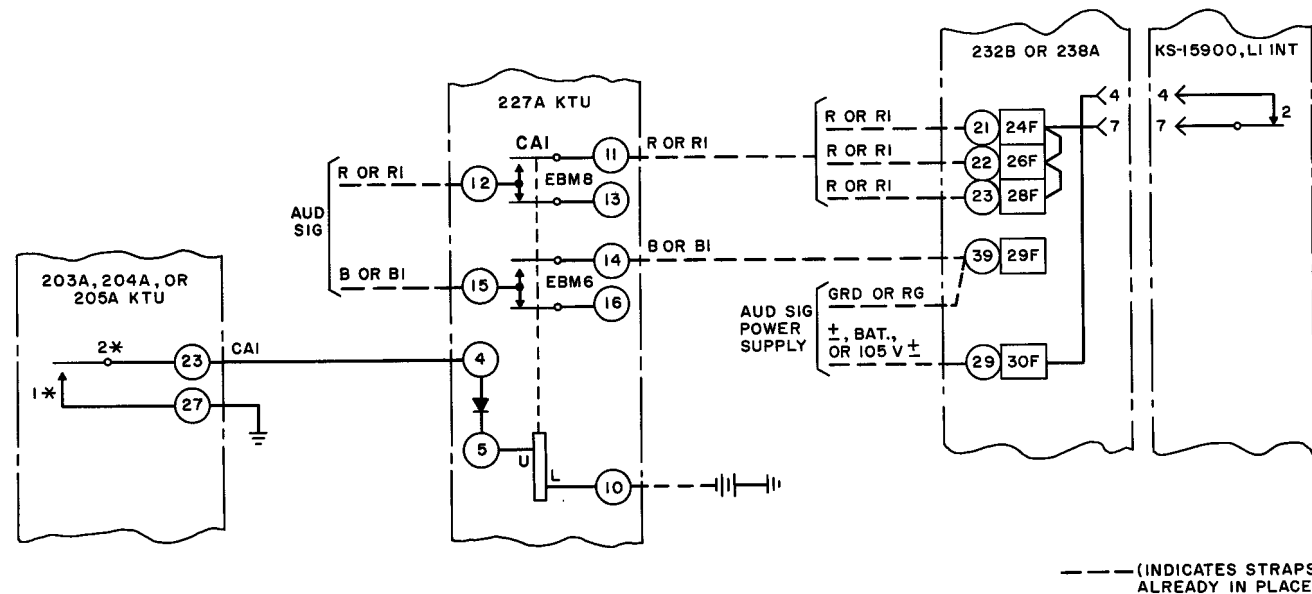

\* 1 & 2T contacts of L1 relay on 203A or 205A KTU or 1 & 2T contacts of R1 relay on 204A KTU.

Fig. 5 - Typical Connections for Operating a Common Audible Signal Controlled by a 227A and 232B or 238A KTU (This Circuit Provides an Interrupted Audible Signal.)

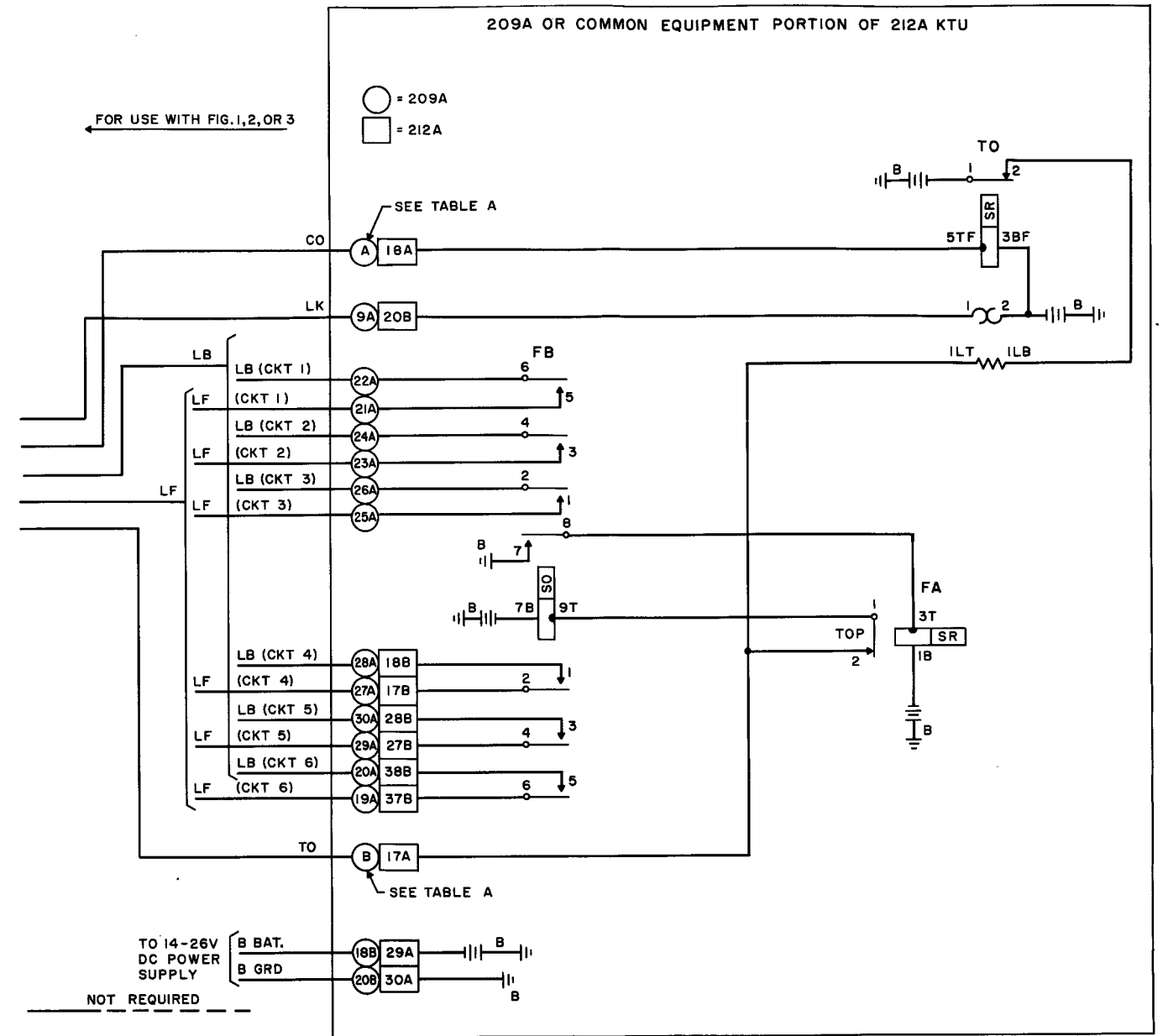

TABLE A

Ref Desig	Lead Desig	Term. on 209A		
		When Conn to 203A	When Conn to 204A	When Conn to 205A
A	CO	6A	7A	11A
B	TO	5A	8A	10A

Fig. 6 - Common Equipment 209A or 212A KTU



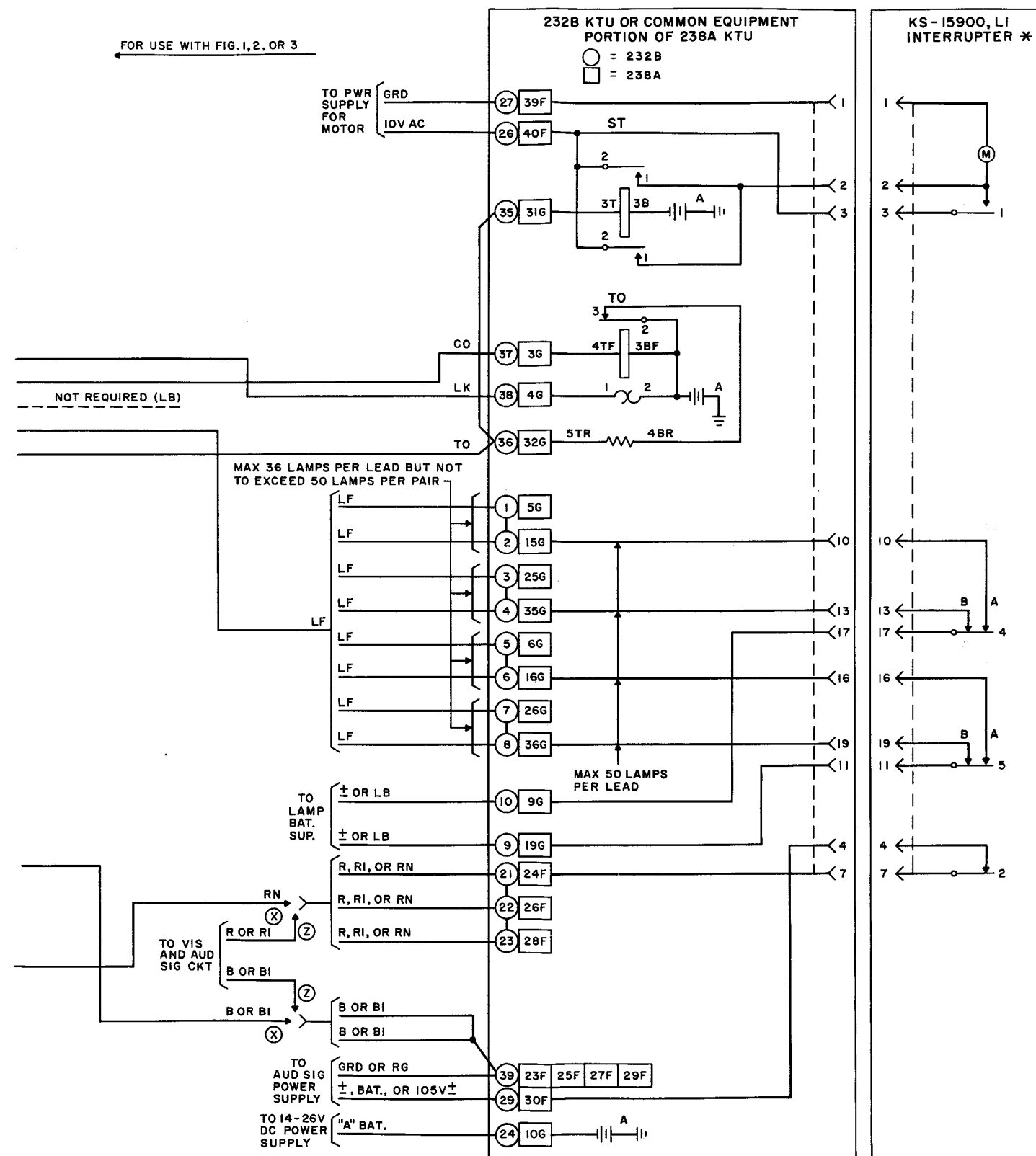
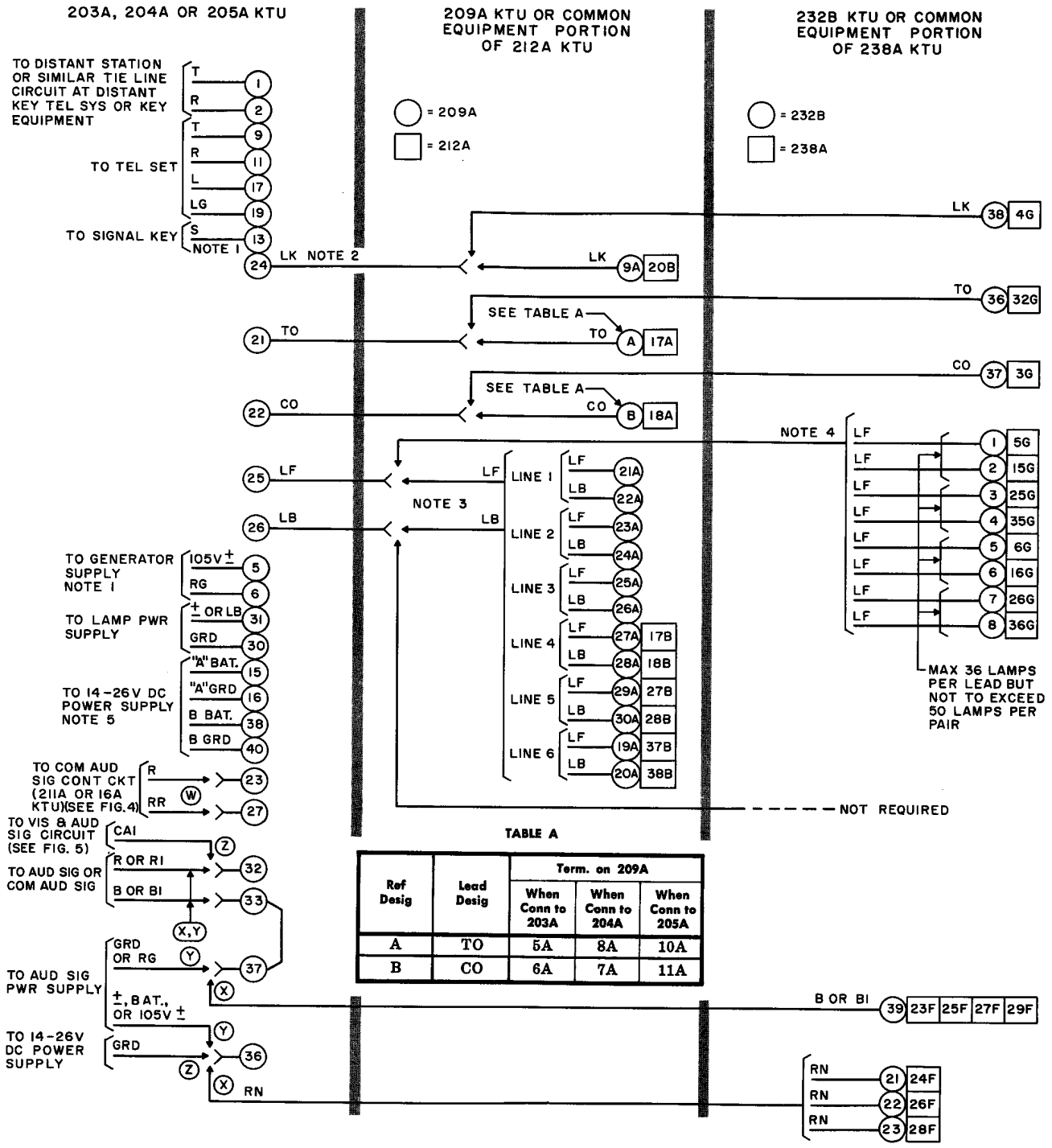

Fig. 7 - Common Equipment 232B or 238A KTU

SECTION C71.349.2



Note 1: Provide only when using 204A or 205A KTU.

Note 2: Provide only when using 204A KTU.

Note 3: Connect LF and LB leads to a vacant line number on 209A or 212A KTU.

Note 4: Connect LF lead to any terminal, provided stated limitation is not exceeded.

Note 5: When using a 101G power plant, A and B battery and ground shall be from the 20-volt dc "Talk" terminals.

OPTIONS:

Ⓢ Steady common audible signal using common audible signal control circuit (211A or 16A KTU).

ⓧ Interrupted audible signal or common audible signal using electromechanical interrupter (232B or 238A KTU).

Ⓢ Steady audible signal or common audible signal.

ⓧ Interrupted common audible signal using relay control circuit (227A and 232B or 238A KTU).

Fig. 8 - 203A, 204A, or 205A KTU Connections to Common Equipment (209A, 212A, 232B, or 238A KTU)