

UNIVERSAL LINE UNIT
KEY TELEPHONE SYSTEMS 1A, 1A1
KEY EQUIPMENTS 100, 101A, 101B, 102A
USING 213B KEY TELEPHONE UNIT

1.00 GENERAL

1.01 This section covers the description and connections required on the 213B key telephone unit.

1.02 The 213B KTU is used to provide a joint line unit for any combination of stations operating on key telephone system 1A or 1A1, and key equipment 100, 101A, 101B, or 102A.

1.03 This unit will furnish an audio and visual signal on incoming calls from a central office or PBX line, pickup, holding, and visual signals when a line is busy or being held.

1.04 The 213B KTU is a panel-mounted unit (see Fig. 1 and 2). It is $4\frac{25}{32}$ inches wide, $6\frac{15}{16}$ inches high, and requires $11\frac{7}{16}$ inch modules on a mounting bar. The relays are designed to operate on 14 to 26 volts dc.

1.05 Common circuits for lamp flashing, time-out, interrupted audible signal, lamp winking, etc, are provided by key telephone system 1A or 1A1.

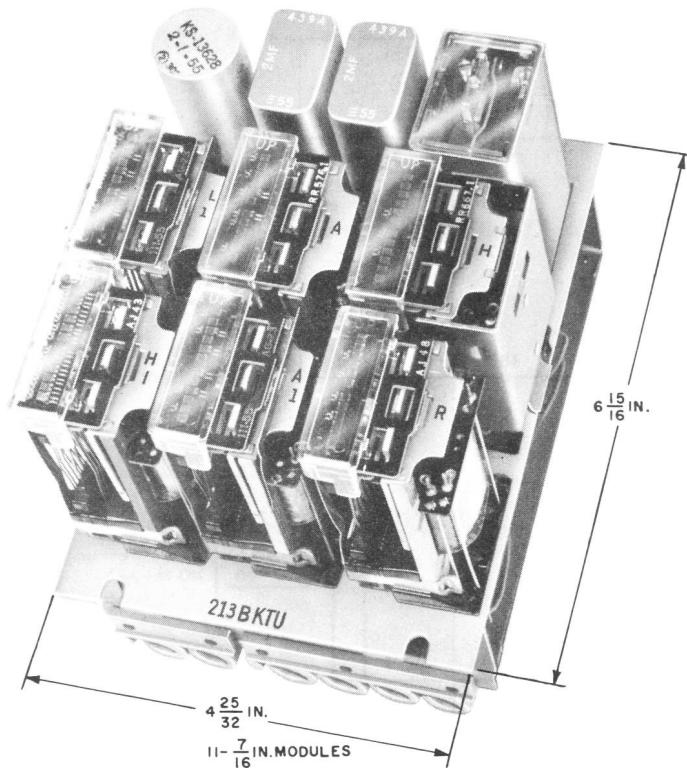

Fig. 1 - 213B KTU, Front View

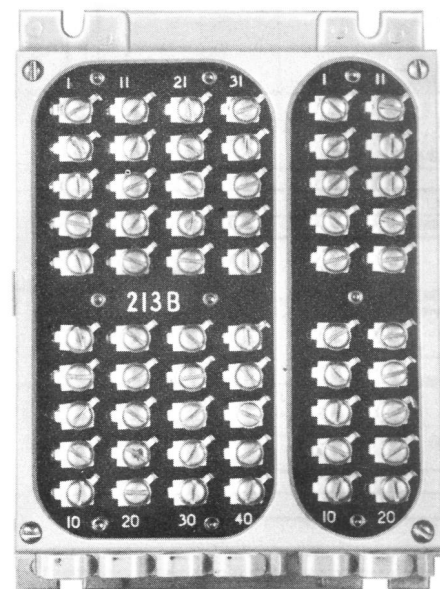

Fig. 2 - 213B KTU, Rear View

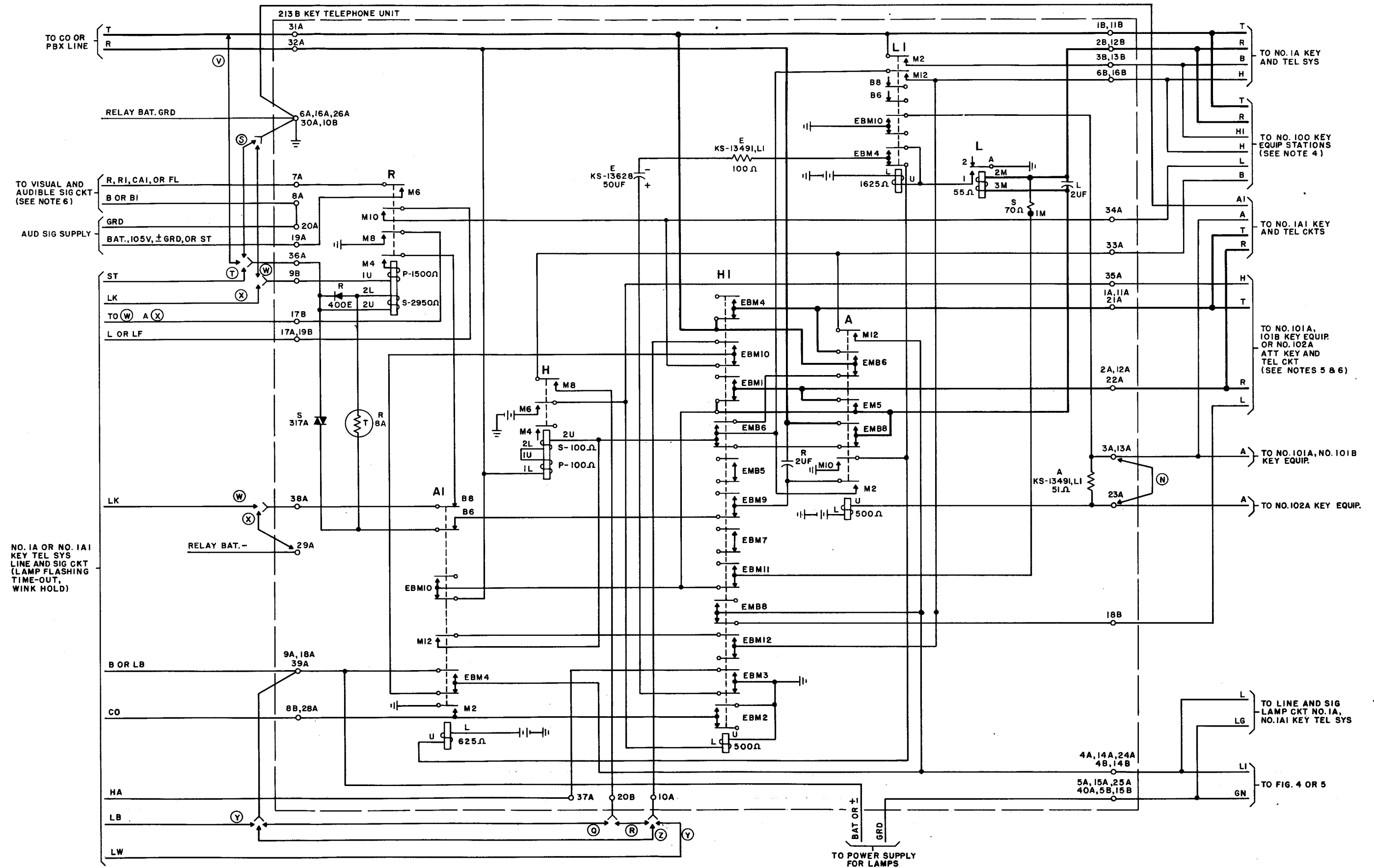

Fig. 3 - 213B KTU Universal Line Circuit

TABLE A

Feature or Option	Provide		
	Fig.	Wire	Quantity
Joint-use Line Ckt	3		1 Per Line
Aux Lamp Power Relay Required (see Note 2)	DC	4	1 Per Line Per Conn Sys
	AC	5	
Hold Lamp Winking Ckt	Not Used		Z
	Used		Y
Common Audible Metallic Ringup Ckt	Continuous Only		V
Common Audible Grounded Ringup Ckt	Continuous		S
	Interrupted		T
Common Circuits Provided by Key Telephone Systems	No. 1A		X
	No. 1A1		W
Key Equipment No. 100, Busy Lamp Signal During Hold	Steady Lamp		Q
	Flashing Lamp		R
Key Equipment 102A Associated with Other Key Telephone Systems	Remove N Wiring		N

Circuit Notes:

Note 1: Power supply for this circuit is provided from the connecting key telephone system power supply.

Note 2: This line circuit is frequently associated with more than one key telephone system or key equipment installation. Under these conditions the lamp power supply of the system with which the line circuit is primarily associated may be used for all the lamps, provided the lamp grounds are common. If the lamp grounds are not common, lamps of the other systems shall be operated from their own power supplies by means of an auxiliary lamp-power relay supplied one-per-line per connecting system as shown in Fig. 4 and 5.

Note 3: If winking signal is not satisfactory, increase the back tension of R1 relay by turning the armature tension screw not more than two turns counterclockwise, or adjust by using a relay test set in accordance with the circuit requirements table.

Note 4: When connecting the line circuit to key equipment 100, disconnect H1 lead from T lead at the key equipment, and then dead-end this H1 lead at the key equipment.

Note 5: When this circuit connects to key equipment 101A, B, or 102A, the line circuit must be connected to the same source of dc power supply for relays as for the key equipment. This is to prevent blowing a fuse when direct battery of different voltages is connected to each end of H lead.

Note 6: For common audible signal at key equipment 101 or 102, connect M6 contacts of R relay to the FL and ST leads of the flashing circuit in key equipment 101 or 102.

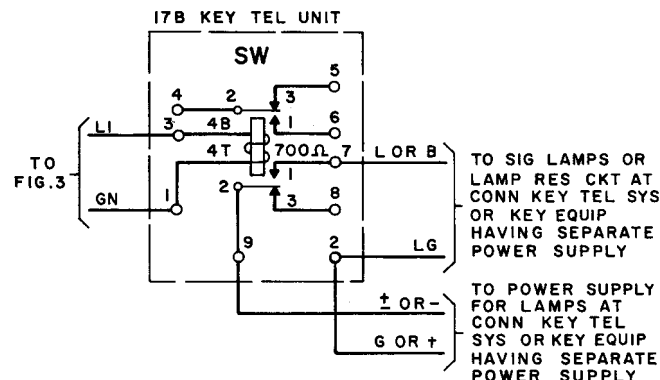

Fig. 4 - DC Switching Lamp Circuit

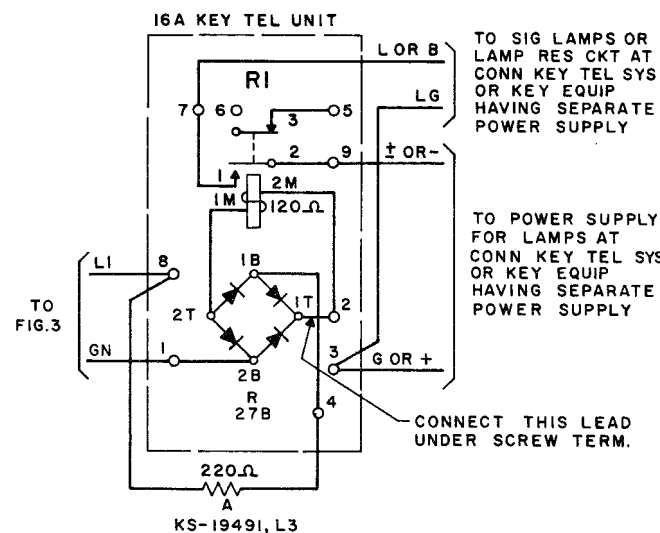

Fig. 5 - AC Switching Lamp Circuit

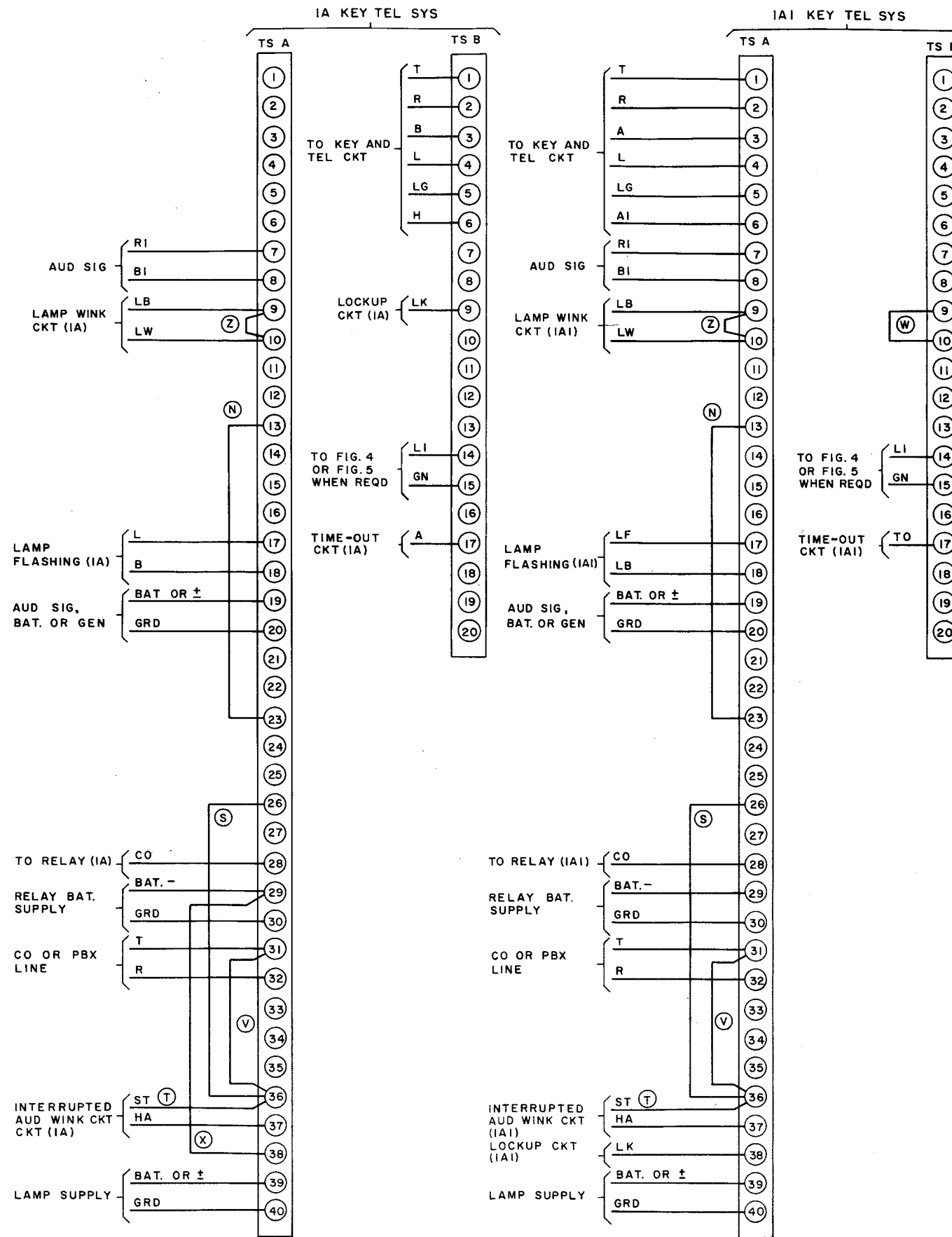

Fig. 6 - 213B KTU Connection Data Used on No. 1A or No. 1A1 Key Telephone System

Reference: SD-69230-01

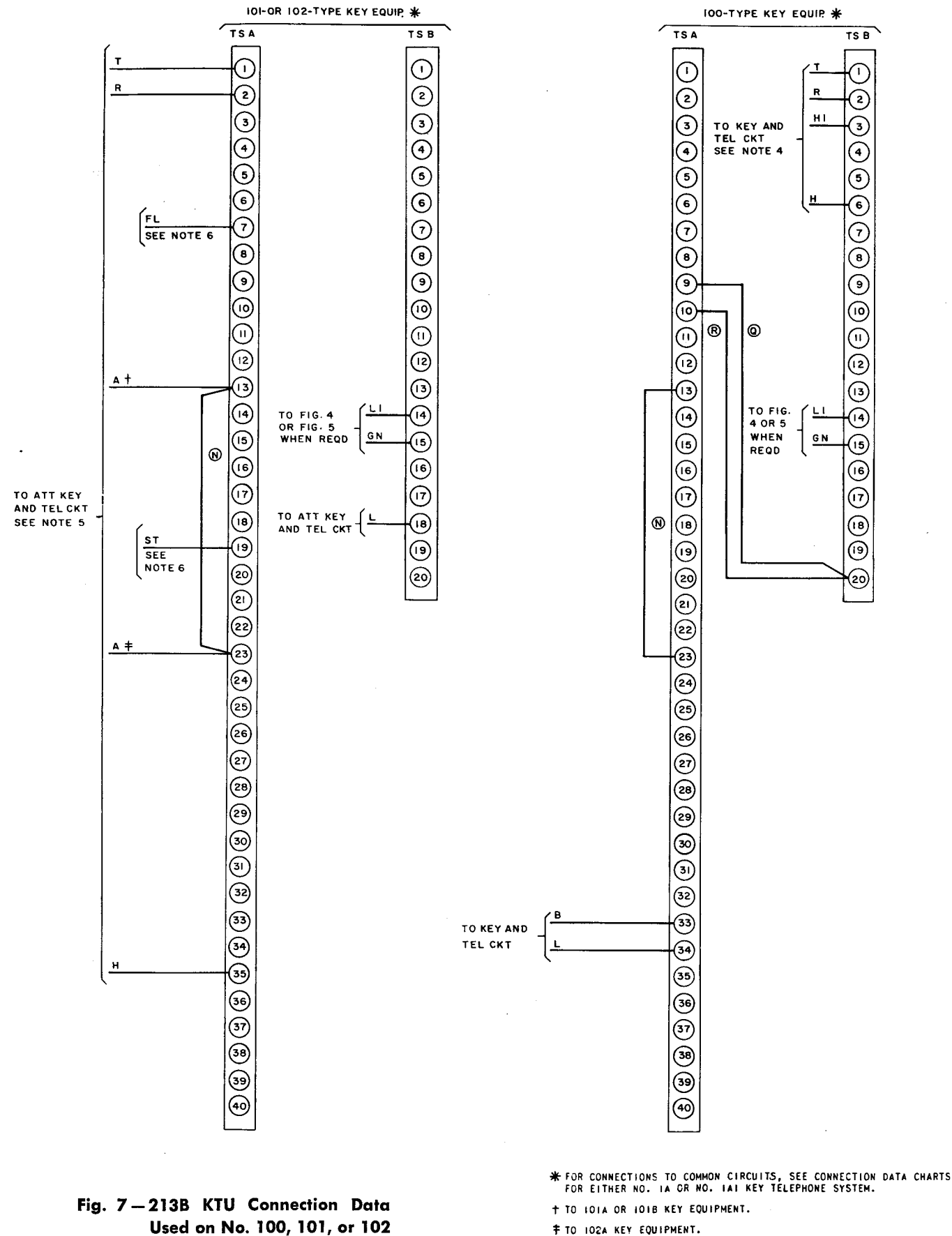

Fig. 7 - 213B KTU Connection Data
Used on No. 100, 101, or 102
Key Equipment.

* FOR CONNECTIONS TO COMMON CIRCUITS, SEE CONNECTION DATA CHARTS FOR EITHER NO. 1A OR NO. 1A1 KEY TELEPHONE SYSTEM.
† TO 101A OR 101B KEY EQUIPMENT.
‡ TO 102A KEY EQUIPMENT.

Reference: SD-69230-01

1.06 The earlier 213A KTU is rated Manufacture Discontinued. It differs from the 213B in that no provision has been made on the 213A for the following:

- Metallic return for ringup circuit.
- Separate line or busy lamps on key equipment 100.
- Parallel operations of key equipment 102A with other key equipment or key telephone systems.

Note: For detailed information on the 213A KTU, refer to SD-69230-012.

2.00 CONNECTIONS

2.01 Fig. 6 and 7 show necessary terminations to be made for incoming lines, power supply, straps within and between key telephone units, and key or running cables to the stations.

2.02 Fig. 3 is a circuit drawing of the 213B KTU with various wiring options. Refer to Table A for the proper option required.

3.00 DESCRIPTION OF OPERATION, CENTRAL OFFICE OR PBX LINE CIRCUIT

Incoming Call

3.01 Signaling: When ringing generator is applied to the line on an incoming call, the first half-cycle of the ac component flows through the R capacitor, R thermistor, secondary winding of R relay, to ground, to ST lead, or to tip side of line, operating the R relay. On the other half-cycle, current flows from ground, ST lead, or tip of line through the R varistor, R thermistor, R capacitor to ring side of line. The R relay locks operated on its primary winding under control

of A1 relay and time-out circuit in the associated key telephone system 1A or 1A1. The operated R relay:

- Connects ground to the TO or A lead, starting time-out and lamp flashing circuit.
- Connects signal lamp leads to flashing circuit.
- Closes circuit for continuous audible signal.

The L capacitor and 70-ohm noninductive secondary winding on L relay are provided to prevent L relay from operating on ringing current when a ringer is bridged across the line at a station operating on key telephone system 1A.

Answering An Incoming Call

3.02 No. 1A1 Key Telephone System or No. 101 or 102A Key Equipment: Ground is placed on A lead from the telephone station, operating A relay, which in turn:

- Applies ground to operate A1 relay and discharge the E capacitor.
- Opens holding circuit.
- Connects tip and ring of line through to telephone station.

The operated A1 relay:

- Removes short circuit from H relay.
- Opens locking path of R relay, releasing it.
- Applies ground to CO lead, disabling time-out circuit.
- Connects lamp battery to signal-lamp lead.

- Opens ringup circuit to prevent crosstalk.

The talking condition is now established.

3.03 No. 1A Key Telephone System or No. 100 Key Equipment: The *L* relay is operated from battery on the ring of the line through EBM-10 contacts of *A1* relay, the station loop, and back to ground on the tip side of the line. The *L* relay operates *L1* relay, which in turn:

- Applies ground to the *A* lead, operating *A* relay.
- Connects *E* capacitor to ground through contacts on *L* relay to discharge capacitor.
- Connects *H* relay to hold lead.
- Connects tip of line to balance lead.

After operation of *A* relay, unit operates in the same manner as described in 3.02.

3.04 Outgoing Call: Procedure for originating an outgoing call from any station is the same as for answering an incoming call, except that *R* relay will already be released. When dialing from key telephone system 1A or key equipment 100, *L* relay may follow dial pulses. The *L1* relay is slow to release due to *E* capacitor and *E* resistor which will hold it operated while *L* relay is following dial pulses.

Holding

3.05 No. 1A1 Key Telephone System: Operation of the hold key in the telephone set will open ground on *A* lead and release *A* relay. The *E* capacitor and *E* resistor cause *A1* relay to release slowly. The *H* relay operates on line current through the telephone set, in turn operating *H1* relay which:

- Connects *H* relay across line as a holding bridge through contacts of *A* relay.
- Opens tip and ring leads to station.
- Connects ground to *CO* lead to disable time-out circuit.
- Connects ground to *HA* lead to start lamp winking circuit.
- Connects signal lamps to winking circuit after release of *A1* relay.
- Opens ringup circuit.

The hold condition is now established.

3.06 No. 101 or 102A Key Equipment Attendant Station: The hold condition is established in a manner similar to that in 3.05, except that operation of the hold key in key box connects battery to *H* lead. Battery on *H* lead:

- Operates *H1* relay.
- Operates *SW* relay in auxiliary hold circuit.
- Applies battery to hold lamps.

Operation of *SW* relay opens *A* lead releasing *A* relay. The *H* relay operating on line current:

- Connects battery to *H1* relay, keeping it operated.
- Connects battery to *H* lead, keeping hold lamps lighted and locking up *SW* relay after hold key is released (*SW* relay releases after pickup key is restored).

The holding bridge is now across the line.

3.07 No. 1A Key Telephone System or No. 100 Key Equipment: Operation of the hold key opens *R* lead from the station and substitutes *H* lead. This opens operating path for *L* relay. The released *L* relay opens the circuit to *L1* relay which is slow to release. The *H* relay operates on line current over *H* lead. After *L1* relay releases, the operating path of *H* relay remains closed to *H* lead through contacts of the *A1* and *H1* relays. Release of *L1* relay releases *A* relay which, in turn, releases *A1* relay. The *H* and *H1* relays perform the same function as described in 3.05.

Release of Holding Bridge

3.08 No. 1A1 Key Telephone System or No. 101 or 102A Key Equipment: When the line is seized again, ground will be placed on *A* lead operating *A* relay. Operation of *A* relay will:

- Open holding bridge, causing *H* and *H1* relays to release.
- Connect tip and ring of line through to the station.

This restores circuit to the talking condition.

3.09 No. 1A Key Telephone System or No. 100 Key Equipment: When the line is seized again, *L* relay will operate on line current causing, in turn, *L1* and *A* relays to operate. Operation of *A* relay opens the holding bridge releasing *H* and *H1* relays, thus restoring circuit to the talking condition.

3.10 From Central Office or PBX: A permanent signal, caused by failure to release a hold circuit, can be released from the central office or PBX by opening the line momentarily. The *H* relay will release and restore circuit to normal.

3.11 Disconnection: When a station disconnects on either incoming or outgoing calls, the *A* and *A1* relays release, returning circuit to normal.

3.12 Auxiliary Lamp Relay: When lamp power supply grounds are not common on jointly connected systems, provide Fig. 4 (for dc operation) or Fig. 5 (for ac operation).