

KEY TELEPHONE SYSTEMS
STATION ARRANGEMENT FOR 2- AND 4-WIRE
NO. 5 CROSSBAR CENTRAL OFFICE LINES
CONNECTIONS

1.00 GENERAL

1.01 This section covers the connections required at the apparatus cabinet to provide various arrangements for 4-wire line circuits and transfer circuits. These connections cover the necessary terminations to be made for incoming lines, power supply, key or running cables to the stations, and cross-connection straps within and between the units.

1.02 Service features for 2-wire central office lines such as illuminated station lamps, holding, etc, are provided by the 1A1 key telephone system. These connections are not covered in this section. For descriptive information and connections for 1A1 units, refer to the appropriate C Sections under the 1A1 key telephone system.

1.03 The installation procedure for this equipment is the same as for the 1A1 key telephone system.

2.00 APPARATUS

2.01 For dimensions of each KTU and for features each provides, refer to the related point section covering identification.



Handling of key telephone units sometimes results in damage to wire-spring relays. After mounting, visually inspect all wire-spring relays for:

- Improper position of contact springs
- Broken cards
- Improper position of cards

2.02 Fig. 1 shows a typical wire-spring relay with the card and springs properly positioned. Other parts are shown merely to aid in identification.

3.00 POWER SUPPLY

This equipment is designed to operate from a 20- to 26-volt dc source. A 101G-type power plant may be used to furnish power. A 101G power plant J86731A, List 4 should be provided when 105-volt 20-cycle ringing is required for the audible signals. The power supply from an associated 1A1 key telephone system installation may be used, providing its capacity is adequate. Power supply arrangements and limitations appear in the C Section covering station systems power supply.

4.00 INDEX OF CONNECTION FIGURES

- Table A - Wiring Options
- Table B - Fuse Requirements
- Fig. 2 - Transmission Pad Options
- Fig. 3 - 4-Wire Line Circuit Connections for Nonexcluded Stations
- Fig. 4 - 4-Wire Line Circuit Connections for Excluded Stations
- Fig. 5 - Connections for Line Transfer Circuit
- Fig. 6 - Connections for Line Transfer Circuit and Auxiliary Line Transfer Circuit.

REFERENCES: SD-69414-01 and
SD-69422-01.

Fig. 1 - Typical Wire-Spring Relay, Without Cover

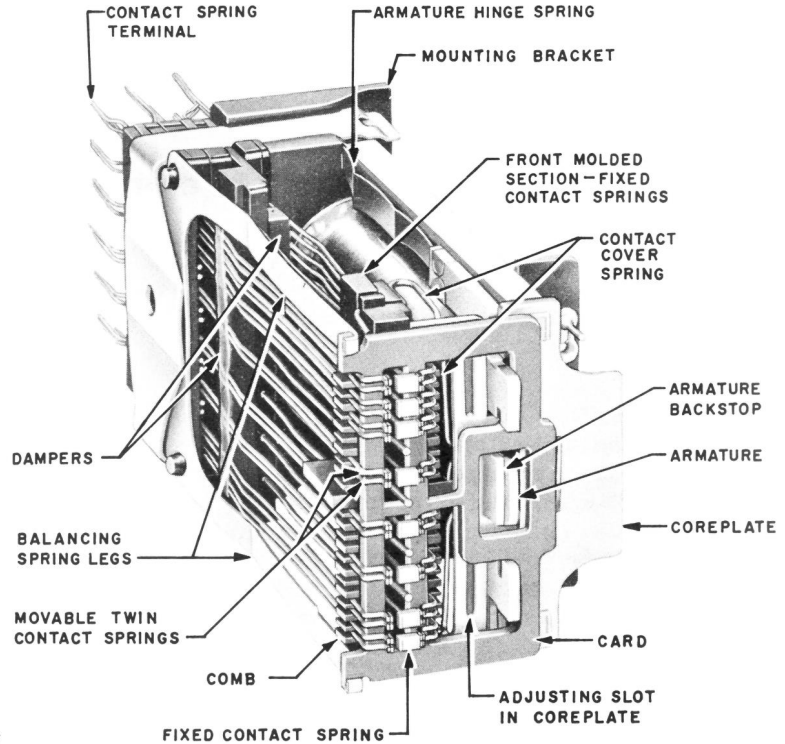

TABLE A

WIRING OPTIONS FOR USE WITH FIG. 3, 5, AND 6

Feature or Option		Wiring	
4-Wire Line Ckt Used with	Encryption or Data Transfer	S	
	Neither Encryption nor Data Transfer	T	
Line Transfer Ckt	Without Aux Transfer	Z	
	Touch-Tone Calling Sets When Special Grade Trunks Are	Reqd*	W
		Not Reqd*	Y, W
	Rotary Dial Sets	X	
	External Conductor Loop Resistance over 200 Ohms	V	
Aux Line Transfer Ckt (Second Data or Encryption Connection) When Special Grade Trunks Are	Reqd		
	Not Reqd	U	
Common Audible Signaling	Steady	R	
	Interrupted	N	
	With Common Aud Control Ckt	Q	

TABLE B

FUSE REQUIREMENTS

Fuse Amp	Potential	One Per
2	-24V Sig	242A or 243A KTU and Assoc Exclusion Control Relay (229B KTU)
2	-24V Sig	All Pickup Relays (229B KTU) Assoc with Same Station
2	-24V Sig	240A KTU and Assoc 241A KTU

* A 227A KTU is required to control audible signals when line transfer is provided on touch-tone calling set.

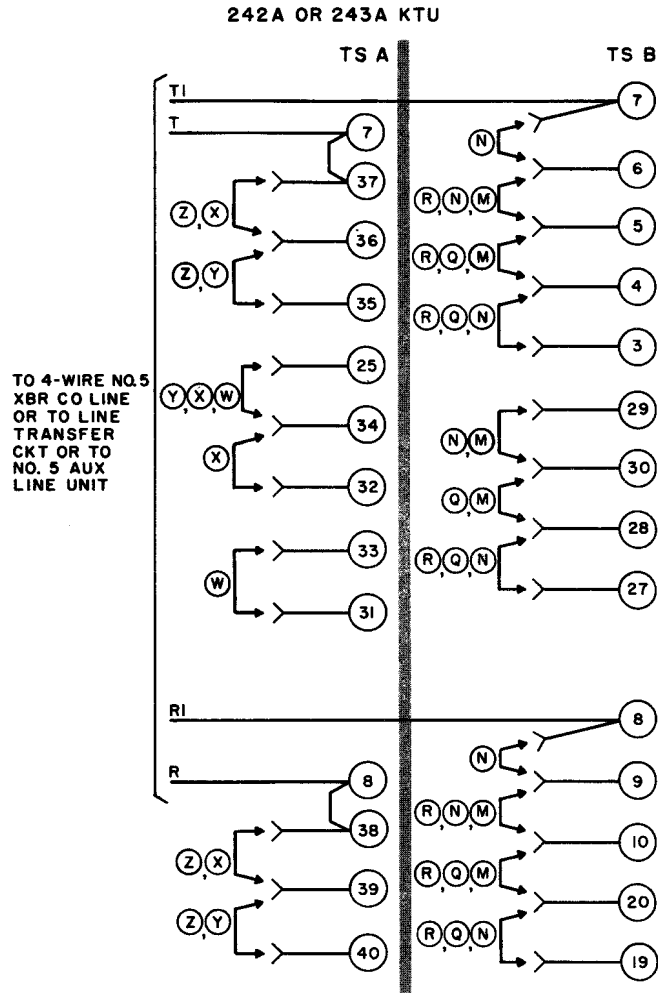

TO PROVIDE TRANSMITTING LOSS OF	PROVIDE OPTION
0 DB	Z
2 DB	Y
4 DB	X
6 DB	W
TO PROVIDE RECEIVING LOSS OF	
4 DB	R
6 DB	Q
8 DB	N
10 DB	M

NOTE: THE OPTIONS SHOWN ARE ADDED TO THE EXTERNAL LOOP LOSS TO OBTAIN THE DESIRED 8db FOR THE TRANSMIT PAIR AND 12db FOR THE RECEIVE PAIR.

Fig. 2 - Transmission Pad Options

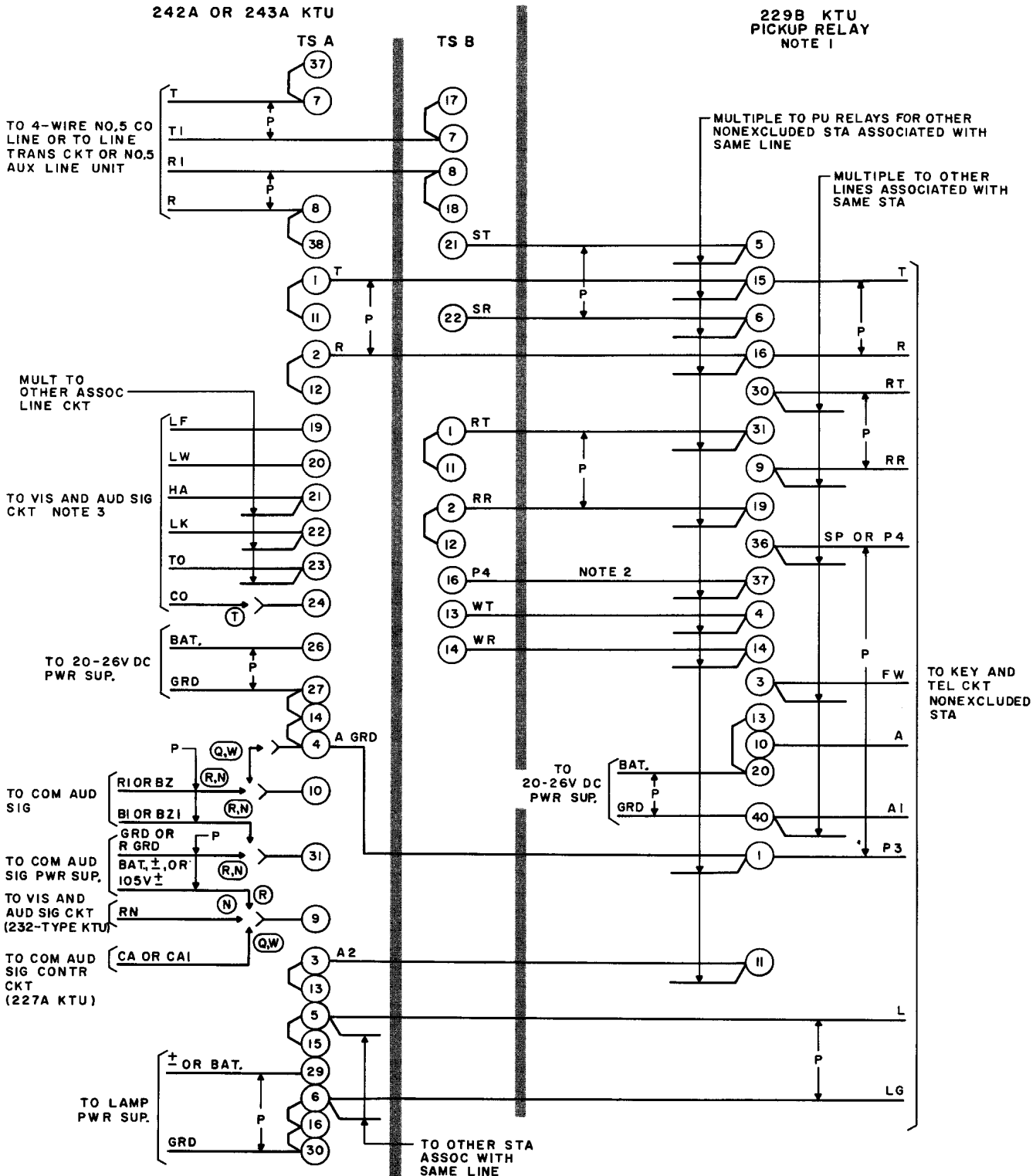

Fig. 3 - 4-Wire Line Circuit Connections for Nonexcluded Stations

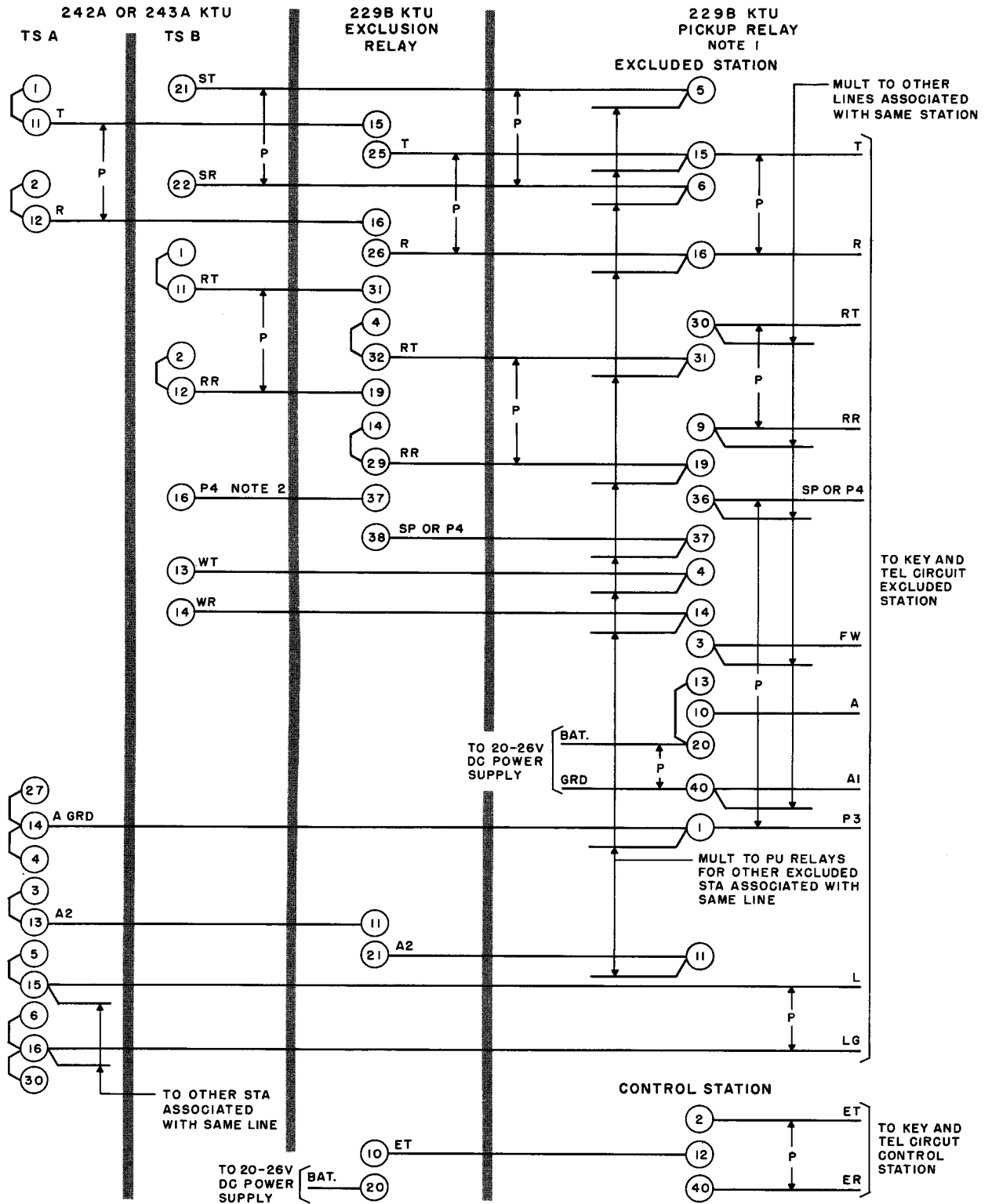

Fig. 4 - 4-Wire Line Circuit Connections for Excluded Stations
(Connections Shown Are in Addition to Fig. 3)

SECTION C71. 835. 01

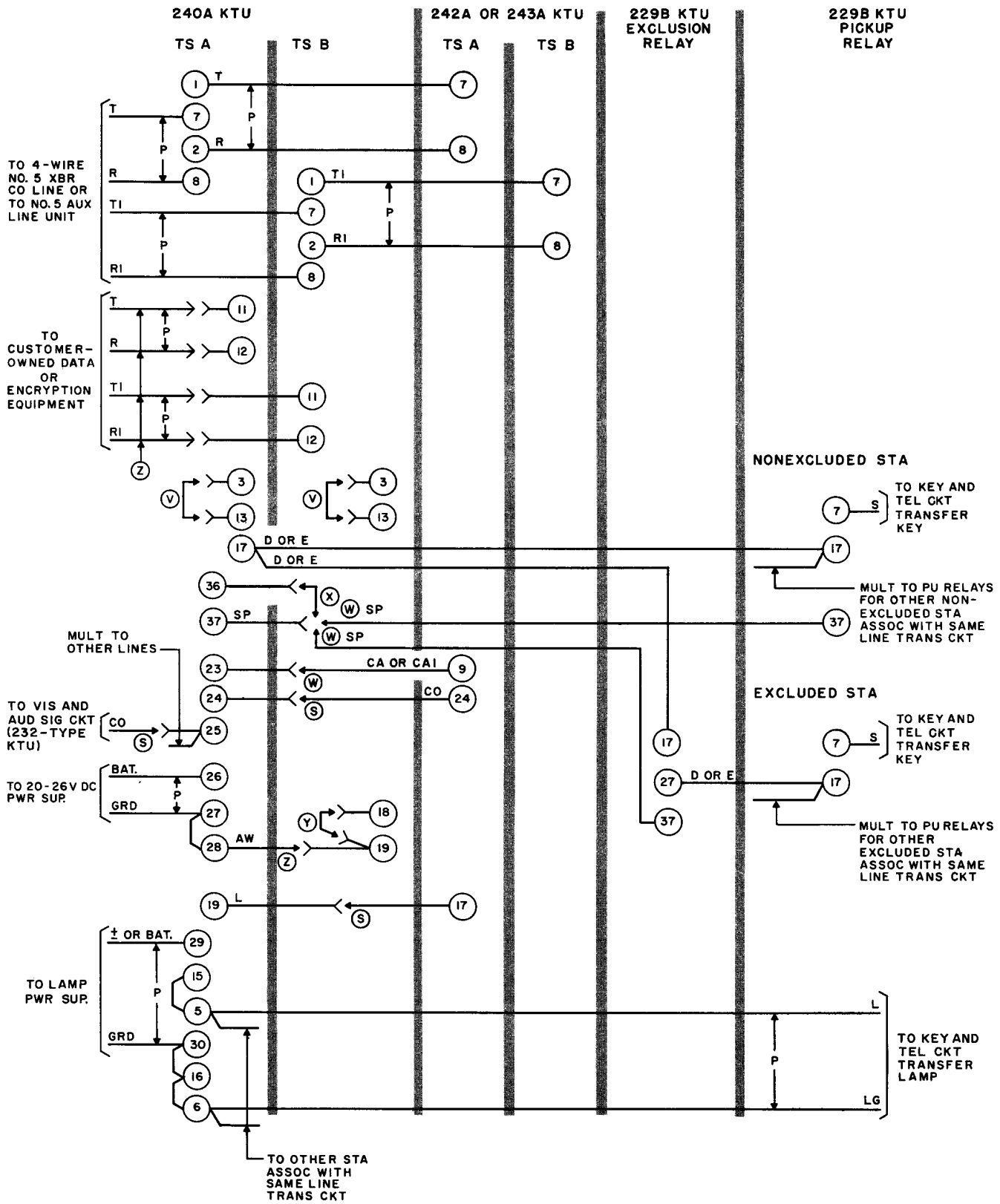

Fig. 5 - Connections for Line Transfer Circuit
(Connections Shown are in Addition to Fig. 3, and to Fig. 4 If Provided)

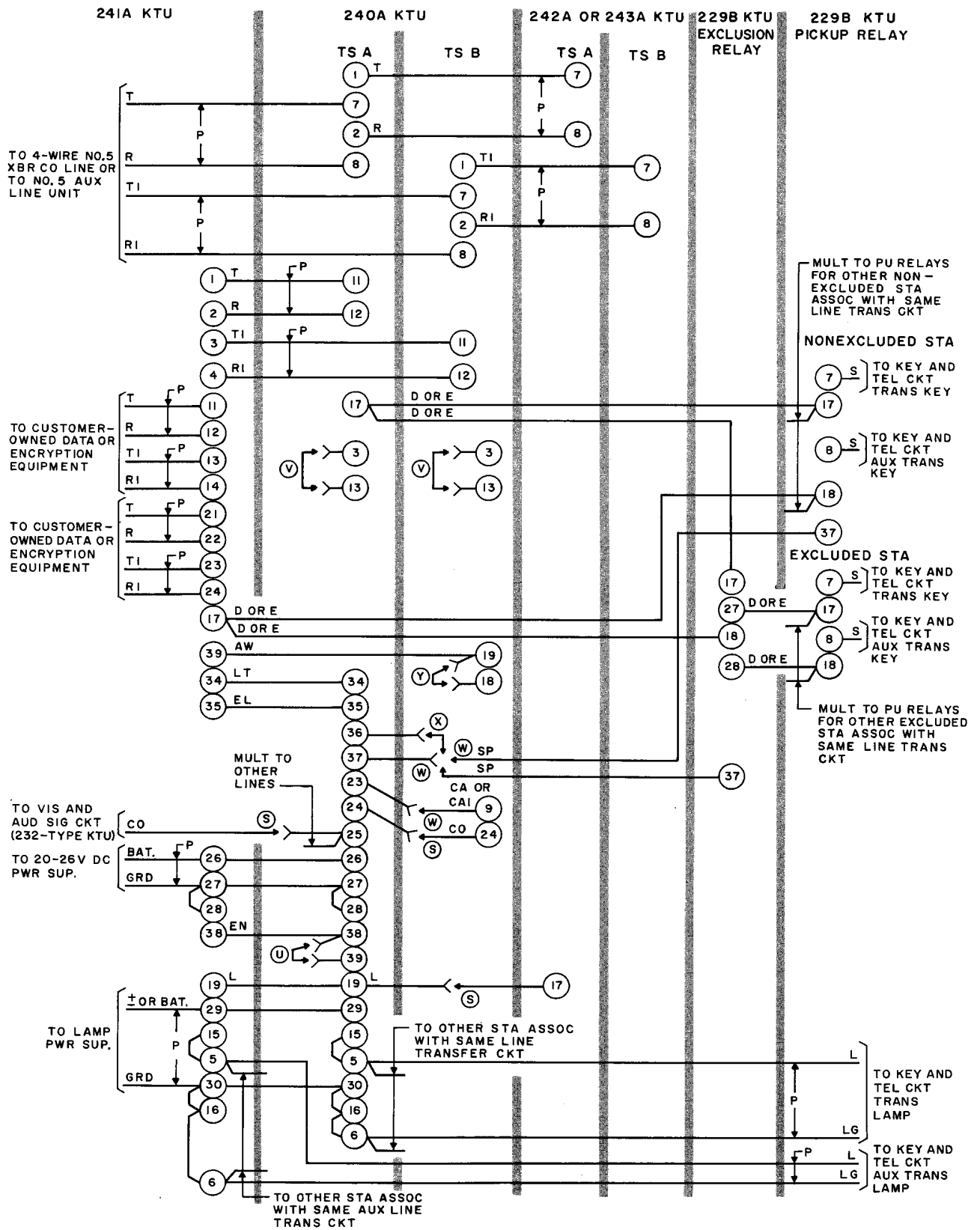

Fig. 6 - Connections for Line Transfer Circuit and Auxiliary Line Transfer Circuit (Connections Shown Are in Addition to Fig. 3, and to Fig. 4 If Provided)